

minn 33
#304

10. 304

FEBRUARY 1963

Town and Country SEWAGE SYSTEMS

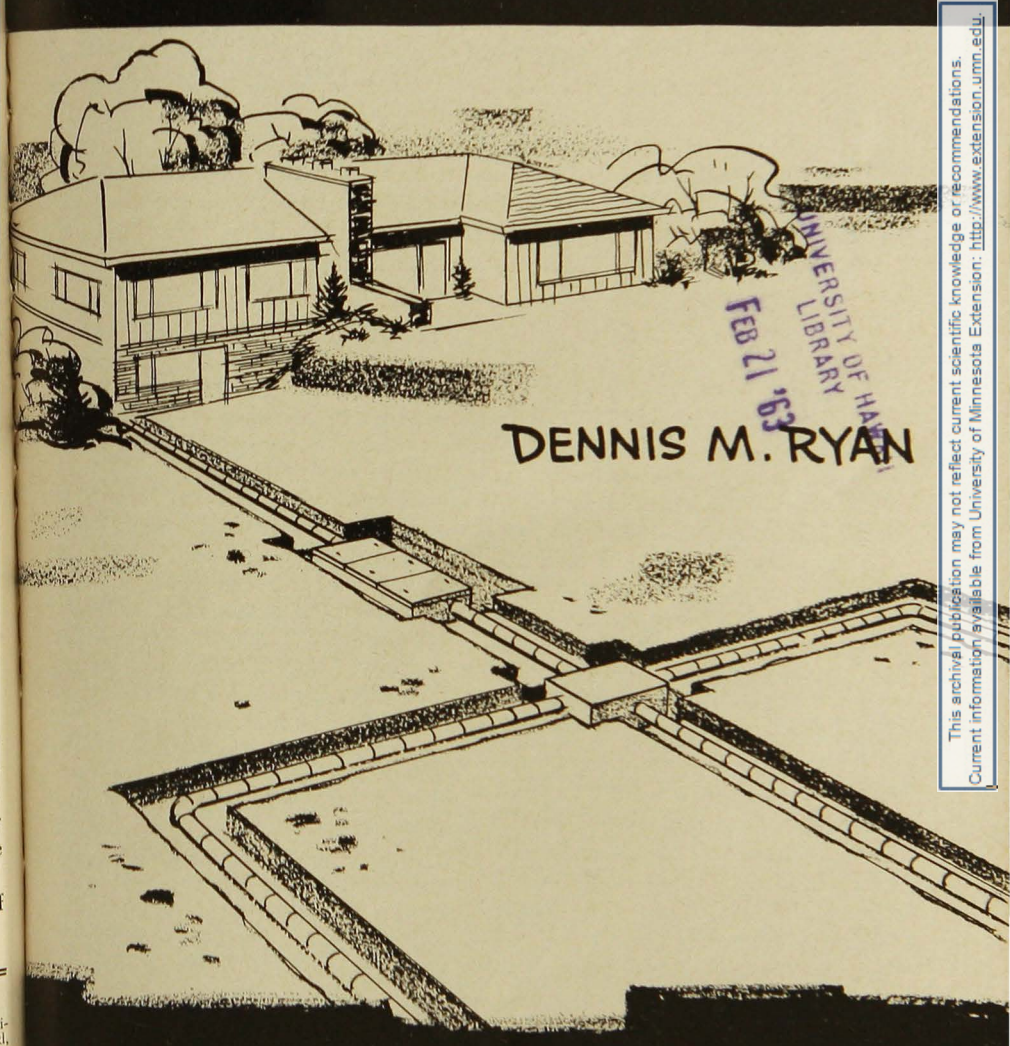

DENNIS M. RYAN

FEB 21 '63
LIBRARY OF HARVARD
UNIVERSITY OF MINNESOTA

This archival publication may not reflect current scientific knowledge or recommendations. Current information available from University of Minnesota Extension: <http://www.extension.umn.edu>

UNIVERSITY OF MINNESOTA
Agricultural Extension Service
U. S. DEPARTMENT OF AGRICULTURE

Town and Country SEWAGE SYSTEMS

Dennis M. Ryan

A SEWAGE DISPOSAL SYSTEM consists of: septic tank, absorption field of standard trenches or a dry well, house sewer, and outlet sewer.

In the septic tank bacterial action breaks down sewage. Standard trenches or a dry well handle final disposal of liquid from the septic tank. The house sewer brings wastes to the tank and the outlet sewer carries sewage liquids (effluent) away to the absorption field.

SIZE OF TANK

The most important part of any sewage disposal system is a large tank. Regardless of family size, a 1,000-gallon tank is the minimum recommended. This capacity handles a garbage disposal unit and an automatic washer. Any added cost from installing an extra size tank is repaid by lower maintenance costs.

A septic tank should hold all inflow long enough to allow bacterial action to liquefy sewage. If bacterial action is complete, nearly clear liquid flows through the outlet. Any adequate disposal system can handle this discharge for years without trouble. But if you use a small "trick-size" tank, sludge and raw sewage may be forced through. Then the disposal field, even in coarse sand, will only work satisfactorily for a short period.

Depth and length are the most important dimensions of your septic tank. These dimensions determine whether or not raw sewage and accumulated sludge are carried out to the disposal field.

Definite minimum dimensions are necessary for successful tank operation, regardless of capacity needed. In a large one-chamber tank, minimum recommended depth is 6 feet. But you can use only about 4 feet to calculate capacity. About 1 foot is lost because the outlet is placed 1 foot below the cover. And subtract another foot to allow for sludge accumulation.

This leaves incoming sewage a distance of 4 feet from the accumulated sludge line. If distance is less, velocity of inflow soon scours sludge on the bottom up into suspension and carries it past the outlet.

The minimum recommended length is 10 feet. This allows suspended

sludge to settle inside the tank instead of flowing out to choke the absorption field.

Let us now analyze the need for a 1,000-gallon tank capacity. A septic tank receives discharge from all plumbing fixtures. It must hold this until bacteria can burn up the raw sewage—for about 72 hours (3 days).

Tank size is based on use of 50 gallons of water per day (24 hours) per person. For a 72-hour period a tank capacity of 150 gallons (50 x 3) per user is needed.

Any tank capacity can be determined, within reasonable limits, if number of people planning to use the tank could be accurately estimated. In analyzing tank failures it was found that many guests during weekends used the tank more than the family

did during the entire week. When estimating number of persons who will use your system, allow for guests, relatives, and hired help.

A safe estimate for minimum numbers would be four for family, one for guests, and one for hired help—a total of six. Therefore, $6 \times 150 = 900$ -gallon tank capacity needed to hold sewage 72 hours. To this you must add the volume necessary for accumulated sludge. When sludge builds up, it reduces capacity. Adding volume for sludge to 900 gives a total of about 1,000 gallons.

Total capacity must be below out-flow elevation because no sewage can be stored above the outlet. Rather than design each tank individually, we recommend a family-size tank (figure 1)—even for only two persons.

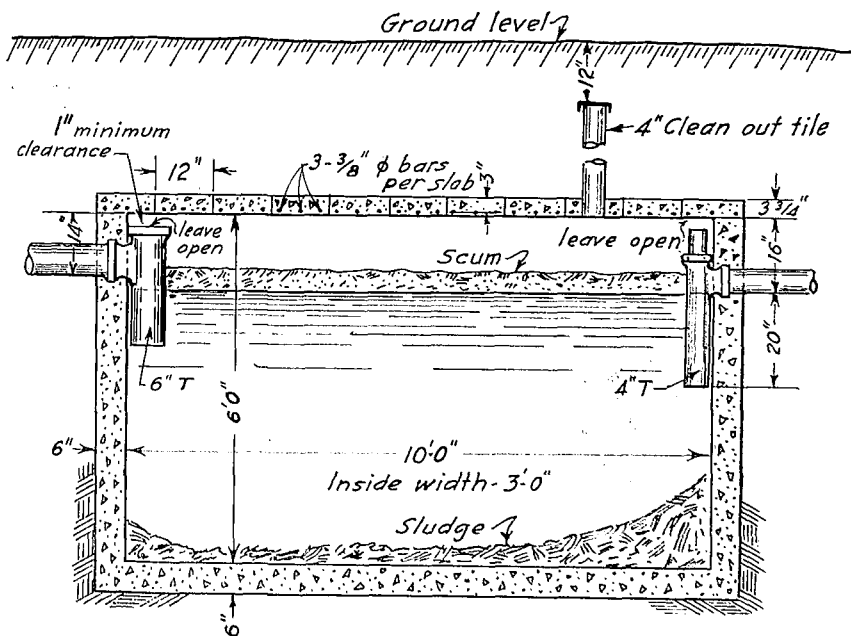

Fig. 1. Cross section of a constructed-in-place septic tank.

LOCATION OF TANK

Location of your septic tank depends upon ground topography. On level ground locate the tank close to the house. This provides necessary minimum grades in both house sewer and outlet sewer. You may place the tank adjacent to the foundation wall but not as part of the wall. If grades can be easily obtained, the tank is normally located about 5 to 10 feet from the house.

On heavy flat land, place about 1 foot of dirt over the tank cover. The basement cannot be drained by gravity in heavy flat land.

You can install a sump pump in a pit in the basement or just outside the basement wall to pump basement wastes into the regular house sewer line.

TYPES OF TANKS

You can construct or assemble various types of tanks. Neither the kind of construction material nor tank shape

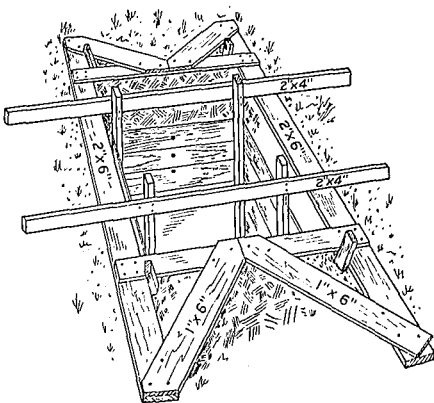

Fig. 2. Inside forms for septic tank braced into position for pouring of concrete.

bears greatly on successful operation of the system. The tank should function properly if it is:

- of adequate size,
- with recommended minimum depth and length,
- made of durable material, and
- provided with necessary absorption field of standard trenches or a dry well.

Constructed-in-Place Tanks

The constructed-in-place tank is best because:

1. The tank is of adequate size.
2. Proper type and placement of inlets and outlets for gas escape are provided.
3. Adequate pumping arrangement for cleaning is part of construction.
4. Through utilization of the owner's labor, the constructed-in-place tank of proper size can be more economical.
5. With a large tank, interval between cleanouts is longer, cutting down maintenance cost.

You may build a constructed-in-place tank of poured concrete, clay tiles, concrete blocks, bricks, or similar materials. Figure 1 illustrates the suggested size: 10 feet long by 6 feet deep by 3 feet wide. Because width does not greatly help to control sludge or raw sewage from scouring through the tank, it is impractical to construct the tank broader than 3 feet. If the tank must be larger, increase length.

More labor probably is used in constructing a poured concrete tank than in other tank installations. So let's examine some necessary building details.

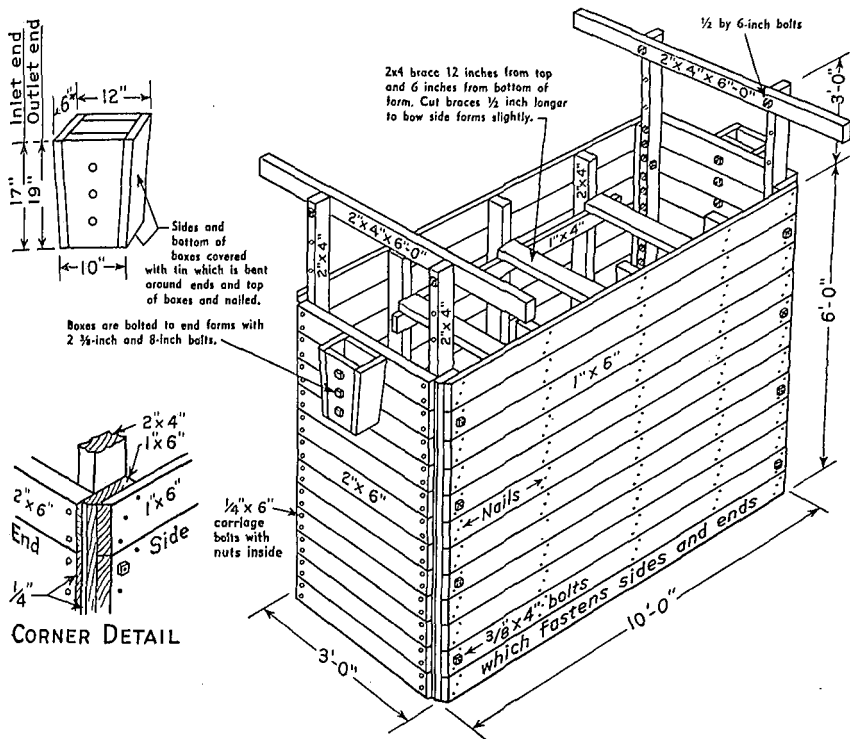

Fig. 3. Typical construction details for reusable septic tank form. Form consists of two end and two side panels fastened at each corner with four $\frac{3}{8}$ -by 4-inch machine bolts. To make side panels nail 1-inch thick boards to 1 by 6's. Bevel ends of side sections, leaving about $\frac{1}{4}$ inch of the 1 by 6 edge. To make end panels bolt 2-inch thick boards to 2 by 4's with $\frac{1}{4}$ -by 6-inch carriage bolts. Set out end panels $\frac{1}{4}$ inch from edge of 1 by 6 to facilitate removal. Before assembling form, cover with heavy grease the surfaces of corner pieces where they come together. Make sides, ends, top, and bottom of end boxes of 1 by 6 boards to the approximate dimensions shown.

After you choose the site for your tank, level it for excavation. Lay out a plank frame (figure 2) to guide your digging and help prevent caving of the earth excavation walls. Earth walls usually serve as outside forms.

To make sure that side walls are kept vertical, use a plumb bob or carpenter's level. Inside dimensions of the plank frame should equal outside dimensions of the tank. For a family-size tank, the form should be 11 feet by 4 feet.

Excavate hole to predetermined tank depth. This depends on whether the tank is placed close to ground surface or low enough to drain from below the basement. In either case, layout is the same.

Construct inside forms (figure 3) according to inside tank dimensions. Use good material bolted together in sections so sections can be used again. Or, you can use pieces of scrap lumber that are nailed together. But these forms have to be torn apart.

For a family-size tank, dimensions should be 10 feet by 3 feet. Suspend inside forms from the plank frame as shown in figure 2. Extend 2 by 4's on end panels about 3 feet above boarded part of panel. For deep installations you can bolt auxiliary 2 by 4 handles, about 6 feet long, to 2 by 4's on the panel.

Bore enough holes in both permanent and auxiliary handles to regulate the depth forms may be suspended. For minimum depth installation, bolt the bottom of supporting crossbars about 1½ feet above boarded part of panel.

For installation to drain the basement, distance between crossbar and panel should be about 6 feet. This depends on how far the basement floor is below the outside ground line.

When the inside form is within 6 inches of the bottom, brace it into position. The form is now within 6 inches of the dirt wall on sides, ends, and bottom. This allows you to pour concrete in one continuous operation. Danger of leaky joints between sides and bottom is thus avoided.

You can place T pipes in the notch at each end of the tank (see figure 4). T's are held in place with mortar placed in the notch around and above the connection between sewer pipes and T's. Leave tops of T's open so the system can vent back through the house sewer pipe and soil stack. Set the inlet T with at least 1 inch clearance between top of socket and underside of cover.

The outlet device and top of the inlet T should be at the same level. So you must set a 7½-inch length of 4-inch sewer pipe into the top of the outlet T socket. The outlet device should penetrate just far enough below the liquid level to provide a bal-

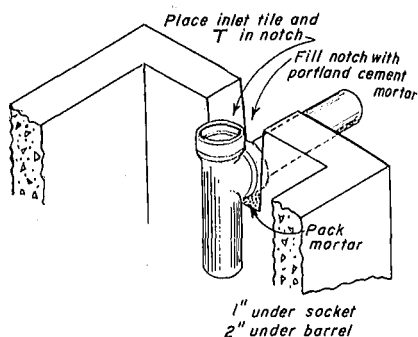

Fig. 4. This shows how inlet and outlet tile are mortared into notch at end of septic tank.

ance between sludge and scum accumulation. Otherwise, you lose part of the capacity advantage.

Material in a septic tank is divided into three distinct layers:

1. Scum at the top.
2. Middle zone free of solids.
3. A bottom layer of sludge.

The outlet device retains scum in the tank. But, at the same time, it limits amount of sludge that can be kept without scouring.

The outlet device should extend below the liquid level to a distance equaling 35 percent of liquid depth. In the septic tank shown in figure 1 this is 20 inches.

You may use baffle plates instead of T's as an alternate construction method. Place the inlet baffle 12 inches from the inlet end of tank. Place the outlet baffle 4 inches from the outlet end. The distance they are placed above and below the liquid line is the same as for T pipes.

Elbows are not recommended on inlets or outlets because the elbow bottoms are below the liquid line. Then gas cannot escape.

To form slot for the baffle, nail a 2-inch by 1-inch piece of lumber outside the inside form in desired place.

A precast cover made of concrete is satisfactory. You may lay out 2 by 4's set on edge in a rectangular pattern on a smooth surface protected by tar paper. Use a 4-foot wide form. Break the length up into as many 1-foot subdivisions as needed.

Reinforce each 1-foot section by placing three pieces of $\frac{3}{8}$ -inch round reinforcing steel near the slab bottom (see figure 5). For convenience in moving slabs, bend and set reinforcing steel in the fresh concrete for handles. Or use metal rings or horseshoes.

If you use washed sand and gravel, a 1:2 $\frac{1}{4}$:3 concrete mix with not more than 5 gallons of water per sack of cement (two-thirds as much water as cement) is suggested for the septic tank. The family-size tank requires the following materials:

26 sacks of cement

2 $\frac{1}{4}$ cubic yards of sand

3 cubic yards of gravel

33 pieces of $\frac{3}{8}$ -inch round reinforcing bars, 4 feet long

Take care to obtain a workable mix. Spade concrete along form faces to help insure dense, watertight concrete.

You may also construct the septic tank with concrete blocks. Make the

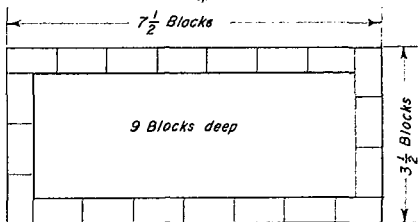
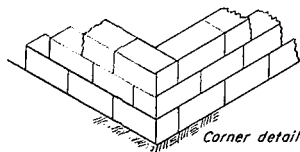

Fig. 6. Layout of concrete block septic tank.

tank 7 $\frac{1}{2}$ blocks long, 3 $\frac{1}{2}$ blocks wide, and 9 blocks deep. Figure 6 shows the method of layout and how to break joints in alternate courses. A concrete floor and precast sectional cover (figure 5) are used in this construction.

Lay heavyweight concrete blocks on a solid foundation and fill mortar joints well. Surface the tank interior with two $\frac{3}{8}$ -inch thick coats of portland cement-sand plaster.

Precast Tanks

This group includes tanks precast either in one piece or in parts to be assembled on the job.

The same family-size capacity of 1,000 gallons applies to these tanks as well as constructed-in-place tanks. If capacity of one tank is not adequate, two tanks can be hooked up in parallel to meet the requirement of a 1,000-gallon capacity.

One piece tanks are usually either reinforced concrete or metal. Reinforced concrete should be properly cured. The metal tank should be coated and should meet the commercial standard of the U. S. Department of Commerce.

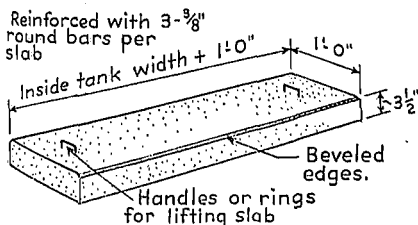

Fig. 5. Concrete cover slab.

Assembled tanks are mostly made of concrete staves or vitrified clay.

HOUSE SEWER AND OUTLET SEWER

The house sewer for the septic tank should be a 6-inch diameter sewer pipe. It must be laid with tightly cemented joints and with bell ends up the slope. A 6-inch diameter for both house sewer and inlet T pipe is recommended because both pipes carry raw sewage. If too small, they may become plugged easily.

If your septic tank is located far from the house, lay a 4-inch house sewer to within one sewer pipe length of the tank. Then expand to a 6-inch sewer pipe and T. Sewage floats better in a 4-inch pipe over long distances. Place the house sewerline with a minimum of 2 percent slope or 1 inch in 4 feet. Lay it without bends to minimize danger of clogging. Allow a 2-inch drop between inlet and outlet of the septic tank (figure 1).

The outlet sewer from the septic tank to the distribution box should be a 4-inch diameter sewer pipe. If the septic tank is working properly, a 4-inch diameter for both the outlet sewer and T pipe is sufficient because nearly clear liquid flows through them.

DISPOSAL OF EFFLUENT FROM SEPTIC TANK

Liquid flowing from the septic tank may be discharged into an absorption field of either standard trenches or a dry well. The first step in design of either system is determining whether soil is suitable for absorption of septic tank effluent and, if so, how much area is required. Soil must have an acceptable percolation rate without

interference from ground water or impervious strata below the absorption system.

The ground water table should be at least 4 feet below the surface. Any impervious strata should be at least 4 feet below the bottom of the trench or dry well.

Percolation Tests

Percolation tests determine rate of infiltration into subsoil. Percolation rates should be figured only on test holes that were filled with water for at least 4 hours. In heavier soils, test holes should be saturated for 24 hours to allow ground to swell. Don't take shortcuts on these tests. Accurate tests give a preview of how the system will work.

The following procedure for percolation tests is similar to the procedure recommended by the Minnesota Department of Health.

1. Number and location of tests. Make two or more tests in separate test holes spaced uniformly over the proposed absorption field site. For a dry well there should be a separate hole for each vertical stratum penetrated. Compile the weighted average of results to obtain a design figure.

2. Type of test hole. Dig or bore a hole with horizontal dimensions of 4 to 12 inches and vertical sides to the depth of the proposed absorption trench or the various strata in a dry well. To save time, labor, and volume of water required per test, bore holes with a 4-inch auger.

3. Preparation of test hole. Carefully scratch bottom and sides of the hole with a knife blade or sharp pointed instrument. This removes smeared soil surfaces and provides a

natural soil interface into which water may percolate. Remove all loose material from the hole. Add 2 inches of coarse sand or fine gravel to protect bottom from scouring.

4. Saturation and swelling of soil.

It is important to distinguish between saturation and swelling. Saturation means that the void spaces between soil particles are full of water. This can be accomplished in a short time.

Swelling is caused by intrusion of water into individual soil particles. This is a slow process, especially in clay-type soil, and is the reason for requiring a prolonged soaking period.

Carefully fill the hole with clear water to a minimum depth of 12 inches over gravel. Keep water in the hole for at least 4 hours, and preferably overnight. Refill, if necessary, or supply a surplus reservoir of water such as an automatic siphon.

Determine percolation rate 24 hours after water was first added to hole. This procedure insures that the soil has ample opportunity to swell and to approach the condition it will be in during the wettest season. Therefore, the test gives comparable results in the same soil, whether made in a dry or wet season.

In sandy soils containing little or no clay, the swelling procedure is not essential. The test then may be made as described under 5C after water from one hole filling completely seeps away.

5. Percolation measurement. With the exception of sandy soils, make percolation-rate measurements on the day following the procedure described under 4.

A. If water remains in hole after the overnight swelling period, adjust depth to approximately 6 inches over gravel. From a fixed reference point,

measure the drop in water level over a 30-minute period. Use this drop to calculate percolation rate.

B. If no water remains in hole after the overnight swelling period, add clear water to bring water depth in hole to approximately 6 inches over gravel. From a fixed reference point, measure the drop in water level at approximately 30-minute intervals for 4 hours. Refill 6 inches over gravel if necessary. Use the drop in the final 30-minute period to calculate percolation rate.

C. In sandy soils (or other soils in which the first 6 inches of water seep away in less than 30 minutes after the overnight swelling period), allow 10 minutes between measurements and run test for 1 hour. Use the drop that occurs during the final 10 minutes to calculate percolation rate.

Absorption Area Requirements

• Any absorption area in square feet should be figured for at least four people.

Table 1. Absorption area requirements

Percolation rate (time required for water to fall 1 inch) in minutes	Required absorption area in square feet per gallon of waste per day
1 or less70
285
3	1.00
4	1.15
5	1.25
10	1.65
15	1.90
30	2.50
45	3.00
60	3.30

- *The absorption area for trenches is figured as trench-bottom area only.*
- *The absorption area for dry wells is figured as effective sidewall area beneath the inlet.*
- *Any percolation rate over 30 is unsuitable for dry wells.*
- *Any percolation rate over 60 is unsuitable for any soil absorption disposal system.*
- *Gallons of waste per day are determined by multiplying the number of users of the system by 50.*

Standard Trenches

A typical layout of a subsurface disposal field is shown in figure 7; cross section and plan view of entire system, A and B; cross section of a tile line, C.

Use sewer pipe between the septic tank and distribution box and beyond the distribution box until lateral lines are at least 7 feet apart. Construct the effective part of the disposal field of drain tile. The 4-inch lateral tile should have a fall of 4 inches per 100 feet. Hold the laterals to 60 feet in length if possible. The more laterals there are the better the system works if one line is not functioning.

In heavier soils it is best to set the system close to ground surface with about 2 feet of cover over tile lines. Soil bacteria that render sewage harmless are present in sufficient numbers only in the upper soil layer. The top layer of heavy soil is well aerated and provides better absorption than deep layers.

When the septic tank sets too high to drain the basement by gravity, wastes can be pumped to the house sewer with an automatic sump pump.

Freezing may be a problem with shallow lines. But freezing rarely occurs in a carefully constructed system kept in continuous operation. It is important that the tile lines are surrounded with gravel. Insulate lines under roads or driveways. A good sod cover over a field is a must.

It is better to risk freezing with shallow lines than to place the system too deep in heavy soil where it may function only a short time. The percolation test points out the difference in disposal field size needed according to field depth in heavy soil.

In lighter soils you can place the disposal field deeper to prevent freezing. Determine field size by the percolation test.

Figure 7C shows a tile laid in a 12- to 36-inch wide trench. Cradle tile in gravel ranging in size from $\frac{1}{2}$ to $1\frac{1}{2}$ inches. Gravel should extend from at least 2 inches above tile top to at least 6 inches below tile bottom.

Cover upper half of joints with building paper. Before backfilling, cover top of gravel with untreated building paper or a 2-inch layer of hay, straw, pine needles, or similar material. This helps prevent gravel from becoming clogged by backfill. Don't use an impervious cover as it interferes with transpiration and evaporation at the surface. Although not figured in calculations, transpiration and evaporation are often important factors in operation of a subsurface disposal field.

The board under the tile is optional. It makes it easier to maintain a uniform slope of 4 inch fall per 100 feet.

To prevent root problems use a liberal amount of gravel under tile. Trenches constructed within 10 feet of large trees or dense shrubbery should have at least 12 inches of gravel under tile.

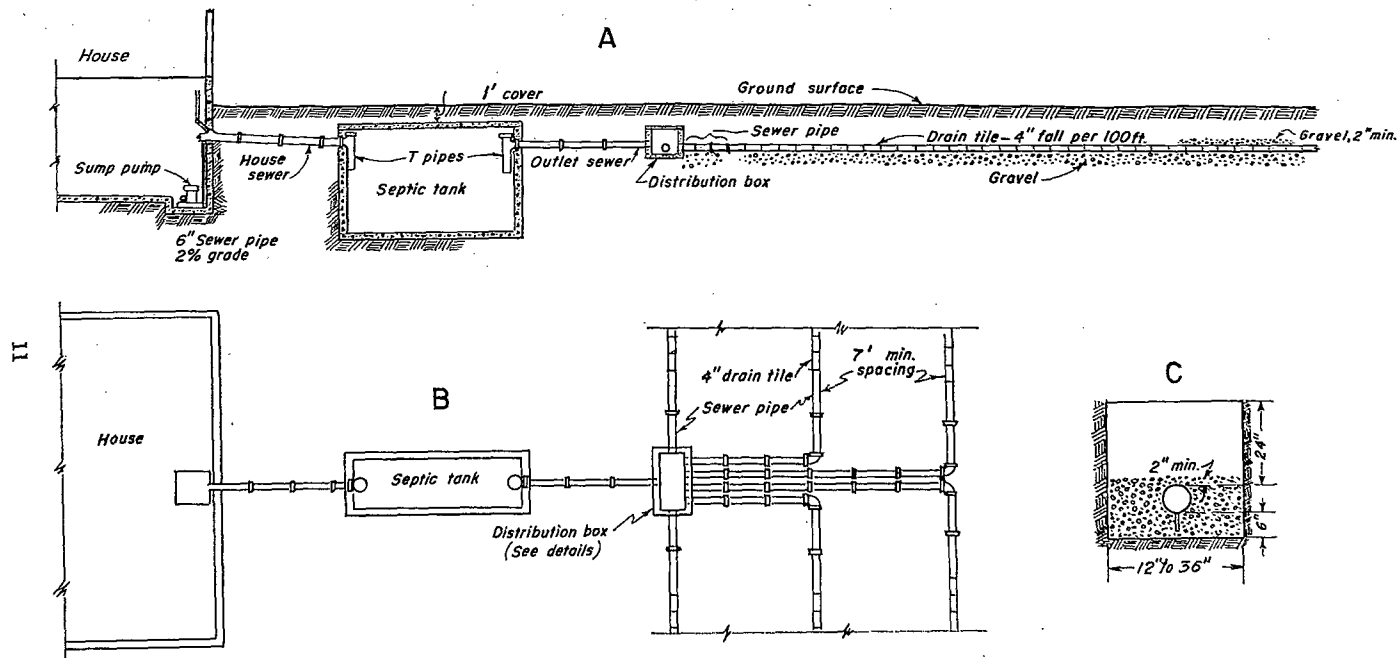

Fig. 7. Standard trench absorption field: cross section and plan view of entire system, A and B; cross section of a tile line, C.

Maintain a safe distance between the site and any water supply source. The distance pollution travels underground depends upon numerous factors, including characteristics of sub-soil formations and quantity of sewage discharged. So it is not practical to specify minimum distances. The greater the distance, the greater the safety provided. In general, all sub-surface absorption systems should be kept 100 feet from any water supply well, 50 feet from any stream or water course, and 10 feet from dwellings or property lines.

Length of trench depends on width of the trench selected. Minimum width is 12 inches and can range up to 36 inches. The required absorption area depends on soil percolation test results (table 1, page 9). For example:

What trench area is needed for six people where percolation rate on proposed site is 1 inch in 10 minutes. In table 1 the required absorption area in square feet per gallon of waste per day is 1.65. The gallons of waste are obtained by multiplying 6 (people) \times 50 = 300 gallons. Then $300 \times 1.65 = 495$ square feet of absorption area.

For trenches 2 feet wide with at least 6 inches of gravel below drain tile, the required total length of trench is $495 \div 2 = 248$ feet. If five laterals are used the length of each lateral is $248 \div 5 = 50$ feet.

Distribution Box

A distribution box (figure 8) is essential for every standard trench system and where more than one dry well is used. The box insures equal distribution of effluent to several tile lines. It is especially useful where topography is not one uniform slope.

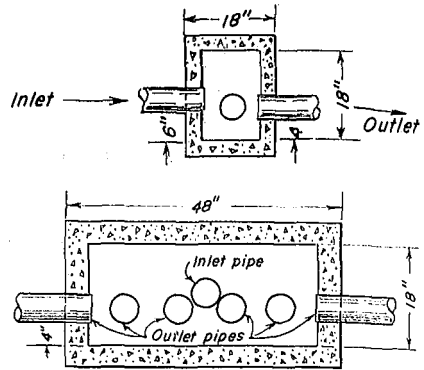

Fig. 8. Top: Distribution box cross section. Bottom: Distribution box elevation.

Two lines might run directly out of the distribution box laterally at a fairly flat grade. Two or more lines, consisting of sealed sewer pipe, could run downhill at a steep grade. Then they would connect to field tile running parallel to the top line at a flat grade.

Outlet tiles should be 4 inches above the floor of the distribution box and all at the same elevation. The inlet tile should be 2 inches higher than the outlet tile.

Make the distribution box large enough to accommodate all tile lines. Width and depth are usually around 18 inches. Length is about 12 inches per outlet tile placed in the long side. A distribution box is a good place to check effluent color and passing of sludge through the system.

Dry Wells

Don't use dry wells where:

- Domestic water supplies are obtained from shallow wells.
- Limestone formations and sink-holes connect to underground chan-

nels where pollution may travel to water sources.

Limit use to locations with coarse sand or fine gravel within 3 or 4 feet of ground surface.

It is important that you compute the capacity of a dry well on the basis of percolation tests made in each vertical stratum penetrated. Compute the weighted average of results to obtain a design figure. When figuring absorption area don't use layers of soil where percolation rate exceeds 30 minutes per inch in the weighted average. The vertical wall area of the dug diameter of pervious soil layers below the inlet is all that can be used. Make no allowance for bottom area.

Place a minimum of 6 inches of gravel or crushed rock around the outside of the dry well. This increases the effective area for absorption and prevents soil or fine sand from washing into the dry well. Use a minimum of 8 inches of gravel in the bottom of any dry well. Many contractors construct the dry well on top of a 2-foot

gravel fill. In either case, gravel acts as a filter to retard sludge from plugging finer grain soils. Depth of excavation should not exceed 50 percent of the depth of any well casing or 20 feet—whichever is least.

Dry wells are usually circular in plan. Vertical walls are usually masonry placed without mortar below the inlet. Lay masonry units above the inlet with mortared joints to provide strength. Concrete block, structural clay tile, hard-burned brick, and field stone are most often used. Don't allow spaces between units. Large openings weaken the wall structure and make it easier for the soil to infiltrate.

Figure 9 shows a dry well 7 feet deep below the inlet. If the dry well is 5 feet in diameter, you add the 6 inch distance the gravel fill occupies on each side to the 5 feet when computing absorption area of the vertical wall. This dry well capacity is for four people and a percolation rate of 1 inch in 1 minute—the fastest allowed.

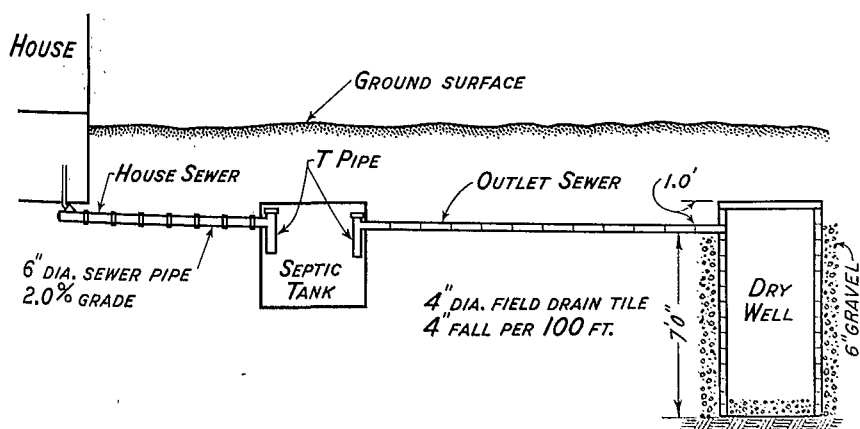

Fig. 9. Layout of sewage system using dry well.

Table 2. Vertical wall areas of round dry wells in square feet

Diameter of dry well in feet	Effective strata depth below inlet in feet										
	1	2	3	4	5	6	7	8	9	10	20
4	12.6	25	38	50	63	75	88	101	113	126	252
5	15.7	31	47	63	79	94	110	126	141	157	314
6	18.8	38	57	75	94	113	132	151	170	188	376
7	22.0	44	66	88	110	132	154	176	198	220	440
8	25.1	50	75	101	126	152	176	201	226	251	502
9	28.3	57	85	113	141	170	198	226	254	283	566
10	31.4	63	94	126	157	188	220	251	283	314	628
11	34.6	69	104	138	173	207	242	276	311	346	692
12	37.7	75	113	151	188	226	264	302	339	377	754

Table 2 illustrates how to figure vertical wall areas of round dry wells. For example:

A dry well of 6-foot dug diameter and 7-foot depth below the inlet has an effective area of 132 square feet. A dry well of the same diameter but 17 feet deep has an area equal to area of a 7-foot depth plus the area of a 10-foot depth which is 132 + 188 or 320 square feet.

Design of Dry Well

Assume that a dry well is to be designed for four people with a home on a lot where the minimum percolation rate is 1 inch in 15 minutes. According to table 1, page 9, an absorption area in square feet per gallon of waste per day is 1.90 for the 15-minute percolation rate. The gallons of waste are 4 (people) \times 50 gallons = 200. The total absorption area in square feet is 200 \times 1.90 = 380.

The following selections meet these requirements:

- One dry well 6 feet in diameter and 20 feet deep.

- Two dry wells 6 feet in diameter and 10 feet deep.

- One dry well 12 feet in diameter and 10 feet deep.

When more than one dry well is used, they should be separated by a distance of three times the largest diameter.

OPERATION AND MAINTENANCE

All wastes from the laundry, bath, and kitchen should run into one large single system. If soapy or greasy water bypasses the septic tank and runs directly into the disposal field, pore space in soil seals quickly.

Waste brines from household water softener units have no effect on a 500 gallon or larger septic tank. Brines may shorten life of a disposal field installed in a structural clay-type soil.

Chemicals, in general, do not improve the functional operation of septic tanks. Some products that are

claimed to clean septic tanks contain sodium hydroxide or potassium hydroxide as the active agent. Such compounds may result in sludge bulking, a large increase in alkalinity, and may interfere with digestion. Resulting effluent may severely damage soil structure and cause accelerated clogging, even if temporary relief occurs immediately after application of the product.

According to the Public Health Service, U. S. Department of Health, Education, and Welfare, some 1,200 products, many containing enzymes, are on the market for use in septic tanks. Extravagant claims were made for some of them. However, none proved advantageous in properly controlled tests.

Ordinary amounts of bleaches, lye or caustics, soaps, and detergents as used in the average household do not greatly harm the system. If septic tanks are large enough, dilution of these materials overcome any harmful effects.

If the dry well becomes clogged, addition of caustic soda or sulphuric acid directly into the dry well gives temporary relief.

The amount to be added is a cut-and-try proposition, according to the amount of sludge doing the clogging. Thus, it is advisable to start with at least 5 gallons of sulphuric acid or 50 pounds of caustic soda. Add more as necessary to relieve plugging.

Cleaning frequency of a septic tank depends on tank capacity and use. Some tanks need cleaning in less than 3 years while others may go 12 to 15 years. Once sludge scours through the

tank outlet it can quickly plug a disposal field to a point where a new field is required.

Although a difficult task, actual inspection of sludge and scum accumulations is the only way to accurately determine when to pump a tank. Make this inspection annually.

Clean tank if:

- Scum layer bottom is within 3 inches of bottom of the outlet device, or
- Sludge top is within 7 inches of bottom of the outlet device.

In the recommended size tank, sludge can accumulate to a depth of 2 feet 6 inches and the scum layer bottom can extend to within 3 feet 4 inches of tank bottom before cleaning is necessary.

To determine scum and sludge accumulations, use a 2 $\frac{3}{4}$ -inch square piece of wood attached to the bottom of a long stick. All septic tanks have three distinct layers of scum, liquid, and sludge. Push the measuring device through the scum layer into the liquid layer. If the stick is carefully moved down and up, resistance on the "foot" should locate the bottom of the scum layer and the top of the sludge layer.

A diagram showing location of tank and disposal field should be made when the system is installed. Other pertinent information such as: length, width, and depth of tank; type and depth of inlet and outlet devices; construction materials; and location of inspection openings should be filed with the diagram.

In this bulletin . . .

- ★ Are additives to a septic tank worthless?
- ★ Why a large tank is a "must."
- ★ Why percolation tests are needed.
- ★ How type of soil affects tank placement.
- ★ Why a dry well is not dependable in heavy soil.
- ★ How a distribution box can solve your layout problems.
- ★ How freezing can be minimized.
- ★ How sulphuric acid or caustic soda can give temporary relief until basic system is changed.



UNIVERSITY OF MINNESOTA, INSTITUTE OF AGRICULTURE, ST. PAUL 1, MINNESOTA

Cooperative extension work in agriculture and home economics, University of Minnesota, Agricultural Extension Service and U.S. Department of Agriculture cooperating, Skuli Rutford, director.
Published in furtherance of Agricultural Extension Acts of May 8 and June 30, 1914.

20M-11-62