

# Pilot-Scale Demonstration of Ilmenite Processing Technology

Submitted by:

Matthew Mlinar, Program Manager, Mineral Processing  
Shashi Rao, Metallurgical Engineer  
Tom Petersen, Technical Manager, Mineral Processing

Date: May 24, 2017

Collaborator:

Process Research Ortech (PRO) Mississauga, Ontario, Canada

Funders:

Iron Range Resources and Rehabilitation Board (IRRRB)  
University of Minnesota Duluth Vice Chancellor for  
Academic Affairs (UMD EVCAA)  
University of Minnesota Office of the Vice President for Research  
(UM OVPR)

NRRI/TR-2017/25

## Natural Resources Research Institute

UNIVERSITY OF MINNESOTA DULUTH

**Driven to Discover**

Duluth Laboratories & Administration  
5013 Miller Trunk Highway  
Duluth, Minnesota 55811

Coleraine Laboratories  
One Gayley Avenue  
P.O. Box 188  
Coleraine, Minnesota 55722

By:   
Matthew Mlinar – UMD NRRI Program Manager, Mineral Processing

By:   
Shashi Rao – UMD NRRI Metallurgical Engineer

By:   
Tom Petersen – UMD NRRI Technical Manager, Mineral Processing

Approved By:   
Richard Kiesel – UMD NRRI Asst. Director Minerals, Metallurgy, and Mining

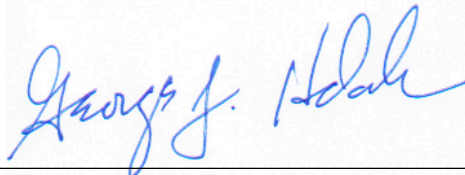
Approved By:   
George Hudak, Ph. D. – UMD NRRI Director Minerals, Metallurgy, and Mining

Peer Reviewed By:

Harvey Thorleifson Ph.D., P.Geo., D.Sc.,  
Director, Minnesota Geological Survey; State Geologist of Minnesota  
Professor, Department of Earth Sciences; College of Science and Engineering  
University of Minnesota

Richard A. Davis, Ph.D.  
Chemical Engineering Department Head  
Professor of Chemical Engineering  
University of Minnesota Duluth

## Executive Summary

The mineral ilmenite is an iron-titanium oxide ( $\text{FeTiO}_3$ ) which is concentrated within small oxide-bearing ultramafic intrusions (OUI) associated with the Duluth Complex in northeastern Minnesota. The historic difficulty in processing titanium resources from the OUI resulted from impurities, such as magnesium oxide, in the crude ore and concentrate products. Previous research found that a large portion of the magnesium is associated with the chemical composition of the ilmenite and cannot be removed using conventional processing techniques. The purpose of this study was to overcome the previous technical constraints by investigating an alternative processing technology. Initial technical success was realized in this study. However, the research presented in this report is not a feasibility study, environmental impact statement, or economic evaluation of this resource.

The primary goal of this project was to prove the technical feasibility of producing high quality iron oxide and titanium dioxide ( $\text{TiO}_2$ ) products from Minnesota ilmenite using beneficiation combined with Canadian Titanium Limited's (CTL) proprietary hydrometallurgical processing technology. The project was conducted in collaboration with partial owner of the CTL technology: Process Research Ortech (PRO). An approximate 100-ton stockpile of ilmenite material obtained from the Longnose OUI and located at the University of Minnesota Duluth Natural Resources Research Institute (NRRI) Coleraine Laboratory was the sample chosen for testing. The NI 43-101 resource for the Longnose deposit includes 58 million tons indicated resource at 16.6%  $\text{TiO}_2$  and 65.3 million tons inferred resource at approximately 16.4%  $\text{TiO}_2$ . The Longnose bulk ilmenite sample was taken from an OUI outcrop at the following coordinates (UTM NAD83) 572,025 East, 5,268,650 North. The ilmenite sample used for testing was found to have the following chemical assay (mass basis): 25.2%  $\text{TiO}_2$ , 28.2% total Fe, 15.4%  $\text{SiO}_2$ , 13.5% MgO, and 0.27%  $\text{V}_2\text{O}_5$ . The majority of the ilmenite sample consisted of ilmenite, magnetite, lizardite, chlorite, and anorthite with lesser parts of talc and hornblende.

Ten metric tons of Longnose ilmenite sample was beneficiated using gravity and magnetic separation to produce an ilmenite concentrate for hydrometallurgical testing. The beneficiation process resulted in three final products: high silica tailings, magnetite/titanomagnetite concentrate, and ilmenite concentrate. The ilmenite concentrate was found to have the following chemical assay: 38.9%  $\text{TiO}_2$ , 31.1% Total Fe, 6.4%  $\text{SiO}_2$ , 7.6% MgO, and 0.32%  $\text{V}_2\text{O}_5$  with an estimated weight recovery of 45.5% and a  $\text{TiO}_2$  recovery of 71.3%. The beneficiation process rejected approximately 74.3% of the total magnesium oxide and 82.1% of the total silicon dioxide. The grinding energy consumption was estimated at 21.1 kWh per ton. The majority of the ilmenite concentrate consisted of ilmenite with gangue constituents of lizardite, chlorite, and hornblende. A mineralogical report showed losses of fine primary ilmenite and secondary ilmenite locked in gangue particles in the gravity separators and some ilmenite losses to the magnetite/titanomagnetite stream. Overall ilmenite recovery to the ilmenite concentrate stream was estimated at 64%.

The CTL process contains five major process steps: atmospheric chloride leaching, oxidation, iron solvent extraction/precipitation/calcination, titanium solvent extraction/precipitation/calcination, and recycle of titanium raffinate back into the leaching stage. A bench-scale hydrometallurgical test program involved determining the CTL magnesium

chloride leaching and solvent extraction system parameters for the ilmenite concentrate. The test program focused on the leach efficiency and extraction efficiency of the target elements; iron and titanium. When re-grinding the ilmenite concentrate to 80% passing 37 microns, a leaching efficiency of 89% for iron and 88% for titanium was achieved. The ilmenite concentrate re-grind was estimated to consume 5.8 kWh per ton; therefore, total grinding energy consumption was estimated at 26.9 kWh per ton. Estimated leaching time was four hours. For the solvent extraction of iron, an organic mixture was determined and isotherms were plotted to determine process staging. Similarly for titanium extraction, an organic mixture was tested to prepare isotherms for pilot plant operation.

Using the data produced during the bench-scale test program, equipment was setup and solutions were prepared to operate a continuous counter-current process for the extraction of iron and titanium. Leaching for the small pilot-scale testing was shown to be less efficient at 81% and 79% for iron and titanium, respectively. Estimated leaching and oxidation time was four hours and 50 hours, respectively. From the leach solution the counter-current solvent extraction of iron and titanium was completed. Extraction and stripping efficiencies of the iron circuit were calculated to be 99.9% and 99.8%, respectively. Extraction and stripping of the titanium circuit were determined to be 99.6% and 99.9%, respectively. The small pilot-scale plant operated for a total of 220 hours.

Using the data obtained from the small pilot-scale testing program, a larger scale pilot plant was commissioned and operated to compile additional data on the performance of the larger scale operation. The large pilot-scale plant was also used to produce a large volume of titanium strip solution to produce  $\text{TiO}_2$  powder for market evaluation. Approximately 2,450 liters of pregnant leach solution was generated at an estimated 83% and 81% leach recovery for iron and titanium, respectively. Estimated leaching and oxidation time was four hours and 50 hours, respectively. During the operation of the iron circuit, extraction and stripping efficiencies of 99.9% and 99.9%, respectively, were achieved while in the titanium extraction circuit extraction and stripping efficiencies of 99.7% and 99.8%, respectively, were achieved. The large pilot-scale plant operated for a total of 133 hours for the iron extraction and 163 hours for titanium extraction processes.

Iron oxide and titanium dioxide powders were produced on batch-basis from the pilot-scale hydrometallurgical strip solutions. A 98.5% pure  $\text{Fe}_2\text{O}_3$  powder was generated via precipitation and calcination. A crystalline rutile  $\text{TiO}_2$  powder was produced via precipitation and calcination at a purity level of 99.3%  $\text{TiO}_2$ . The  $\text{TiO}_2$  powder was benchmarked against a current  $\text{TiO}_2$  powder used in the plastics pigment market. The benchmarking study included chemical purity (via chemical assay), whiteness/brightness (via spectrophotometry), and particle size/morphology (via laser analysis). The NRRI/PRO  $\text{TiO}_2$  products showed lower optical performance than the benchmark product. However, the benchmark material had a surface coating on the product to improve the optical performance whereas the NRRI/PRO product did not. Product optimization is suggested if this product will be used in the pigment industry to improve the optical properties. A purity optimization study found that a titanium product at a purity level of 99.8% was possible by optimizing the titanium solvent extraction and precipitation parameters.

A blended sample of the leach tailings was sent to a third party lab to compare to the Ontario regulation 558 standards for metals and inorganic discharge. The testing results are used to determine what toxic components could potentially be leached from a sample. The solid tailing from the hydrometallurgical process was found to produce lower leachate concentration of metals than the standards of Ontario and was therefore considered an inert waste stream. Although not tested, the following would be envisioned for the remaining streams of the hydrometallurgical process: from the titanium extraction circuit, most of the raffinate is recycled back to the leaching process to recover the magnesium chloride for the CTL mixed chloride leach process. To control the buildup of impurities a bleed stream is removed from the system. Impurities are precipitated using magnesium oxide to produce a mixed hydroxide precipitate. The precipitate is filtered and the precipitate is roasted to form a more stable mixed-oxide solid. The filtrate from the precipitation consists mainly of magnesium chloride as well as very small amounts of calcium chloride, potassium chloride, and sodium chloride. A small pyrohydrolysis unit is expected to be used to hydrolyze the solution and produce magnesium oxide, which could be a potential future product, as well as recycle the hydrochloric acid back into the process. The wash solution generated from the precipitation process contains little in terms of impurities and so treatment would consist of pH adjustment followed by standard industrial water treatment techniques.

A high-level capital and operational expenditure (CAPEX and OPEX) study was conducted by NRRI and PRO as a front-end loading number for future economic estimates. NRRI estimated the CAPEX requirement for the beneficiation plant and PRO, with assistance of a consultant, estimated the CAPEX requirement for the hydrometallurgical plant. PRO, with assistance of a consultant, estimated the OPEX for both the beneficiation and hydrometallurgical process. A design factor of 60,000 tpa  $\text{TiO}_2$  product was chosen as the base case plant size. The high-level cost estimate found that the total CAPEX for a 60,000 tpa  $\text{TiO}_2$  facility was approximately \$164.2M USD to produce a >99% pure  $\text{TiO}_2$  powder product from mining 0.5 Mtpa crude ore. The high-level cost estimate found that the total OPEX for a 60,000 tpa  $\text{TiO}_2$  facility was approximately \$795 per ton of  $\text{TiO}_2$  product. The estimated iron oxide production was estimated at 82,088 tpa  $\text{Fe}_2\text{O}_3$ . The estimated credit for the iron oxide product was approximately \$82 per ton of  $\text{TiO}_2$  product. This by-product credit has an adjusted production cost of \$713 per ton of  $\text{TiO}_2$ . A production cost of under \$1,000 per ton appears favorable compared to other producers in the market, as the average cost of production is estimated at over twice that cost. The beneficiation and hydrometallurgical facility was estimated to require a total of 150 jobs.

A marketing study for the  $\text{TiO}_2$  product was conducted by the University of Minnesota Duluth Center for Economic Development (CED). The focus of this study was to investigate  $\text{TiO}_2$  powder for use in current markets. The  $\text{TiO}_2$  industry was found to contain few producers and a large number of consumers for various end-use applications. The majority of  $\text{TiO}_2$  is used in paints and coatings, plastics, and paper. There are few suitable pigment substitutes to  $\text{TiO}_2$  due to its optical properties. Other uses for  $\text{TiO}_2$  include food, pharma, cosmetics, textiles, electronics, ceramics, and construction materials. Titanium dioxide is also used as a feedstock for further processing, such as titanium metal production. However, additional research is required to determine the technical feasibility of using Minnesota titanium resources for this purpose before determining marketing potential. As this technology progresses and higher

product purities are obtained, further innovations and applications for this titanium material may also arise in the future.

Based upon current understanding of the TiO<sub>2</sub> market and technology presented in this project, below is a list of opportunities for a Minnesota-based TiO<sub>2</sub> production facility:

1. Produce high purity TiO<sub>2</sub> for the paint/coatings industry, but obtain a supply agreement from producers with manufacturing facilities in the area.
2. Produce high purity TiO<sub>2</sub> for the plastics industry, but obtain a supply agreement from producers with manufacturing facilities in the area.
3. Determine what products can use high purity TiO<sub>2</sub> that currently do not (substitute an input). Find a specialty market.
4. Determine what products currently use high purity TiO<sub>2</sub> at small quantities, but are projected to increase demand above current overall market levels as the demand for the niche product increases.

Opportunities for improving the beneficiation and hydrometallurgical processing were discussed. Optimizing of the grind targets could improve the ilmenite recovery in the beneficiation process. In the hydrometallurgical process, opportunities for improvement included decreasing the oxidation time, improving phase disengagement, and improving TiO<sub>2</sub> filtration process through further research. Furthermore, average titanium raffinate showed vanadium, magnesium, chromium, and manganese concentrations of 144 ppm, 64,294 ppm, 49 ppm, and 240 ppm, respectively. Further work is recommended to determine if extraction of these elements is technically and economically feasible. Production of high-value products could also be researched from the iron and titanium strip solution. The high purity TiO<sub>2</sub> powder could be evaluated for use as a feedstock for value-added products like titanium metal or lithium titanate.

It is also recommended that drill core samples be provided to NRRI for testing and/or a drilling campaign be conducted to produce sample quantities for additional bench- and pilot-scale testing. Additional drilling and characterization data would also improve the knowledge of the resource and could promote more development work. Continued research on the by-products from the beneficiation process is recommended to determine the highest value use of these streams. It is recommended that the CTL technology be on-boarded at the NRRI at pilot-scale so the combined beneficiation and hydrometallurgical processes can be coupled and stakeholders have access to observe testing. This demonstration facility could encompass beneficiation, leaching, solvent extraction, and end-product development on a variety of Minnesota ilmenite samples. Following the scale-up testing, it is recommended that a full feasibility analysis be undertaken to establish the commercial requirement for process implementation in Minnesota.

## Table of Contents

Table of Figures .....	ix
Table of Tables .....	xi
Introduction and Background .....	1
Introduction.....	1
Global Titanium Resource Summary.....	2
Production of Titanium Dioxide Technology Summary .....	3
Titanium Production and Pricing in the United States Market.....	5
Ilmenite Resource in Minnesota .....	6
Previous Ilmenite Processing Research at NRRI.....	8
Project Goals, Objectives, and Deliverables.....	10
Materials and Methods.....	10
Testing Sample.....	10
Beneficiation Flowsheet Selection.....	11
Hydrometallurgical Testing Program .....	12
Characterization Methods .....	13
Results.....	14
Sample Preparation .....	14
Sample Characterization .....	14
Chemical Analysis .....	14
Mineralogical and Liberation Analyses .....	14
Beneficiation Testing Summary .....	15
Characterization of Beneficiation Pilot Products.....	17
Bench-Scale Hydrometallurgical Processing Testing.....	20
Chemical Analysis of Leach Feed .....	20
Bench-Scale Leach and Oxidation Testing.....	20
Bench-Scale Iron Solvent Extraction.....	21
Bench-Scale Titanium Solvent Extraction.....	22
Proposed Process Flowsheet for Pilot-Scale Testing.....	23
Pilot-Scale Hydrometallurgical Processing Testing .....	26
Small Pilot-Scale Hydrometallurgical Testing .....	26
Large Pilot-Scale Hydrometallurgical Testing .....	28
Product Development.....	39
Iron Oxide Production.....	39

Titanium Dioxide Production .....	41
Titanium Dioxide Purity Optimization Study.....	47
Composite Product Recovery .....	47
Tailings/Discharge Characterization.....	48
Pilot Plant to Production Scale .....	49
Beneficiation Circuit By-Product Utilization Testing .....	50
NRRI Road Patch Technology Research.....	50
NRRI Nodular Reduced Iron Technology Research .....	52
End-Product and By-Product Markets .....	53
High-Level Capital and Operational Expenditure Estimate .....	54
Titanium Dioxide Product Marketing Study.....	55
Introduction.....	55
Supply and Price .....	55
Demand and Price .....	56
Markets .....	57
Production Opportunities .....	58
Discussion .....	59
Future Testing Recommendations .....	60
Future Considerations .....	61
Conclusions.....	61
Sources.....	64
Peer Review Information .....	66
Intellectual Property Management.....	67
Project Management Summary.....	68
Special Thanks .....	69
Appendices.....	70
Appendix 1: Titanium Processing, Resource, and Producer Review .....	70
Appendix 2: Estimated HPGR-Spiral-LIMS Metallurgical Balance.....	95
Appendix 3: Process Research Ortech Chemical Assay Details .....	96
Appendix 4: XRF and ICP-OES Analyses by AGAT Laboratories on Testing Sample .....	97
Appendix 5: QEMSCAN Analysis by Integrated Process Mineral Solutions (IPMINS).....	99
Appendix 6: Optical Microscopy Analysis by Integrated Process Mineral Solutions (IPMINS) .....	106
Appendix 7: Pilot-Scale Beneficiation Process Metallurgical Balance .....	108
Appendix 8: Summary of Beneficiation Composite Pilot Products Sizing Data.....	109

Appendix 9: XRF and ICP-OES Analyses by AGAT Laboratories on Ilmenite Concentrate 110

Appendix 10: Materials of Construction for Process Research Ortech (PRO) Small Pilot-Scale Plant ..... 111

Appendix 11: Small Pilot-Scale Sample Assays ..... 113

Appendix 12: Materials of Construction for Process Research Ortech (PRO) Large Pilot-Scale Plant ..... 117

Appendix 13: Large Pilot-Scale Sample Assays ..... 118

Appendix 14: XRF and ICP-OES Analyses by AGAT Laboratories on Titanium Dioxide Products..... 126

Appendix 15: XRF and ICP-OES Analyses by AGAT Laboratories on NRRI/PRO Titanium Dioxide Product without Surface Modifiers ..... 127

Appendix 16: High-Level CAPEX Estimate for Beneficiation Plant..... 128

Appendix 17: High-Level CAPEX Estimate for Hydrometallurgical Plant..... 130

Appendix 18: High-Level OPEX Estimate for 60,000 TPA TiO<sub>2</sub> Plant..... 131

Appendix 19: University of Minnesota Duluth Center for Economic Development (CED) Titanium Product Marketing Study ..... 132

## Table of Figures

Figure 1: Generalized Precambrian Geologic Map of Minnesota .....	1
Figure 2: Location of OUIs in Minnesota Duluth Complex .....	2
Figure 3: Typical Feed Requirements for Pigment Plants .....	4
Figure 4: Titanium Industry Feedstock Flow.....	4
Figure 5: Duluth Complex Mineral Deposits.....	7
Figure 6: Longnose Ilmenite Grade Shell Model .....	11
Figure 7: Proposed Hydrometallurgical Flowsheet from PRO.....	13
Figure 8: Actual Bench and Pilot Results vs. Projected Results.....	16
Figure 9: Projected Pilot Results vs. Actual Pilot Results .....	17
Figure 10: Beneficiation Composite Product Sizing .....	18
Figure 11: Bench-Scale Leach Kinetics Test Results .....	21
Figure 12: Iron Extraction Isotherm .....	22
Figure 13: Iron Stripping Isotherm .....	22
Figure 14: Titanium Extraction Isotherm .....	23
Figure 15: Titanium Stripping Isotherm .....	23
Figure 16: Proposed Pilot-Scale Hydrometallurgical Process Flowsheet.....	24
Figure 17: Small Pilot-Scale Iron Circuit Profile .....	27
Figure 18: Large Pilot-Scale Leach Kinetic Data .....	29
Figure 19: Bench- and Pilot-Scale Leaching Comparison.....	30
Figure 20: Large Pilot-Plant Kinetic Data .....	31
Figure 21: Iron Solvent Extraction Process Flowsheet.....	32
Figure 22: Iron Circuit Phase Disengagement .....	33
Figure 23: Iron Solvent Extraction Kinetic Results .....	33
Figure 24: Iron Strip Solution Concentration .....	34
Figure 25: Iron Circuit Full Profile.....	34
Figure 26: Titanium Solvent Extraction Process Flowsheet.....	35
Figure 27: Large Pilot-Scale Titanium Raffinate Quality.....	36
Figure 28: Titanium Extraction Circuit Strip Solution Quality .....	37
Figure 29: Titanium Circuit Phase Disengagement .....	37
Figure 30: Titanium Solvent Extraction Kinetic Results .....	38
Figure 31: Titanium Circuit Full Profile.....	39
Figure 32: Iron Strip Solution Precipitate XRD Pattern .....	40
Figure 33: Calcined Iron Precipitate XRD Pattern .....	40
Figure 34: TiO <sub>2</sub> Precipitation Flowsheet .....	42
Figure 35: TiO <sub>2</sub> Powder Particle Size Distribution.....	44
Figure 36: Pigment Spectral Response .....	45
Figure 37: CIE L* a* b* Chart .....	46
Figure 38: Particle Size Distribution of Potential Road Patch Components .....	51
Figure 39: Potential End-Product and By-Product Market Map .....	53
Figure 40: Supply/Demand Diagram for USA TiO <sub>2</sub> Industry .....	58
Figure 41: Titanium Industry Feedstock Flow.....	71
Figure 42: Schematic flow sheet of the synthetic rutile process.....	72
Figure 43: Global synthetic rutile operations.....	73

Figure 44: Typical chemical composition of titania-rich products from Rio Tinto Fer et Titane (RTFT) at Sorel, Canada.....	74
Figure 45: Indicative quality of Tellnes ilmenite concentrates at TiZir Titanium and Iron in Tyssedal, Norway .....	74
Figure 46: Indicative chemical composition of ilmenite concentrates .....	75
Figure 47: Indicative chemical composition of ilmenite concentrates .....	75
Figure 48: Typical slag chemical compositions are shown in the table below.....	76
Figure 49: Major titanium slag operations.....	76
Figure 50: Titania slag EAF AC smelting process at Rio Tinto Fer et Titane (RTFT) at Sorel, Canada.....	77
Figure 51: Upgraded titania slag process (UGS) at Rio Tinto Fer et Titane (RTFT) at Sorel, Canada.....	78
Figure 52: An overview of the production of Titania slag (AC Smelting), high purity pig iron, rutile and zircon at Rio Tinto’s Richards Bay Minerals in South Africa.....	79
Figure 53: An overview of the production of Titania slag (DC Smelting), high purity pig iron, rutile and zircon Tronox’s Namakwa Sands in South Africa .....	80
Figure 54: Process flow diagram for Bureau of Mines ilmenite conversion scheme .....	82
Figure 55: Typical feed requirements for pigment plants.....	83
Figure 56: Comparison of sulfate processes with chloride processes.....	85
Figure 57: Summary of processes for upgrading ilmenite to synthetic rutile.....	86
Figure 58: Some of the major titanium feedstock producers .....	88
Figure 59: Suitability of titanium raw materials as a function of their TiO <sub>2</sub> content .....	89
Figure 60: U.S. Imports for Consumption of Titanium Concentrates, by Country .....	90
Figure 61: U.S Producers of Titanium Dioxide Pigment in 2014 .....	91

## Table of Tables

Table 1: Average Production, Imports, Exports, and Price Data, 2012-2016 .....	5
Table 2: Product Price Comparison” .....	6
Table 3: Minnesota Ilmenite Drill Core Chemical Analysis and Resource Summary .....	8
Table 4: Chemical Analyses at NRRI and AGAT .....	14
Table 5: Mineralogy of Longnose Ilmenite Head Sample.....	15
Table 6: Specific Gravity of Pilot Products .....	18
Table 7: Estimated Mineralogical Balance on Beneficiation Pilot Products .....	19
Table 8: Ilmenite and Magnetite Balance on Pilot-Scale Products.....	19
Table 9: Chemical Analyses at NRRI and AGAT .....	20
Table 10: Small Pilot-Scale Plant Leach Efficiencies .....	26
Table 11: Initial Small Pilot-Scale Iron Circuit Stage Configuration.....	26
Table 12: Initial Small Pilot-Scale Iron Circuit Operating Conditions.....	27
Table 13: Final Iron Circuit Operating Conditions.....	27
Table 14: Initial Small Pilot-Scale Titanium Circuit Stage Configuration.....	28
Table 15: Initial Titanium Circuit Operating Conditions .....	28
Table 16: Final Titanium Circuit Operating Conditions.....	28
Table 17: Large Pilot-Scale Leach Efficiencies.....	29
Table 18: Average Titanium Feed and Raffinate Concentrations .....	36
Table 19: Fe <sub>2</sub> O <sub>3</sub> Powder Purity.....	41
Table 20: TiO <sub>2</sub> Product Purity Comparison.....	43
Table 21: TiO <sub>2</sub> Product Standards .....	43
Table 22: TiO <sub>2</sub> Powder Particle Size Analysis .....	44
Table 23: CIE L* a* b* Measurements .....	45
Table 24: TiO <sub>2</sub> Product Purity Comparison with and without Surface Modifiers.....	47
Table 25: Unit Iron Throughput.....	48
Table 26: Unit Titanium Throughput.....	48
Table 27: Leach Tailings Chemical Analysis .....	48
Table 28: Leach Tailings Environment Testing.....	49
Table 29: Raffinate Recycle Leach.....	50
Table 30: Estimated Plant Tonnage Rates and Iron Product Recovery .....	54
Table 31: Estimated Plant Tonnage Rates and Titanium Product Recovery .....	54
Table 32: Mixer Settler Design.....	111
Table 33: Large Pilot-Scale Plant Mixer Settler Design.....	117

## Introduction and Background

### Introduction

Northeastern Minnesota possesses vast quantities of mineral resources ranging from iron ore in the Paleoproterozoic<sup>1</sup> Mesabi Range to non-ferrous metals (Cu-Ni-Co-PGE and TiO<sub>2</sub>) in the Mesoproterozoic<sup>2</sup> Duluth Complex (DC). While further characterization of the Cu-Ni-Co-PGE ore deposits has driven much of the exploration activity in the DC in recent years, the DC also has favorable geology for hosting valuable deposits of other metals, such as titanium in the mineral ilmenite. Figure 1, below, displays the generalized Precambrian geologic map of Minnesota.

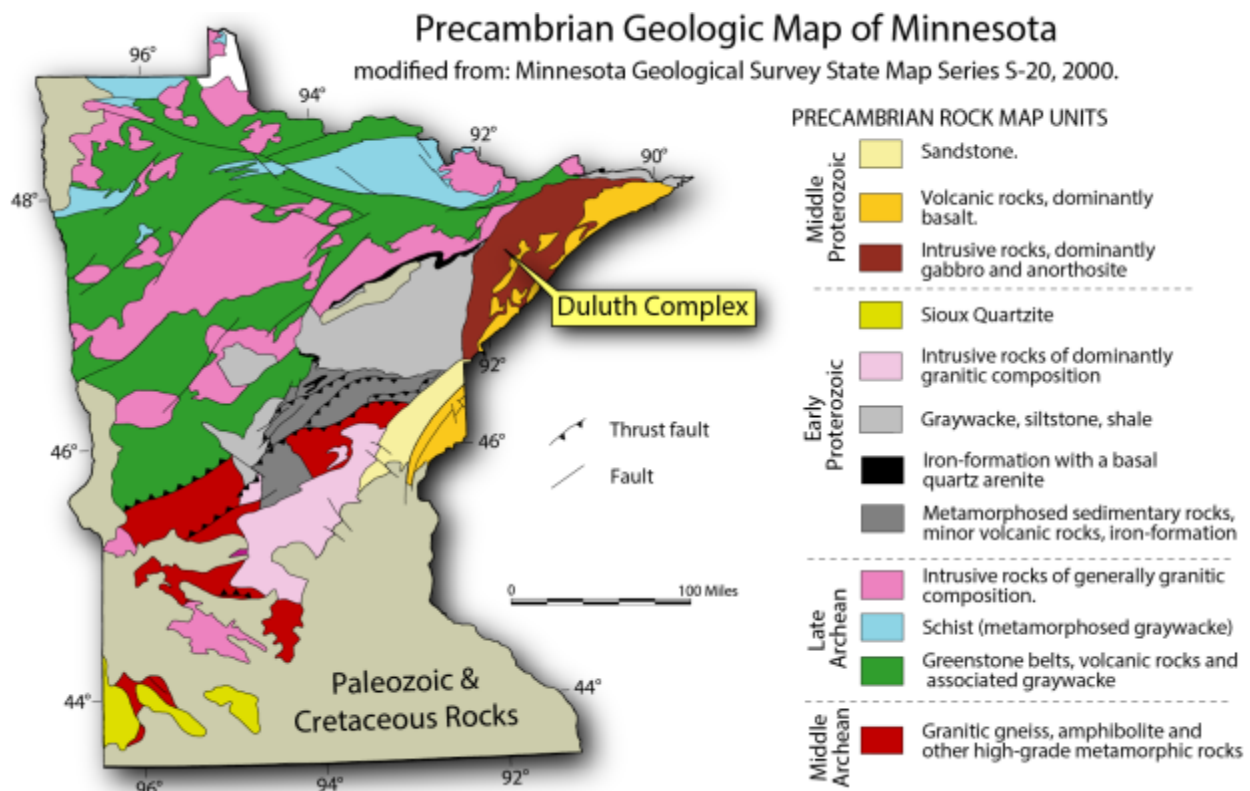

Figure 1: Generalized Precambrian Geologic Map of Minnesota<sup>3</sup>

The mineral ilmenite is an iron-titanium oxide (FeTiO<sub>3</sub>) which is locally concentrated within small oxide-bearing ultramafic intrusions (OUI) associated with the DC, as shown in Figure 2.<sup>4</sup> The OUI contain significant deposits that could be a strategic source of titanium dioxide (TiO<sub>2</sub>) or other titanium-related products. In powdered form, titanium dioxide is used as a white pigment for paints, paper, plastics, rubber, and other materials. Other uses for titanium products include the pharmaceutical and food industries, as well as for the manufacturing of battery

<sup>1</sup> Estimated 1.9 billion years old.

<sup>2</sup> Approximately 1.1 billion years old.

<sup>3</sup> Adapted from Explore Minnesota: Titanium (2015).

<sup>4</sup> Explore Minnesota: Titanium (2015).

products. Titanium metal is used mostly in jet engines, airframes, and space and missile applications. The ilmenite resources in Minnesota are also associated with iron, vanadium, and magnesium. Iron, vanadium, and magnesium products are used for a variety of uses. One of the primary uses is for the production of steel and metal alloys. Magnesium is also used for agricultural, chemical, construction, refractories, environmental and industrial applications, and others.<sup>5</sup>

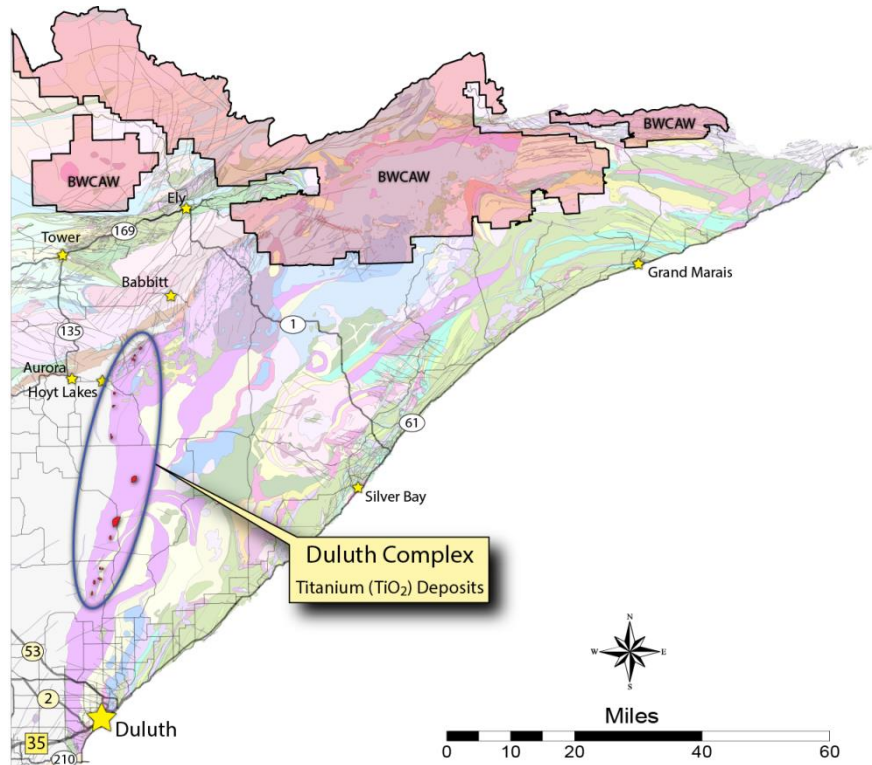

Figure 2: Location of OUIs in Minnesota Duluth Complex

The historic difficulty in processing titanium resources from the OUI resulted from impurities, such as magnesium oxide, in the crude ore and concentrate products. Developing this resource could lead to a new industry for titanium recovery in northeastern Minnesota and position Minnesota as a strategic supplier of this valuable material.

### ***Global Titanium Resource Summary***

Titanium is relatively widely distributed and abundant in the Earth's crust. Primary titanium occurs in igneous rocks and metamorphic titanium-containing rocks. Secondary deposits of titanium include the widely distributed ilmenite placer deposits and ilmenite sands, which mostly occur in coastal regions, and the  $\text{TiO}_2$  deposits in clays. The most important titanium minerals are anatase; ilmenite, and its low iron weathering product leucoxene; perovskite; rutile; and sphene. Of these minerals, only ilmenite, leucoxene, and rutile considered to be of economic importance.<sup>6</sup>

<sup>5</sup> U.S. Geological Survey Magnesium (2017).

<sup>6</sup> U.S. Geological Survey Titanium Statistics and Information (2017).

Major hard rock ilmenite producing areas include Canada, China, Russia, and Norway. China's primary source of hard rock ilmenite is the Panzhihua titaniferous magnetite deposit in Sichuan Province. Canada is the world's third-largest producer of ilmenite. Its primary resource is contained in primary rock deposit in Lac Allard, Quebec, currently being mined by Rio Tinto Fer et Titane (RTFT) for the production of high titania slag. Norway's ilmenite resources are contained in primary rock deposits, the most significant the Tellnes orebody in the south, which is currently being mined by TiZir to produce sulfate-grade ilmenite. Large hard rock deposits of ilmenite in Ukraine have been mined at Irshansk and Vilnohirsk, primarily to provide titanium feedstock for sulfate pigment production in the nearby region and titanium sponge production in both Ukraine and Russia. Titanomagnetite deposits are mainly located in New Zealand, Japan, Sweden, Finland and South Africa.<sup>7</sup>

Mineral sand deposits have been commercially mined in Australia, South Africa, Madagascar, Vietnam, Sierra Leone, the US, and Ukraine. South Africa is the world's second-largest ilmenite producer with widespread resources. The most important mineral sand deposits occur on the east coast, north and south of Richards Bay in KwaZulu-Natal. Australia is the world's fourth-largest producer of ilmenite. The bulk of these resources are associated with mineral sand operations in the Murray Basin of southeastern Australia and on Stradbroke Island in Queensland. Most mineral sand mines in the US are predominantly coastal-type sedimentary deposits on the Atlantic coastal plain, with mines operating in Virginia and Florida.<sup>8,9</sup>

Ilmenite found worldwide in primary massive ore deposits is frequently associated with intermediate composition intrusions. The concentrates obtained from these massive ores often have high iron contents in the form of segregated hematite or magnetite in the ilmenite. The enrichment of ilmenite in beach sand is important for TiO<sub>2</sub> production. The action of surf, currents, and wind result in concentration of the ilmenite and other heavy minerals such as rutile, zircon, monazite<sup>10</sup> in the dunes or beaches. The concentrates obtained from ilmenite sand, being depleted in iron, are generally richer in TiO<sub>2</sub> than those from the massive deposits.

Increasing demand for raw materials with high TiO<sub>2</sub> contents has led to the development of synthetic TiO<sub>2</sub> raw materials like synthetic rutile and titanium slag. Raw materials of this type are produced in Canada by the Rio Tinto Fer et Titane (RTFT), in South Africa by Rio Tinto and Tronox and to a smaller extent in Norway by TiZir.<sup>11</sup> Appendix 1 contains a more detailed global titanium resource review.

### ***Production of Titanium Dioxide Technology Summary***

The mineral ilmenite is the primary source of titanium dioxide, which accounts for about 89% of the global consumption of titanium minerals.<sup>12</sup> There are currently two commercial processes for the production of pigment-grade titanium dioxide from ilmenite: the sulfate process, involving the digestion of the feedstock in sulfuric acid, and the chloride process, which is based

---

<sup>7</sup> Elsner (2010).

<sup>8</sup> Elsner (2010).

<sup>9</sup> U.S. Geological Survey Titanium (2017).

<sup>10</sup> Contains radioactive elements.

<sup>11</sup> Elsner (2010).

<sup>12</sup> U.S. Geological Survey Titanium (2017).

on chlorination in fluidized bed reactors. Both processes rely on using ilmenite ore, synthetic rutile, and/or slag as their feedstock.<sup>13</sup> Figure 3, below, displays the typical feed requirement for pigment plants for the sulfate and chloride processes.

**Feed requirements for pigment plants.**

Attribute	Sulfate	Chloride
Particle size	Not critical	Fines (usually <math>-100\ \mu\text{m}</math>) blown out of fluid bed
Fe	Requires high ferrous content to get high reactivity	Not critical
TiO <sub>2</sub>	Not critical, in ilmenites, need for high FeO leads to TiO <sub>2</sub> lower than 55 per cent	In theory not critical, cost considerations drives to higher TiO <sub>2</sub> ; only one operator commercially treats ilmenite in chloride route
Cr	Low levels required as it follows TiO <sub>2</sub> and spoils pigment colour	Goes to waste and can cause waste disposal constraints
Ca and Mg	Not critical	Causes loss of fluidity in reactor

Figure 3: Typical Feed Requirements for Pigment Plants<sup>14</sup>

The titania slags are produced from ilmenite by smelting using either AC or DC smelting technologies.<sup>15</sup> Synthetic rutile is commercially produced by the Becher and Benilite processes (see Appendix 1 for explanation of these technologies). Figure 4, below, displays the titanium industry feedstock flow for the production of various titanium products.

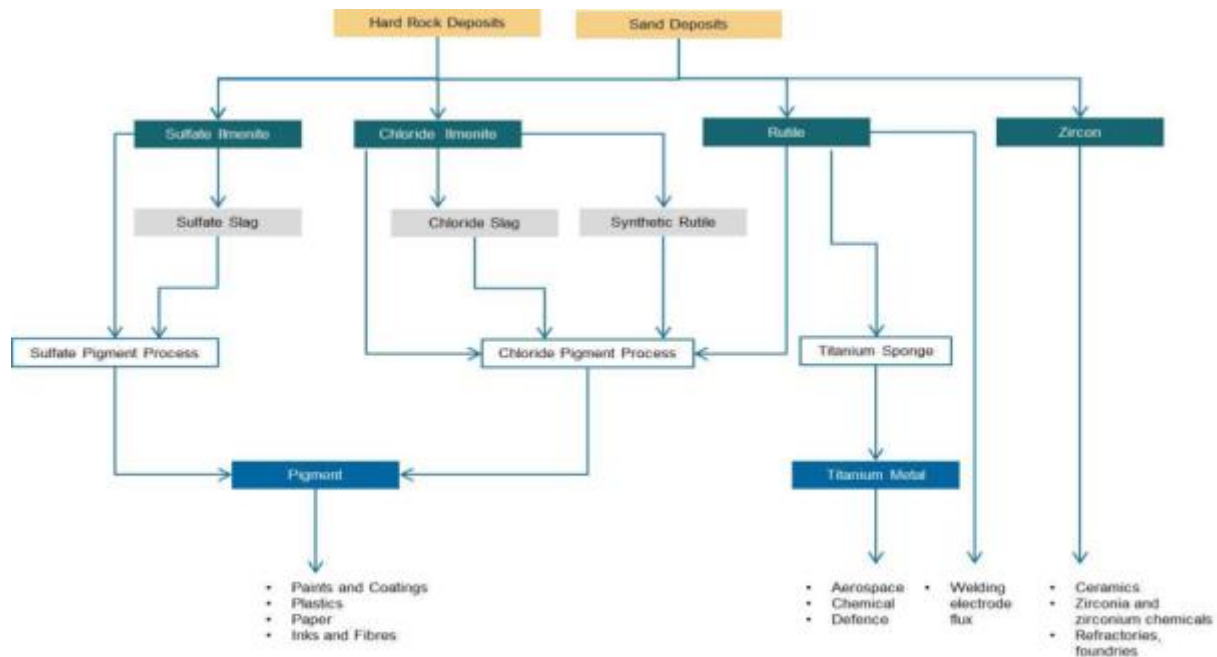

Figure 4: Titanium Industry Feedstock Flow<sup>16</sup>

<sup>13</sup> Elsner (2010).

<sup>14</sup> McManus (2013).

<sup>15</sup> Elsner (2010).

<sup>16</sup> Iluka Resources (2014).

Currently all pigment plants in the USA use the chloride process, which requires low amounts of impurities in the feedstock.<sup>17</sup> Impurities in the raw materials can cause issues with the TiO<sub>2</sub> production process and/or TiO<sub>2</sub> powder characteristics, and may result in deleterious effects such as discoloration of the final TiO<sub>2</sub> product. Appendix 1 contains a more detailed technology review for ilmenite processing technologies.

### ***Titanium Production and Pricing in the United States Market***

Average production, imports, exports, and price data from the previous five years are presented in Table 1, below. No impact of potential mining of ilmenite in Minnesota is reflected by this data.

**Table 1: Average Production, Imports, Exports, and Price Data, 2012-2016<sup>18</sup>**

<b>US - Titanium Mineral Concentrate</b>	<b>Average 2012-2015</b>	<b>2016</b>
Production (Metric Tons)	175,000	100,000
Imports (Metric Tons)	1,105,000	970,000
Exports (Metric Tons)	8,750	4,000
Price (Dollar per Metric Ton), Ilmenite Bulk 54% TiO <sub>2</sub>	\$208	\$105

<b>US - Titanium Dioxide (Pigment Grade)</b>	<b>Average 2012-2015</b>	<b>2016</b>
Production (Metric Tons)	1,225,000	1,200,000
Imports (Metric Tons)	215,250	235,000
Exports (Metric Tons)	656,750	771,000
Producer Price Index*	226	150

\*Note: Average of \$3,143/ton from 2012-2014, with 2013 price of \$2,710/ton<sup>19</sup>

<b>US - Titanium Sponge Metal</b>	<b>Average 2012-2015</b>	<b>2016</b>
Production (Metric Tons)	N/A	N/A
Imports (Metric Tons)	22,975	14,400
Exports (Metric Tons)	1,788	600
Price (Dollar per Kilogram)	\$11.05	\$8.05

Table 2, below, displays a dollar per ton comparison between the average iron ore product and the various potential products from mining and processing of the ilmenite resource.

<sup>17</sup> Including Mg, Ca, Mg, Cr, Fe, Mn, V, SiO<sub>2</sub>, U, Th, and Ra.

<sup>18</sup> Adapted from U.S. Geological Survey Titanium (2017).

<sup>19</sup> Adapted from U.S. Geological Survey Titanium Dioxide Pigment Statistics (2014).

**Table 2: Product Price Comparison**<sup>20,21,22</sup>

<b>Product</b>	<b>2016 Price (US Dollar per Ton)</b>
Average Iron Ore Product	\$82
Titanium Mineral Concentrate	\$105
Iron Oxide (Pigment Grade)	\$1,460
Titanium Dioxide (Pigment Grade)**	\$2,710
Magnesium Metal	\$4,740
Titanium Sponge Metal	\$8,050

\*\*Note: Year 2014 value<sup>23</sup>

### ***Ilmenite Resource in Minnesota***

Activities related to exploration for copper-nickel resources in the Duluth Complex originally identified magnetic and gravity geophysical anomalies that when drilled, led to the discovery of the OUIs in the 1960s. Thirteen OUI bodies are now known to exist, and they occur in a north-south distribution near the western margin of the Duluth Complex, as shown in Figure 5. The titanium resources of the OUI were not recognized until the 1970s. Currently, three of the 13 OUI bodies (Longnose, Water Hen, and Titac) have been studied in enough detail to define titanium resources; two of these intrusions (Longnose, Titac) have NI 43-101 compliant mineral resource estimates. The NI 43-101 resource for the Longnose deposit includes 58 million tons (MT) indicated resource at 16.6% TiO<sub>2</sub> and 65.3 MT inferred resource at approximately 16.4% TiO<sub>2</sub>. The NI 43-101 resource for the Titac deposit includes 45MT of 15% TiO<sub>2</sub> inferred resource.<sup>24,25</sup>

<sup>20</sup> Adapted from U.S. Geological Survey Titanium (2017).

<sup>21</sup> Adapted from U.S. Geological Survey Iron (2017).

<sup>22</sup> Adapted from U.S. Geological Survey Magnesium (2017).

<sup>23</sup> U.S. Geological Survey Titanium Dioxide Pigment Statistics (2014).

<sup>24</sup> Explore Minnesota: Titanium (2015).

<sup>25</sup> Technical Report on the Longnose Ilmenite Project, Minnesota, USA (2012).

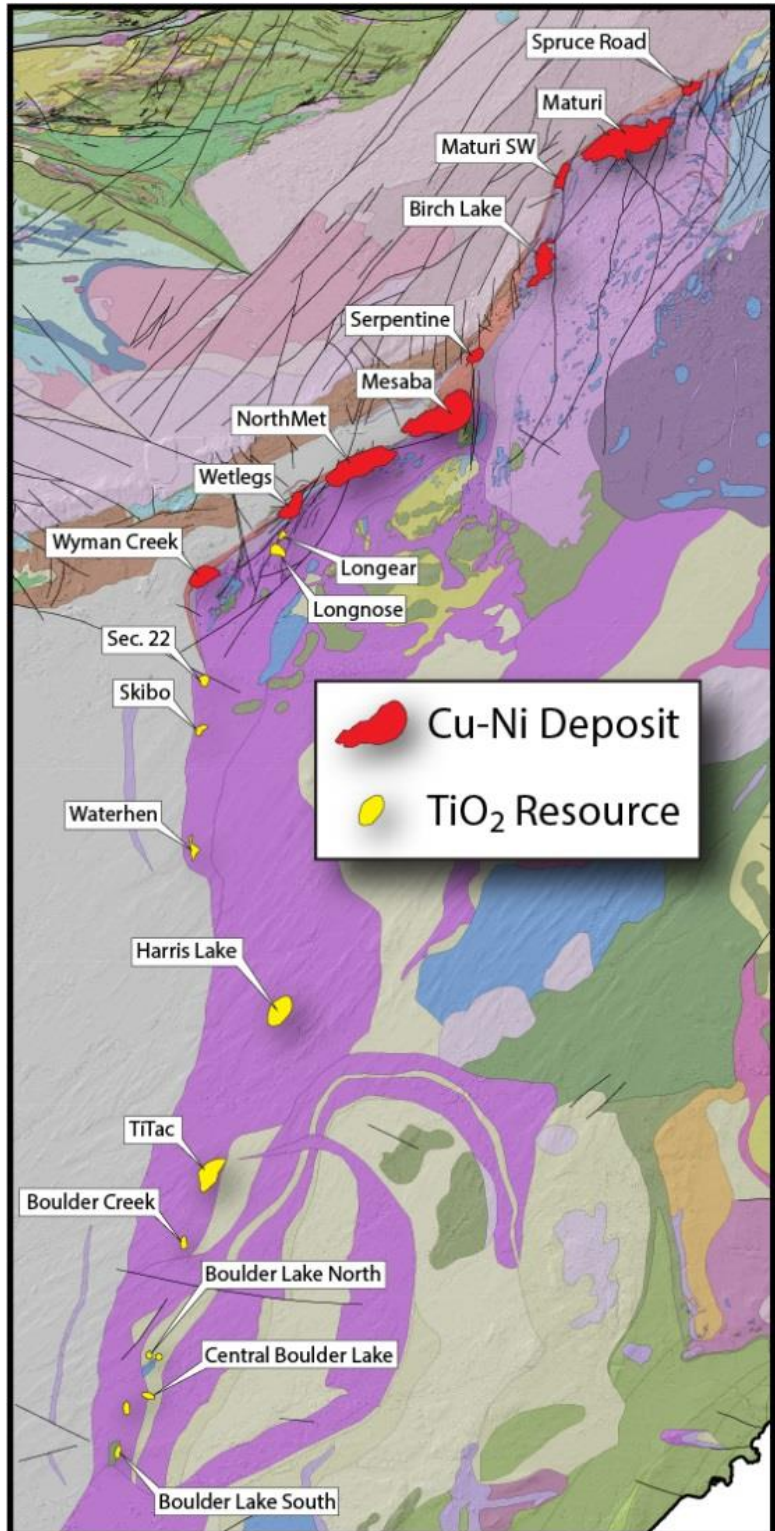

Figure 5: Duluth Complex Mineral Deposits<sup>26</sup>

<sup>26</sup> Adapted from Explore Minnesota: Titanium (2015).

Table 3, below, contains a summary of the ilmenite deposit chemical and resource data available.

**Table 3: Minnesota Ilmenite Drill Core Chemical Analysis and Resource Summary<sup>27</sup>**

Deposit	Drill Holes	Avg. TiO <sub>2</sub> Wt %	Max. TiO <sub>2</sub> Wt %	Avg. V (ppm)	Max. V (ppm)	Resources
Longnose	27	12.49	30.37	1325	4400	58 MMT @ 16.6% TiO <sub>2</sub> (Indicated)
Water Hen	37	11.15	29.30	1065	2285	62 MMT @ 14% TiO <sub>2</sub> (pre-NI 43-101)
Longear	3	18.06	50.50	580	3590	
Titac (Sec. 34)	32	15.66	26.74	2610	4035	45 MMT @ 15% TiO <sub>2</sub> (Inferred)
Sec. 17	6	33 analyses	14.66	790	950	
Sec. 22	2	62 analyses	28.72	1130	2790	
Skibo	9	18 analyses	25.28	165	220	
Skibo South	1	3 analyses	12.6	1100	1346	
Wyman Creek	4	10 analyses	28.65	N/A	540	
Boulder Creek	2	8 analyses	19.09	4630	8125	
Boulder Lake - North	3	6 analyses	35.2	4045	6835	
Central Boulder Lake	1	no analyses	N/A	N/A	N/A	
Boulder Lake - South	3	2 analyses	16.03	N/A	787	

The mineralogy of the OUI includes intergrown coarse-grained ilmenite (FeTiO<sub>3</sub>) and titanomagnetite (Fe<sup>2+</sup>(Fe<sup>3+</sup>, Ti)<sub>2</sub>O<sub>4</sub>); in some groups of OUI, ilmenite is dominant, whereas in others titanomagnetite is dominant. Modal oxide mineral content in the OUI is variable and ranges from 15% to 100% in localized massive oxide mineralized zones. Some of the OUI have Cu-Ni±PGE credits; however, others contain minimal amounts of sulfides. The OUI are characterized by low concentrations of co-products (uranium, thorium, zirconium, rare earth elements) that are typically associated with currently mined placer titanium deposits. Almost all of the OUI are close to the surface and could be amenable to open pit mining with minimal stripping.<sup>28,29</sup>

### ***Previous Ilmenite Processing Research at NRRI***

Previous beneficiation studies with the Longnose ilmenite material at University of Minnesota Duluth Natural Resources Research Institute (NRRI) included spiral separators, high and low intensity magnetic separators, high tension separators, and flotation. NRRI researchers found that Longnose ilmenite samples consisted of ilmenite and magnetite, with the remaining half of the sample being composed of plagioclase feldspar, olivine, and pyroxene. Amphibole, biotite, and serpentine were also found in small amounts. Much of the ilmenite liberated between 2.0 mm and 0.8 mm (10 and 20 mesh).<sup>30</sup>

<sup>27</sup> Explore Minnesota: Titanium (2015).

<sup>28</sup> Explore Minnesota: Titanium (2015).

<sup>29</sup> Severson and Hauck (1990).

<sup>30</sup> Niles (1996).

A combination of gravity, magnetic separation, and electrostatic (high-tension) separation produced an ilmenite concentrate with a chemical assay of approximately 48% TiO<sub>2</sub>, 1% SiO<sub>2</sub>, and 3.7% MgO, but at a recovery of only 50% of the TiO<sub>2</sub>.<sup>31</sup> It was determined that approximately 3.4% of the magnesium oxide (MgO) cannot be removed by beneficiation.<sup>32</sup> NRRI researchers were able to increase the total titanium dioxide recovery by the use of high pressure grinding rolls instead of rod milling, but suffered significant titanium dioxide losses in the gravity and magnetic separation unit operations.<sup>33</sup> Development efforts to recover the mineral values from the Minnesota ilmenite deposits have been hindered due to the high content of magnesium oxide associated with the ilmenite, which generally ranges from two to four percent.<sup>34</sup> This level of magnesium oxide makes a concentrate which is generally unsuitable for many conventional processing schemes.

NRRI has identified an external, proprietary technology that can overcome impurities in the concentrate which may enable development of these Minnesota resources for US strategic purposes. The unique hydrometallurgical technology employed in achieving high purity TiO<sub>2</sub> from Minnesota ilmenite ores was developed and patented by Process Research Ortech (PRO; <http://www.processortech.com/>) located in Mississauga, Ontario, Canada. Prior to the onset of this project, PRO sold the technology to Canadian Titanium Limited (CTL), but is still a partial owner of the technology.<sup>35</sup> The technology involves proprietary atmospheric mixed chloride leaching, solvent extraction, and pyrometallurgical processes that produce a high purity iron and high purity titanium dioxide product that can be directly used as a high value pigment, or alternatively, used as a feedstock for other purposes like titanium metal or lithium titanate for battery development. Initial hydrometallurgical testing with the Longnose ilmenite concentrate samples had acceptable results and therefore was recommended to be researched on pilot-scale. Processing of the ilmenite for titanium may also allow for co-production of materials like vanadium, manganese, and magnesium powders or metals in the future.

---

<sup>31</sup> Benner and Niles (1994).

<sup>32</sup> Benner and Niles (2002).

<sup>33</sup> Benner (2001).

<sup>34</sup> Niles (1996).

<sup>35</sup> This relationship is outlined in the *Intellectual Property Management* section on page 64.

## Project Goals, Objectives, and Deliverables

The primary goal of this project was to prove the technical feasibility of producing high quality iron oxide and titanium dioxide (TiO<sub>2</sub>) products from Minnesota ilmenite using beneficiation combined with Canadian Titanium Limited's (CTL) proprietary hydrometallurgical processing technology. The project was conducted in collaboration with partial owner of the CTL technology: Process Research Ortech (PRO). To accomplish this goal the project objectives were to:

- Produce two-to-three tons of titanium concentrate at NRRI and send a large sample of this material to PRO for bench- and pilot-scale hydrometallurgical testing,
- Produce a variety of iron and titanium products for market evaluation at PRO,
- Scout production of vanadium and magnesium products in addition to iron and titanium products, and
- Conduct a high-level CAPEX/OPEX study for the process.

The project deliverables included producing up to 10 kg of high-purity titanium dioxide powder for market evaluation and reporting the technical results with future testing recommendations. The NRRI also expanded the scope to include additional iron product development, a titanium dioxide powder purity optimization study, and a titanium dioxide product marketing study.

## Materials and Methods

### *Testing Sample*

An approximate 100-ton stockpile of ilmenite material located at the NRRI Coleraine Laboratory (Coleraine, Minnesota), was the sample chosen for testing. The stockpile consisted of remaining Longnose deposit material that was used for previous metallurgical studies in the 1990's and 2000's.<sup>36</sup> The Longnose bulk sample was obtained from an outcrop of the Longnose OUI at the following coordinates (UTM NAD83) 572,025 East, 5,268,650 North. The original purpose of the bulk sample was to produce an ilmenite concentrate that was amenable to the production of synthetic rutile.<sup>37</sup> A three-dimensional conceptual grade shell model was assembled using legacy Longnose drilling data and the bulk sample site was located. Figure 6, below, shows the Longnose ilmenite conceptual grade shell model.

---

<sup>36</sup> Technical Report on the Longnose Ilmenite Project, Minnesota, USA (2012).

<sup>37</sup> Patelke and Severson (2005).

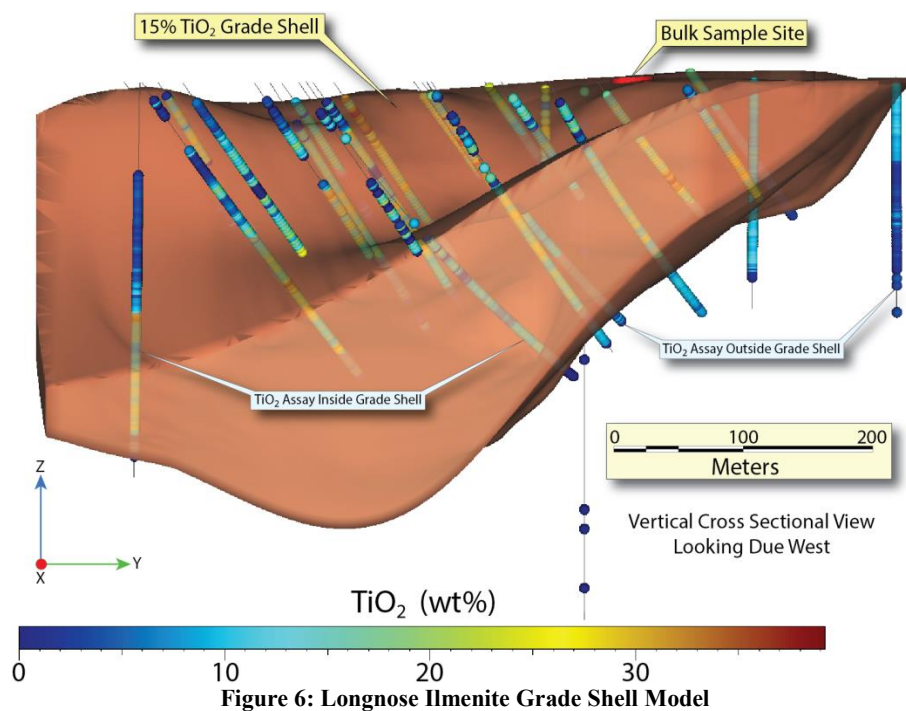

Figure 6: Longnose Ilmenite Grade Shell Model

Historical characterization of the Longnose deposit mineralogy has coarse-grained ilmenite, titaniferous magnetite, and magnetite as the desired ore minerals and silicates (such as olivine) as the major gangue components.<sup>38</sup>

### ***Beneficiation Flowsheet Selection***

A literature review was conducted by NRRI on processing of Minnesota ilmenite. NRRI researchers produced an ilmenite concentrate with a grade of 40%  $\text{TiO}_2$  and over 60%  $\text{TiO}_2$  recovery could be produced by the following flowsheet:

1. Crude ore crushing,
2. Single-stage high pressure grinding roll (HPGR) processing,
3. Two-stage spiral separation, and
4. Single-stage low intensity magnetic separation.<sup>39</sup>

The graphical flowsheet and metallurgical balance from this study can be found in Appendix 2.

A modified beneficiation flowsheet was adapted from this study for generating a bulk ilmenite concentrate for hydrometallurgical testing. The expected grade of the titanium concentrate was approximately 39%  $\text{TiO}_2$  with a recovery of greater than 70%  $\text{TiO}_2$ . There were three expected products from the beneficiation flowsheet: ilmenite concentrate, magnetite/titanomagnetite concentrate, and high silica tailings. The magnetite and titanomagnetite material was removed from the ilmenite concentrate to reduce the iron hydrolysis cost in the hydrometallurgy process.

<sup>38</sup> Niles (1996).

<sup>39</sup> Benner (2001).

### *Hydrometallurgical Testing Program*

Process Research Ortech (PRO) was contracted to test the proprietary CTL leaching and solvent extraction technology<sup>40,41</sup> with the ilmenite concentrate produced at NRRI on bench- and pilot-scale. The NRRI employed PRO to conduct testing related to mineralogy, leach and solvent extraction bench testing, leach and solvent extraction pilot testing, production of titanium dioxide and iron oxide powder products, and CAPEX/OPEX design estimates. The CTL process consists of atmospheric chloride leach followed by solvent extraction of iron, titanium, and other elements successively. A high purity titanium bearing strip solution is produced and can be used to produce titanium products dependent on the end market use such as high purity TiO<sub>2</sub> for the pigment, pharmaceutical, or food industry. Other products that can be obtained from the process are high purity Fe<sub>2</sub>O<sub>3</sub> powder for pigment or iron production or vanadium alloys if the sample contains vanadium.

The CTL process is a flexible process as it can be applied to a wide range of feed stocks, especially those with magnesium, vanadium, and chromium not treatable by other current methods. The CTL process does not employ exotic unit operations nor are exotic materials required for construction. In addition, the process is environmentally friendly as the reagents are recycled and the residue is inert. The solid residue can also potentially be used for applications such as road fill. There is no need to handle chlorine- and carbon-containing chemicals at high temperature as in other processes. The proposed flowsheet for this testwork is presented in Figure 7, below.

---

<sup>40</sup> US Patent No. 7,803,336 B2, Canadian Patent No. 2,513,309 and Australian Patent No. 2004291568.

<sup>41</sup> PRO has a technology licensing agreement with other entities. This relationship is outlined in the Intellectual Property Management section on page 67.

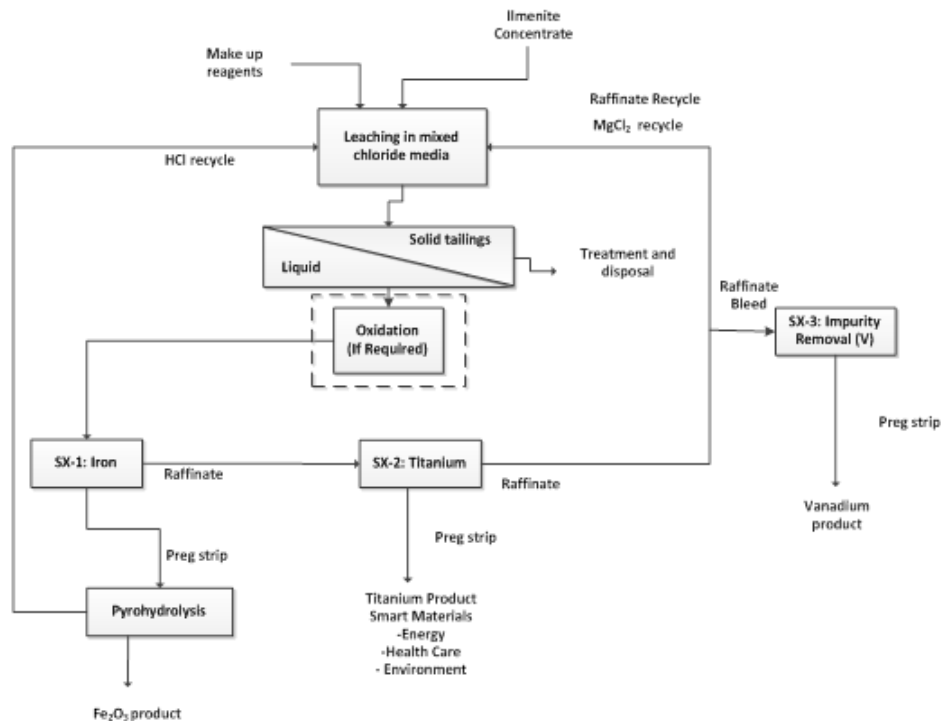

Figure 7: Proposed Hydrometallurgical Flowsheet from PRO

### Characterization Methods

The analyses for the test program were conducted by the following methods at NRRI:

- Sample preparation for chemical analysis: 95% passing 74 microns with ring mill
- Fe: titration
- Magnetic Fe: Satmagan
- $\text{TiO}_2/\text{SiO}_2/\text{MgO}/\text{V}_2\text{O}_5$ : ICP-OES
- Size analyses: Gilson-style sieves with rotap

Sampling of aqueous and solid samples from bench scale and pilot testing was used to determine leach as well as solvent extraction efficiencies. Aqueous samples were tested in the PRO laboratory using inductively coupled plasma (ICP) while solid samples were analyzed using X-ray fluorescence (XRF) at PRO. Some of the solid samples were also analyzed using multi acid digestion. A number of samples were sent to a third-party laboratory, AGAT Laboratories of Mississauga, ON, for XRF<sup>42</sup> and ICP-OES<sup>43</sup> analysis. PRO's chemical assay details can be found in Appendix 3.

Quantitative evaluation of minerals by scanning electron microscope (QEMSCAN) and optical microscopy analyses on the as-is testing sample were conducted by Integrated Process Mineralogy Solutions of Mississauga, Ontario, Canada. Reflective light optical microscopy and

<sup>42</sup> Lithium borate fusion – summation of oxides, XRF finish (201-676).

<sup>43</sup> 4 acid digest – metals package, ICP-OES finish (201-070).

X-ray diffraction (XRD) testing on pilot-scale products were conducted by Dr. Rodney Johnson of Rod Johnson and Associates of Negaunee, Michigan, USA.

## Results

### *Sample Preparation*

Approximately ten metric tons of 25 mm (one inch) Longnose ilmenite sample was taken from the stockpile at NRRI Coleraine Laboratory and six-way split using a rotary barrel splitter. During rotary blending process three buckets of sample were taken and blended to form a composite head sample. This sample was used for the head sample characterization discussed below.

### *Sample Characterization*

#### Chemical Analysis

Characterization of the testing sample was conducted at NRRI as well as at PRO. ICP-OES analysis was conducted at NRRI. PRO contracted AGAT Laboratories to conduct XRF and ICP-OES analyses. Some testing samples were also analyzed internally at PRO during the bench and pilot operations. The results by NRRI and AGAT are presented in Table 4.

**Table 4: Chemical Analyses at NRRI and AGAT**

	Total Fe (%) <sup>44</sup>	Fe <sub>2</sub> O <sub>3</sub> (%)	TiO <sub>2</sub> (%)	SiO <sub>2</sub> (%)	MgO (%)	V <sub>2</sub> O <sub>5</sub> (%)
NRRI	28.18	N/A	25.23	15.42	13.47	0.27
AGAT	N/A	40.2	25.4	16.6	13.8	0.25

NRRI found magnetic iron readings of 5.49%. The trace analysis at AGAT found relatively low levels of sulfur (0.1%), copper (0.18%), and phosphorus content (80 ppm) in the testing sample. Appendix 4 contains the full chemical analysis by AGAT Laboratories.

#### Mineralogical and Liberation Analyses

PRO employed Dr. Aparup Chattopadhyay of Integrated Process Mineralogy Solutions (IPMINS) to conduct QEMSCAN and optical microscopy analyses. The sample was prepared to 80% passing (“P80”) 150 microns (100 mesh) via ball milling and submitted for analysis. The QEMSCAN analysis showed that the sample consisted of ilmenite (50%) and iron oxides (5%), with the majority of gangue consisting of olivine, serpentine, pyroxene/amphiboles, chlorites, and talc (40%). The modal mineral analysis is presented in Table 5, below, and the full QEMSCAN report can be found in Appendix 5.

---

<sup>44</sup> Assay conducted via titration.

Table 5: Mineralogy of Longnose Ilmenite Head Sample

Mineral Abundance	Pure Chemical Formula	Head Wt %
Ilmenite	FeTiO <sub>3</sub>	51.9
Olivine	(Mg,Fe) <sub>2</sub> SiO <sub>4</sub>	26.7
Serpentine	Mg <sub>3</sub> (OH) <sub>4</sub> (Si <sub>3</sub> O <sub>5</sub> )	5.6
Iron Oxides <sup>*1</sup>	Requires Speciation	5.0
Pyroxene/Amphibole	Requires Speciation	3.4
Chlorite	Requires Speciation	2.6
Talc	Mg <sub>3</sub> Si <sub>4</sub> O <sub>10</sub> (OH) <sub>2</sub>	1.8
Quartz	SiO <sub>2</sub>	0.6
Calcite	CaCO <sub>3</sub>	0.6
Feldspar	Requires Speciation	0.5
Cu-sulphides <sup>*2</sup>	Cu <sub>x</sub> S <sub>y</sub>	0.1
Muscovite	KAl <sub>2</sub> (AlSi <sub>3</sub> O <sub>10</sub> )(F,OH) <sub>2</sub>	0.1
Rutile/anatase	TiO <sub>2</sub>	0.1
Pyrite	FeS <sub>2</sub>	0.0
Others <sup>*3</sup>	Requires Speciation	0.9
<b>Total</b>		100.0

\*<sup>1</sup>:including hematite, goethite, magnetite and limonite.

\*<sup>2</sup>:including chalcopyrite, bornite, covellite and chalcocite

\*<sup>3</sup>:including barite, apatite, Cu-sulphate/oxides/carbonates & sphalerite

Approximately 80% of the ilmenite was at least 95% liberated, whereas only 15% of the iron oxides were liberated at the 80% passing (“P80”) 150 microns grind. Optical microscopy showed the presence of fine ilmenite locked in silica, as shown in the photomicrographs in Appendix 6 (see plate 3).

### ***Beneficiation Testing Summary***

A small bench-scale beneficiation testing program was conducted to confirm the expected results. Figure 8, below, displays the results of this test program. As can be seen in the figure, the bench results simulated the results from the study by Benner in 2001. The modified flowsheet for this study showed the potential to increase the titanium recovery approximately 10-15% compared to the previous study, as can be seen as the red line in Figure 8.

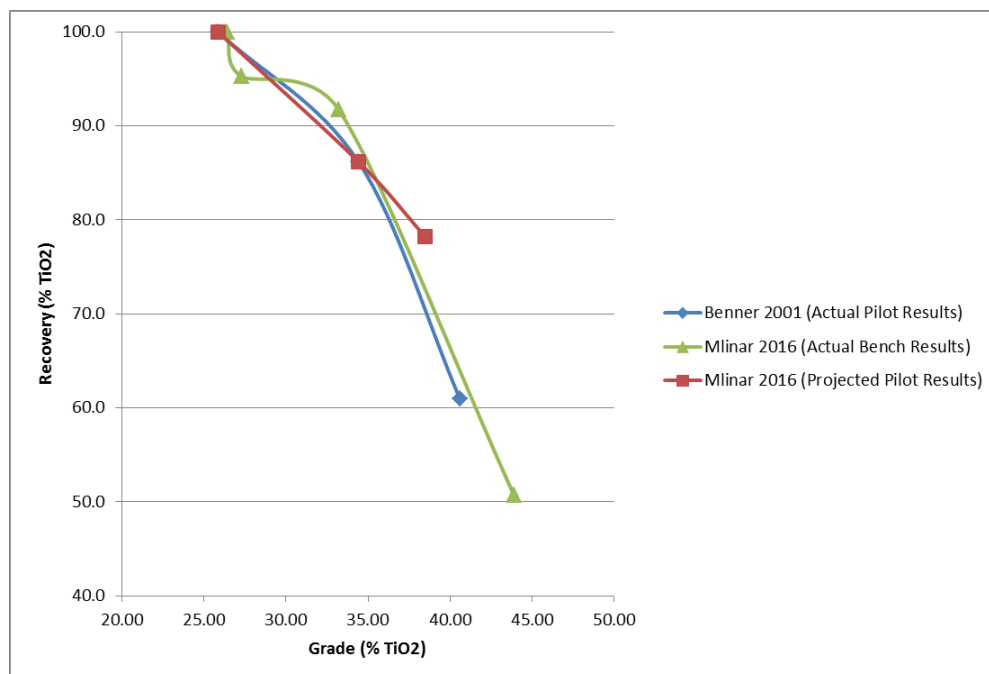

Figure 8: Actual Bench and Pilot Results vs. Projected Results

After confirming the modified flowsheet was appropriate for producing bulk materials at pilot-scale, a total of approximately ten tons of ilmenite material was beneficiated using the chosen process flowsheet at NRRI. Total grinding energy consumption was estimated at 21.1 kWh per ton. The ilmenite concentrate product was found to contain approximately 38.9% TiO<sub>2</sub>, 31.1% Total Fe, 6.4% SiO<sub>2</sub>, 7.6% MgO, and 0.32% V<sub>2</sub>O<sub>5</sub> with an estimated weight recovery of 45.5% and a TiO<sub>2</sub> recovery of 71.3%. Appendix 7 contains the metallurgical balance for the beneficiation process.

Figure 9, below, displays the comparative results of the pilot-scale testing. As can be seen in the figure, the titanium recovery from the modified beneficiation flowsheet was lower than projected but showed higher recovery than in the study by Benner in 2001. The modified pilot flowsheet produced an ilmenite concentrate with 10% higher titanium recovery at a slightly lower concentrate grade as compared to the previous study.

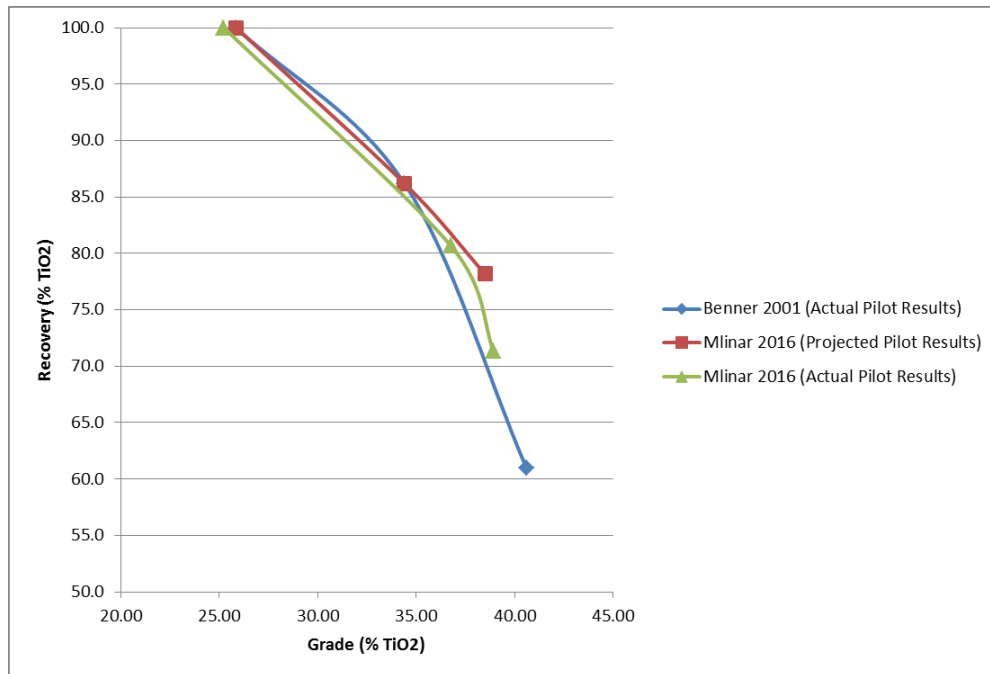

Figure 9: Projected Pilot Results vs. Actual Pilot Results

Approximately 1.5 tons of ilmenite concentrate sample was submitted to PRO for hydrometallurgical testing while the remainder of the ilmenite concentrate, magnetite/titanomagnetite concentrate, and high silica tailings were retained at NRRI for additional characterization and testing.

***Characterization of Beneficiation Pilot Products***

The products from the beneficiation studies were characterized by size, specific gravity, and mineralogy (XRD and reflective light optical microscopy). The beneficiation pilot product sizing data are presented in Figure 10, below. The ilmenite concentrate was found to have a P80 of 54 microns. The detailed product sizing can be found in Appendix 8.

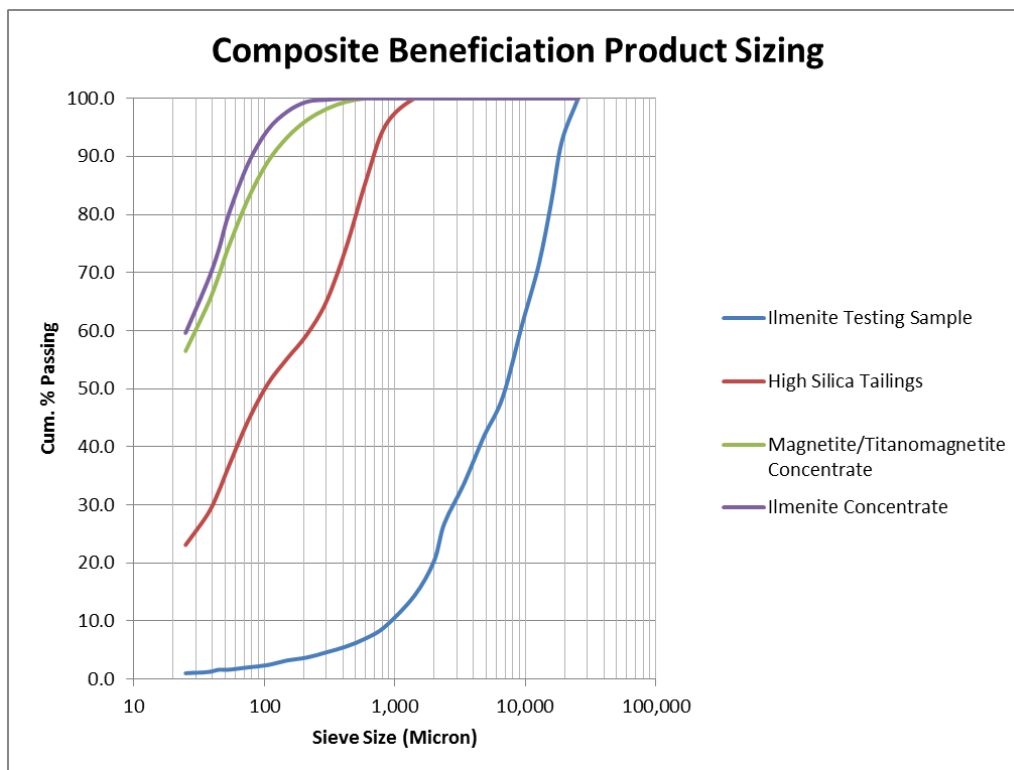

Figure 10: Beneficiation Composite Product Sizing

The specific gravity of each of the products is presented in Table 6, below.

Table 6: Specific Gravity of Pilot Products

Sample	Specific Gravity
Ilmenite Testing Sample	3.6380
High Silica Tailings	3.0892
Magnetite/Titanomagnetite Concentrate	4.4089
Ilmenite Concentrate	4.1897

A representative sample of each of the products was provided to Dr. Rodney Johnson and Associates for a detailed mineral identification via XRD and reflective light microscopy. The following is an excerpt from the mineralogy report:

“All samples contain minerals characteristic of a serpentinized oxide-rich ultramafic rock. The samples contain varying amounts of the silicates lizardite (and/or antigorite), chlorite, plagioclase (possibly anorthite), hornblende, and talc and the oxides ilmenite and magnetite. Trace amounts of hematite and chalcopyrite were also observed. Chalcopyrite is variably replaced by bornite and covellite.

Ilmenite and magnetite occur as primary magmatic and secondary minerals. Primary ilmenite is typically coarse-grained and contains minor amounts of hematite exsolution lamellae. Secondary ilmenite occurs as fine-grained inclusions in silicates that probably formed by exsolution from the silicate

minerals. Primary magnetite occurs as magnetite and titanomagnetite. Primary magnetite is much more abundant than titanomagnetite. Secondary magnetite does not contain ilmenite exsolution lamellae. Secondary magnetite is very fine-grained and occurs in lizardite and formed during serpentinization.

The silicates lizardite (and/or antigorite) and chlorite are formed by the alteration of primary olivine and pyroxene. Titanomagnetite contain exsolution lamellae of ilmenite, but only occurs in trace amounts.”

Semi-quantitative mineralogy for each pilot-scale product was compiled from the XRD and optical microscopy data. Table 7, below, displays the mineralogy of the pilot-scale beneficiation circuit. Table 7 shows the majority of the ilmenite concentrate product consisted of ilmenite with gangue constituents of lizardite, chlorite, and hornblende. The magnetite/titanomagnetite product consisted primarily of magnetite, however, also consisted of a relatively high degree of ilmenite (36%) with lesser amounts of lizardite and chlorite. The high silica tailings product consisted of a varied amount of gangue (lizardite, chlorite, talc, hornblende, and anorthite), but also consisted of 17% ilmenite and 11% magnetite.

**Table 7: Estimated Mineralogical Balance on Beneficiation Pilot Products**

Phase	Pure Chemical Form	Ilmenite Testing Sample	High Silica Tailings	Magnetite/Titanomagnetite Concentrate	Ilmenite Concentrate
		Wt %	Wt %	Wt %	Wt %
Ilmenite	FeTiO <sub>3</sub>	34.9	16.6	36.4	85.9
Magnetite	Fe <sub>3</sub> O <sub>4</sub>	14.0	10.9	47.8	N/A
Lizardite	Mg <sub>3</sub> Si <sub>2</sub> O <sub>5</sub> (OH) <sub>4</sub>	25.1	19.7	4.8	3.7
Chlorite	(Mg,Fe) <sub>3</sub> (Si,Al) <sub>4</sub> O <sub>10</sub>	21.9	22.2	11.0	4.6
Talc	(OH) <sub>2</sub> ·(Mg,Fe) <sub>3</sub> (OH) <sub>6</sub>	N/A	4.4	N/A	N/A
Hornblende	Ca <sub>2</sub> (Mg,Fe,Al) <sub>5</sub> (Al,Si) <sub>8</sub> O <sub>22</sub> (OH) <sub>2</sub>	N/A	15.8	N/A	5.8
Anorthite	CaAl <sub>2</sub> Si <sub>2</sub> O <sub>8</sub>	4.0	10.4	N/A	N/A
<b>Totals</b>		<b>99.9</b>	<b>100.0</b>	<b>100.0</b>	<b>100.0</b>

A mineral balance for the ilmenite and magnetite was compiled from the data generated from the XRD and optical microscopy and from the pilot-scale weight recoveries. The result of this balance is shown in Table 8, below.

**Table 8: Ilmenite and Magnetite Balance on Pilot-Scale Products**

Phase	Pure Chemical Form	Ilmenite Testing Sample	High Silica Tailings	Magnetite/Titanomagnetite Concentrate	Ilmenite Concentrate
		Dist %	Dist %	Dist %	Dist %
Ilmenite	FeTiO <sub>3</sub>	100.0	31.5	4.6	63.8
Magnetite	Fe <sub>3</sub> O <sub>4</sub>	100.0	17.6	82.4	0.0

Dr. Rodney Johnson pointed to losses of fine primary ilmenite and secondary ilmenite locked in gangue particles in the gravity separators and some ilmenite losses to the magnetite/titanomagnetite stream. Overall ilmenite recovery to the ilmenite concentrate stream was estimated at 64%.

### ***Bench-Scale Hydrometallurgical Processing Testing***

PRO was tasked to complete characterization, bench-scale hydrometallurgical testing, and pilot-scale hydrometallurgical testing with the ilmenite concentrate produced at NRRI. The ultimate goal was to produce iron and titanium products for evaluation and to determine a high-level estimate of capital and operational expenditures for this process.

#### Chemical Analysis of Leach Feed

Characterization of the ilmenite concentrate was conducted at PRO as a comparison. PRO contracted AGAT Laboratories to conduct XRF and ICP-OES analyses. The results by NRRI and AGAT are presented in Table 9.

**Table 9: Chemical Analyses at NRRI and AGAT**

	Total Fe (%)	Fe <sub>2</sub> O <sub>3</sub> (%)	TiO <sub>2</sub> (%)	SiO <sub>2</sub> (%)	MgO (%)	V <sub>2</sub> O <sub>5</sub> (%)
NRRI	31.09	N/A	38.93	6.43	7.57	0.32
AGAT	N/A	45.00	40.10	7.49	8.00	0.33

Appendix 9 contains the full chemical analysis by AGAT Laboratories.

#### Bench-Scale Leach and Oxidation Testing

Bench-scale leaching of the concentrate was conducted using CTL's mixed chloride process which uses a lixiviant containing magnesium chloride (MgCl<sub>2</sub>) and hydrochloric acid (HCl). The lixiviant leaches the target elements as follows:

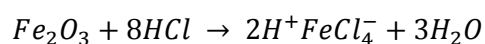
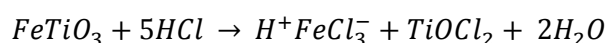

Initially, the concentrate was used as received. An initial leach test was conducted for six hours to determine the optimum residence time for the leaching process. Based on the results displayed in Figure 11 it was determined that four hours is required for leaching of the ilmenite concentrate material.

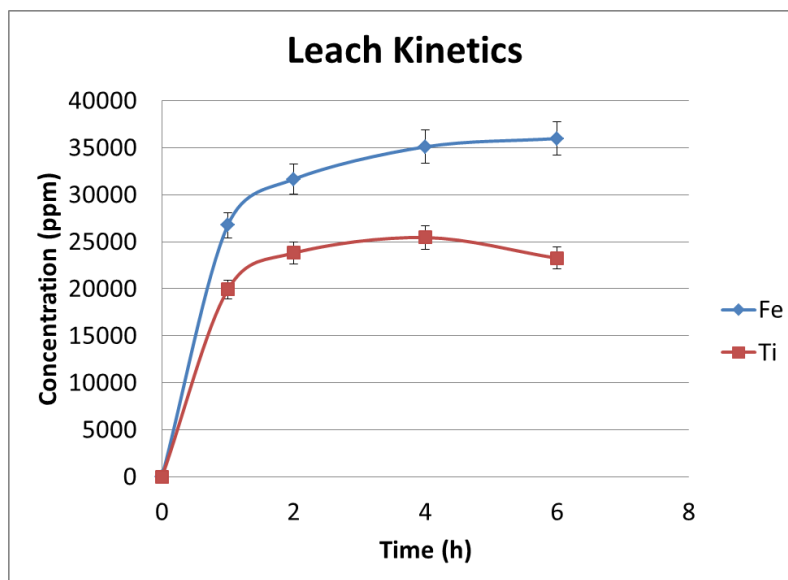

Figure 11: Bench-Scale Leach Kinetics Test Results

Leach optimization testing was conducted on bench-scale. PRO determined that finer grinding of the material improved the leach efficiency of both iron and titanium and therefore the ilmenite concentrate was recommended to be reground to 80% passing 37 microns (400 mesh). Regrind and leaching testing showed an average of 89% and 88% leach efficiency for iron and titanium, respectively. The ilmenite concentrate regrind was estimated to consume 5.8 kWh per ton; therefore, total grinding energy consumption was estimated at 26.9 kWh per ton. Oxidants were added in an attempt to improve leaching efficiencies; these reagents were found to result in minimal improvement. The bench-scale PLS samples were oxidized to convert  $\text{Fe}^{2+}$  to  $\text{Fe}^{3+}$  by sparging  $\text{O}_2$  gas into a mixing tank containing the PLS in preparation of iron extraction.

#### Bench-Scale Iron Solvent Extraction

Applying PRO's knowledge of the mixed chloride leaching system, an organic composition was determined which would selectively extract iron from the pregnant leach solution (PLS). Testing was conducted to produce isotherms for the extraction and stripping sections of the iron circuit, which are displayed in Figure 12 and Figure 13. For the extraction isotherm, the organic phase was mixed with PLS produced from the bench scale leaching tests. The theoretical stages required to operate a continuous counter-current process was found to involve three extraction stages and three stripping. These were determined by the organic-to-aqueous ratio (O:A) plots seen in Figure 12 and Figure 13, below.

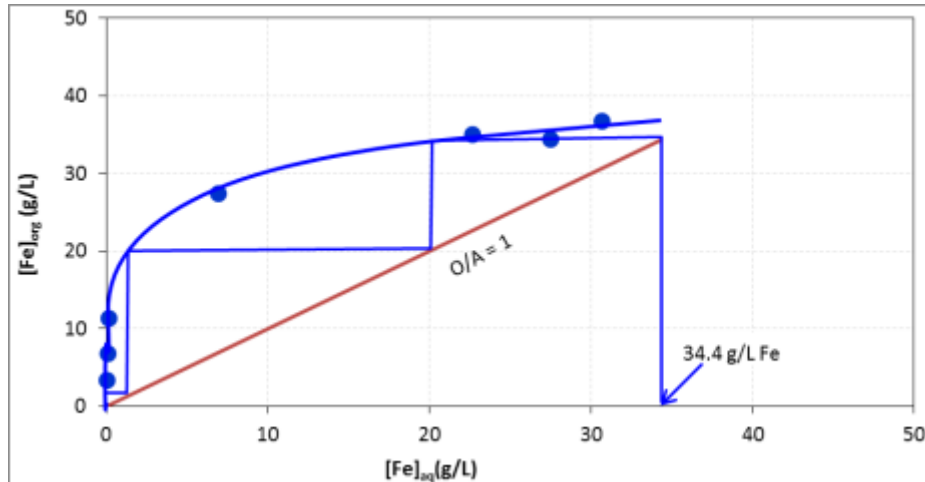

Figure 12: Iron Extraction Isotherm

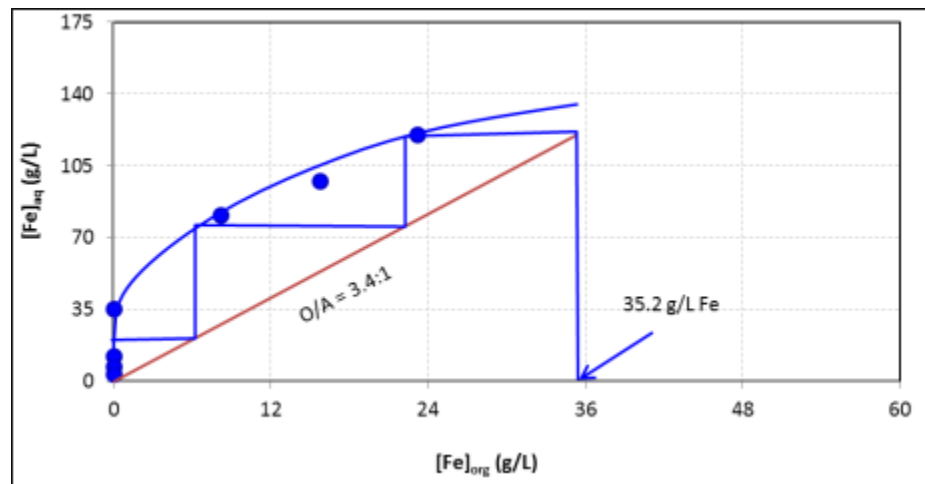

Figure 13: Iron Stripping Isotherm

### Bench-Scale Titanium Solvent Extraction

Applying PRO’s knowledge of the mixed chloride leaching system, an organic composition was determined which would selectively extract titanium from the iron circuit raffinate. Testing was conducted to produce isotherms for the extraction and stripping sections of the titanium circuit which are displayed in Figure 14 and Figure 15. The pre-conditioned organic phase was then mixed with iron circuit raffinate for the extraction isotherm. The theoretical stages required to operate a continuous counter-current process was determined to be three extraction stages and at least seven stripping.

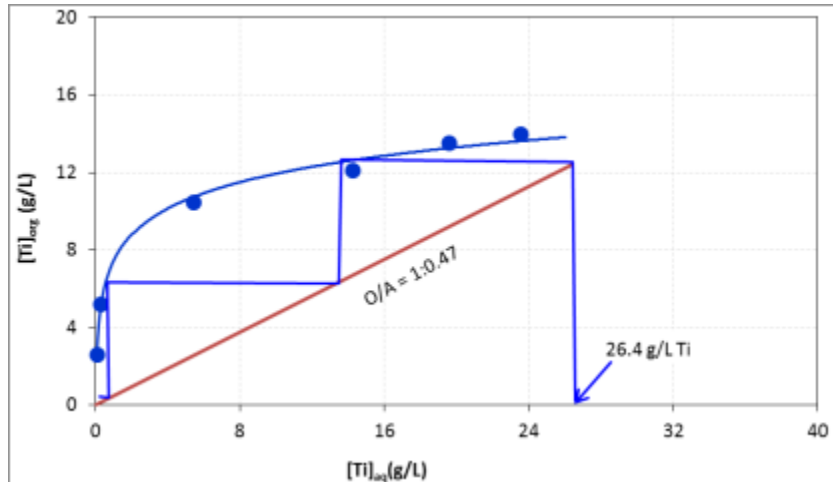

Figure 14: Titanium Extraction Isotherm

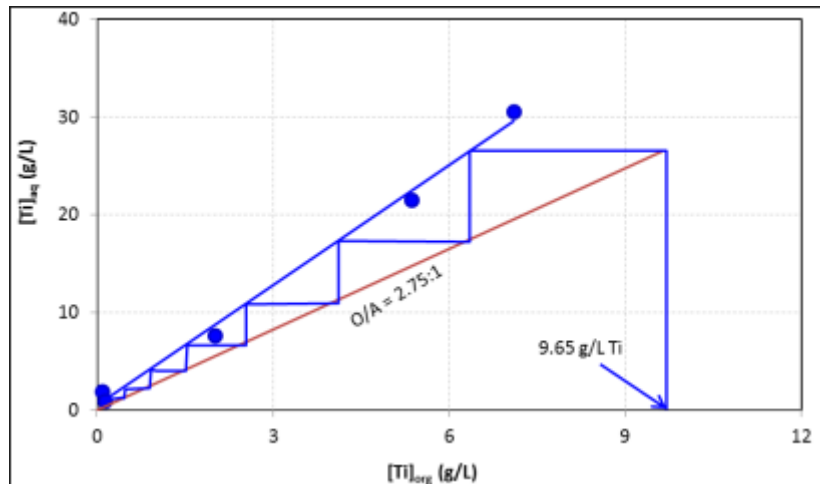

Figure 15: Titanium Stripping Isotherm

Proposed Process Flowsheet for Pilot-Scale Testing

Figure 16, below, shows the overall process flowsheet for the recovery of value metals from ilmenite concentrate. The black arrows indicate solid flow through the circuit; the blue arrows indicate aqueous flow through the circuit; and the red arrows indicate organic flow through the circuit.

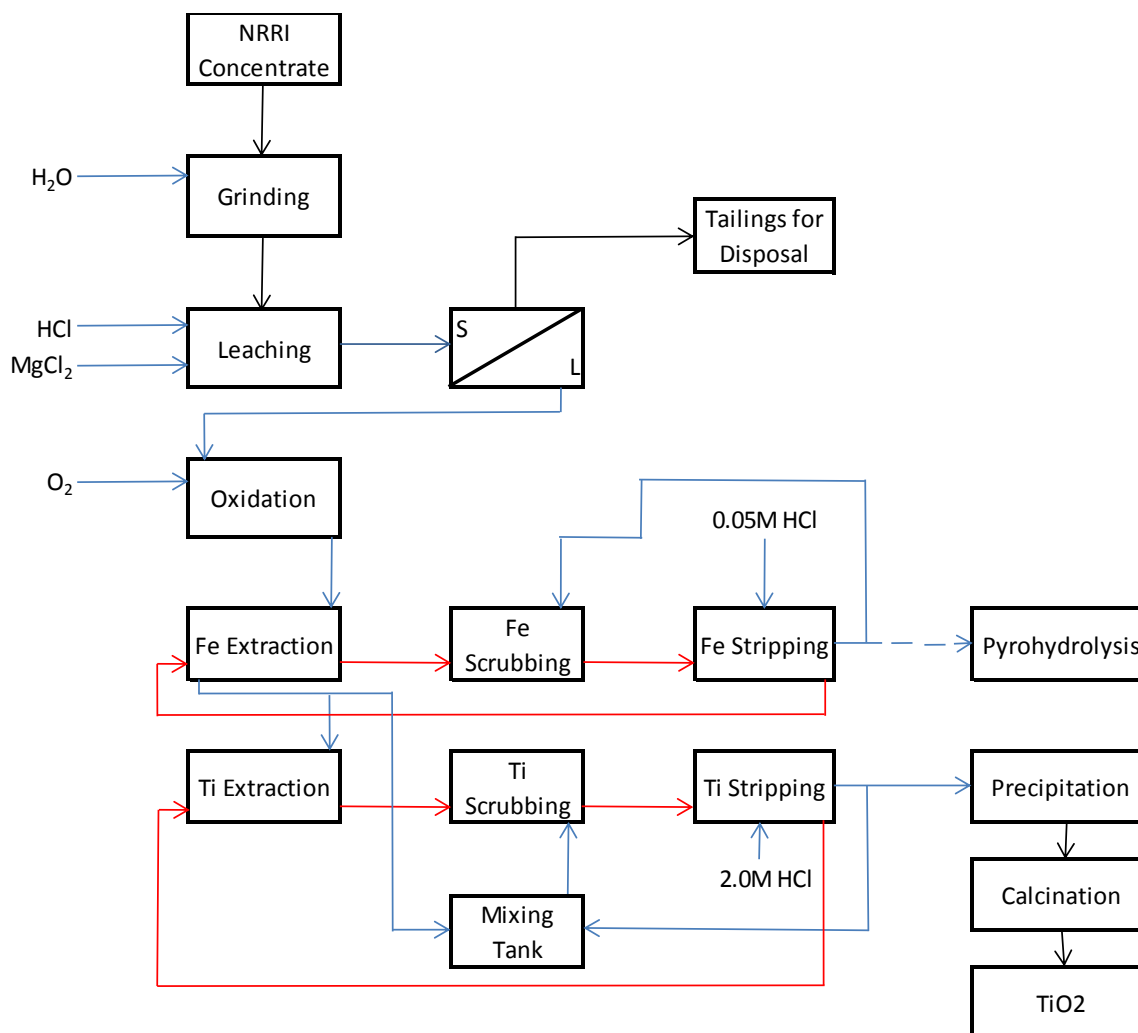

Figure 16: Proposed Pilot-Scale Hydrometallurgical Process Flowsheet

The process flowsheet can be divided into the following steps:

1. **Sample Preparation:** The first step in the process is beneficiation of the ore to produce an ilmenite concentrate. Size should be approximately 80% passing 37 microns (400 mesh).
2. **Mixed Chloride Leaching:** The ground ilmenite concentrate is leached at atmospheric pressure at 70°C in a mixed chloride lixiviant. The slurry is then filtered and the tailings are properly disposed. Pregnant leach solution (PLS) obtained from leaching undergoes oxidation for the conversion of ferrous chloride to ferric chloride. Following oxidation, successive solvent extraction stages are conducted to recover iron and titanium.
3. **Oxidation:** Following the filtration of the PLS, it is pumped into columns into which oxygen gas (O<sub>2</sub>) is sparged to oxidize Fe<sup>2+</sup> to Fe<sup>3+</sup>.

4. Iron Solvent Extraction: The PLS is contacted with an organic extractant to selectively extract iron into the organic phase. The loaded organic is scrubbed with a high iron containing solution and then stripped by contacting with a stripping solution to generate iron-rich strip liquor.
5. Titanium Solvent Extraction: The raffinate from iron solvent extraction is contacted with an organic extractant to selectively extract titanium into the organic phase. The loaded organic is scrubbed with a high titanium containing solution and then stripped by contacting with a stripping solution to generate titanium-rich strip liquor.
6. Titanium Dioxide Precipitation: Titanium dioxide is precipitated from titanium-rich pregnant strip liquor by thermal precipitation.
7. Pyrohydrolysis: Iron oxide is produced and hydrochloric acid is regenerated via pyrohydrolysis of iron-rich pregnant strip liquor. Magnesium oxide is produced and hydrochloric acid is regenerated by pyrohydrolysis of a bleed stream from the raffinate of titanium solvent extraction. Regenerated hydrochloric acid is recycled to the process.<sup>45</sup>
8. Aqueous Stream Recycle: The CTL flowsheet is based on the recycling of aqueous streams. After the PLS has passed through the appropriate number of extraction circuits it is required to be reconstituted to the same lixiviant compositions that are used for leaching. This is achieved in a commercial plant by using appropriate levels of evaporation, bleeding, and acid addition. This portion of the testing was conducted at bench scale with results found in the *Pilot Plant to Production Scale* section, below.
9. Inert Tailings: The leach residue was tested for Ontario regulation 558: metals and inorganics, by a third-party to determine if it met environmental standards. By using the CTL mixed chloride leaching process, the tailings produced were considered inert per the regulation 558 test. The results of the test are presented in the *Tailings/Discharge Characterization* section, below.

---

<sup>45</sup> Pyrohydrolysis was not part of the pilot plant scope during this phase of testing.

### *Pilot-Scale Hydrometallurgical Processing Testing*

After completion of the bench-scale testing program a small and a large pilot-scale program was conducted at PRO to confirm bench-scale results, determine larger-scale kinetics and scale-up factors, and to produce bulk iron and titanium pregnant strips for end-product development research.

#### Small Pilot-Scale Hydrometallurgical Testing

The equipment and materials of construction for the small pilot-scale circuit can be found in Appendix 10.

#### *Small Pilot-Scale Leaching and Filtering*

Two leaches were completed using parameters during the bench-scale testing which produced approximately 700 L of PLS for the small pilot-scale operation of the solvent extraction circuits. Leach efficiencies are presented in Table 10.

**Table 10: Small Pilot-Scale Plant Leach Efficiencies**

Test #	Leach Efficiency (%)	
	Fe	Ti
1	81.0	79.5
2	80.5	79.2

Once the leach was complete, the slurry was filtered using a plate and frame filter press. The filtered PLS was pumped into the oxidation columns for the conversion of  $\text{Fe}^{2+}$  to  $\text{Fe}^{3+}$ . The gas flowrate was set to appropriate conditions and oxidation was conducted for approximately 50 hours for complete oxidation to take place. Following the oxidation step, the solution was pumped out of the columns through a polishing filter in preparation for the solvent extraction stage.<sup>46</sup>

#### *Small Pilot-Scale Iron Solvent Extraction*

The iron solvent extraction circuit was configured based on the isotherms prepared during the bench-scale test program. The circuit was initiated with the same number of stages as displayed in Table 11. The circuit operated for 141.2 hours using the PLS produced from the small pilot-scale leaching and the organic composition from the bench-scale program. Initial operating conditions are presented in Table 12.

**Table 11: Initial Small Pilot-Scale Iron Circuit Stage Configuration**

Section	# of Stages
Extraction	5
Scrubbing	1
Stripping	7

<sup>46</sup> A 1 $\mu\text{m}$  cartridge filter was used for this application.

**Table 12: Initial Small Pilot-Scale Iron Circuit Operating Conditions**

Stream	Flowrate (ml/min)	O:A
Organic	100	-
Feed	100	1:1
Scrub Feed	10	10:1
Strip Feed	30	3:1

After the circuit had operated for 140 hours a full profile sample set was taken to determine the concentration of iron across the circuit. These results are displayed in Figure 17. Based on the results of the full profile it was determined that only four stages of extraction would be required in subsequent pilot plant testing.

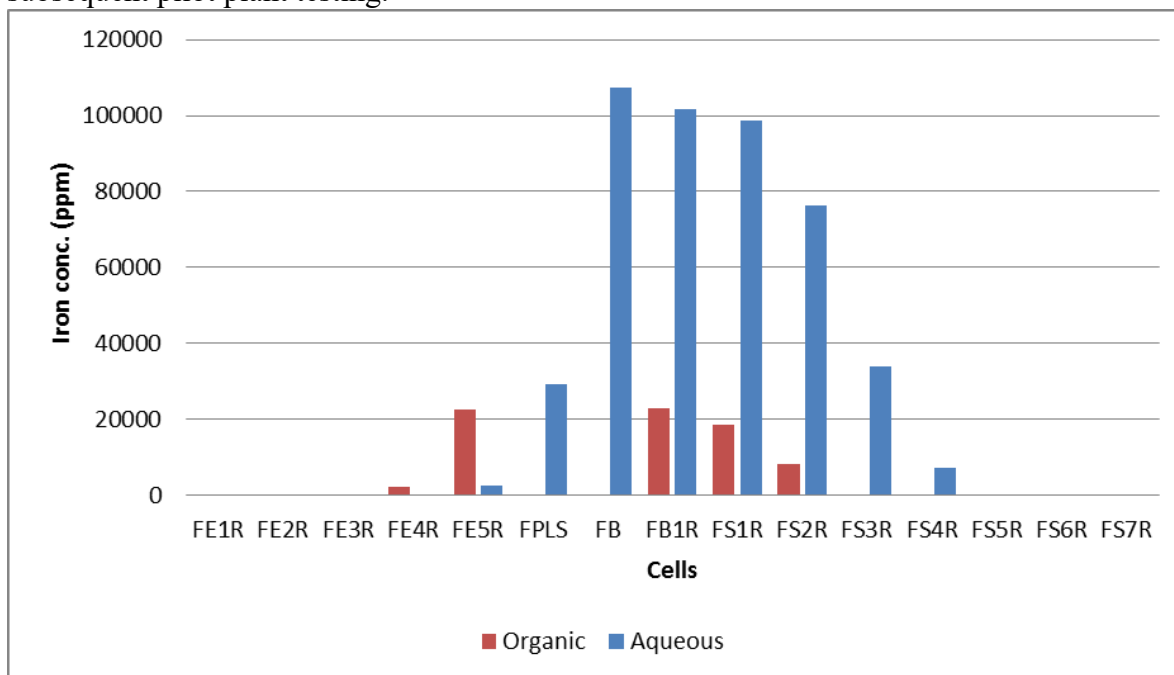

**Figure 17: Small Pilot-Scale Iron Circuit Profile**

The small pilot-scale trials successfully demonstrated the chemistry determined during bench scale testing and the final O:A ratios are displayed in Figure 17. The assay results from the pilot samples are compiled in Appendix 11.

**Table 13: Final Iron Circuit Operating Conditions**

Stream	Flowrate (ml/min)	O:A
Organic	100	-
Feed	65	1.5:1
Scrub Feed	6.5	15:1
Strip Feed	18	5.5:1

*Small Pilot-Scale Titanium Solvent Extraction*

The titanium circuit was configured based on the isotherms prepared during the bench-scale testing. The circuit started with the number of stages displayed in Table 14. The circuit operated for 80.6 hours using the raffinate produced from the small pilot-scale iron circuit and the organic composition from the bench-scale program. Initial operating conditions are presented in Table 15.

**Table 14: Initial Small Pilot-Scale Titanium Circuit Stage Configuration**

Section	# of Stages
Extraction	4
Scrubbing	2
Stripping	8

**Table 15: Initial Titanium Circuit Operating Conditions**

Stream	Flowrate (ml/min)	O:A
Organic	100	-
Feed	35	2.8:1
Scrub Feed	10	10:1
Strip Feed	20	5:1

The final operating conditions for the small pilot-scale titanium circuit are displayed in Table 16. The assay results from the pilot samples are compiled in Appendix 11.

**Table 16: Final Titanium Circuit Operating Conditions**

Stream	Flowrate (ml/min)	O:A
Organic	75	-
Feed	28	2.8:1
Scrub Feed	7.5	10:1
Strip Feed	15	5:1

With titanium extraction efficiencies greater than 99.6%, the small pilot-scale trials successfully demonstrated the chemistry determined during bench-scale testing. The organic-to-aqueous ratios and staging were translated to the pilot plant for further testing.

Large Pilot-Scale Hydrometallurgical Testing

After completion of the small pilot-scale testing program, a large pilot-scale program was conducted at PRO to confirm bench-scale results, determine larger-scale kinetics and scale-up factors, and to produce bulk iron and titanium pregnant strips for end-product development research. The equipment and materials of construction for the large pilot-scale circuit can be found in Appendix 12.

*Large Pilot-Scale Leaching and Filtering*

A total of seven leaches were completed resulting in approximately 2,450 L of PLS to be processed in the iron and titanium solvent extraction circuits. The leaching parameters used in

the large pilot-scale plant were also the same as in the small pilot-scale testing. Results of the leaches are displayed in Table 17.

**Table 17: Large Pilot-Scale Leach Efficiencies**

Test #	Leach Efficiency (%)	
	Fe	Ti
1	86.31	85.16
2	84.24	83.50
3	79.94	77.96
4	79.66	75.75
5	83.84	80.40
6	81.00	77.25
7	83.58	84.14
<b>Average</b>	<b>82.65</b>	<b>80.59</b>

The results showed an average iron leach efficiency of 82.7% and a titanium leach efficiency of 80.6%. It was initially hypothesized that the grind size of the bulk material was incorrect but a screen analysis of the material determined it was within the proper parameters, P80 37 micron (400 mesh). It was later found that the low leach efficiency was due to the solution density being greater than the target of 10% solids. For the final leach, kinetic data was collected to compare if the bulk leach performed at a similar rate to the bench scale leaching. Results of the kinetic data are presented in Figure 18.

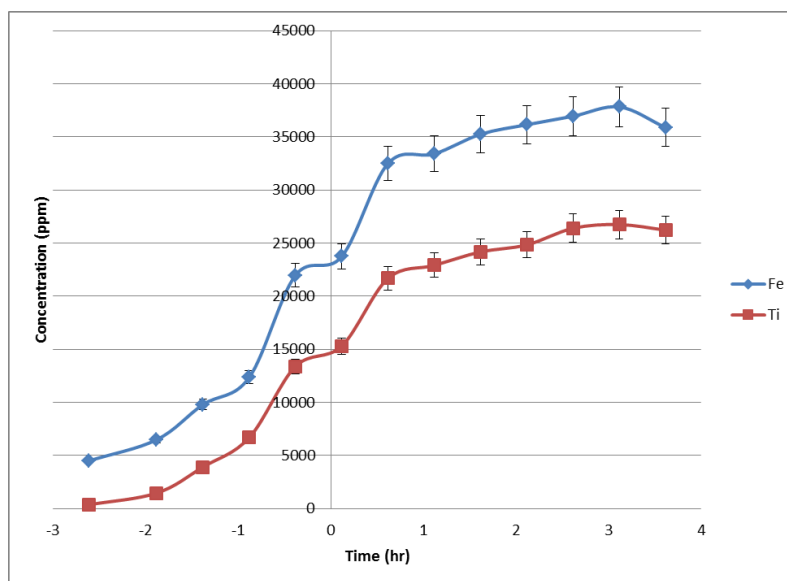

**Figure 18: Large Pilot-Scale Leach Kinetic Data**

In the large pilot-scale plant, an extended amount of time (approximately three hours) was required to heat the leaching tank. In Figure 18, time 0 is when the leaching reached the target operating conditions. When the heating time is not considered and compared to the bench-scale leaching, it can be observed that the bench scale and large pilot-scale leaching trended in a similar manner, as displayed in Figure 19.

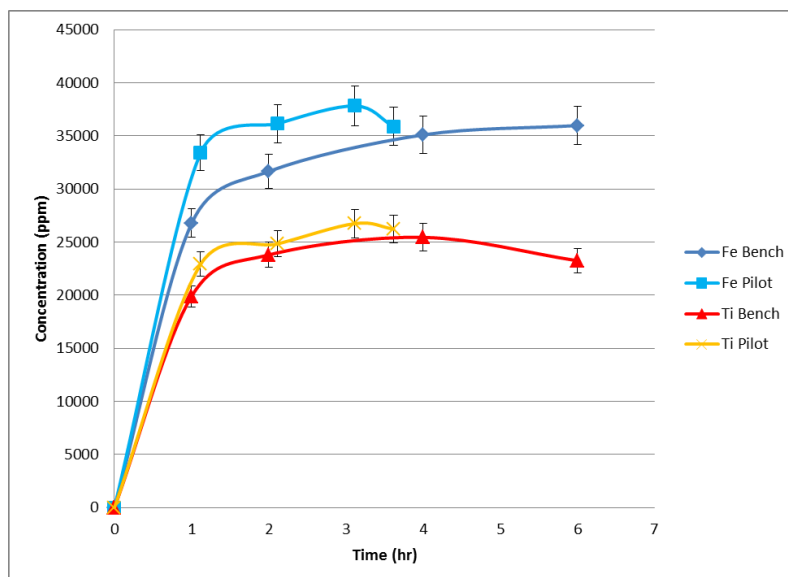

Figure 19: Bench- and Pilot-Scale Leaching Comparison

Filtration of the slurry was completed using the same procedure as was performed in the small pilot-scale plant operations. On average 28.1% of the leach feed mass reported to solid waste (filter cake) stream during filtering at a moisture content of 25%. This equates to approximately 12.8% of the total mass from crude ore.

#### *Large Pilot-Scale Oxidation*

The oxidation was completed using the same oxidation columns and the same procedure as in the small pilot-scale plant operation. Results from the oxidation columns were similar to results obtained during small pilot-scale operation; approximately 50 hours of oxidation were required for the conversion of  $\text{Fe}^{2+}$  to  $\text{Fe}^{3+}$  prior to the solvent extraction circuits. Kinetic data was collected from the oxidation columns and is displayed in Figure 20. Pressure versus oxidation testing showed that increasing past the target of 62.1 kPa (9 psi) did not have a large improvement in the rate of oxidation.

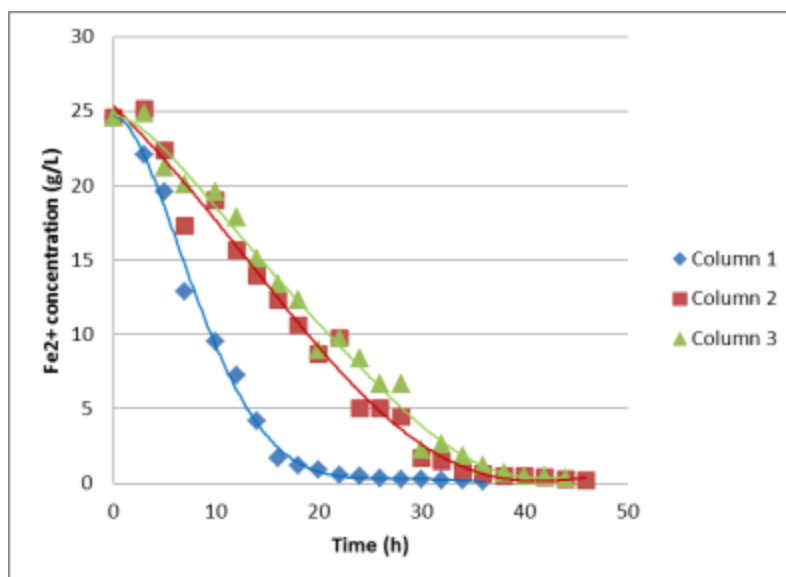
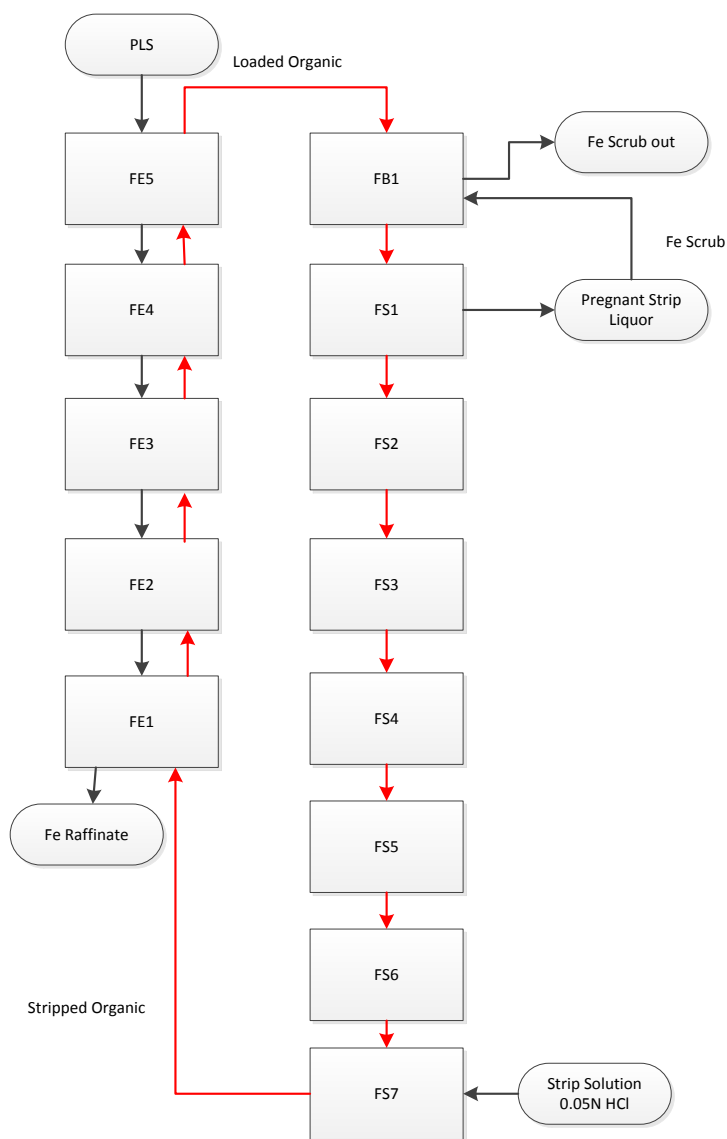

Figure 20: Large Pilot-Plant Kinetic Data

Following the oxidation step the solution was pumped out of the columns and through a 1  $\mu\text{m}$  cartridge polishing filter in preparation for the solvent extraction stage.

#### *Large Pilot-Scale Iron Solvent Extraction*

The large pilot-scale iron extraction circuit used the same configuration and organic-to-aqueous ratios as the small pilot-scale plant previously shown in Table 14 and Table 16. The circuit operated for 133 hours using the PLS provided from the large pilot-scale leaching process. The process flowsheet is presented in Figure 21. The black arrows indicate aqueous flow through the circuit and the red arrows indicate organic flow through the circuit. The “FE” blocks represent the iron extraction stages; the “FB” block represents the iron scrubbing stage; and the “FS” blocks represent the iron stripping stages.



**Figure 21: Iron Solvent Extraction Process Flowsheet**

During the operation of the circuit stable emulsion was observed in the extraction section, particularly in the E1 and E5 stages. E1 is the stage that the organic enters the circuit and the raffinate leaves the circuit whereas the E5 stage is where the PLS enters the circuit and the organic proceeds to the scrubbing section. It was determined that extraction of the iron was complete by stage E2 and so the E1 stage was removed. Phase disengagement testing was conducted on the organic used in the circuit to provide data for potential future scale-up of the iron extraction circuit. Results from the testing are displayed in Figure 22.

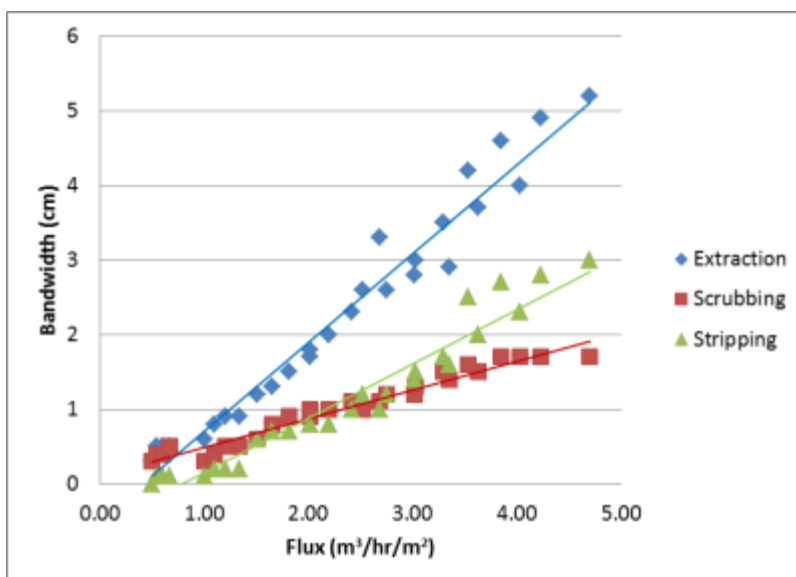

Figure 22: Iron Circuit Phase Disengagement

Kinetic testing of the extraction and stripping of iron was also tested to determine operating parameters for large scale operation; the results are presented in Figure 23. The results show that at least three minutes of mixing are required for proper mass transfer to occur.

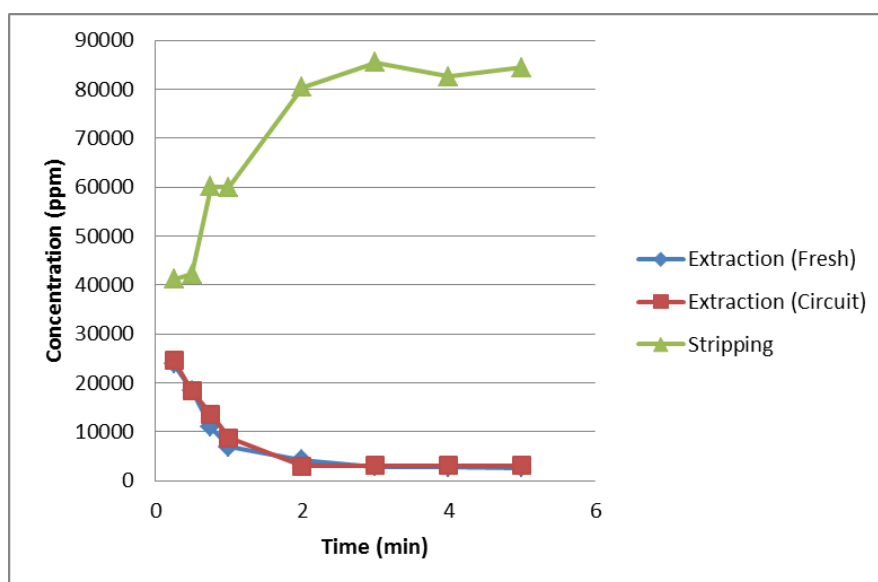

Figure 23: Iron Solvent Extraction Kinetic Results

Raffinate quality was maintained throughout operation of the iron extraction circuit providing feed solution for the titanium extraction circuit. The concentration of the strip solution had higher variability towards the beginning of the pilot testing because the scrub solution used in the process was a made up of the strip solution being generated. The strip solution concentration is presented in Figure 24. It can be observed that the strip solution result begins to converge in the latter part of operation. It was also determined that the low points at hours 30 and 105 were caused by improper strip feed flowrates which were then corrected. The strip solution produced from the iron circuit will be precipitated as iron oxide using a hydrolysis technique from which the HCl can be recovered and recycled back into the process.

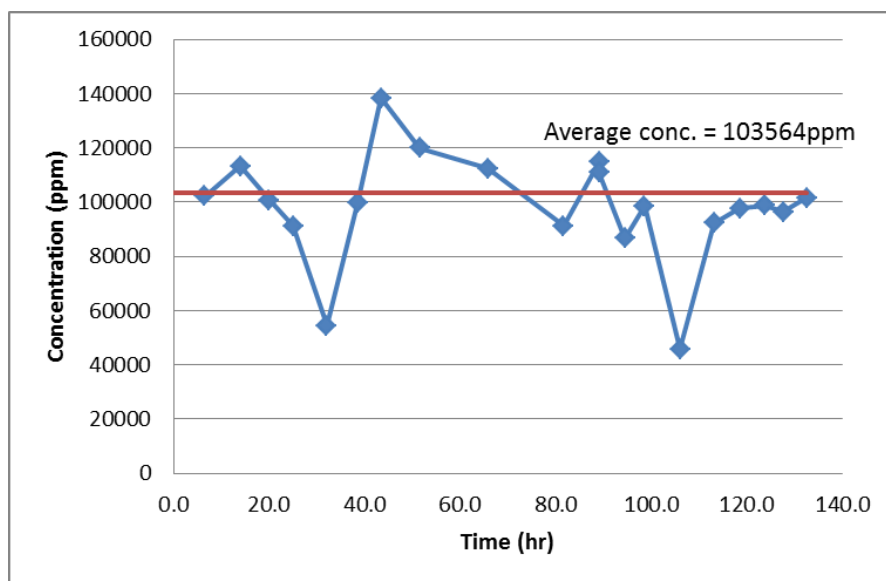

Figure 24: Iron Strip Solution Concentration

Near the end of the large pilot-scale testing a full profile sample set was taken of the circuit to demonstrate the trends of the iron loading and stripping in the circuit. The full profile is presented in Figure 25. The full profile demonstrates that the circuit is properly loading the iron as well as stripping it from the organic. Large pilot-scale plant assay results are compiled in Appendix 13.

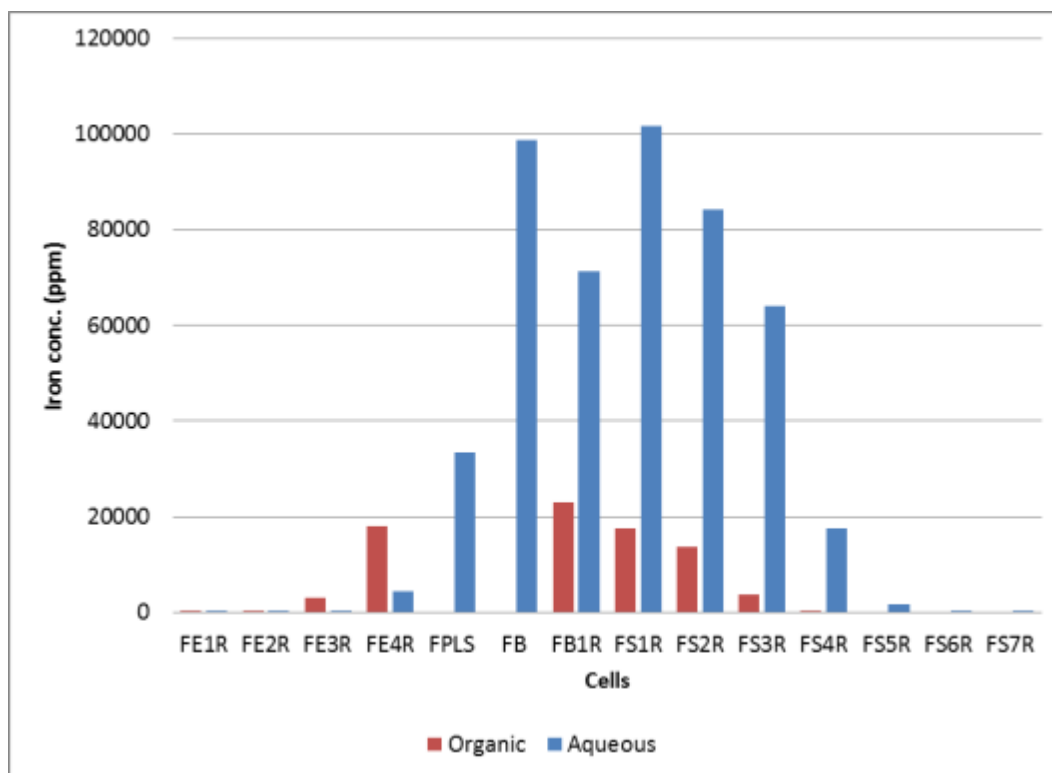

Figure 25: Iron Circuit Full Profile

Upon completion of operation the extraction efficiency of the iron from the PLS was 99.9% while the stripping efficiency was also 99.9%. The extraction process generated a titanium feed solution with <5 ppm iron while the product stripping solution contained on average 103 g/L iron.

### Large Pilot-Scale Titanium Solvent Extraction

The titanium extraction circuit used the same configuration and organic-to-aqueous ratios as the small pilot-scale plant previously shown in Table 14 and Table 16. The circuit operated for 163 hours using the raffinate produced from the large pilot-scale iron extraction circuit. The process flowsheet is presented in Figure 26. The black arrows indicate aqueous flow through the circuit and the red arrows indicate organic flow through the circuit. The “TE” blocks represent the titanium extraction stages; the “TB” blocks represent the titanium scrubbing stages; and the “TS” blocks represent the titanium stripping stages.

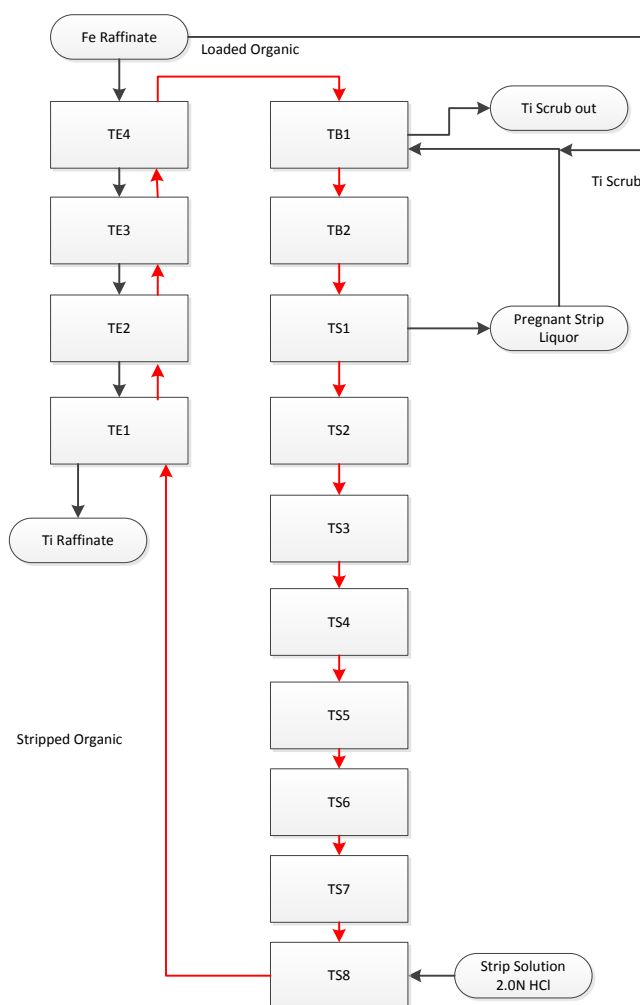

Figure 26: Titanium Solvent Extraction Process Flowsheet

Extraction of the titanium from the solution reached equilibrium within six hours of operation. The titanium concentration in the raffinate was below the average concentration during operation. The average feed and raffinate concentrations are presented in Table 18 whereas the raffinate quality over running time is presented in Figure 27. The concentration in the raffinate

increased near 90 hours of operation. It was determined that the operating temperature in the extraction section was lower than the target temperature, thereby creating a negative effect on the kinetic of extraction. Average titanium raffinate showed vanadium, magnesium, chrome, and manganese concentrations of 144 ppm, 64,294 ppm, 49 ppm, and 240 ppm, respectively. This could be investigated further to determine if extraction of these elements is technically and economically feasible.

**Table 18: Average Titanium Feed and Raffinate Concentrations**

Stream	Assay (ppm)					
	Fe	Ti	V	Cr	Mg	Mn
Feed	14	27184	189	51	65227	312
Raffinate	10	83	144	49	64294	240

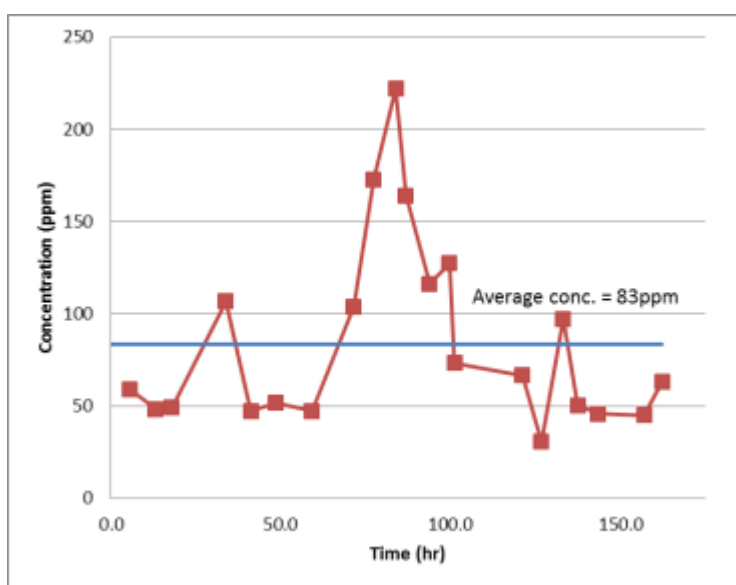

**Figure 27: Large Pilot-Scale Titanium Raffinate Quality**

A large focus of the titanium extraction circuit was on the scrubbing stage, specifically the phase disengagement of the organic and aqueous. The phase disengagement was monitored using two methods. The first method was the analysis of the strip solution by observing an impurity entrainment, such as magnesium, of aqueous in the organic phase. The second method was to take a sample of the organic from the settler to the stripping section and place it in a centrifuge to conduct a visual inspection of the sample. This method could also determine if there was aqueous entrained in the organic phase.

The strip solution quality over the course of operation is presented in Figure 28. The magnesium concentration dropped significantly during the first 25 hours of operation but began to stabilize at higher concentrations than in the small pilot-scale plant operation. To improve the phase disengagement an extra settler was added after the second scrubbing cell immediately before the stripping section. The strip solution collected after 100 hours of operation was used to produce the  $\text{TiO}_2$  during the precipitation stage.

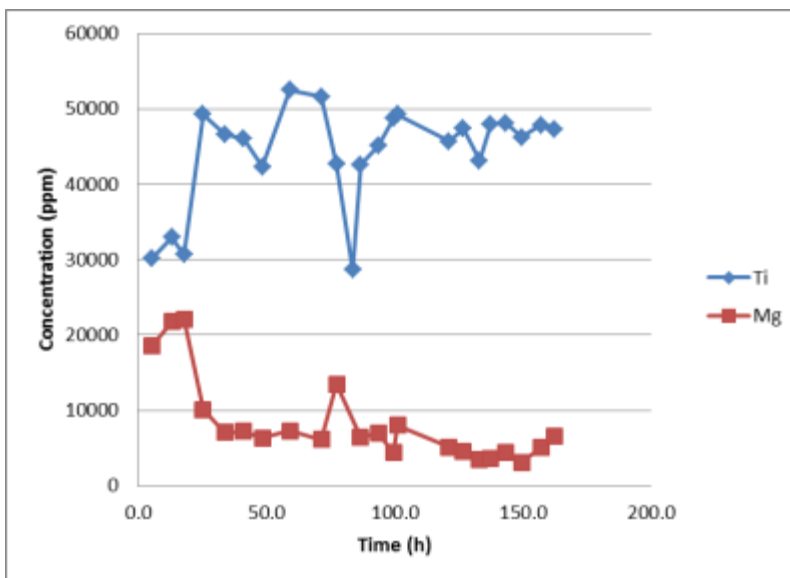

Figure 28: Titanium Extraction Circuit Strip Solution Quality

Phase disengagement testing was conducted on the organic used in the circuit to provide data for potential future scale-up of the titanium extraction circuit. Results from the testing are displayed in Figure 29. As expected from the pilot-scale testing, the required settling area is significantly greater for the scrubbing section than the extraction and stripping sections.

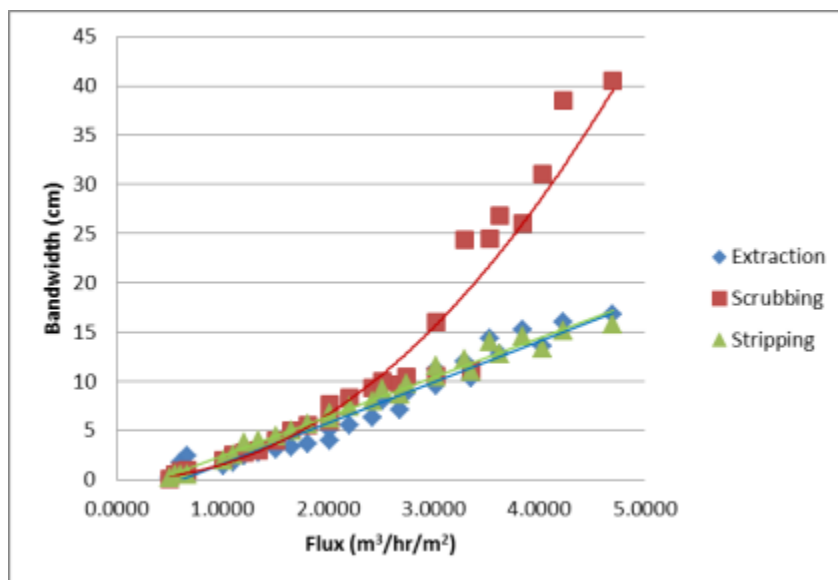

Figure 29: Titanium Circuit Phase Disengagement

Kinetic testing was also conducted on the titanium extraction organic. The results are presented in Figure 30. The results show that while three minutes are required for extraction at least four minutes are required for proper mass transfer to occur.

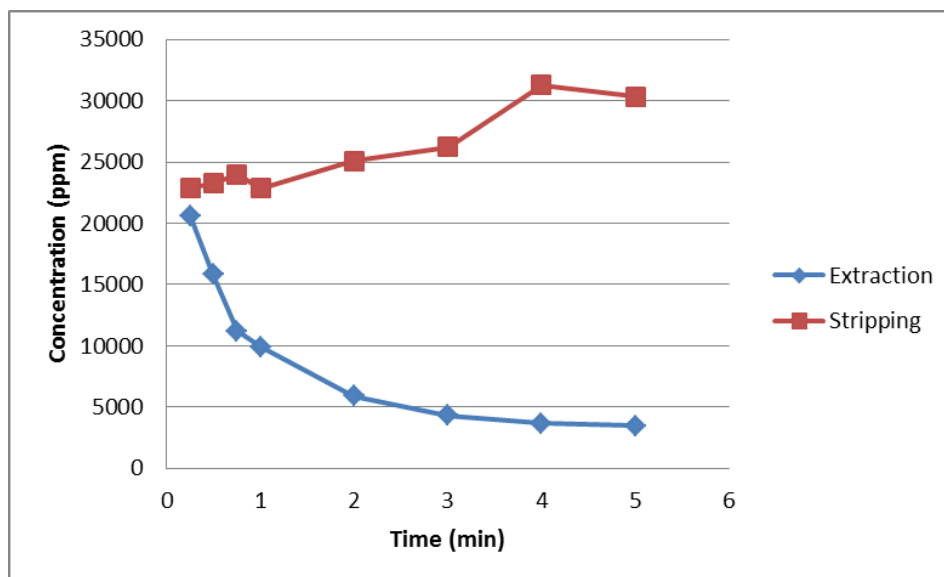

Figure 30: Titanium Solvent Extraction Kinetic Results

Upon completion of the pilot plant operation, the extraction efficiency of the titanium from the PLS was 99.7% and the stripping efficiency was 99.8%. The extraction process generated a raffinate for magnesium recovery containing an average of 83 ppm Ti while the stripping solution for  $\text{TiO}_2$  precipitation contained, on average, 45 g/L Ti. A full profile sample set was not taken during small pilot-scale plant operation but instead was completed in the large pilot-scale plant to demonstrate the trends of the titanium loading and stripping in the circuit. The full profile is presented in Figure 31. The full profile demonstrates that the circuit is properly loading the titanium as well as stripping it from the organic. The large pilot-scale assay results are compiled in Appendix 13.

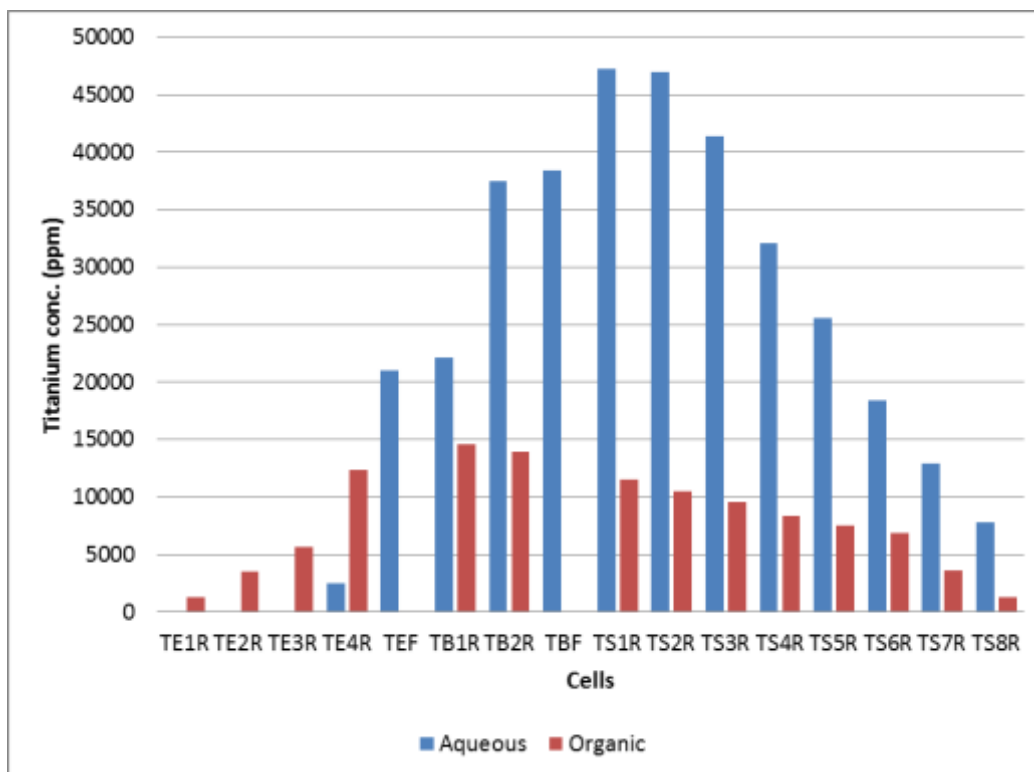

Figure 31: Titanium Circuit Full Profile

### *Product Development*

The iron and titanium pregnant strip solutions from the large pilot-scale plant were used to produce iron oxide and titanium dioxide powder products. These tests were conducted to determine technical feasibility of producing these potential products for market evaluation. The results below are used for initial proof of concept but not necessarily the “best case” product quality that can be realized from this technology.

#### Iron Oxide Production

For the production of  $TiO_2$  in the CTL process the removal of iron prior to titanium solvent extraction is required. The iron strip solution generated from the iron solvent extraction circuit is of a high quality which can be used to produce high quality iron products. The iron is precipitated from the solution to produce an iron oxy-hydroxide ( $FeOOH$ ) which was confirmed by X-ray diffraction (XRD) analysis, presented in Figure 32.

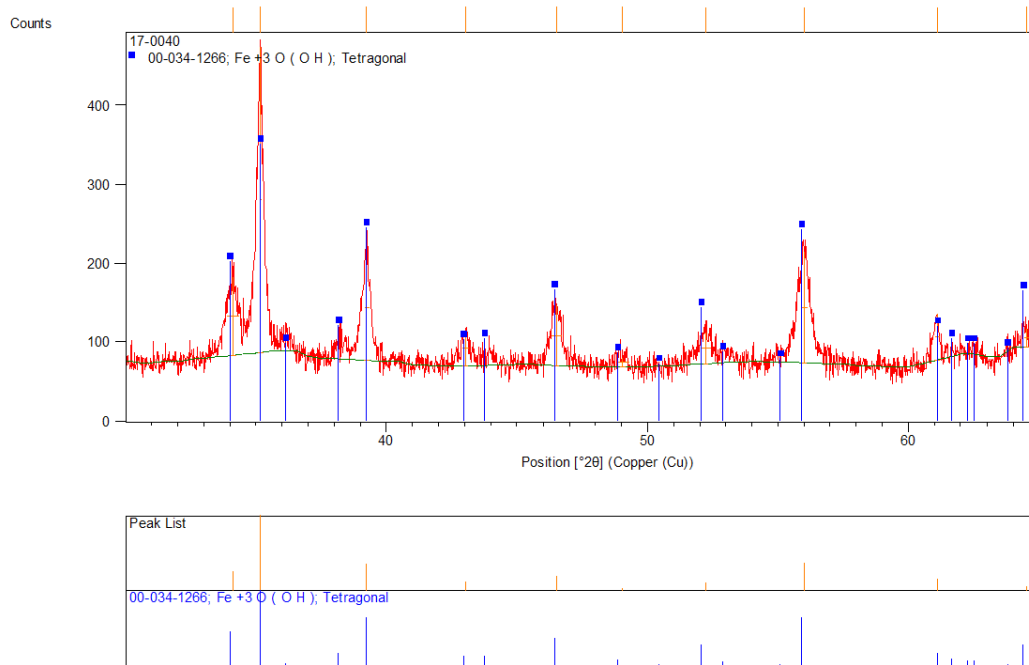

Figure 32: Iron Strip Solution Precipitate XRD Pattern

The precipitate was calcined at 650°C to produce a ferric oxide ( $\text{Fe}_2\text{O}_3$ ) product which could potentially be used for applications such as iron pigments. Once again, confirmation of the product was completed using XRD, as displayed in Figure 33. Chemical analysis of the calcined product is presented in Table 19.

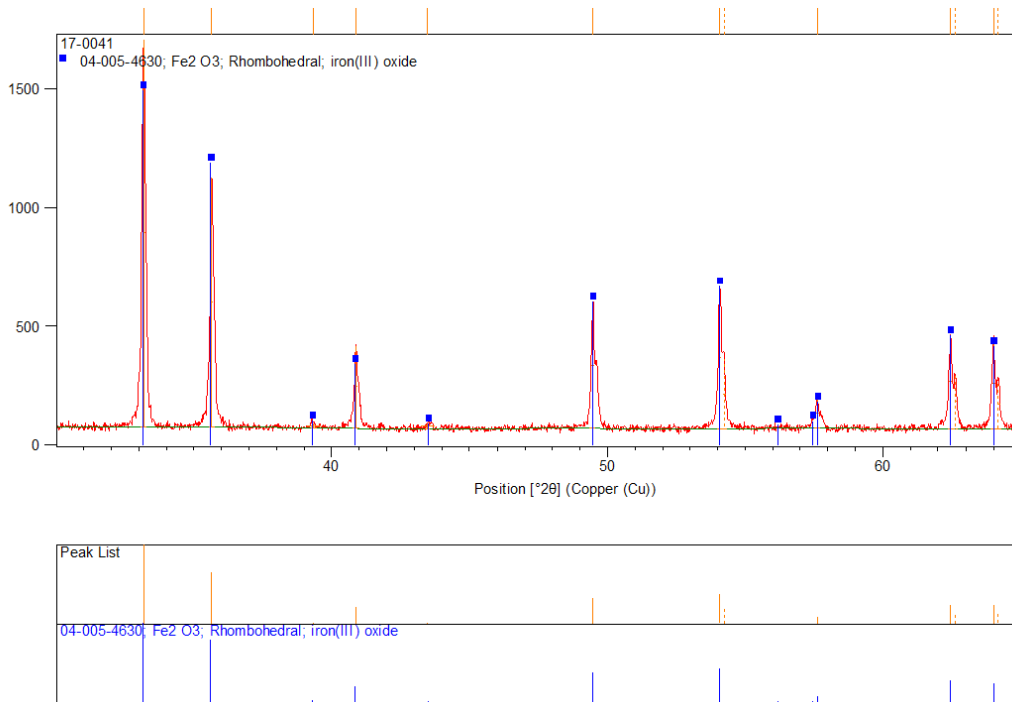

Figure 33: Calcined Iron Precipitate XRD Pattern

**Table 19: Fe<sub>2</sub>O<sub>3</sub> Powder Purity**

Assay (%)				
Fe	Ti	Mg	Ca	Al
68.9	0.85	*	*	*

\*Below detection limit

The results of the chemical analysis demonstrated an iron oxide powder with a purity level of 98.5% Fe<sub>2</sub>O<sub>3</sub>. The majority of contamination in the iron oxide powder was caused by entrained titanium in the strip solution, which averaged approximately 700 ppm in the pilot testing. This contamination was due to poor phase disengagement in the solvent extraction process which led to increased concentrations of titanium in the scrub solution. The settling time in the scrubbing circuit was increased which ultimately demonstrated improved strip solution quality, but optimization testing may result in a reduction of titanium in the iron strip solution.

### Titanium Dioxide Production

Following the solvent extraction separation processes, the titanium-rich pregnant strip liquor was subjected to thermal precipitation. Following precipitation and filtration, the precipitate is dried and calcined to produce a TiO<sub>2</sub> powder product. The objective of these trials was to produce a TiO<sub>2</sub> powder and provide characterization including purity (chemical assay), whiteness and brightness, and particle size. A summary of the required steps for production of TiO<sub>2</sub> powder were:

1. Feed preparation: removal of organic and suspended solids,
2. Precipitation: thermal precipitation with 2% nuclei, and
3. Filtration, drying, and calcining: filtering, acid washing, removal of impurities, refiltering and repulping with water, addition of calcining additives (potassium carbonate and aluminum hydroxide), and calcining.

With the proper precipitation and calcining conditions the desired product can be produced. In this case, the target product is crystalline rutile. The process flowsheet for precipitation is presented in Figure 34.

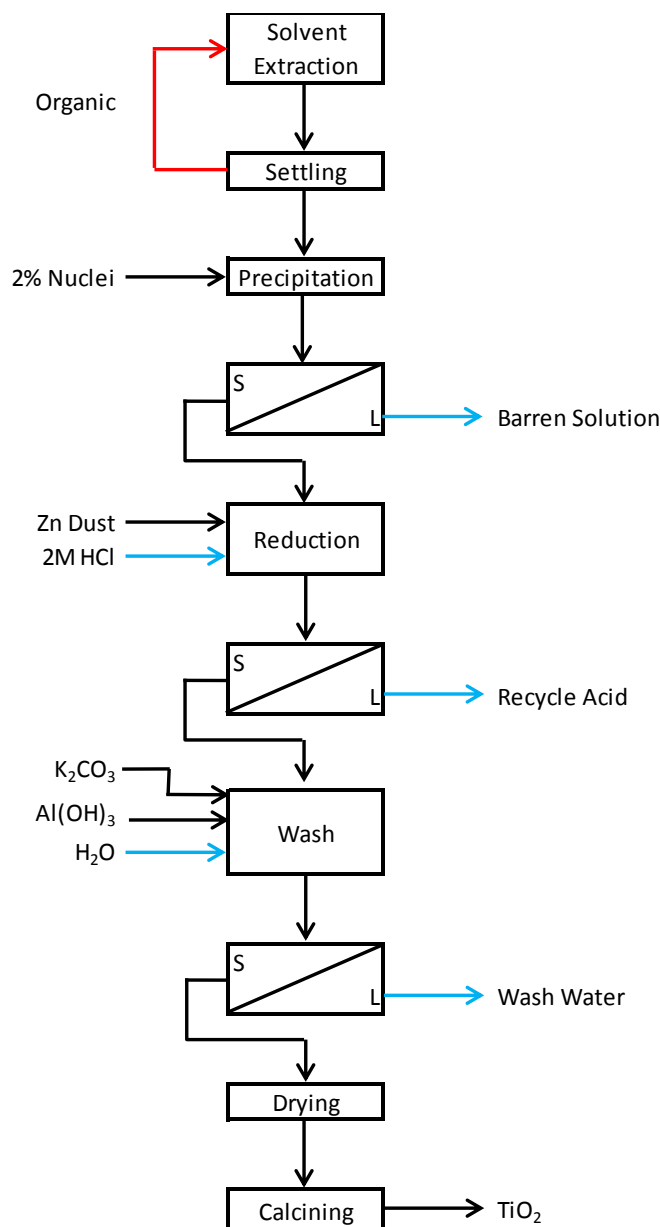

Figure 34: TiO<sub>2</sub> Precipitation Flowsheet

The purity of the strip solution and the precipitation process ultimately determines the product purity generated from the process. Table 20 compares the chemical analysis of two powder samples produced in the testing compared to a standard commercially available DuPont™ Ti-Pure® R350<sup>47</sup> TiO<sub>2</sub> powder. The normalized purity levels for the DuPont™ Ti-Pure® R350, NRRI/PRO Test 15, and NRRI/PRO Test 18 were calculated to be 96.5%, 99.3%, and 99.3% TiO<sub>2</sub>, respectively. The full chemical analysis by AGAT can be found in Appendix 14.

<sup>47</sup> Designed for use in plastic applications. For more information see the following site: [https://www.chemours.com/Titanium\\_Technologies/en\\_US/products/350/](https://www.chemours.com/Titanium_Technologies/en_US/products/350/)

Table 20: TiO<sub>2</sub> Product Purity Comparison

Sample Description	Al	Ba	Ca	Co	Cs	Ga	Nb	P	Rb	Si	Ta	Ti	V	Zn
	%	ppm	%	ppm	ppm	ppm	ppm	%	ppm	%	ppm	%	ppm	ppm
DuPont™ Ti-Pure® R350	0.82	<0.5	0.09	<0.5	44.6	0.82	1	0.06	0.6	0.86	1.9	58.7	<5	<5
PRO Test #15 Product	0.12	17.2	0.08	0.8	<0.1	0.15	106	0.3	<0.2	0.01	7.4	59.3	23	15
PRO Test #18 Product	0.12	22.1	0.07	0.6	<0.1	0.17	117	0.3	<0.2	0.02	6.5	59.6	17	22

Based on solution analysis, the precipitation process recovers approximately 99% of the titanium to produce the TiO<sub>2</sub> powder. The niobium results in the product produced by PRO are greater than the R350 product. Since niobium is not carcinogenic or toxic in low doses it should not diminish potential market uses (food, cosmetic, pharmaceutical). Product standards for food, cosmetic, and pharmaceutical grade TiO<sub>2</sub> is presented in Table 21. The product could also be used for pigment grade material as long as the niobium does not affect the whiteness and brightness.

Table 21: TiO<sub>2</sub> Product Standards

Item	PRO Product	US Product	European & Japanese Product
Characteristics	White powder	white powder	white powder
Surface Treatment	None	None	None
Loss on drying	≤ 0.5%	0.5% max	-----
Loss on ignition	≤ 0.5%	0.5% max	-----
Water-Soluble substance	0.12% Max	0.25% max	0.5% max
Acid Soluble substance	0.05% Max	0.5% max	-----
Arsenic	≤ 0.1 ppm	1 ppm max	5 ppm max
Lead	≤ 1 ppm	10 ppm max	20 ppm max
Antimony	≤ 0.5 ppm	2 ppm max	100 ppm max
Mercury	≤ 0.1 ppm	1 ppm max	-----
Iron	≤ 1 ppm	-----	200 ppm max
Assay	99.3	99.0~100.5%	98.0~100.5%

Figure 34 shows the multiple stages of filtration during which losses occur due to the very small particle size of the TiO<sub>2</sub> of approximately 400 nm (discussed below). From precipitation through the washing process, approximately 80% of the TiO<sub>2</sub> is recovered; however, an optimized filtration process may result in higher TiO<sub>2</sub> recovery.

#### *Size Reduction (Jet Milling)*

Titanium dioxide powder size reduction was conducted via jet milling. Adjusting the particle size influences the optical properties of the material. Jet mill processing of test samples was performed using a Fluid Energy Model 4 Micro-Jet mill fitted with alumina and tungsten carbide

liners. Particle size and morphology was characterized using a Horiba Partica LA-950 with the particles suspended in an aqueous solution. Samples were analyzed before and after jet milling and compared to a commercial DuPont™ Ti-Pure® R350. A summary of these results can be found in Table 22, below. In this table the “TP #15 Calcined” and “TP #18 Calcined” refer to the NRRI/PRO calcined test products as-is, while the “TP #15 Jet” and “TP #18 Jet” refer to the same NRRI/PRO test products that were size reduced via jet milling.

**Table 22: TiO<sub>2</sub> Powder Particle Size Analysis**

Sample	DuPont™ Ti-Pure® R350		TP #15 Calcined		TP #15 Jet		TP #18 Calcined		TP #18 Jet	
		μm		μm		μm		μm		μm
Median Size	0.31254	μm	0.35344	μm	0.18317	μm	0.43983	μm	0.34529	μm
Mean Size	0.30938	μm	0.38915	μm	0.19288	μm	0.60808	μm	0.3668	μm
Variance	3.86E <sup>-03</sup>	μm <sup>2</sup>	1.58E <sup>-01</sup>	μm <sup>2</sup>	5.01E <sup>-03</sup>	μm <sup>2</sup>	5.44E <sup>-01</sup>	μm <sup>2</sup>	9.94E <sup>-02</sup>	μm <sup>2</sup>
Std.Dev.	0.0621	μm	0.3979	μm	0.0708	μm	0.7376	μm	0.3153	μm
Mode Size	0.3204	μm	0.3642	μm	0.1848	μm	0.4187	μm	0.3618	μm
Geo.Mean Size	0.3025	μm	0.3474	μm	0.1806	μm	0.4718	μm	0.336	μm
Geo.Variance	1.0213	μm <sup>2</sup>	1.0642	μm <sup>2</sup>	1.0603	μm <sup>2</sup>	1.1664	μm <sup>2</sup>	1.0539	μm <sup>2</sup>

A plot comparing the particle size distribution of NRRI/PRO TiO<sub>2</sub> products #15 and #18 is found in Figure 35.

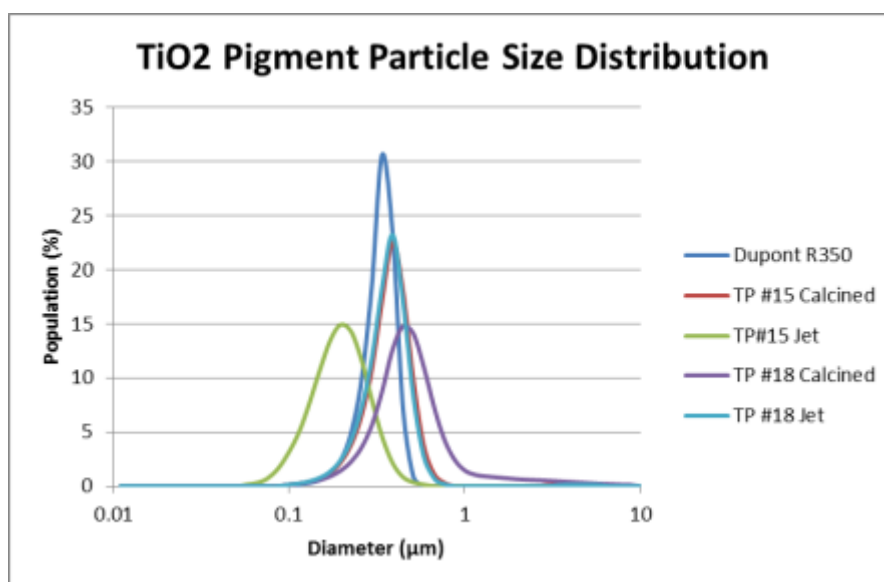

**Figure 35: TiO<sub>2</sub> Powder Particle Size Distribution**

#### *Whiteness and Brightness Characterization*

The color rating used throughout this project was the CIE L\*a\*b\* System. This system is an international standard which was designed to approximate human vision. There are three components to this system, L\*, a\*, and b\*. L\* represents lightness ranging from 0 to 100 where 0 is dark and 100 is light. The a\* represent +red/-green, meaning positive values are more red while negative values are more green. The b\* is similar in that it represents +yellow/-blue, meaning positive values are more yellow while negative values are more blue. Due to the white nature of pure TiO<sub>2</sub> product it is difficult to visibly see the differences in the a\* and b\* values. The pigment color and light scattering properties were characterized using a BYK-Gardener

“spectro-guide sphere gloss” spectrophotometer. Samples were measured by placing the instrument on the surface of a polypropylene sample bag containing the powdered material and taking a three measurement mean at three different locations. The instrument employs D65/10° measurement geometry.<sup>48</sup>

A plot of the spectral response of TiO<sub>2</sub> products #15 and #18 relative to commercial DuPont™ Ti-Pure® R350 can be found in Figure 36. A summary of the whiteness and brightness properties of these samples can be found in Table 23. Further comparison of CIE L\*a\*b\* results are presented in Figure 37.

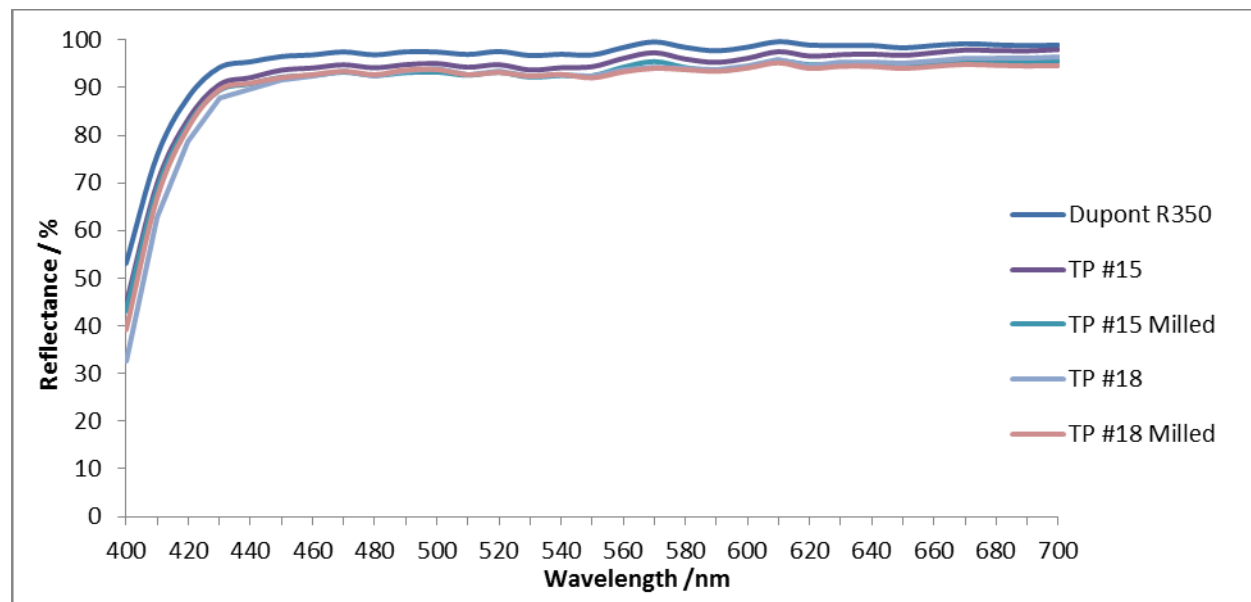

Figure 36: Pigment Spectral Response

Table 23: CIE L\* a\* b\* Measurements

Sample:	L*	a*	b*	G	dL*	da*	db*	dE*	dG
DuPont™ Ti-Pure® R350	99.15	-0.2	1.99	22.5	2.8	0.51	1.51	3.22	22.5
TP #15	98.15	-0.15	2.5	11.5	1.81	0.57	2.02	2.77	11.5
TP #15 Milled	97.45	-0.18	2.31	10.4	1.1	0.54	1.82	2.19	10.4
TP #18	97.42	-0.56	2.98	13.9	1.08	0.16	2.49	2.71	13.9
TP #18 Milled	97.34	-0.45	2.13	9.4	1	0.27	1.64	1.93	9.4

<sup>48</sup> For more information on this system, please see: [http://www.byk.com/fileadmin/byk/support/instruments/technical\\_information/datasheets/English/Color/Solid%20Color/Principles\\_of\\_Color\\_Measurement\\_Standard\\_Illuminants\\_and\\_Observer\\_Color\\_Scales\\_and\\_Measurment\\_Geometries.pdf](http://www.byk.com/fileadmin/byk/support/instruments/technical_information/datasheets/English/Color/Solid%20Color/Principles_of_Color_Measurement_Standard_Illuminants_and_Observer_Color_Scales_and_Measurment_Geometries.pdf)

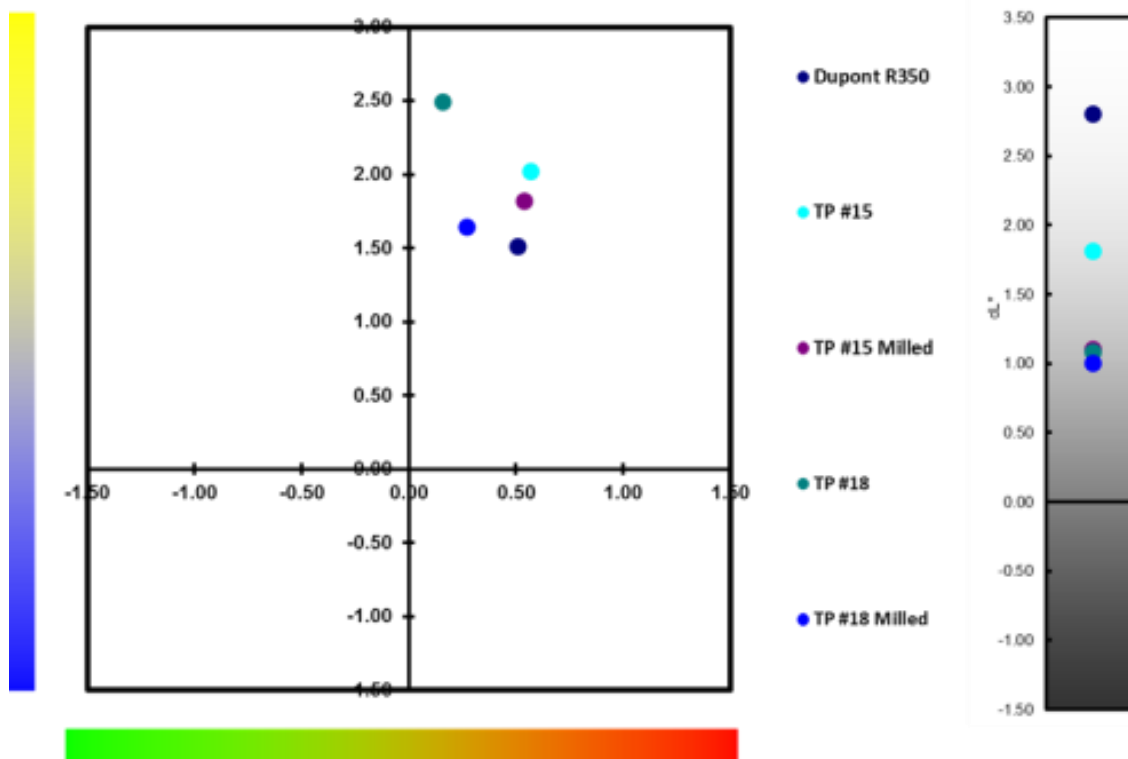

Figure 37: CIE L\* a\* b\* Chart

The NRRI/PRO products #15 and #18 showed lower optical performance than the benchmark R350 product. It is important to note that the NRRI/PRO samples are uncoated whereas DuPont™ Ti-Pure® R350 has undergone a proprietary coating process which specifically influences the reflectance (or gloss) as it reduces agglomeration of the particles. The reflectance is negatively affected by a relatively large amount of hard, unground agglomerates in the samples. The whiteness and brightness of the TiO<sub>2</sub> product is affected by the purity as well as the particle size. Particles should be in the range of 0.1-0.5 μm with particles greater than 5 μm having an effect on dispersibility of the product. Dispersibility is important as agglomerated particles report lower whiteness and brightness values. Testing at PRO was completed on dry uncoated particles which may agglomerate, affecting their whiteness and brightness results. At present PRO does not have a method for coating the TiO<sub>2</sub> product; however, coating of the TiO<sub>2</sub> is expected to improve the optical properties of the product. Product optimization is suggested if this product will be used in the pigment industry to improve the optical properties.

### *Titanium Dioxide Purity Optimization Study*

A titanium dioxide powder purity study was conducted to determine how pure of a product could be generated using the CTL technology. To increase the purity of the titanium dioxide product the surface modifiers were not included in the precipitation process. Table 24 displays the DuPont™ Ti-Pure® R350 vs. the NRRI/PRO products with surface modifiers (products #15 and #18) and without surface modifiers (product #29). Appendix 15 contains the AGAT chemical assay for the NRRI/PRO TiO<sub>2</sub> product #29.

**Table 24: TiO<sub>2</sub> Product Purity Comparison with and without Surface Modifiers**

Sample Description	Al	Ba	Ca	Co	Cs	Ga	Nb	P	Rb	Si	Ta	Ti	V	Zn
	%	ppm	%	ppm	ppm	ppm	ppm	%	ppm	%	ppm	%	ppm	ppm
DuPont™ Ti-Pure® R350	0.82	<0.5	0.09	<0.5	44.6	0.82	1	0.06	0.6	0.86	1.9	58.7	<5	<5
PRO Test #15 Product	0.12	17.2	0.08	0.8	<0.1	0.15	106	0.3	<0.2	0.01	7.4	59.3	23	15
PRO Test #18 Product	0.12	22.1	0.07	0.6	<0.1	0.17	117	0.3	<0.2	0.02	6.5	59.6	17	22
PRO Test #29 Product	<0.01	70.3	<0.05	0.5	<0.1	0.11	101	0.01	<0.2	0.06	3.7	59.9	14	43

As can be seen in Table 24 the NRRI/PRO TiO<sub>2</sub> product #29 was found to contain much lower amount of phosphorus and other impurities, thereby increasing the product purity from approximately 99.3% to 99.8% TiO<sub>2</sub>. The amount of cobalt, gallium, niobium, tantalum, and vanadium slightly decreased, while the amount of barium, silica, and zinc increased in the TiO<sub>2</sub> product #29 product versus the NRRI/PRO samples with the surface modifiers (products #15 and #18).

### *Composite Product Recovery*

An estimated unit throughput table was assembled from the pilot-scale testing results and projected production-scale recoveries for the iron and titanium circuits. These figures would be used for future plant sizing and capital and operating expenditure calculations. These throughput estimates can be found in Table 25 and Table 26, below. Production estimates for iron oxide and titanium dioxide powders were 16.5% and 12.1%, respectively, based upon testing results with the ilmenite testing sample and projected production-scale unit recoveries.

**Table 25: Unit Iron Throughput**

Unit Operation	Unit Throughput
Crude Ore Mined	1.0000
Comminution	1.0000
Beneficiation	1.0000
Concentrate Regrinding	0.4554
Leaching	0.4554
Solvent Extraction	0.1742
Precipitation/Calcination	0.1739
<b>Composite Fe<sub>2</sub>O<sub>3</sub> Product</b>	<b>0.1652</b>

**Table 26: Unit Titanium Throughput**

Unit Operation	Unit Throughput
Crude Ore Mined	1.0000
Comminution	1.0000
Beneficiation	1.0000
Concentrate Regrinding	0.4554
Leaching	0.4554
Solvent Extraction	0.1512
Precipitation/Calcination	0.1509
<b>Composite TiO<sub>2</sub> Product</b>	<b>0.1207</b>

### *Tailings/Discharge Characterization*

The CTL hydrometallurgical process contains discharge streams which require proper disposal. Waste produced includes the tailings from the leaching process, a bleed stream from titanium raffinate recycling, and wash solutions produced from the precipitation process. A blended sample of the leaching tailings (filter cake) was analyzed chemically as well as sent to a third-party lab for comparison with the Ontario regulation 558 standards for metals and inorganic discharge. The leaching tailings chemical analysis can be seen below in Table 27.

**Table 27: Leach Tailings Chemical Analysis**

Assay (%)												
Al	As	Ba	Ca	Cr	Cu	Fe	K	S	Si	Ti	Zn	Zr
0.41	0.003	0.001	0.6	-	0.09	18.98	0.04	0.2	20.54	16.68	0.04	0.01

The results of the metals and inorganic discharge test are shown in Table 28. As seen in Table 28 the solid tailings are lower than the standards of Ontario, but these results should be compared to current Minnesota standards for comparison.

**Table 28: Leach Tailings Environment Testing**  
**Ontario Reg. 558 Metals and Inorganics**

Parameter	Unit	Standard	Result
Arsenic Leachate	mg/L	2.5	<0.010
Barium Leachate	mg/L	100	<0.100
Boron Leachate	mg/L	500	0.261
Cadmium Leachate	mg/L	0.5	<0.010
Chromium Leachate	mg/L	5	0.039
Lead Leachate	mg/L	5	<0.010
Mercury Leachate	mg/L	0.1	<0.01
Selenium Leachate	mg/L	1	<0.010
Silver Leachate	mg/L	5	<0.010
Uranium Leachate	mg/L	10	<0.050
Fluoride Leachate	mg/L	150	0.28
Cyanide Leachate	mg/L	20	<0.05
(Nitrate + Nitrite) as N Leachate	mg/L	1000	<0.70

Although not tested, the following would be envisioned for the remaining streams of the hydrometallurgical process: from the titanium extraction circuit, most of the raffinate is recycled back to the leaching process to recover the magnesium chloride ( $MgCl_2$ ) for the PRO mixed chloride leach process. To control the buildup of impurities a bleed stream is removed from the system. Impurities such as aluminum (Al), chromium (Cr), manganese (Mn), and vanadium (V) are precipitated using magnesium oxide ( $MgO$ ) to produce a mixed hydroxide precipitate. The precipitate is filtered and the precipitate is roasted to form a more stable mixed-oxide solid. Potential added value products from the bleed stream impurities is elaborated in later sections. The filtrate from the precipitation consists mainly of  $MgCl_2$  as well as very small amounts of calcium chloride ( $CaCl_2$ ), potassium chloride (KCl), and sodium chloride (NaCl). A small pyrohydrolysis unit is expected to be used to hydrolyze the solution and produce  $MgO$ , which could be a potential future product, as well as recycle the HCl back into the process. The wash solution generated from the precipitation process contains little in terms of impurities and so treatment would consist of pH adjustment followed by standard industrial water treatment techniques.

### ***Pilot Plant to Production Scale***

To reproduce the closed-loop system of the CTL process, recycling of the titanium raffinate to the leaching process is required. Recycling tests not only demonstrate that impurities do not affect the leaching efficiency, but also help to determine the expected impurity buildup based on the bleed stream volume. Using raffinate produced during the large pilot-scale operation, bench-scale leaching was conducted. The leaching parameters were the same as in the large pilot-scale process. The iron and titanium leach efficiencies from Test #1 were lower than pilot results, as shown in Table 29. It was determined that the free acid of the lixiviant was slightly lower than the target. Therefore, the free acid was adjusted for Test #2 and results captured. Table 29 shows that the Test #2 leaching efficiency was similar to the results during the large pilot-scale

testing program. This small test program found that recycling of the titanium raffinate to leaching is feasible, however this should be further investigated during a continuous large-pilot or demonstration scale testing program.

**Table 29: Raffinate Recycle Leach**

Test #	Leach Efficiency (%)	
	Fe	Ti
1	79.20	77.16
2	83.85	80.14

### ***Beneficiation Circuit By-Product Utilization Testing***

In an effort to find uses for the by-products from the beneficiation process, samples of the high silica tailings and magnetite/titanomagnetite products were subjected to various research programs. Two of the most promising technologies are briefly introduced below.

#### NRRI Road Patch Technology Research

A research project is currently being conducted by Mr. Zanko of NRRI to determine whether the high silica tailings and the magnetite/titanomagnetite products streams from the ilmenite beneficiation process could be used to produce road repair compound components.<sup>49</sup>

Preliminary laboratory testing has shown that both product streams have potential for utility as components of NRRI's patented road patch formulation.

Figure 38 shows that the ilmenite high silica tailings (dashed light line) have a particle size distribution that is similar to the major taconite tailings-derived component (fines) of the current road patch formulation. The size distribution of the magnetite/titanomagnetite (shown as the dashed dark line), approaches that of conventional magnetite concentrates (con), but is still coarser overall.

---

<sup>49</sup> Zanko (2017). Funding support was provided by MnDOT Contract 99008, Work Order 241.

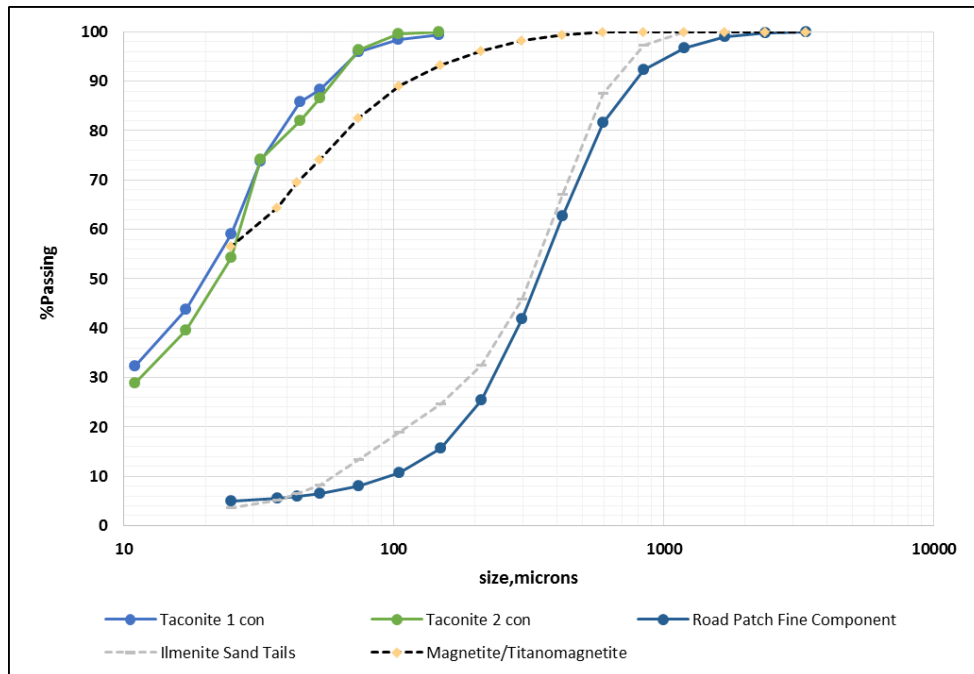

Figure 38: Particle Size Distribution of Potential Road Patch Components

The lab testing compared two patch formulations having the following dry component composition:

**Formulation 1**

- 17g magnetite concentrate
- 70g taconite tailings fines
- 13g coarse taconite tailings

**Formulation 2**

- 17g magnetite concentrate
- 35g taconite tailings fines
- 35g ilmenite sand tailings
- 13g coarse taconite tailings

Formulation 1 was composed of taconite tailings fines (70% by weight), while Formulation 2 included equal percentages of taconite tailings fines (35% by weight) and ilmenite sand tailings (35% by weight). All other aspects of the test were kept the same, including the composition and concentration of the liquid activator, and mixing time. Mr. Zanko found that the Formulation 1 took 75 to 90 minutes to achieve a hard set, whereas Formulation 2 took approximately 30 minutes to achieve a comparably hard set. The accelerated set time of Formulation 2 was due to the ilmenite sand tailings having: 1) a higher MgO content (23% MgO); 2) a higher percentage of reactive magnetic iron (Mag Fe); and 3) a greater reactive surface area, compared to the taconite tailings fines.

Mr. Zanko found the magnetite/titanomagnetite from the ilmenite process also could be similarly used as a partial or complete substitute for the magnetite concentrate component of the road

patch formulation. Ilmenite processing products (magnetite/titanomagnetite and high silica tailing streams) were completely substituted for the magnetite acid concentrate and taconite fines. The tested mix took approximately five minutes longer to achieve a firm set than a taconite-based formulation. The somewhat longer set time was most likely due to the magnetite/titanomagnetite having a lower magnetic iron content (22%, compared to 66% Mag Fe for regular acid concentrate), and an overall coarser particle size distribution (e.g., less surface area per unit weight).

These preliminary findings suggest that ilmenite ore processing by-products have potential for providing an additional value stream for enhancing the overall economics of titanium resource development in Minnesota, and may warrant further investigation.

#### NRRI Nodular Reduced Iron Technology Research

Dr. Anameric of NRRI conducted a study to determine whether nodular iron technology could be used to produce a highly metallized and titanium free nodular iron product from the magnetite/titanomagnetite beneficiation product.<sup>50</sup> The feasibility of nodular iron technology was investigated to recover the iron units contained in the magnetite/titanomagnetite stream. Nodular iron is a highly metallized, impurity free alternative iron unit. Its production is dependent on the reduction of iron oxides and formation of two immiscible liquid phases, metal and slag. The interaction between the impurities contained in the concentrate and flux yields a low melting temperature (fusible) slag. The study focused on determining appropriate fluxes and their addition rates needed for formation of low melting temperature slag.

Throughout the study by Dr. Anameric, raw material mixtures, including the magnetite/titanomagnetite product, coal, and fluxes were heated in an electric resistance furnace. The products were evaluated as either direct reduced iron (DRI) or nodular iron and slag. Nodular iron and slag production was achieved when a raw material mixture containing approximately 60% magnetite/titanomagnetite 10% coal, and 30% flux was heated. Iron yield in the nugget was 93% with 0.14% sulfur for the nodular iron produced. For the slag produced, iron loss in the slag was 7% and total iron contained in the slag was 4.30%. Complete titanium oxide recovery in the slag was achieved. This approach is currently being evaluated for additional research.

---

<sup>50</sup> Anameric (2017). Funding support was provided by University of Minnesota Duluth Permanent University Trust Fund (PUTF).

## End-Product and By-Product Markets

There are a variety of potential markets for the final products and by-products of the beneficiation and hydrometallurgical process. Figure 39, below, displays a diagram that describes some of the potential markets for the various streams of the process.

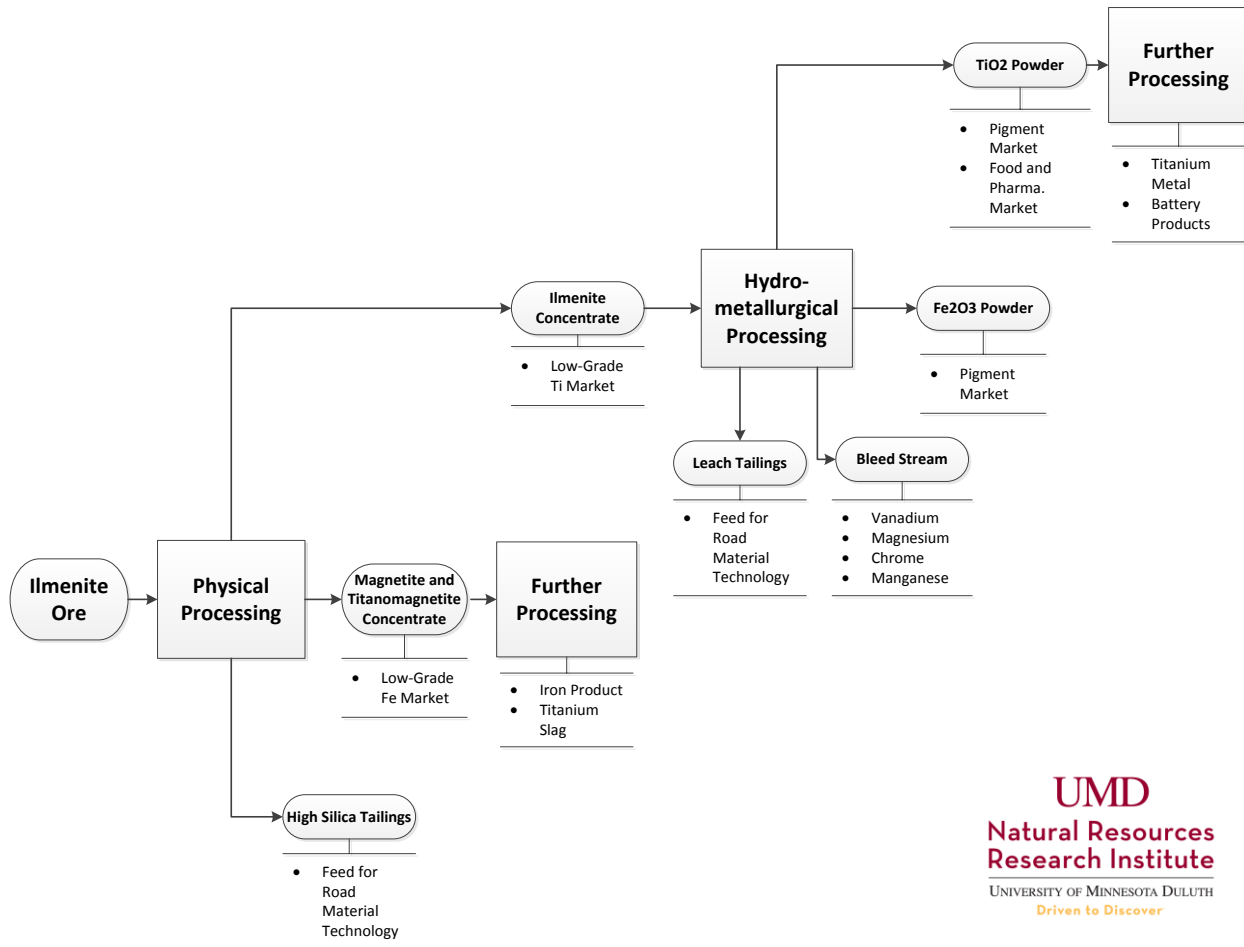

Figure 39: Potential End-Product and By-Product Market Map

## High-Level Capital and Operational Expenditure Estimate

A high-level capital and operational expenditure (CAPEX and OPEX) study was conducted by NRRI and PRO as a front-end loading number for future economic estimates. This study was done to estimate what CAPEX was required to locate and operate a facility in Minnesota. A design factor of 60,000 tpa TiO<sub>2</sub> product was chosen as the base case plant size. NRRI estimated the CAPEX requirement for the beneficiation plant and PRO estimated the CAPEX requirement for the hydrometallurgical plant.<sup>51</sup> PRO estimated the OPEX for both the beneficiation and hydrometallurgical process.<sup>52</sup> Utility costs were calculated using estimated power costs in the state of Minnesota of \$0.08 per kWh and natural gas costs of \$3.50 per MBTU. Table 30 and Table 31 display the estimated plant tonnages for iron and titanium, respectively, based upon the findings in the *Composite Product Recovery* section (above).

**Table 30: Estimated Plant Tonnage Rates and Iron Product Recovery**

Unit Operation	Throughput (tpa)	Throughput (tpd)	Throughput (tph)
Crude Ore Mined	497,021	1,362	56.7
Comminution	497,021	1,362	56.7
Beneficiation	497,021	1,362	56.7
Concentrate Regrinding	226,356	620	25.8
Leaching	226,356	620	25.8
Solvent Extraction	86,581	237	9.9
Precipitation/Calcination	86,408	237	9.9
<b>Composite Fe<sub>2</sub>O<sub>3</sub> Product</b>	<b>82,088</b>	<b>225</b>	<b>9.4</b>

**Table 31: Estimated Plant Tonnage Rates and Titanium Product Recovery**

Unit Operation	Throughput (tpa)	Throughput (tpd)	Throughput (tph)
Crude Ore Mined	497,021	1,362	56.7
Comminution	497,021	1,362	56.7
Beneficiation	497,021	1,362	56.7
Concentrate Regrinding	226,356	620	25.8
Leaching	226,356	620	25.8
Solvent Extraction	75,150	206	8.6
Precipitation/Calcination	75,000	205	8.6
<b>Composite TiO<sub>2</sub> Product</b>	<b>60,000</b>	<b>164</b>	<b>6.8</b>

The high-level cost estimate found that the total CAPEX for a 60,000 tpa TiO<sub>2</sub> facility was approximately \$164.2M USD to produce a >99% pure TiO<sub>2</sub> powder product while mining approximately 0.5 Mtpa crude ore. The CAPEX was estimated at \$44.9M USD for the beneficiation plant and \$119.3M USD for the hydrometallurgical plant. These figures do not include components such as permitting, land acquisition, or development costs. The detailed

<sup>51</sup> Study conducted with assistance of E. Burga of Andeburg Consulting Services, Inc.

<sup>52</sup> Study conducted with assistance of E. Burga of Andeburg Consulting Services, Inc.

CAPEX estimate for the beneficiation and hydrometallurgical facilities can be found in Appendix 16 and Appendix 17, respectively.

The high-level cost estimate found that the total OPEX for a 60,000 tpa  $\text{TiO}_2$  facility was approximately \$795 per ton of  $\text{TiO}_2$  product. The estimated iron oxide production was estimated at 82,088 tpa  $\text{Fe}_2\text{O}_3$ . The estimated credit for the iron oxide product was approximately \$82 per ton of  $\text{TiO}_2$  product.<sup>53</sup> This by-product credit has an adjusted production cost of \$713 per ton of  $\text{TiO}_2$ . A cost of \$125 per ton of ilmenite concentrate was used for this study; however, the actual production cost for ilmenite concentrate at production scale will likely be lower. The study estimated 53 operators for the beneficiation plant and 97 operators for the hydrometallurgical plant for a total of 150 jobs at this facility. These figures do not include components such as by-product processing or tailings/discharge disposal costs. The detailed OPEX estimate for the process can be found in Appendix 18. A production cost of under \$1,000 per ton of  $\text{TiO}_2$  appears favorable as the average estimated  $\text{TiO}_2$  production costs of other producers is approximately \$2,325 per ton of  $\text{TiO}_2$ , with Chemours being the low-cost producer at an estimated \$1,746 per ton of  $\text{TiO}_2$  product.<sup>54</sup>

## Titanium Dioxide Product Marketing Study

A marketing study for  $\text{TiO}_2$  powder was conducted by the University of Minnesota Duluth Center for Economic Development (CED). The focus of this study was to investigate high purity  $\text{TiO}_2$  powder for use in current markets. However, additional opportunities may be found with further technical and marketing research. The following is a summary of the information contained in the CED marketing report<sup>55</sup>:

### *Introduction*

The  $\text{TiO}_2$  industry was found to contain few producers and a large number of consumers for various end-use applications. The majority (92%) of  $\text{TiO}_2$  in the USA is used in paints and coatings, plastics, and paper. There are few pigment substitutes as  $\text{TiO}_2$  has superior characteristics in terms of opacity, whiteness, and durability.  $\text{TiO}_2$  products are characterized using attributes such as chemical purity, particle size, and optical properties (e.g., whiteness and brightness).

### *Supply and Price*

Ilmenite is a titanium-iron oxide mineral and is the primary source of  $\text{TiO}_2$ . Currently, Rio Tinto, Iluka Resources, Exxaro Resources, and Kenmare Resources provide approximately 60% of the global supply of ilmenite. The price for ilmenite has declined since 2012 and currently sells for approximately \$160/ton to \$180/ton. Approximately 45-50% of ilmenite is mined for the purpose of producing  $\text{TiO}_2$ . Nearly all (~98%) of  $\text{TiO}_2$  is used for pigment applications that require white opacity and brightness such as paints and coatings.

---

<sup>53</sup> Assumes value of \$60 per ton of  $\text{Fe}_2\text{O}_3$  product.

<sup>54</sup> Argex Titanium Inc. (2017).

<sup>55</sup> The full marketing report, including references for the data/information in this section, can be found in Appendix 19.

Few producers (typically five to seven) provide approximately 60-70% of global supply of TiO<sub>2</sub>; four of these companies are headquartered in the USA including Chemours, Huntsman, Kronos, and Tronox. Chinese TiO<sub>2</sub> production is growing dramatically and these China based companies provide much of the remaining global supply. Henan Billions Chemicals is the leading Chinese producer. Major suppliers typically enter into supply agreements with large end users with terms of not more than six months. The price of TiO<sub>2</sub> has averaged \$3,604/ton from 2012 to 2015, hit a low of \$2,646/ton in early 2016, and is projected to average \$3,047/ton from 2017 to 2022.

The supply side of TiO<sub>2</sub> production is going through a consolidation. Most of the major industry producers were once part of larger conglomerates (e.g., DuPont owned Chemours, Kerr-McGee owned Tronox, etc.). Currently, Tronox is purchasing Cristal, the largest foreign producer, to create the largest TiO<sub>2</sub> producer in the world. Huntsman is planning to spin-off Venator Materials. In addition, Huntsman and Chemours have removed a combined 270,000 tpa of capacity. The result should lead to more price discipline for TiO<sub>2</sub>.

### ***Demand and Price***

The production of TiO<sub>2</sub> is used for paints and coatings, plastics, paper, inks, and a variety of other applications. Application usage for the USA market is listed below:

- a. Paints and coatings make up approximately 60% of the USA TiO<sub>2</sub> market and demand to increase ~1.9%/yr. to ~490,000 tpa by 2020. PPG and Sherwin Williams are the largest producers of paint with ~25% of the global market. This market share will increase as PPG is attempting to purchase Akzo Nobel and Sherwin Williams is acquiring Valspar. Other large paint manufacturers include Valspar, Masco Corp, Behr Process Corp, and Akzo Nobel.
- b. Plastics make up ~20% of USA TiO<sub>2</sub> market and demand is to increase <1%/yr. to ~195,000 tpa by 2020. The top five global plastics manufacturers are ExxonMobil, ENI, BASF, Dow Chemical, and SABIC.
- c. Paper makes up ~12% of USA TiO<sub>2</sub> market and demand to remain unchanged at ~77,000 tpa by 2020. The top five global paper producers are International Paper, Nine Dragon, West Rock, UPM and Stora Enso.
- d. Printing ink make up ~3% of the USA TiO<sub>2</sub> market and demand is expected to be stable. The top five global ink manufacturers are DIC/Sun Chemical, Flint Group, Toyo Ink, Sakata INX, and Siegwark Group.
- e. All other applications of TiO<sub>2</sub> make up ~5% of the USA TiO<sub>2</sub> market at ~24,000 tpa by 2020:
  - i. Food,
  - ii. Pharma,
  - iii. Cosmetics,
  - iv. Textiles,
  - v. Electronics,
  - vi. Ceramics, and
  - vii. Construction materials.

Overall demand for TiO<sub>2</sub> in the USA is expected to increase ~1.4%/year from 747,000 tpa in 2015 to 800,000 tpa by 2020. In comparison, China demand for TiO<sub>2</sub> is expected to increase ~5.6%/year through 2020. Continued expansion in building construction activity is expected to drive the USA growth in demand due to its position as a major market for paints and plastics. The average price of TiO<sub>2</sub> was \$3,604/ton from 2012 to 2105. The average price of TiO<sub>2</sub> is projected to be \$3,047/ton from 2017 to 2020. TiO<sub>2</sub> currently trades at ~\$3,200/ton.

### ***Markets***

The largest market for TiO<sub>2</sub> is paintings and coatings, but competition is high and Argex Titanium Inc. has contracted their entire new production on this market segment by partnering with PPG<sup>56</sup>. Plastics and paper comprise ~32% of the market demand, but future demand is expected to be stable for plastics and continued decline for paper. Printing ink comprises ~3% of the market and with expected modest growth. This could be a market opportunity for Minnesota production. A Minnesota based operation would have to replace current suppliers providing TiO<sub>2</sub> for paint, paper, plastics, and ink applications. This is possible if the product is provided to the manufacturers at a higher purity level and lower price (e.g., differentiators). The operation could supply a niche market, such as electronics, but quantity demanded would be very small relative to the expected production capacity.

The food and pharma industries comprise only 1% of the market, but overall quantity demanded is low. TOHO Titanium Co. LTD of Japan produces high purity TiO<sub>2</sub> for the electronics market and demand has been on a steep upward trend since 2008. The demand is projected to continue to increase through 2021, but overall quantity demanded is small. Overall demand for TiO<sub>2</sub> for the applications in the “Other” products category is projected to grow modestly to ~24,000 tpa (e.g., small quantity demanded). A graphical depiction of the supply and demand for the USA TiO<sub>2</sub> industry can be seen in Figure 40, below.

---

<sup>56</sup> PRO has a technology licensing agreement with other entities. This relationship is outlined in the Intellectual Property Management section on page 67.

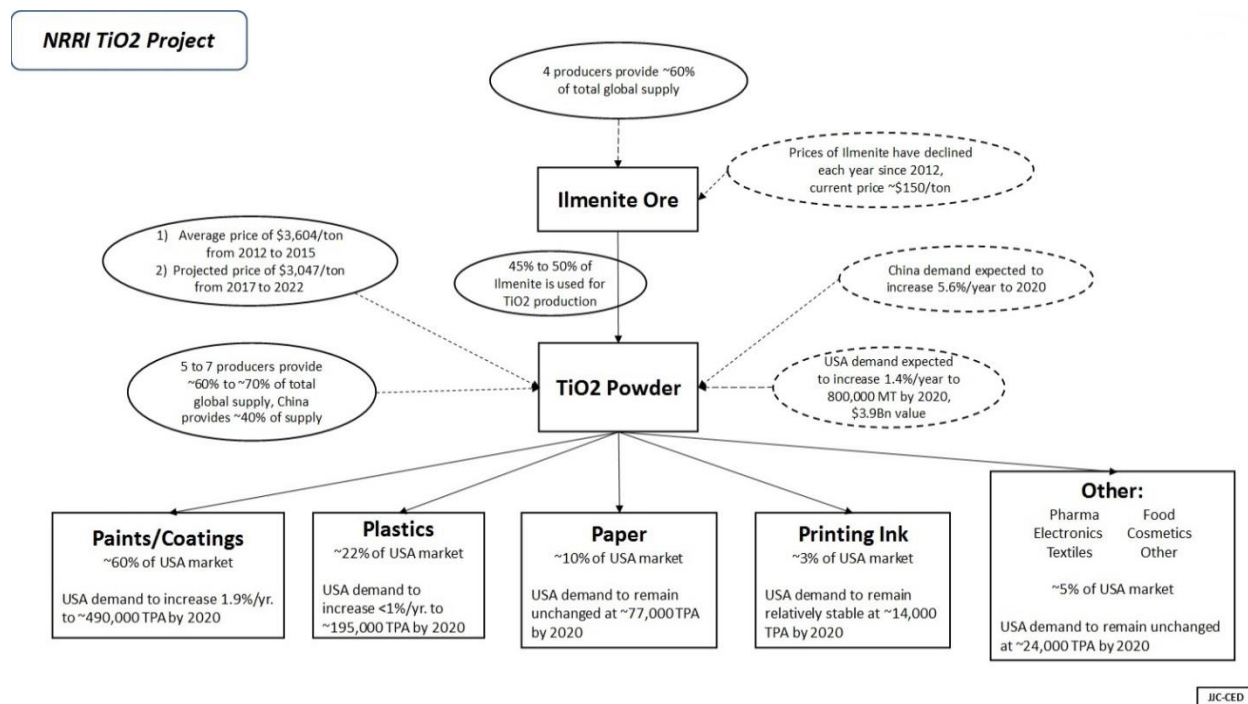

Figure 40: Supply/Demand Diagram for USA TiO<sub>2</sub> Industry

Minnesota-produced TiO<sub>2</sub> could potentially also be used as a feedstock for further processing such as titanium metal or lithium titanate, for example. However, additional research is required to determine technical feasibility before determining market potential. As this technology progresses and higher product purities are obtained, further innovations and applications for this titanium dioxide material may also arise in the future.

### Production Opportunities

Based upon current understanding of the titanium dioxide market and technology presented in this project, below is a list of opportunities for a Minnesota-based TiO<sub>2</sub> production facility:

1. Produce high purity TiO<sub>2</sub> for the paint/coatings industry, but obtain a supply agreement from producers with manufacturing facilities in the area (e.g., Sherwin-Williams/Valspar).
2. Produce high purity TiO<sub>2</sub> for the plastics industry, but obtain a supply agreement from producers with manufacturing facilities in the area (e.g., Dow Chemical, PolyOne Corp, SABIC, etc.).
3. Determine what products can use high purity TiO<sub>2</sub> that currently do not (substitute an input). Find a specialty market.
4. Determine what products currently use high purity TiO<sub>2</sub> at small quantities, but are projected to increase demand above current overall market levels as the demand for the niche product increases.

## Discussion

High purity iron oxide and titanium dioxide products were successfully produced from Minnesota ilmenite. Furthermore, by-products from the beneficiation plant were tested with two technologies and showed initial success. Throughout the testing program opportunities to improve the beneficiation and hydrometallurgical processes were found. The sections below briefly discuss some of these opportunities for future consideration. Of prime importance was increasing the titanium recovery throughout the process.

The most important optimization testing for the beneficiation circuit is in the primary and regrind mill grind targets. Fine ilmenite losses were discovered in the beneficiation circuit as well as in the magnetite/titanomagnetite circuit, so grind control will be critical in future testing programs. Conducting variability testing with the current flowsheet may also determine other beneficiation techniques to increase iron and titanium recovery. Removal of the lizardite, chlorite, and hornblende from the ilmenite concentrate should be investigated with the goal of increasing titanium grade while retaining a high titanium recovery.

Based on observations and results from the small and large pilot-scale operations challenges were found which can be improved. The first opportunity for improvement is the rate of oxidation of the iron. Pilot testing found that to convert the 25 g/L  $\text{Fe}^{2+}$  iron from  $\text{Fe}^{2+}$  to  $\text{Fe}^{3+}$  took approximately 50 hours. Research could be conducted to improve oxidation by mechanical means such as pressure oxidation or by chemical reagent addition. Secondly, the solvent extraction disengagement of the organic and aqueous phase was slow which led to some solution entrainment. To improve phase disengagement, modifications could be made to the organic composition, such as increasing the volume percent of modifier or using a different modifier.

Finally, a major challenge was the filtration of the  $\text{TiO}_2$  precipitate. Due to the very small particle size (approximately 400 nm) product losses occurred as the filter papers and cloths were unable to retain the solids. To improve filtration testing various filter cloth types would be required. Another method to improve the filtration could be the addition of a flocculant. However, it is important to observe if the flocculant affects the product purity and characteristics of the final product.

The high-level CAPEX/OPEX study showed potential for low-cost and high-purity production of  $\text{TiO}_2$  powders products. However, value added products may also be produced from the iron strip solution or iron oxide powder including reduced iron or metallic iron for powder metallurgical uses. Production of high-value products could also be researched from the titanium strip solution or  $\text{TiO}_2$  powder, such as titanium metals or lithium titanate for battery production. The opportunity to recover other components from the titanium raffinate is also a possibility but requires more information and testing to determine if this is technically and economically feasible.

## Future Testing Recommendations

The areas to focus on in future beneficiation testing programs would include the items outlined in the *Discussion* section (above) as well as investigating variability testing to determine how various Minnesota ilmenite samples react to the current beneficiation and hydrometallurgical process flowsheet. It is also recommended that drill core samples be provided to NRRI for testing and/or a drilling campaign be conducted to produce sample quantities for additional bench- and pilot-scale testing. Additional drilling and characterization data would also improve the knowledge of the resource and could promote more development work. Continued research on the by-products from the beneficiation process is recommended to determine highest value use of these streams.

The areas to focus on in future hydrometallurgical testing programs would include the items outlined in the *Discussion* section (above) as well as the recycling of the raffinate to the leaching process. The recycle testing would properly demonstrate the effects of impurities on the leaching efficiencies of iron and titanium, the effects of impurities on the solvent extraction circuits, and if the concentrations of the impurities are high enough for potential products to be extracted from the bleed stream via solvent extraction. Some of the potential products could include elements such as magnesium, vanadium, and manganese. Average titanium raffinate showed vanadium, magnesium, chrome, and manganese concentrations of 144 ppm, 64,294 ppm, 49 ppm, and 240 ppm, respectively. Manganese can be used in metal alloys, as manganese dioxide ( $\text{MnO}_2$ ) in battery products, and as a sulfate ( $\text{MnSO}_4$ ) for agricultural purposes. It can also be precipitated as a carbonate ( $\text{MnCO}_3$ ) which can be sold as an intermediate product other processes. Vanadium is also used in metal alloys as well as vanadium pentoxide ( $\text{V}_2\text{O}_5$ ) which is used commercially as a catalyst.

## Future Considerations

It is recommended that the CTL technology be on-boarded at the NRRI facility in Coleraine at pilot-scale so the beneficiation and hydrometallurgical processes can be coupled and stakeholders have access to observe and participate in testing. This process facility could encompass beneficiation, leaching, solvent extraction, and end-product development on a variety of samples. Optimization and variability testing could be conducted in Minnesota with participation of various stakeholders to decrease the project risk and increase the time to market. Environmental aspects could also be investigated on a detailed level to aid in future permitting.

Following the development and optimization testing it is recommended that a full feasibility analysis be undertaken to establish the commercial requirement for process implementation. A full feasibility study will include the following components:

- Full characterization of the ore body and surrounding region,
- Development of marketing plan for all potential products and applications,
- Characterization of all impacts (land, air, and water) and necessary controls,
- Confirmation of process material balances and processing costs,
- Equipment required and sizing,
- Plant infrastructure needed,
- Environmental studies and permitting required,
- Plant engineering design,
- Investment modeling and economic analysis, and
- Preparations for investor attraction.

## Conclusions

Ten tons of Longnose ilmenite material was beneficiated using a modified flowsheet based upon historical beneficiation testing at NRRI. Grinding energy consumption was estimated at 21.1 kWh per ton. The ilmenite concentrate was found to have the estimated chemical assay: 38.9% TiO<sub>2</sub>, 31.1% Total Fe, 6.4% SiO<sub>2</sub>, 7.6% MgO, and 0.32% V<sub>2</sub>O<sub>5</sub> with an estimated weight recovery of 45.5% and a TiO<sub>2</sub> recovery of 71.3%. The majority of the ilmenite concentrate sample consisted of ilmenite with gangue constituents of lizardite, chlorite, and hornblende. Overall ilmenite recovery was estimated at 64%.

From the ilmenite concentrate produced by NRRI, bench scale testing was conducted at PRO to determine leaching parameters as well as solvent extraction isotherms for iron and titanium. When re-grinding the ilmenite concentrate to 80% passing 37 microns, a leaching efficiency of 89% for iron and 88% for titanium was achieved. The ilmenite concentrate re-grind was estimated to consume 5.8 kWh per ton; therefore, total grinding energy consumption was estimated at 26.9 kWh per ton. Using the bench-scale data, a counter-current small pilot-scale plant was operated to confirm previous results as well as identify operational issues. During the small pilot-scale operation, iron and titanium leaching efficiencies were 80.5% and 80%, respectively. The extraction and stripping efficiencies of the iron circuit were 99.9% and 99.9%, respectively, whereas the extraction and stripping efficiencies were of the titanium were 99.7%

and 99.8%, respectively. Upon completion of the small pilot-scale plant testing, a large pilot-scale plant was operated to produce TiO<sub>2</sub> product for market evaluation. During operation of the large pilot-scale testing, iron and titanium leaching efficiencies were slightly improved at 83% and 81%, respectively. However, leaching optimization showed the potential to increase leaching efficiencies to approximately 84%. Operation of the solvent extraction circuits reached the same extraction and stripping efficiencies of the small pilot-scale operation.

Iron oxide and titanium dioxide powders were produced on a batch-basis. A 98.5% pure Fe<sub>2</sub>O<sub>3</sub> powder was generated via precipitation and calcination. From the titanium strip solution produced in the pilot plant, TiO<sub>2</sub> was precipitated to produce a crystalline rutile powder with a purity of 99.3% TiO<sub>2</sub>. The TiO<sub>2</sub> powder product was further characterized by determining its CIE L\*a\*b\* measurements as well as its particle size distribution. These results were compared to a commercially available product: DuPont™ Ti-Pure® R350. A purity optimization study found that a titanium dioxide powder at a purity level of 99.8% was possible by optimizing the titanium solvent extraction and precipitation parameters. Finally, analysis of the solids tailings was conducted to compare to Ontario environmental standards. It was found that the tailings sample was inert compared to the Ontario standards.

A high-level capital and operational expenditure (CAPEX and OPEX) study was conducted by NRRI and PRO as a front-end loading number for future economic estimates. A design factor of 60,000 tpa TiO<sub>2</sub> product was chosen as the base case plant size. The high-level cost estimate found that the total CAPEX for a 60,000 tpa TiO<sub>2</sub> facility was approximately \$164.2M USD to produce a >99% pure TiO<sub>2</sub> powder product from mining 0.5 Mtpa crude ore. The high-level cost estimate found that the total OPEX for a 60,000 tpa TiO<sub>2</sub> facility was approximately \$795 per ton of TiO<sub>2</sub> product. The estimated iron oxide production was estimated at 82,088 tpa Fe<sub>2</sub>O<sub>3</sub>. The estimated credit for the iron oxide product was approximately \$82 per ton of TiO<sub>2</sub> product. This by-product credit has an adjusted production cost of \$713 per ton of TiO<sub>2</sub>. A production cost of under \$1,000 per ton appears favorable compared to other producers in the market, as the average cost of production is estimated at over twice that cost.

A marketing study for TiO<sub>2</sub> powder was conducted by the University of Minnesota Duluth Center for Economic Development (CED). The focus of this study was to investigate high purity TiO<sub>2</sub> powder for use in current markets. The TiO<sub>2</sub> industry was found to contain few producers and a large number of consumers for various end-use applications. The majority of TiO<sub>2</sub> is used in paints and coatings, plastics, and paper. There are few suitable pigment substitutes to TiO<sub>2</sub> due to its optical properties. Other uses for TiO<sub>2</sub> include food, pharma, cosmetics, textiles, electronics, ceramics, and construction materials. Titanium dioxide is also used as a feedstock for further processing, such as titanium metal production. However, additional research is required to determine the technical feasibility of using Minnesota titanium resources for this purpose before determining marketing potential. As this technology progresses and higher product purities are obtained, further innovations and applications for this titanium material may also arise in the future.

Based upon current understanding of the titanium dioxide market and technology presented in this project, below is a list of opportunities for a Minnesota-based TiO<sub>2</sub> production facility:

1. Produce high purity TiO<sub>2</sub> for the paint/coatings industry, but obtain a supply agreement from producers with manufacturing facilities in the area.
2. Produce high purity TiO<sub>2</sub> for the plastics industry, but obtain a supply agreement from producers with manufacturing facilities in the area.
3. Determine what products can use high purity TiO<sub>2</sub> that currently do not (substitute an input). Find a specialty market.
4. Determine what products currently use high purity TiO<sub>2</sub> at small quantities, but are projected to increase demand above current overall market levels as the demand for the niche product increases.

Opportunities for improving the beneficiation and hydrometallurgical processing were discussed. It is recommended that the CTL technology be on-boarded at the NRRI facility in Coleraine at pilot-scale so the combined beneficiation and hydrometallurgical processes can be coupled and potential stakeholders have access to observe testing. This demonstration facility could encompass beneficiation, leaching, solvent extraction, and end-product development on a variety of samples. Following the scale-up testing, it is recommended that a full feasibility analysis be undertaken to establish the commercial requirement for process implementation.

## Sources

1. Anameric, B. February 3, 2017. *Production of Nodular Iron Using Minnesota Ilmenite Low Intensity Magnetic Separator (LIMS) Concentrate*. Funding Source: University of Minnesota Duluth Permanent University Trust Fund. NRRI/TR-2017-03.
2. Argex Titanium Inc. March 2017. Presentation: *Argex Titanium Inc. March 2017*. Accessed March 26, 2017 at: <http://argex.ca/images/pdf/en/Presentation/Argex-March-2017.pdf>.
3. Benner, B. August 9, 2001. *Minnesota Ilmenite Processing Using High Pressure Rolls*. University of Minnesota Duluth, Natural Resources Research Institute, Coleraine Minerals Research Laboratory. CMRL/TR-01-13. NRRI/TR-2001/25. Project #5601201.
4. Benner, B., and Niles, H. December 1994. *Pilot Plant Beneficiation Tests of a Bulk Sample of Ilmenite Ore Provided by American Shield Company*. University of Minnesota Duluth, Natural Resources Research Institute, Coleraine Minerals Research Laboratory. CMRL/TR-94-15.
5. Benner, B., and Niles, H. October 1, 2002. *Potential Value Added Products from the Minnesota Ilmenite Deposits*. University of Minnesota Duluth, Natural Resources Research Institute, Coleraine Minerals Research Laboratory. CMRL/TR-02-03, NRRI/TR-2002/19. Project #5601201.
6. Explore Minnesota: Titanium. March 2015. Accessed February 27, 2016, at: [http://mn.gov/irrrb/images/2015%2520Explore%2520TITANIUM\\_final.pdf](http://mn.gov/irrrb/images/2015%2520Explore%2520TITANIUM_final.pdf).
7. Elsner, H. 2010. Ilmenite and leucoxene. In *Heavy Minerals of Economic Importance* (pp. 23-55). Hannover, Lower Saxony, Germany: Federal Institute of Geosciences and Natural Resources (BGR).
8. Iluka Resources. 2014. *The Mineral Sands Industry Factbook*. Retrieved March 11, 2017, from Iluka Resources: [https://www.iluka.com/docs/default-source/industry-company-information/the-mineral-sands-industry-factbook-\(feb-2014\)](https://www.iluka.com/docs/default-source/industry-company-information/the-mineral-sands-industry-factbook-(feb-2014)).
9. McManus, P. 2013. Overview of the Australasian Mineral Sands Industry. In W. J. Rankin (Ed.), *Australasian Mining and Metallurgical Operating Practices: the Sir Maurice Mawby Memorial Volume* (3<sup>rd</sup> ed., Vol. 2, pp. 1687-1691). Carlton, Victoria: Australasian Institute of Mining and Metallurgy.

10. Niles, H. B. April 26, 1996. *Beneficiation of the Longnose Ilmenite Deposit*. Preliminary, Unpublished Report. University of Minnesota Duluth, Natural Resources Research Institute, Coleraine Minerals Research Laboratory. CMRL/TR-96-29.
11. Patelke, R., and Severson, M. January 5, 2005. *A History of Copper-Nickel and Titanium Oxide Test Pits, Bulk Samples, and Related Metallurgical Testing in the Keweenawan Duluth Complex, Northeastern Minnesota*. University of Minnesota Duluth, Natural Resources Research Institute. NRRI/TR-2005/01. Project # 1896-783-1077.
12. Severson, M., and Hauck, S. March 1990. *Geology, Geochemistry, and Stratigraphy of a Portion of the Partridge Intrusion*. University of Minnesota Duluth, Natural Resources Research Institute. NRRI/GMIN-TR-89/11.
13. Technical Report on the Longnose Ilmenite Project, Minnesota, USA. January 27, 2012. Report Prepared for Cardero Resource Corp. Written by SRK Consulting Inc. SRK Project Number 2CC031.004. Longnose NI43-101.
14. U.S. Geological Survey (USGS). 2014. Titanium dioxide pigment statistics, in Kelly, T.D., and Matos, G.R., comps., *Historical statistics for mineral and material commodities in the United States: U.S. Geological Survey Data Series 140*, accessed March 5, 2017, at <http://minerals.usgs.gov/minerals/pubs/historical-statistics/>.
15. U.S. Geological Survey (USGS) Iron. 2017. *USGS Mineral Commodity Summaries*. Pages 102-105.
16. U.S. Geological Survey (USGS) Magnesium. 2017. *USGS Mineral Commodity Summaries*. Pages 90-94.
17. U.S. Geological Survey (USGS) Titanium. 2017. *USGS Mineral Commodity Summaries*. Pages 176-179.
18. U.S. Geological Survey (USGS) Titanium Statistics and Information. Accessed May 13, 2017, at: <https://minerals.usgs.gov/minerals/pubs/commodity/titanium/>.
19. Zanko, L. 2017. *A Preliminary Evaluation of Ilmenite Ore Processing By-Products as Road Repair Compound Components*. Funding Source: MnDOT Contract 99008, Work Order 241. Preliminary, Unpublished Report.

## Peer Review Information

The two peer reviewers for this report were Dr. Harvey Thorleifson and Dr. Richard Davis.

Harvey Thorleifson is Director of the Minnesota Geological Survey, State Geologist of Minnesota, and Professor of Earth Sciences at the University of Minnesota. He holds a Ph.D. in geology from University of Colorado. He was a Research Scientist with the Geological Survey of Canada from 1986 until 2003, where his research included mineral exploration-related topics.

Richard Davis is Professor of Chemical Engineering at the University of Minnesota Duluth (UMD). He received PhD and BS degrees in Chemical Engineering from the University of California Santa Barbara and Brigham Young University, respectively. He serves as the UMD Chemical Engineering Department head where he was instrumental in developing courses in particle technology, mineral processing, extractive metallurgy, as well as recruiting faculty in these areas. Dr. Davis has published extensively in the area of iron ore processing modeling and developed a mass and energy balance model for iron oxide pellet induration. His current research focuses on mineral process modeling and simulation for environmental management, air pollution control, and energy efficiency. He has consulted with mineral producers in Minnesota for over two decades. He serves on the State of Minnesota Minerals Coordinating Committee and is the faculty adviser to the UMD student chapter of the Society of Mining, Metallurgy, and Exploration.

### *Peer Review Contact Information*

Harvey Thorleifson Ph.D., P.Geo., D.Sc.,  
Director, Minnesota Geological Survey; State Geologist of Minnesota  
Professor, Department of Earth Sciences; College of Science and Engineering  
University of Minnesota  
2609 West Territorial Road  
St Paul MN 55114  
E: thorleif@umn.edu

Richard A. Davis, Ph.D.  
Chemical Engineering Department Head  
Professor of Chemical Engineering  
University of Minnesota Duluth  
176 Engineering  
1303 Ordean Court  
Duluth, MN 55812  
E: rdavis@d.umn.edu

## Intellectual Property Management

Beneficiation technology demonstrated by NRRI in this project is an adaptation of techniques and practices known in the art of mineral extraction technologies. While specifics regarding the absolute methods developed and applied are NRRI IP, no patentable technology is anticipated.

The unique hydrometallurgical technology employed in achieving high purity TiO<sub>2</sub> from Minnesota ilmenite ores was developed and patented by Process Research Ortech (PRO) of Mississauga, Ontario. Prior to the onset of this project, PRO sold the technology to Canadian Titanium Limited (CTL). Argex Titanium Inc., another Canadian company investing in the technology, subsequently gained ownership of 50.1% of any licensing fees resulting from the technology, leaving PRO Group and TiDev Global Inc. with 24.95% of licensing fees each. Per separate documentation, PRO and NRRI will agree to share the PRO Group share in any licensing fees equally generated in the US as a result of this collaboration.

## Project Management Summary

The awarded grant’s start date was May 31, 2016, and the end date was June 30, 2017, bringing the duration of the project to total of 13 months. NRRI was successful to complete the project in mid-May, 45 days prior to the official grant finish date, and an estimated 4% under budget. With approvals from IRRRB, NRRI was also able to expand the scope of the study and to deliver more than in the original project scope, including a titanium dioxide purity study, iron product development, and titanium dioxide marketing study.

During the course of the project, and through application of proper project management tools, NRRI continuously monitored the cost, schedule, progress and deliverables of the project. A summary of project timeline, along with the completion dates of important milestones is shown in the Gantt chart below.

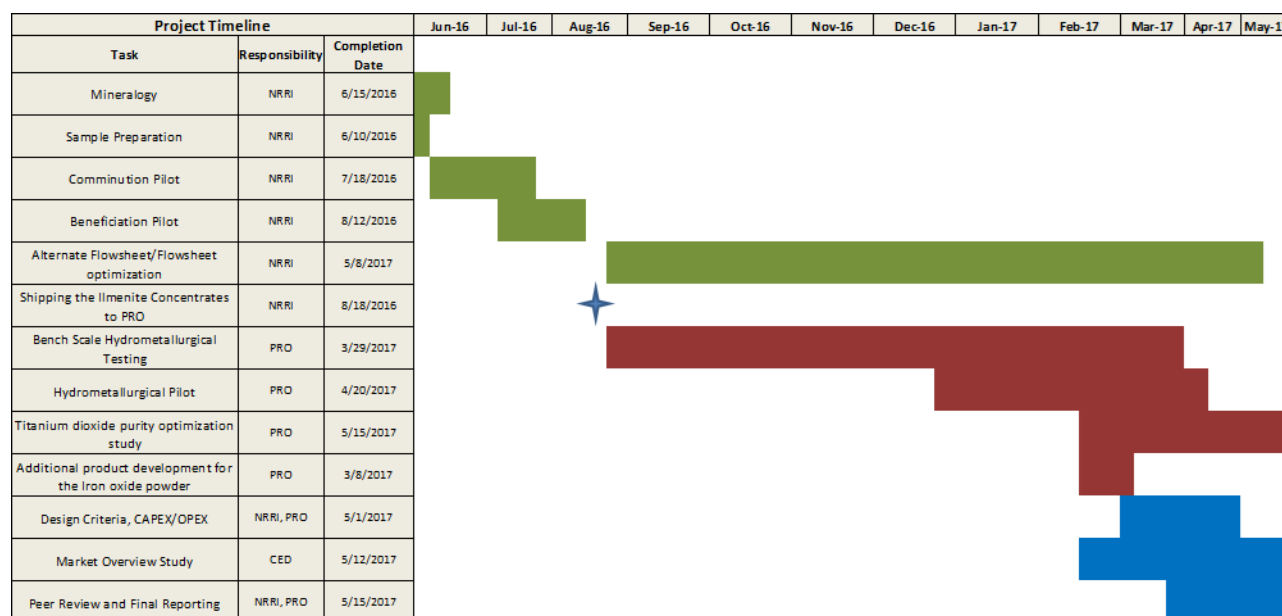

The figure below demonstrates the project Expenditure (%) and Progress (%) through time.



## Special Thanks

The authors would like to recognize and thank the project sponsors: Iron Range Resources and Rehabilitation Board (IRRRB), University of Minnesota Duluth Executive Vice Chancellor for Academic Affairs (UMD EVCAA), and University of Minnesota Office of the Vice President for Research (UM OVPR) for funding this research project.

The authors would like to recognize and thank Mr. Bill Ulland and American Shield for approving the use of the Longnose ilmenite bulk sample for this test program.

The authors would like to recognize and thank NRRI associate Dr. Dean Peterson for his resource characterization work. The authors would like to recognize and thank NRRI associate Dr. Rodney Johnson for his mineralogical work.

The authors would like to recognize and thank NRRI safety officer Ms. Gina Gould.

The authors would like to recognize and thank NRRI technician staff including Mr. Donald Reiser, Mr. Pat Adams, Mr. Mike Swanson, Mr. Shaun Gram, Mr. Richard Bellefy, Mr. Kevin Jamsa, Mr. Anthony Masching, Mr. Roger Koski, and Mr. Joe Cannella. The authors would like to recognize and thank NRRI chemical analysis staff including Mrs. Julie Mutchler, Mr. Jim Sigfrinius, and Mr. Gregory Gargano.

The authors would like to recognize and thank Hart Electric electrician Mr. Brian Ekholm.

The authors would like to recognize and thank Process Research Ortech for their professionalism and participation in this test program, specifically Dr. V.I. (Lucky) Lakshmanan, Dr. Ramamritham (Ram) Sridhar, Mr. Jonathan Chen, Dr. Md Abdul Halim, and Mr. Darcy Tait.

The authors would like to recognize and thank NRRI associates Dr. Basak Anameric and Mr. Lawrence Zanko for the summaries of their research involving the process by-product streams, respectively.

The authors would like to recognize and thank UMD Center for Economic Development collaborators, including Mr. James Croyle, Mrs. Elaine Hansen, and Ms. Brooklyn Pouti.

The authors would like to recognize and thank the peer reviewers Dr. Harvey Thorleifson and Dr. Richard Davis.

The authors would like to recognize and thank all of the NRRI co-PIs on the project for their guidance and leadership, including Dr. Rolf Weberg, Dr. Donald Fosnacht, Dr. George Hudak, and Mr. Richard Kiesel.

The authors would like to recognize and thank NRRI project manager Ms. Shima Hosseinpour.

The authors would like to recognize and thank NRRI administrative staff including Mrs. Nancy Johnson, and Mrs. Robin Oberton.

## Appendices

### *Appendix 1: Titanium Processing, Resource, and Producer Review*

#### Titanium Feedstocks

Titanium feedstocks are minerals containing titanium dioxide (TiO<sub>2</sub>). Key titanium feedstock minerals include ilmenite, leucoxene, and rutile. Beneficiated ilmenite in different forms produces feedstocks such as sulfate and chloride slag and synthetic rutile.

The mineral ilmenite is the primary source of titanium dioxide (TiO<sub>2</sub>), which accounts for about 92% of the world's consumption of titanium minerals. The balance is supplied by rutile, with minor quantities being sourced from leucoxene. World resources of anatase, ilmenite, and rutile total more than 2 billion tons (USGS, 2016).

Naturally occurring ilmenite hosts between 35% and 65% TiO<sub>2</sub> (Geoscience Australia, 2015). For the production of titanium slag and synthetic rutile, ilmenite undergoes further processing to remove iron and other impurities. Synthetic rutile can contain between 88% and 95% TiO<sub>2</sub>, while titanium slag can contain between 72% and 91% (Chatterjee, 2007).

The titanium feedstocks are classified according to their chemical composition, physical characteristics, color, TiO<sub>2</sub> content, and the level of impurities.

Beneficiated titanium feedstocks are used in TiO<sub>2</sub> pigment production via the sulfate process, chloride process, and in titanium metal manufacturing. The balance is used in the production of titanium sponge and fluxes for welding rods, and as a metallurgical flux in iron and steel making. The titanium metal and its alloys are extensively used in aerospace, nonaerospace, and industrial applications (Gambogi, 2003).

In this report, existing beneficiation and pigment production technologies, and those, which have been developed, but are not yet commercially applied, are reviewed.

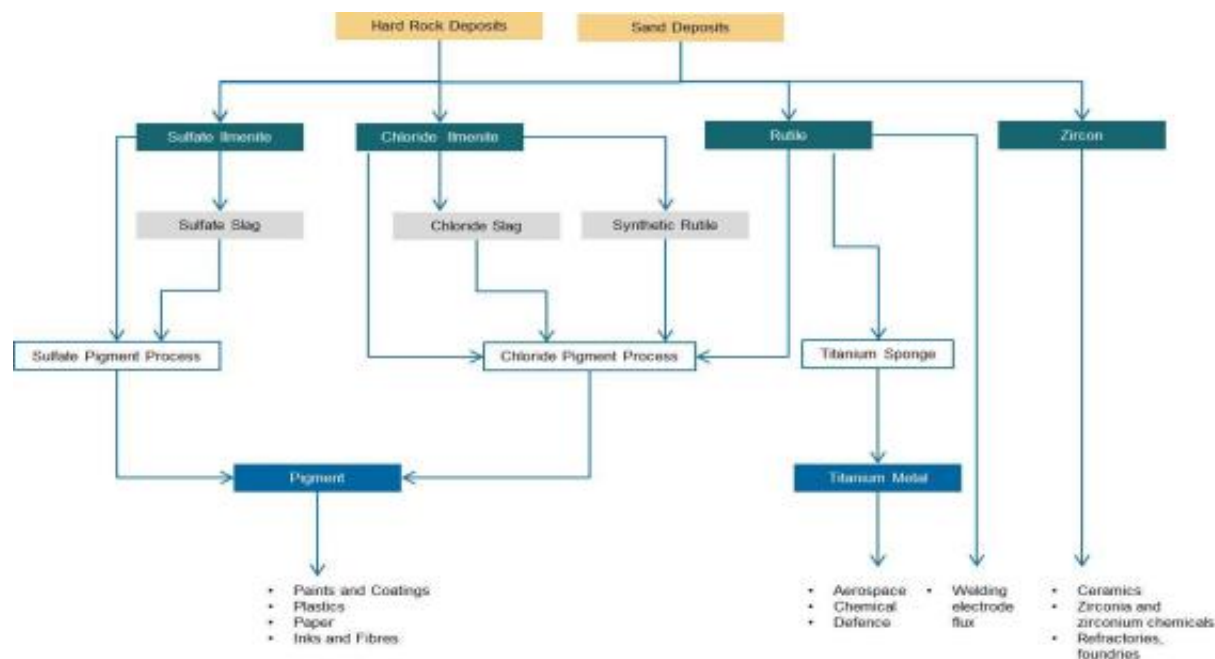

Figure 41: Titanium Industry Feedstock Flow<sup>57</sup>

The two main routes to upgrade ilmenite to chloride/sulfate feedstock are ilmenite smelting and the synthetic rutile route.

### Process for the production of Synthetic Rutile

Ilmenite is beneficiated by various processes to products containing 90–95% TiO<sub>2</sub> known as synthetic rutile. The different processes vary in the degree to which the ilmenite grain is ground, the reduction process and the conditions used in the subsequent removal of iron. Currently, only the Becher and Benilite synthetic rutile processes are used on a commercial basis, and both are based on the solid-state reduction of ilmenite in a rotary kiln followed by leaching to remove the iron from the ilmenite.

#### *Becher Process*

The Becher process is a process for the production of synthetic rutile from ilmenite ore. The process was invented and developed in the 1960s, by R.G. Becher at the Mineral Processing Laboratories of the West Australian Government Chemical Centre and Western Titanium. The ilmenite ore is initially roasted with coal and sulfur at 1200°C in a rotary kiln. The iron oxides in the ilmenite are reduced to the metallic state. Subsequently, coal and ash are rejected by screening and magnetic separation. The reduced metallic iron is precipitated as iron oxide by agitating in water containing ammonium chloride. Wet classification then separates the iron oxide. The synthetic rutile produced by Becher Process contains approximately 93% TiO<sub>2</sub>. Most of the synthetic rutile is used for the manufacture of titanium pigments. Becher process is currently used at the synthetic rutile plants by Iluka Resources at Narngulu and Capel and Tronox Limited at Chandala in Western Australia (Comyns, 2014).

<sup>57</sup> Iluka Resources (2014).

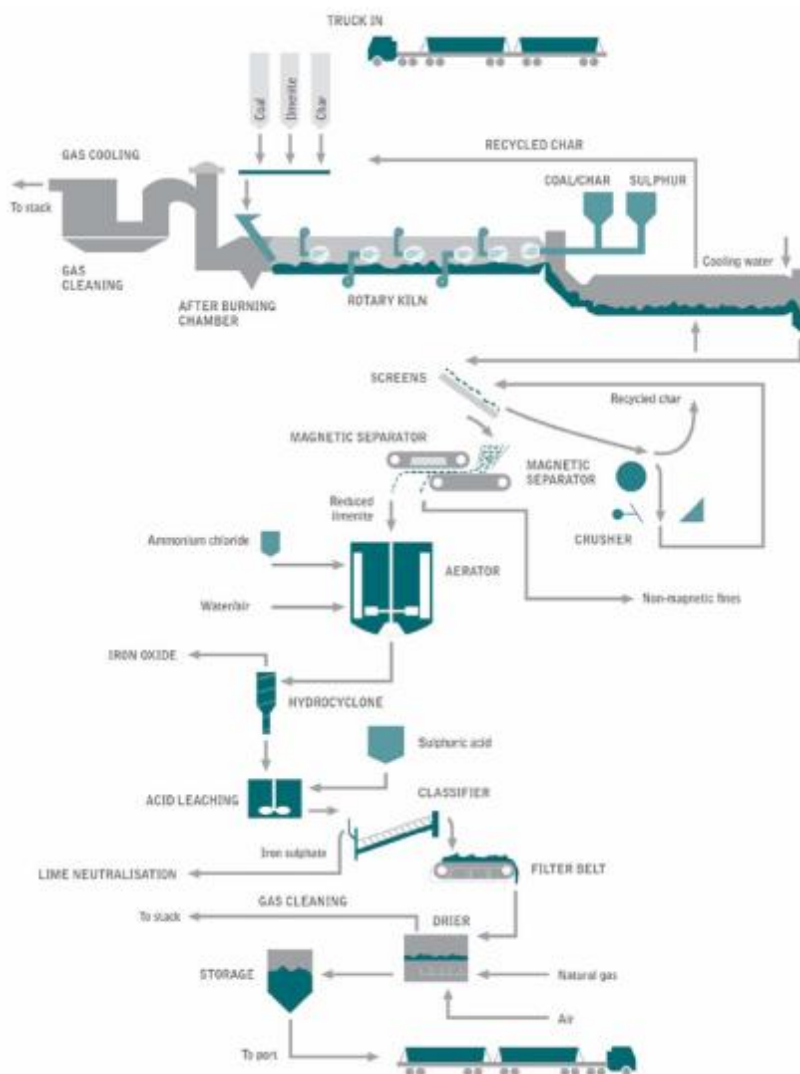

Figure 42: Schematic flow sheet of the synthetic rutile process<sup>58</sup>

### Benilite Process

The Benilite process is also known as the Wah Chang process. The process stemmed with the Wah Chang Corporation and was further developed by the Benilite Corporation of America, Corpus Christi, Texas which is now owned by TOR Minerals. This process is used for upgrading ilmenite by leaching the iron with hot hydrochloric acid. The ore is subjected to a solid-state reduction in a rotary kiln. The reduced ilmenite is subjected to leaching in a rotating, spherical, iron pressure vessel. The spent hydrochloric acid is recovered for reuse by the Woodall–Duckham acid regenerator.

The synthetic rutile product is used as a feedstock for the chloride process. The process is now operated by TOR Minerals at Ipoh (Malaysia), by Dhrangadhra Chemical Works (DCW, at Sahapuram, India), and by Kerala Minerals and Metals (KMML, at Sankaramangalam, India).

<sup>58</sup> AusIMM (2013).

The world's largest Benilite-type plant, operated by Kerr-McGee at Mobile, Alabama, closed in 2003 (Comyns, 2014).

Company	Location	Process	Capacity (tpa)	Feedstock
Iluka Resources	Western Australia	Becher	480 000	Own sources, and purchased 60 % TiO <sub>2</sub> ilmenite
Tiwist Joint Venture	Western Australia	Becher	200 000	62 % TiO <sub>2</sub> Cooljarloo ilmenite
Kerr-McGee	Mobile, USA	Benilite	200 000	Various purchased ilmenites
TOR Minerals (formerly Malaysian Titanium Corp)	Ipoh, Malaysia	Benilite	50 000	Local, 60 - 62 % TiO <sub>2</sub> weathered ilmenite
Kerala Minerals and Metals Limited	Kerala, India	Benilite	30 000	60 % TiO <sub>2</sub> Chavara ilmenite
Cochin Minerals and Rutile Limited	Kerala, India	Benilite	15 000	60 % TiO <sub>2</sub> ilmenite from Indian Rare Earth's operation at Chavara
DCW Limited	Tamil Nadu, India	Wah Chang	20 000	55 % TiO <sub>2</sub> ilmenite from Indian Rare Earth's operation at Manavalakurichi
OSCOM (intermittent operation)	Orissa, India	Benilite	100 000	50 % TiO <sub>2</sub> ilmenite from OSCOM

Figure 43: Global synthetic rutile operations<sup>59</sup>

### Commercial Processes to Produce Titanium Slag

In ilmenite smelting, iron is removed by reduction to metallic iron at a temperature of around 1650°C. Ilmenite smelting yields two products: a titania-rich slag, and high purity pig iron (Pistorius, 2008). This is in contrast with the Becher and Benilite process, where the iron is rejected as a waste product. Titanium slag is used in pigment manufacturing using the sulfate as well as the chloride process.

#### *AC Smelting Technology*

In the AC smelting process, the ilmenite roasted to remove sulfur, or to enhance the removal of chromite, before being smelted with coal in an alternating current (AC), electric furnace. The iron oxide content of the ilmenite is reduced in the presence of reductant (anthracite) to produce metallic iron (pig iron) and carbon monoxide, while a portion of the TiO<sub>2</sub> is reduced to Ti<sub>2</sub>O<sub>3</sub>. The bulk of the impurities present in the ilmenite, and impurities introduced with the solid reductant, such as SiO<sub>2</sub>, Al<sub>2</sub>O<sub>3</sub>, MgO, MnO, CaO, Cr<sub>2</sub>O<sub>3</sub>, V<sub>2</sub>O<sub>5</sub>, and ZrO<sub>2</sub>, are concentrated in the slag.

AC smelting technology is currently used by Rio Tinto Fer et Titane (RTFT) at Sorel, Canada, and Richards Bay Minerals, South Africa; and by TiZir at Tyssedal in Norway (the only such facility in Europe) (Gilman & Taylor, 2001) (Dujardin & Fourcade, 2011).

<sup>59</sup> Gilman & Taylor (2001)

Titania-rich product (QIT acronym)	TiO <sub>2</sub> (tot)	TiO <sub>2</sub>	Ti <sub>2</sub> O <sub>3</sub> <sup>+</sup>	Fe <sup>0</sup>	FeO	Fe <sub>2</sub> O <sub>3</sub>	MgO	SiO <sub>2</sub>	Al <sub>2</sub> O <sub>3</sub>	V <sub>2</sub> O <sub>5</sub>	CaO	MnO	Cr <sub>2</sub> O <sub>3</sub>	S
Run-of-mine (ROM)	32.7	32.7	nil	nil	37.0**	2.92	6.65	4.14	0.30	1.10	0.12	0.13	0.32	
Beneficiated ore (BO)	34.5	34.5	nil	nil	38.2**	2.77	4.93	3.28	0.31	0.77	0.13	0.13	0.22	
Roasted ore (RO)	34.8	34.8	nil	nil	38.9**	2.69	4.55	3.13	0.33	0.76	0.12	0.13	0.04	
Upgraded roasted ore (URO)	37.60	37.60	nil	nil	29.90	27.20	2.70	0.8	0.8	0.3	0.2	0.1	0.10	
Sorelslag	80.00	62.00	18.00	0.50	9.70	nil	5.30	2.60	2.40	0.60	0.50	0.30	0.20	0.084
Oxidized slag (ORPO)	81.84					7.66	5.02	1.50	2.31	0.61	0.35	0.22	0.16	0.009
Heat treated titania slag (HTS)	80.54	72.14	8.40			9.66	5.17	1.59	2.37	0.62	0.29	0.23	0.19	0.004
Upgraded titania slag (UGS)	94.50	94.50	nil	nil	nil	1.5	0.7	1.80	0.50	0.40	0.1	0.01	0.10	0.008

Figure 44: Typical chemical composition of titania-rich products from Rio Tinto Fer et Titane (RTFT) at Sorel, Canada<sup>60</sup>

	ROCK ILMENITE	SAND ILMENITE
TiO <sub>2</sub>	44	51
FeO	34	34
Fe <sub>2</sub> O <sub>3</sub>	14	13
CaO	0,3	0,03
MgO	3,7	0,6
SiO <sub>2</sub>	2,5	0,7
MnO	0,3	0,6
Cr <sub>2</sub> O <sub>3</sub>	0,1	0,06

Figure 45: Indicative quality of Tellnes ilmenite concentrates at TiZir Titanium and Iron in Tyssedal, Norway<sup>61</sup><sup>60</sup> Cardarelli & Guéguin (2007)<sup>61</sup> Hildal & Seim (2016)

	Malyshev, Volgogradsk VSMMP Dnepropetrovsk, Ukraine	Palmoodai Ceylon Mineral Sands Corp. Sri Lanka	Tamil Nadu Leases PON 51 %-Grade V.V. Mineral Tamil Nadu, India	Tamil Nadu Leases TIS 52 %-Grade V.V. Mineral Tamil Nadu, India	Tamil Nadu Leases KPM 53 %-Grade V.V. Mineral Tamil Nadu, India	Kollam Kerala Minerals and Metals Ltd. Kerala, India	Chappara (OSCOM) OR-Grade Indian Rare Earths Ltd. Orissa, India	Manavalakurichi MK-Grade Indian Rare Earths Ltd. Tamil Nadu, India	Chavara Q-Grade Indian Rare Earths Ltd. Kerala, India	North Strathproke Island Cruzor Ilmenite Consolidated Rutile Ltd Queensland, Australia	Eneabba RGC Minerals Sands Ltd Western Australia	Capel WTC-Grade RGC Minerals Sands Ltd Western Australia
<b>Guaranteed</b>												
TiO <sub>2</sub>	≥54.0	≥53.0				≥58.0						
Cr <sub>2</sub> O <sub>3</sub>	≤0.05											
<b>Typical</b>												
TiO <sub>2</sub>	55.3	60.80	50.7	60.1	55.1	50.50	59.88	53.50	52.00	51.50	54.58	63.9
Fe (total)	29.5	23.60					25.34					
FeO	22.0	3.70	27	10.50	20.3	34.04	8.4	28.00	25.00	33.50	18.11	
Fe <sub>2</sub> O <sub>3</sub>	18.3	29.50	17	26.30	19.9	12.43	26.98	15.00	10.00	13.00	23.15	
Cr <sub>2</sub> O <sub>3</sub>	0.035	0.20	0.30	0.13	0.09	0.048	0.04	0.05	0.04	0.04	0.07	0.4
Al <sub>2</sub> O <sub>3</sub>	0.8	0.98	0.45	0.70	0.9	0.45	1.16	0.30	0.40	0.30	1.18	2.9
V <sub>2</sub> O <sub>5</sub>	0.15	0.22	0.22	0.15	0.22	0.23	0.2	0.20	0.18	0.19	0.09	0.19
Nb <sub>2</sub> O <sub>5</sub>	0.20	0.12	0.05	n.d.	0.2	n.d.		0.13	0.14	0.14		
P <sub>2</sub> O <sub>5</sub>	0.03	0.08		0.14	0.12	0.022	0.19	0.03	0.02	0.02	+	0.12
MnO	1.3	1.07	1.30	0.40	n.d.	0.51	0.4	0.40	0.30	0.37	0.37	0.8
MgO	0.22	0.27	0.85	0.40	n.d.	0.64	0.79	0.75	0.80	0.64	0.85	0.48
CaO	0.01	0.02	0.02	n.d.	n.d.	0.04	0.00	0.08	0.12	0.08	0.08	n.d.
ZrO <sub>2</sub>		0.23	0.12	0.20	0.06	n.d.		<0.01	<0.01	<0.01	0.02	0.3
SiO <sub>2</sub>	0.55	0.77	0.44	0.75	1.5	0.71	0.83	0.30	0.70	0.50	1.51	1.8
Zn								410 ppm	545 ppm	450 ppm		
Pb								70 ppm	35 ppm	40 ppm		
U	3 ppm		<10 ppm	~10 ppm	200 ppm	<6 ppm		<10 ppm	<10 ppm	<10 ppm		60 ppm
Th	60 ppm		<10 ppm	~160 ppm		~43 ppm		50 ppm	20 ppm	20 ppm		
LOI			~0.12				0.98	>2.50	>3.50	>3.30		0.1

Figure 46: Indicative chemical composition of ilmenite concentrates<sup>62</sup>

	Trail Ridge Du Pont Florida, USA	Green Cove Springs Iluka Resources Ltd. Florida, USA	Jacksonville Humphrey's Gold Corp. Florida, USA	Folkston Humphrey's Gold Corp. Georgia, USA	Sai Lao Processing Plant Hainan Island Guangdong Province, China	Beihai Processing Plant Fuxi Ilmenite Guangxi Province, China	Beihai Processing Plant Beach Ilmenite Guangxi Province, China	Beihai Processing Plant Tiomin Resources Inc. Kenya	Kwale Central Trial Product Tiomin Resources Inc. Kenya	Pooncarie Project Chloride Ilmenite Murray Basin NSW, Australia	Egypt Nile delta	Madagascar	Aluhassa Oil Sands
<b>Typical</b>													
TiO <sub>2</sub>	64.89	63.67	62.95	59.78	51.48	53.50	55.04	48.90	64.5	52.51	61.47	64.3	
Fe (total)						32.89	29.17						
FeO					33.99	37.15	23.80						
Fe <sub>2</sub> O <sub>3</sub>	28.27	28.94	30.44	31.77		5.75	15.25	51.46	32.5	43.82	32.62	29.5	
Cr <sub>2</sub> O <sub>3</sub>	0.06	0.09	0.09	0.11		0.045	0.047	0.09	0.14	0.22	0.05	0.13	
Al <sub>2</sub> O <sub>3</sub>	1.48	1.43	1.32	1.82	0.75	0.42	0.73	0.31	0.74	0.34	0.79	1.2	
V <sub>2</sub> O <sub>5</sub>	0.14	0.14	0.14	0.13		0.14	0.11	0.21	0.25	0.29	0.15	0.14	
Nb <sub>2</sub> O <sub>5</sub>	0.19	0.20	0.21	0.22	0.039	0.16	0.18		0.09	0.09	0.26		
P <sub>2</sub> O <sub>5</sub>	0.17	0.19	0.16	0.34	0.018	0.032	0.070	0.09	0.12	0.10	0.07	0.36	
MnO	1.02	1.19	1.38	1.48	1.46	1.50	1.55	0.65	0.94	0.82	0.37	0.20	
MgO	0.31	0.30	0.27	0.34	0.12	0.10	0.10	0.76	0.86	0.81	0.48	0.2	
CaO	0.07	0.17	0.06	0.36	0.31	0.044	0.057	0.04	0.06	0.09	0.02	0.1	
Zr(Hf)O <sub>2</sub>	0.04	0.05	0.13	0.21	0.14	0.20	0.43	<0.01	0.09	0.13	0.18	0.45	
SiO <sub>2</sub>	0.05	0.19	0.10	0.84	0.79	0.71	1.44		0.60	0.85	0.24	1.9	
Zn	232 ppm	213 ppm	241 ppm	304 ppm		300 ppm	360 ppm			205 ppm	359 ppm		
Pb	219 ppm	224 ppm	140 ppm	129 ppm		67 ppm	95 ppm			88 ppm	162 ppm		
U	<5 ppm	<5 ppm	<5 ppm	32 ppm				<0.5 ppm	<10 ppm	8 ppm	14 ppm	40 ppm	
Th	53 ppm	114 ppm	71 ppm	215 ppm				30 ppm	72 ppm	40 ppm	103 ppm	80 ppm	
LOI	2.67	2.56	2.09	1.59					0.92	-0.46	2.90		

Figure 47: Indicative chemical composition of ilmenite concentrates<sup>63</sup>

<sup>62</sup> Elsner (2010).

<sup>63</sup> Elsner (2010).

DC Smelting Technology

Developed by Anglo-American in the late 1990's, the DC (plasma arc) smelting technology is used for the production of titanium slag at the Namakwa Sands smelter (now owned by Tronox) on the west coast of South Africa. A variant of the same technology developed independently by Exxaro (now Tronox), is now also used at Tronox's KZN sands operation in Empangeni, KwaZulu-Natal. The DC process can be operated with smaller furnace sizes than AC smelting, which can provide some economic advantage at lower capacities (Gilman & Taylor, 2001) (Jones, Curr, & Barcza, 1993).

Element	Sulphate slag		Chloride slag		
	Sorel (weight per cent)	Tinfos (weight per cent)	RBM (weight per cent)	Namakwa (weight per cent)	UGS (weight per cent)
TiO <sub>2</sub>	80	77	85.5	86.0	95.0
Fe <sub>2</sub> O <sub>3</sub>	9	-	-	-	-
FeO	-	8	10.8	9	1.17
SiO <sub>2</sub>	2.4	4.5	2.1	1.8	1.95
MgO	5.0	6.0	1.1	0.7	0.6
Al <sub>2</sub> O <sub>3</sub>	2.9	1.7	1.3	1.4	0.60
Cr <sub>2</sub> O <sub>3</sub>	0.17	0.12	0.17	0.09	0.03
U +Th ppm	<5	-	15 - 30	20	<5

Figure 48: Typical slag chemical compositions are shown in the table below<sup>64</sup>

Country Occurrence	Properties of the material	Properties slag	Capacity production
Canada Allard Lake	Ilmenite-hematite-ore (on average 34.3 % TiO <sub>2</sub> , 27.5 % FeO, 25.2 % Fe <sub>2</sub> O <sub>3</sub> )	Sorel slag (on average 80 % TiO <sub>2</sub> , 8 % FeO) "upgraded slag" (UGS) (on average 94.5 % TiO <sub>2</sub> , 1 % Fe <sub>2</sub> O <sub>3</sub> )	1.1 Mt/year 1.01 Mt (2007)
Rep. of South Africa Richards Bay	Placer ilmenite (on average 49.7 % TiO <sub>2</sub> , 36.6 % FeO, 11.1 % Fe <sub>2</sub> O <sub>3</sub> )	RBM-slag (on average 85% TiO <sub>2</sub> , 12 % FeO)	1.05 Mt/year n.a.
Rep. of South Africa Namakwa	Placer ilmenite (on average 52 % TiO <sub>2</sub> )	Namakwa-slag (on average 86 % TiO <sub>2</sub> , 10 % FeO)	200,000 t/year 159,000 t (2008)
Rep. of South Africa Hillendale	Placer ilmenite (on average 46.6 % TiO <sub>2</sub> )	KZN-slag (on average 86 % TiO <sub>2</sub> , 12 % FeO)	250,000 t/year 113,000 t (2008)
Norway Tellnes	Titanium magnetite ore (on average 44.4 % TiO <sub>2</sub> , 34.0 % FeO, 12.5 % Fe <sub>2</sub> O <sub>3</sub> )	Tinfos slag (on average 75 % TiO <sub>2</sub> )	240,000 t/year n.a.

Figure 49: Major titanium slag operations<sup>65</sup>

<sup>64</sup> Gilman & Taylor (2001).

<sup>65</sup> Elsner (2010).

The existing ilmenite smelting technologies do not remove impurities, other than iron, present in the ilmenite. Rio Tinto Fer et Titane (RTFT) Canada uses a proprietary process to reduce the SiO<sub>2</sub>, MgO and CaO contents of the standard Sorel slag for the production of upgraded slag (UGS). This is done by grinding and sizing the slag, followed by heating to produce heat-treated slag (HTS) to aid the subsequent leaching of the impurities. Leaching is carried out with hydrochloric acid and results in a product containing 92- 95% TiO<sub>2</sub> (Gilman & Taylor, 2001). This upgraded slag is used as a feedstock in chloride pigment. Removal of the MgO and CaO is critical to creating a product suitable for use in the North American chloride pigment plants.

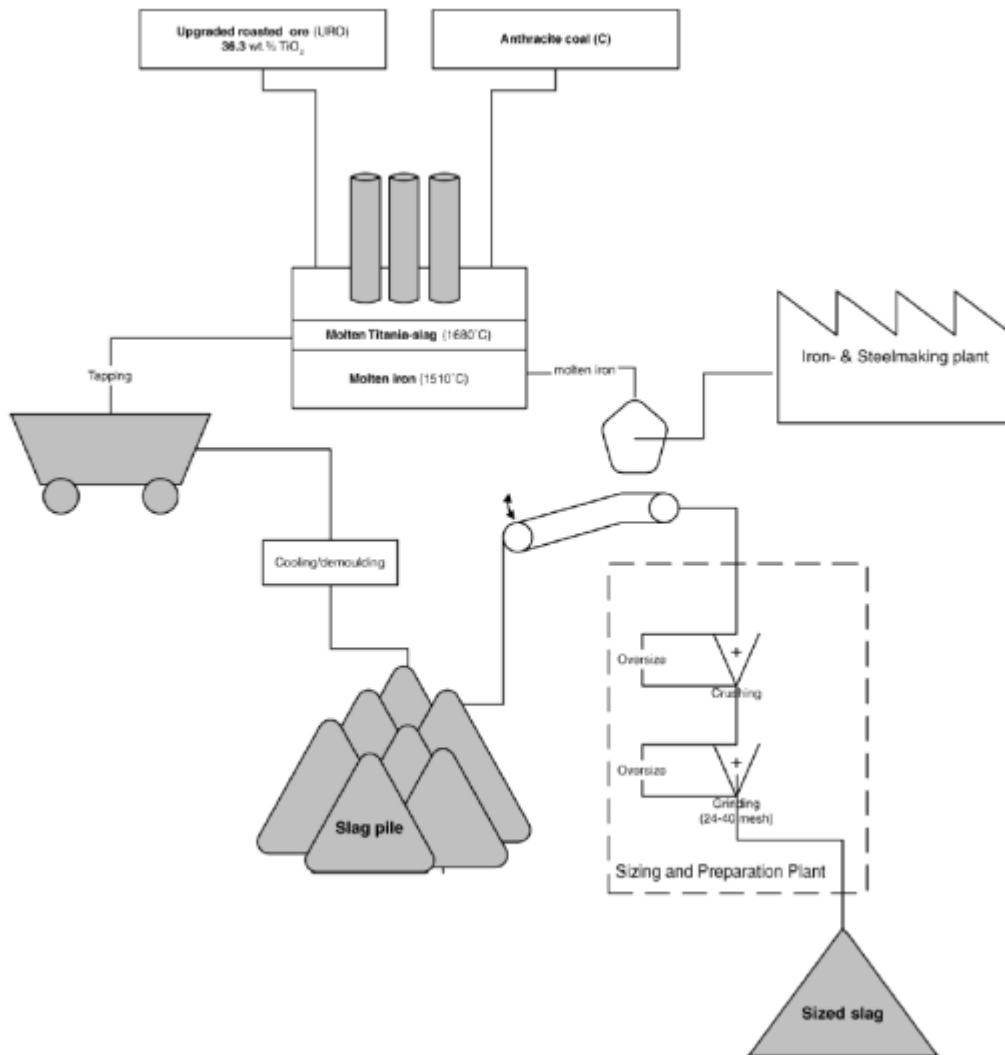

Figure 50: Titania slag EAF AC smelting process at Rio Tinto Fer et Titane (RTFT) at Sorel, Canada<sup>66</sup>

<sup>66</sup> Cardarelli & Guéguin (2007).

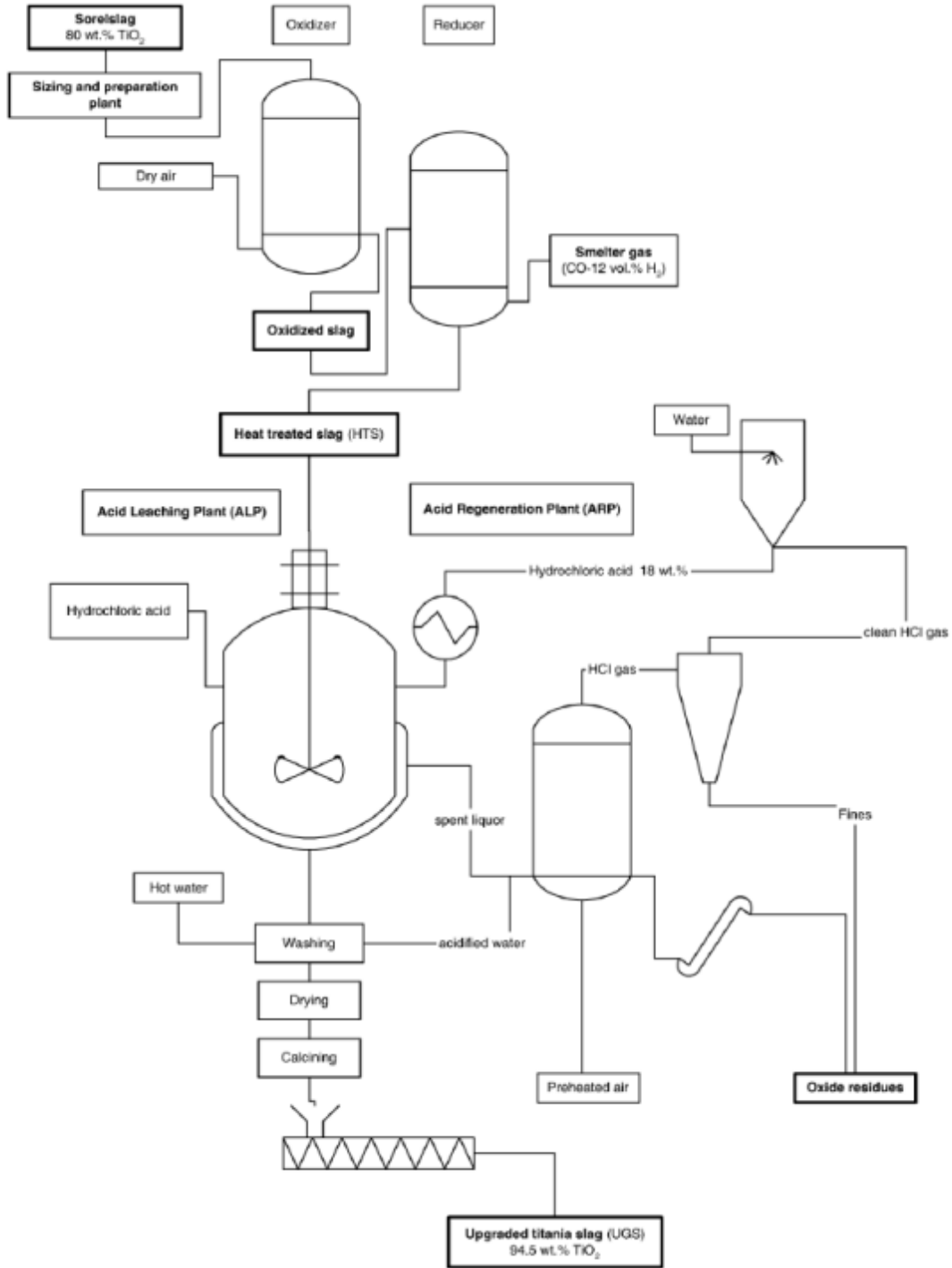

Figure 51: Upgraded titania slag process (UGS) at Rio Tinto Fer et Titane (RTFT) at Sorel, Canada<sup>67</sup>

<sup>67</sup> Cardarelli & Guéguin (2007).

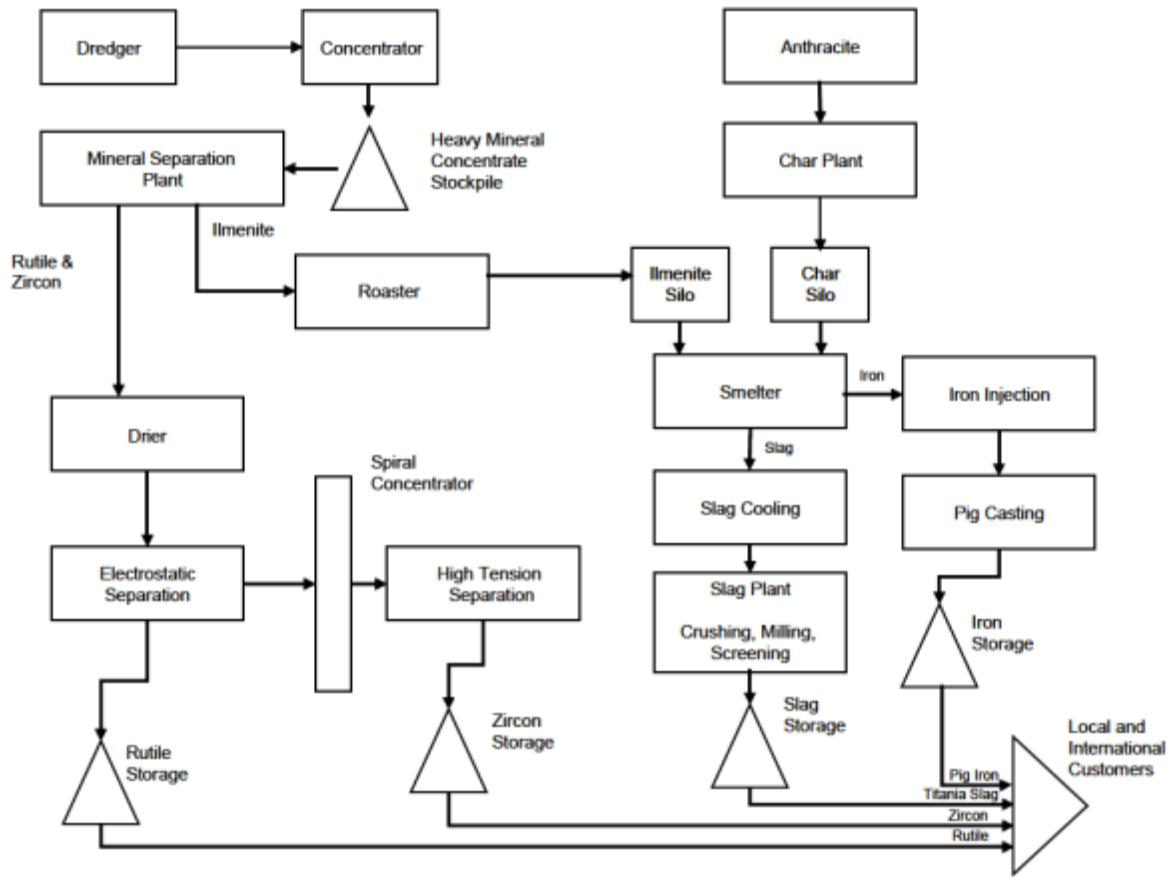

Figure 52: An overview of the production of Titania slag (AC Smelting), high purity pig iron, rutile and zircon at Rio Tinto's Richards Bay Minerals in South Africa<sup>68</sup>

<sup>68</sup> Williams & Steenkamp (2006).

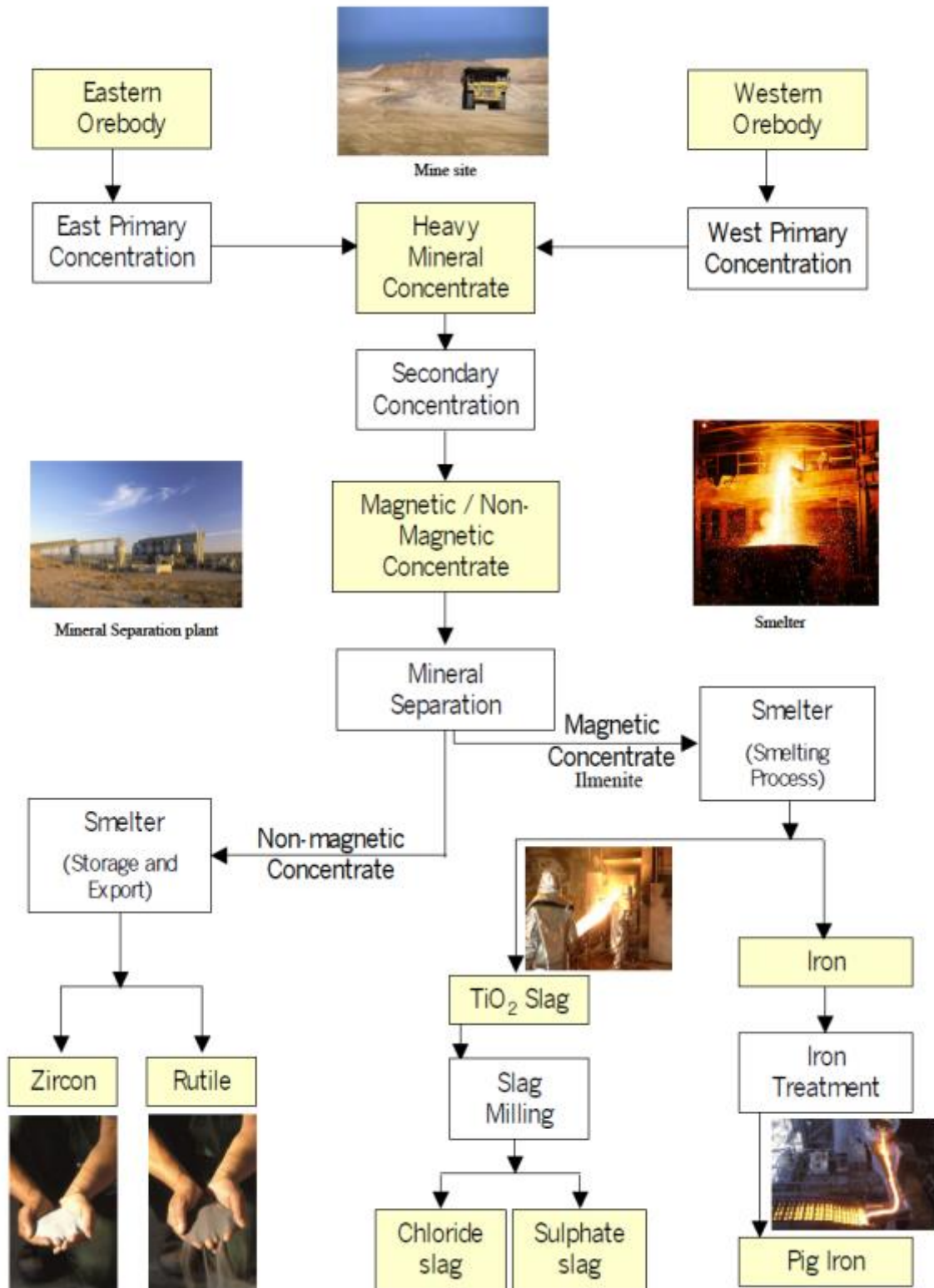

Figure 53: An overview of the production of Titania slag (DC Smelting), high purity pig iron, rutile and zircon Tronox's Namakwa Sands in South Africa<sup>69</sup>

<sup>69</sup> Gous (2006).

Production of chloride-grade titanium feedstock and high purity pig iron from low-grade ilmenite ores from Minnesota and New York by smelting and sulfation leaching

The US Bureau of Mines (USBM) conducted both laboratory and pilot plant scale to produce chlorination-grade feedstock from an abundant, low-grade, domestic, rock ilmenite ore. The research was part of an effort to devise technology that may help decrease US dependence on imported raw materials (see U.S. imports for consumption of titanium feedstocks, by country below).

A rock ilmenite concentrates from New York and Minnesota containing about 46-47 %  $\text{TiO}_2$  was smelted in an electric arc furnace with coke, woodchips, and soda ash to separate the iron as pig iron and to form a low-iron, titanium-enriched slag. The slag was ground, pelletized, oxidized, and then sulfated with mixtures of  $\text{SO}_2$  and air at  $750^\circ\text{C}$  to  $950^\circ\text{C}$ . The sulfated slag, containing 60% to 77%  $\text{TiO}_2$ , was reground and leached in water or dilute HCl at ambient temperature to decrease the combined levels of the troublesome calcium, magnesium, and manganese impurities to less than 1.7 wt %. The final product was upgraded to about 84-94 wt %  $\text{TiO}_2$  (Wright, Elger, Tress, & Bell, 1985) (Nafziger & Elger, 1987). The slag upgraded in the pilot plant investigation was essentially equal in grade to the Richards Bay slag or Sorel slag made commercially from ilmenite concentrate in the Republic of South Africa and Canada, respectively.

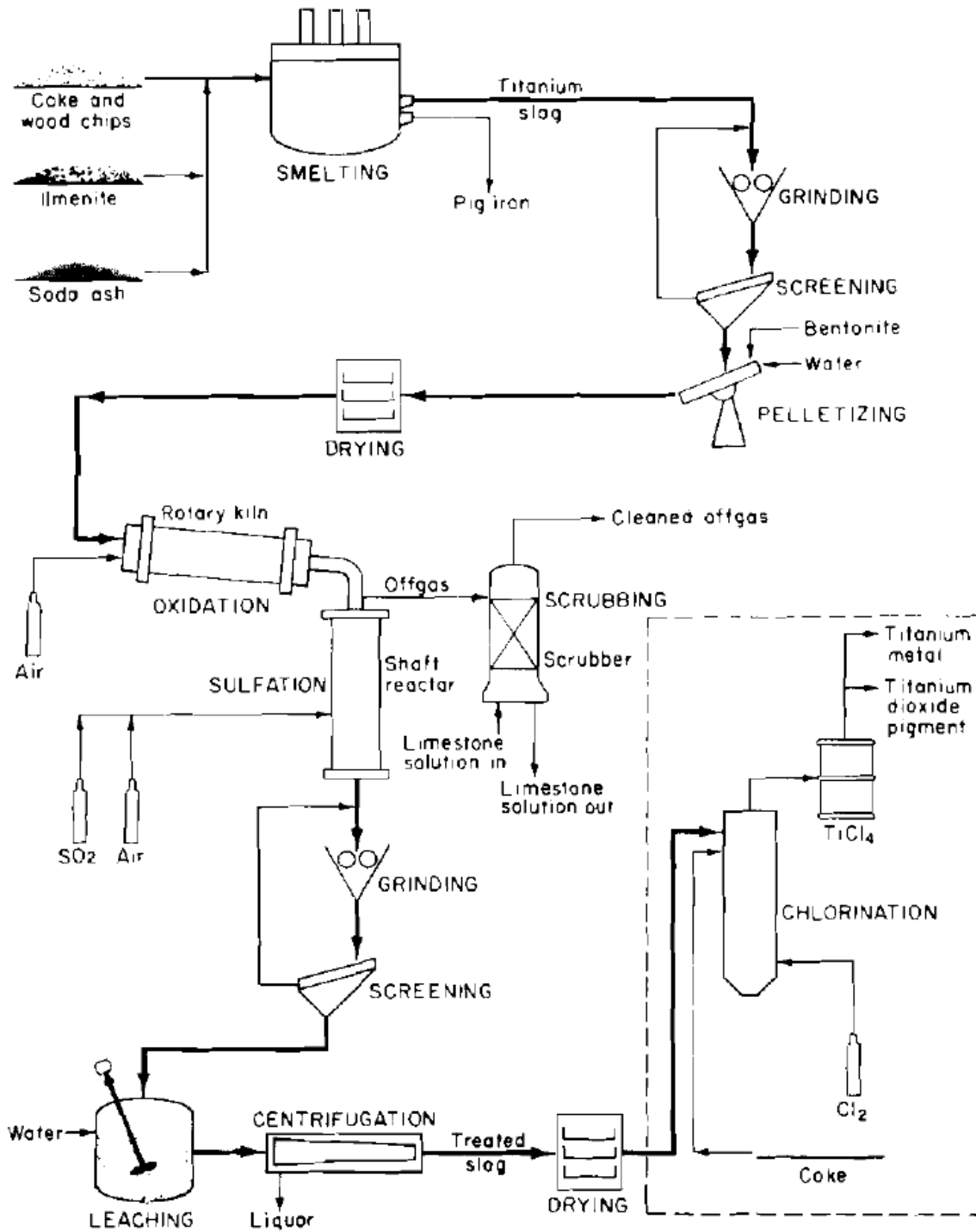

Figure 54: Process flow diagram for Bureau of Mines ilmenite conversion scheme<sup>70</sup>

<sup>70</sup> Wright, Elger, Tress, & Bell (1985).

### ***Market Specifications for Beneficiated Titanium Feedstock***

Typical factors influencing the suitability of titanium feedstock to sulfate and chloride processes are listed below:

For the sulfate process, the  $\text{Cr}_2\text{O}_3$  content must be relatively low. The titanium should be in a form, which is readily acid, soluble. During the production of titanium slag by smelting, a portion of the  $\text{TiO}_2$  undergoes a phase transformation to a rutile phase, which has poor solubility in sulfuric acid, and thus, for sulfate process use, the formation of the rutile phase must be minimized (Gilman & Taylor, 2001) (Elsner, 2010) (Zhang, Zhu, & Cheng, 2011).

For the chloride process, the particle size is a critical factor; a narrow particle size spectrum is advantageous because this avoids blow over effects during chlorination in the reactor and dust losses. During the production of titanium slag, the slag product is crushed, milled and sized. The slag producers aim to minimize the proportion of fines generation. For chloride feedstocks, the alkali content should be  $<0.2\%$  CaO,  $<1\%$  MgO as they have a tendency to form liquid chlorides at  $1000\text{ }^\circ\text{C}$  and impede the distillation of the titanium tetrachloride. The iron content should be low else; it leads to the formation of iron chloride, which melts at  $700\text{ }^\circ\text{C}$  and blocks the lines. In addition,  $\text{Cr}_2\text{O}_3$  and  $\text{V}_2\text{O}_5$  should be  $<0.5\%$  as these compounds influence the color of the white pigment, and could form toxic waste materials and form liquid chlorides that clog the reactor bed. The Sn and As usually accumulate with the titanium tetrachloride,  $<2\%$   $\text{SiO}_2$  normally coats grains and hinders the chlorination reaction. Finally, U, Th and Ra contents of  $<500\text{ ppm}$  in total to minimize the amount of radioactivity in various process streams and equipment (Elsner, 2010) (Gilman & Taylor, 2001) (Zhang, Zhu, & Cheng, 2011).

Attribute	Sulfate	Chloride
Particle size	Not critical	Fines (usually $<100\text{ }\mu\text{m}$ ) blown out of fluid bed
Fe	Requires high ferrous content to get high reactivity	Not critical
$\text{TiO}_2$	Not critical, in ilmenites, need for high FeO leads to $\text{TiO}_2$ lower than 55 per cent	In theory not critical, cost considerations drives to higher $\text{TiO}_2$ ; only one operator commercially treats ilmenite in chloride route
Cr	Low levels required as it follows $\text{TiO}_2$ and spoils pigment colour	Goes to waste and can cause waste disposal constraints
Ca and Mg	Not critical	Causes loss of fluidity in reactor

Figure 55: Typical feed requirements for pigment plants<sup>71</sup>

### ***Commercial Processes for the Production of Titanium Dioxide***

Currently, there are two commercial processes for the production of pigment-grade titanium dioxide: the sulfate process, involving the digestion of the feedstock in sulfuric acid, and the chloride process, which is based on chlorination in fluidized bed reactors. The sulfate and chloride process has been reviewed in detail by V. I. Lakshmanan et al. (Lakshmanan, Roy, & Halim, 2016).

<sup>71</sup> McManus (2013).

### The Sulfate Process

The feed (ilmenite ore or synthetic titanium slag) is dried and ground before being digested by sulfuric acid, generally at an acid strength of 85-92% and at temperatures of 150-180°C, yielding a solution of titanyl and ferrous sulfates. The majority of the ferrous sulfate is crystallized out and discarded as wastes. The titanium is hydrolyzed by boiling, yielding hydrated titanium dioxide, which is then calcined. The sulfate plants use certain proprietary nuclei at the precipitation and calcination stage process to yield the product in either the anatase or the rutile crystal modification (Lakshmanan, Roy, & Halim, 2016).

For each ton of TiO<sub>2</sub> produced using the sulfate process, approx. 2.7 tons of ilmenite (45 % TiO<sub>2</sub>) and 4.0 tons of sulfuric acid, or 1.4 tons of titanium slag (80 % TiO<sub>2</sub>) and 2.3 -3.0 tons of sulfuric acid are required. In addition to 0.6 -2.7 tons of iron sulfate, around 6- 8 tons of sulfuric acid are produced (Elsner, 2010).

Sulfate pigment plants using ilmenite, generate large quantities of waste in the form of copperas (ferrous sulfate heptahydrate) and neutralized spent acids. Most sulfate plants have developed processes for the recovery of sulfuric acid from the waste, neutralization of effluent, and recovery of byproducts. While the use of slag as a feedstock significantly reduces the volume of waste generated, it does make the process harder to control due to the presence of less acid soluble rutile phase in the slag (Gilman & Taylor, 2001) (Elsner, 2010).

### The Chloride Process

Most chloride processes use high TiO<sub>2</sub> feedstocks –upgraded slag (UGS) or synthetic rutile, and rutile. The titanium feedstocks are mixed with high-purity coke and chlorinated at 850-1,200°C in a fluidized bed reactor. The reaction produces volatile titanium tetrachloride (TiCl<sub>4</sub>) and chlorides of iron and other impurities. Subsequently, it is cooled to condense the bulk of the low volatile chlorides, including iron, manganese, and chromium. The TiCl<sub>4</sub> is then condensed and further purified by organic chemical treatment and distillation. TiCl<sub>4</sub> is reacted with oxygen at 900–1400 °C to form TiO<sub>2</sub> and chlorine gas to form solid TiO<sub>2</sub> particles, and chlorine is liberated and recycled to the chlorinator (Lakshmanan, Roy, & Halim, 2016).

The manufacture of one ton of TiO<sub>2</sub> using the chloride process requires approx. 1.0-1.1 tons of rutile, 0.1-0.2 tons of chlorine, 0.1- 0.3 tons of coke and 0.45- 0.5 tons of oxygen. In this process, approx. 0.4-0.9 tons of iron chloride are produced as a by-product. The chloride plants using low TiO<sub>2</sub> feedstock, the chlorine requirement increases up to 0.7-0.9 tons and generates a higher amount of iron chloride (Elsner, 2010).

All the pigment plants in the USA use this process.

Process	Feed	Product	Advantage	Disadvantage
Traditional sulphate leaching process	Natural ilmenite (>44 TiO <sub>2</sub> ) Ti slag (78% TiO <sub>2</sub> )	Anatase (>98% TiO <sub>2</sub> ) (for papers, ceramics and inks)	Processing low grade ilmenite; low capital cost; low energy consumption; simple technology	High H <sub>2</sub> SO <sub>4</sub> consumption; large iron sulphate waste and dilute H <sub>2</sub> SO <sub>4</sub> production
BHP Billiton improved sulphate process	Diverse ilmenite ores; Fe scrap reductant	>99% TiO <sub>2</sub> with solvent extraction; >97% with crystallisation	Reduced waste; producing clean gypsum; better selectivity by SX to produce purer products	Increased process complexity Recycling large volume of dilute acid solution
Thermo chloride processes	>90% TiO <sub>2</sub> natural or synthetic rutile or high grade Ti slag	Pigment grade products (>99.5% TiO <sub>2</sub> ); Ti metal	Recycle use of HCl reagent Suitable for larger scale Purer products Waste more environmentally acceptable	Need for higher grade feed; more corrosive high energy consumption; complicated technology
Chloride leaching process	Natural ilmenite and Ti slag	>99.5% TiO <sub>2</sub>	More complete HCl acid recycle; lower cost for waste and more environmental acceptable; higher purity products	Higher capital costs for equipment and construction; higher requirement for operation and maintenance skill
Caustic process	Natural ilmenite and Ti slag	>99.3% TiO <sub>2</sub>	Higher leaching selectivity for Ti over Fe; mild leach conditions at low temperature and atmosphere	Need for transformation of titanate to hydrous TiO <sub>2</sub> in acidic solution; recycling of large amount of KOH solution and energy consumption

Figure 56: Comparison of sulfate processes with chloride processes<sup>72</sup>

### *Extracting Titanium Metal from Ore*

Titanium feedstocks are subjected to chlorination to produce titanium tetrachloride and then reduced with magnesium (Kroll process) to yield titanium sponge. The Kroll process has four major steps:

- First, rutile concentrate or synthetic rutile (titanium slag) is chlorinated to form titanium tetrachloride and then distilled to remove metallic impurities such as iron, chromium, nickel, magnesium, and manganese.
- Second, the titanium tetrachloride is reduced with magnesium.
- Third, the remaining magnesium and magnesium chloride are removed by vacuum distillation. In this technique, heat is applied to the sponge mass while a vacuum is maintained in the chamber, causing the residue to boil off from the sponge mass. At the end of the process, the residual magnesium chloride is separated and recycled.
- Finally, the sponge mass is mechanically pushed out of the distillation vessel, sheared, and crushed.

Titanium sponge produced by metallic reduction processes contains significant quantities of impurities, which are subsequently removed by leaching, vacuum arc re-melting, and cold hearth techniques. Several stages of re-melting may be required to produce progressively purer titanium metal. The final product of this purification process is known as titanium ingot. Titanium ingot is fabricated into mill, which are used for metal casting, the production of fabricated products, or as feedstock for the production of titanium alloys (Younossi, Seong, Goldsmith, Lang, & Neumann, 2009).

### *Non-Commercial Process for the Production of Synthetic Rutile*

#### Musro [Murphy ores, CSIRO]

In this process, ilmenite is beneficiated by a combination of oxidation, reduction, and pressure leaching with hydrochloric acid. The process was developed by Murphyores Pty and the

<sup>72</sup> Zhang, Zhu, & Cheng (2011).

Commonwealth Scientific and Industrial Research Organization (CSIRO) in 1967 (Comyns, 2014).

### SRET

A two-stage process for making synthetic rutile from ilmenite, developed in Australia by Iluka Resources. The first stage is a pyrometallurgical process, in which the ilmenite is reduced in a rotary kiln in the presence of a reductant. The second stage is hydrometallurgical, in which the iron is removed by oxidation and leaching. The final product contains between 88% and 95% of TiO<sub>2</sub> (Comyns, 2014).

### TSR (Tiomin Synthetic Rutile)

A process for rejecting iron from ilmenite in order to make a feedstock for titanium pigment manufacture was developed by Tiomin Resources, Canada, in the 1990s. The ore is successively oxidized and reduced in fluidized beds and then leached with hydrochloric acid. The product contains approximately 95% of titanium dioxide (Comyns, 2014).

### Wendell Dunn

The process was designed by W.E. Dunn of Chlorine Technology in Australia in the 1970s. It is based on selective chlorination of ores in a fluidized bed. The entire process, including recovery of chlorine by oxidizing the ferrous chloride, was piloted by Heubach in Ankleshwar, India, in 2001, the process being called the Reptile Process and the product being called Reptile 96 (Replacement rutile containing 96% rutile) (Comyns, 2014).

Process	Pyro-treatment	Leaching	Advantage	Disadvantages
The Becher sulphate process	Iron oxidised to Fe <sub>2</sub> O <sub>3</sub> and reduced to metallic Fe by at 1200 °C	(a) NH <sub>4</sub> Cl/O <sub>2</sub> (b) 0.5 M H <sub>2</sub> SO <sub>4</sub>	Allowing diverse ilmenite ores feed	Multi step iron conversions and leaching High energy consumption Emission of CO <sub>2</sub>
The Murso process	Similar to the Becher process, but fluidised beds for the conversion	20% HCl	Improved efficiency by using fluidised beds Easier HCl recycle than sulphate system	Similar to the Becher processes
The Laporte process	Lower temperatures for iron conversion to FeO with controlled CO <sub>2</sub> pressure	18% HCl with a bed contactor	Free of formation of fine TiO <sub>2</sub> particles Ease for leaching FeO	Similar to the Becher processes in spite of lower temperature used
The Benelite process	Iron conversion to Fe(II) forms by carbon thermo-reduction	18-20% HCl	Simple one step conversion of iron	Limited ilmenite types as the feed
The Austpac process	Magnetisation of the ilmenite at 800-1000 °C	25% (w/w) HCl	Magnetic separation for higher >97% TiO <sub>2</sub>	Higher acidity need for leaching remaining magnetic iron form
The Dunn process	Selective chlorination of iron in ilmenite with Cl <sub>2</sub>	-	Cl <sub>2</sub> recycle by oxidation of FeCl <sub>2</sub> to Fe <sub>2</sub> O <sub>3</sub>	Handling highly corrosive Cl <sub>2</sub>
The Kataoka process (in Japan)	Conversion to ferrous form	H <sub>2</sub> SO <sub>4</sub>	Less corrosive using H <sub>2</sub> SO <sub>4</sub> than HCl Low leaching temperature	Produce large iron sulphate wastes

Figure 57: Summary of processes for upgrading ilmenite to synthetic rutile<sup>73</sup>

### ***Non-Commercial Processes for the Production Titanium Dioxide Pigment***

A number of alternative pigment processes that have been under development. To date, none of these has been able to break through into commercial production.

<sup>73</sup> Zhang, Zhu, & Cheng (2011).

### Altair process

A method for producing nanoparticulate TiO<sub>2</sub> pigment directly from an ilmenite feedstock was developed by BHP Billiton in Reno, Nevada. In November 1999, Altair International Inc., now Altair Nanotechnologies Inc. (Altair) acquired BHPB's patents and inventions relating to the new process (Ellsworth, Verhulst, Spitler, & Sabacky, 2000).

The process involves digestion of ilmenite feedstock in concentrated hydrochloric acid; titanium is extracted using solvent extraction in a purified stream, and spray hydrolysis to produce a TiO<sub>2</sub> hydrate. This is followed by final calcining and milling. The HCl used to leach the ore is recycled, leaving the metallic impurities—predominately iron—as metal oxides that are suitable for sale or use as landfill (Ellsworth, Verhulst, Spitler, & Sabacky, 2000).

### ***Global Sources of Titanium Feedstock***

Most mineral sands are concentrations of heavy minerals in an alluvial, shorelines or river system environment. Alluvial deposits have been commercially mined in Australia, South Africa, India, Sri Lanka, Madagascar, Vietnam, Sierra Leone, Mozambique the US, and Ukraine. There are hard-rock ilmenite mines in Canada, China, Russia, Finland, and Norway. China is the largest producer of ilmenite globally; the primary source of ilmenite is the Panzhihua titaniferous magnetite deposit in Sichuan Province, for many years the main source of ilmenite for TiO<sub>2</sub> pigment production in China. South Africa is the world's second-largest ilmenite producer with extensive resources. The most important occur on the coast of Richards Bay in KwaZulu-Natal. Most of the South African ilmenite is smelted to produce titanium slag. Canada is the world's third-largest producer of ilmenite. Its primary resource is the Lac Allard deposit in Quebec currently being mined by Rio Tinto Fer et Titane (RTFT) for the production of high titania slag.

Norway's ilmenite resources are contained in primary rock deposits, the most significant the Tellnes orebody in the south, which is currently being mined to produce sulfate-grade ilmenite. Large deposits of ilmenite in Ukraine have been mined at Irshansk and Vilnohirsk, primarily to provide titanium feedstock for sulfate pigment production in the nearby region and titanium sponge production in both Ukraine and Russia.

Most mineral sand mines in the US are predominantly coastal-type sedimentary deposits on the Atlantic coastal plain, with mines operating in Virginia and Florida. Titanomagnetite deposits are mainly located in New Zealand, Japan, Taberg/Sweden, Otanmaki/Finland and Bushveld/South Africa (Elsner, 2010).

### ***Global Mineral Sand Operations***

Rio Tinto is the world's biggest titanium feedstock producer with operations in Fer et Titane in Canada, Richards Bay Minerals (RBM) in South Africa and QMM Madagascar. Tronox Ltd is the world's second-largest feedstock producer. Tronox operates Namakwa Sands and KZN Sands in South Africa, and the operation formerly known as Tiwest in Western Australia. The third leading feedstock producer is Australia-based Iluka Resources with operations in Western Australia, South Australia, and Victoria as well as the US State of Virginia. Kronos

Worldwide Inc. (Kronos) owns Titania AS, which mines rock ilmenite at Tellnes in Norway to feed its European sulfate-route pigment plants (Dujardin & Fourcade, 2011).

Operation (major owner for multiple operations)	Location	Deposit style, mining method	Ilmenite upgraded – slag or SR	Final products
Iluka Australia	Australia	Sand, dry mining	Yes – SR <sup>2</sup>	Zircon, rutile, SR
Iluka Virginia	US	Sand, dry mining	No	Chloride ilmenite, zircon
RBM (Rio Tinto)	South Africa	Sand, dredge	Yes – slag	Zircon, chloride slag
QIT (Rio Tinto)	Canada	Hard rock, dry mining	Yes – slag	Sulphate slag, upgraded slag, chloride slag (from QMM ilmenite)
QMM (Rio Tinto)	Madagascar	Sand, dredge	Yes – slag at QIT	Zircon, chloride slag (from QIT)
Namakwa Sands (Tronox)	South Africa	Sand, dry mining	Yes – slag	Chloride slag, sulphate slag, zircon
KZN Sands (Tronox)	South Africa	Sand, hydraulic	Yes – slag	Chloride slag, sulphate slag, zircon
Twist (Tronox)	Australia	Sand, dredge	Yes – SR	Zircon, rutile, SR
Kenmare Resources	Mozambique	Sand, dredge	No	Chloride and sulphate ilmenite, zircon
Sierra Rutile	Sierra Leone	Sand, dredge and dry mining	No	Rutile, chloride ilmenite
Vilnohirsk and Irshansky (Ostchem)	Ukraine	Hard rock, dry mining	No	Sulphate and chloride ilmenite, rutile, zircon

Figure 58: Some of the major titanium feedstock producers<sup>74</sup>

<sup>74</sup> Iluka Resources (2014)

Raw material	TiO <sub>2</sub> (%)	Use
Ilmenite-concentrate of ilmenite/magnetite or ilmenite/hematite rock, e. g. Tellnes/Norway, Allard Lake/Quebec	44-45	Sulfate process or titanium melt
Ilmenite in beach placers, e. g. east and west coast of Australia, Florida, India and Sri Lanka	48-51	Refractory industry, sulfate process, production of synthetic rutile
Ilmenite from placers, e.g. Australia, USA, India, Sri Lanka, Ukraine and Malaysia (tin production)	54-60	Sulfate process, production of synthetic rutile
Weathered ilmenite from placers, e. g. Eneabba, Western Australia, Green Cove Springs, Florida	≥60	Sulfate process, production of synthetic rutile
Leucoxene, e. g. Bunbury/Capel area, Western Australia and Florida	≥68	Chloride process and welding rods
Titanium slag from Quebec by melting ilmenite/hematite rocks	75-80	Sulfate process
Titanium slag through melting ilmenite from Richards Bay, Rep. of South Africa	85	Sulfate and chloride process
Anatase concentrate from carbonatites in Minas Gerais/Brazil	90	Chloride process
<i>Upgraded Slag</i> (UGS) from Quebec through melting and concentrating ilmenite/hematite rocks	95	Chloride process
Synthetic rutile through reduction of iron and chemical leaching of ilmenite, mostly from the USA, Australia, Japan, Taiwan and India	92-95	Chloride process
Natural rutile from placers, e. g. from Australia, Sierra Leone, Rep. of South Africa, Ukraine, Sri Lanka, India	94-96	Chloride process, welding rods and coatings, titanium metal

Figure 59: Suitability of titanium raw materials as a function of their TiO<sub>2</sub> content<sup>75</sup><sup>75</sup> Elsner (2010).

Concentrate and country	HTS <sup>2</sup> code	2013		2014	
		Quantity (metric tons)	Value (thousands)	Quantity (metric tons)	Value (thousands)
<b>Ilmenite:</b>	<b>2614.00.6020</b>				
Australia		189,000	\$51,700	118,000	\$19,800
Mozambique		167,000	34,100	217,000	38,600
Senegal		--	--	20,100	2,610
Other		33,800	4,880	137	62
<b>Total</b>		<b>389,000</b>	<b>90,600</b>	<b>355,000</b>	<b>61,100</b>
<b>Titaniferous slag:</b>	<b>2620.99.5000</b>				
Australia		--	--	108,000	63,300
Canada		222,000	119,000	213,000	162,000
Madagascar		--	--	26,600	5,640
South Africa		459,000	342,000	331,000	225,000
Other		-- <sup>r</sup>	-- <sup>r</sup>	4	8
<b>Total</b>		<b>681,000<sup>r</sup></b>	<b>461,000<sup>r</sup></b>	<b>678,000</b>	<b>455,000</b>
<b>Rutile, natural:</b>	<b>2614.00.6040</b>				
Australia		94,800	66,100	64,100	47,300
Canada		12,000	15,600	--	--
Kenya		--	--	16,800	15,600
Sierra Leone		42,900	26,600	20,200	16,200
South Africa		118,000	145,000	144,000	109,000
Ukraine		11,300	14,800	10,200	7,710
Other <sup>3</sup>		121 <sup>r</sup>	320 <sup>r</sup>	295	378
<b>Total</b>		<b>279,000</b>	<b>269,000</b>	<b>255,000</b>	<b>196,000</b>
<b>Rutile, synthetic:</b>	<b>2614.00.3000</b>				
Australia		124,000	163,000	84,400	66,400
Malaysia		2,420	4,200	2,790	4,030
Other <sup>3</sup>		72 <sup>r</sup>	138 <sup>r</sup>	304	514
<b>Total</b>		<b>127,000</b>	<b>167,000</b>	<b>87,500</b>	<b>71,000</b>
<b>Titaniferous iron ore, Canada<sup>4</sup></b>	<b>2614.00.6020</b>	<b>13,800</b>	<b>1,460</b>	<b>138</b>	<b>62</b>

Figure 60: U.S. Imports for Consumption of Titanium Concentrates, by Country<sup>76</sup>

### Major Global Pigment Producers

The world's biggest pigment producer – The Chemours Company (spin off from DuPont) – is also a feedstock producer with a mineral sands mining operation in Florida, US. Chemours operates the two largest pigment plants (chloride process) in the world, at DeLisle, Mississippi and New Johnsonville, Tennessee. The company also owns plants in Edge Moor, Delaware, Kuan Yin, Taiwan, and Altamira, Mexico (The Chemours Company, 2017). Huntsman is the second largest TiO<sub>2</sub> pigment producer worldwide with seven titanium dioxide manufacturing facilities (employs both chloride as well as the sulfate process) located in North America (Texas), Europe, Asia and Africa (Lismore-Scott, 2013). Cristal is the third-largest TiO<sub>2</sub> pigment producer worldwide and vertically integrated into the titanium value chain with its own feedstock deposits. The company has six plants worldwide. The Ashtabula complex in Ohio is the company's largest TiO<sub>2</sub> facility and accounts for 30% of pigment production (through the chloride process) (Cristal USA, Inc., 2013) (Lismore-Scott, 2013).

<sup>76</sup> Bedinger (2014).

Kronos is the fourth largest TiO<sub>2</sub> pigment producer with seven plants in Europe and the North America. The Louisiana Pigment Company located in southwest Louisiana is capable of producing 156,000 MT/y via the chloride process. The Varennes plant in Quebec is the only manufacturing site for TiO<sub>2</sub> pigments in Canada and sole TiO<sub>2</sub>-producer in North America able to produce TiO<sub>2</sub> also by means of the sulfate process (KRONOS Worldwide, Inc, 2017) (Lismore-Scott, 2013).

Tronox is the fifth largest TiO<sub>2</sub> pigment producer with three pigment plants located in the USA, Australia, and Netherlands. The Hamilton's titanium dioxide (TiO<sub>2</sub>) manufacturing operation in Mississippi has an annual production capacity of approximately 225,000 MT/y via the chloride process (Tronox Limited, 2017) (Lismore-Scott, 2013). In February 2017, Tronox Limited announced a definitive agreement to acquire the TiO<sub>2</sub> business of Cristal, a privately held global chemical and mining company, for \$1.67 billion. The deal will make Tronox the largest titanium pigment producer in the world, overtaking DuPont spin-off Chemours, with 11 titanium dioxide plants in eight countries and a total capacity of 1.3 million metric tons per year (Newton, 2017).

Company	Plant location	Yearend capacity
Cristal	Ashtabula, OH	220,000
DuPont Titanium Technologies	De Lisle, MS	340,000
Do.	Edgemoor, DE	190,000
Do.	New Johnsonville, TN	400,000
Louisiana Pigment Co. L.P.	Lake Charles, LA	150,000
Tronox Ltd.	Hamilton, MS	230,000
Total		1,530,000

Figure 61: U.S Producers of Titanium Dioxide Pigment in 2014<sup>77</sup>

### ***Major Titanium Metal Producers***

The United States is a net importer of titanium sponge. U.S. sponge imports originate mainly from Kazakhstan and Japan. Japan had the largest titanium sponge production capacity, accounting for 33 percent of world capacity, followed by Russia at 25 percent, and Kazakhstan at 19 percent. The United States had approximately 8 percent of global titanium sponge production capacity. One Russian company and three U.S. companies are the major producers of high-quality titanium metals. The Russian company, VSMPO-Avisma (Verkhnyaya Salda Metallurgical Production Association) is the world's largest titanium metal producer, with approximately 17 percent of the market share in global titanium shipments. The three major U.S. titanium metal producers are TIMET, Allvac (Allegheny Technologies Inc. [ATI]), and RMI Titanium Company (RTI International Metals, Inc.) (Younossi, Seong, Goldsmith, Lang, & Neumann, 2009).

<sup>77</sup> Bedinger (2014).

*References for Appendix 1*

- AusIMM. (2013). Iluka Resources Operations, Iluka Resources Limited. In V. Hugo, G. Jones, & W. J. Rankin (Ed.), *Australasian mining and metallurgical operating practices: the Sir Maurice Mawby memorial volume* (Third ed., Vol. 2). Carlton, Victoria, Australia: The Australasian Institute of Mining and Metallurgy.
- Bedinger, G. M. (2014). Titanium. In U.S. Geological Survey Minerals Yearbook—2014 (pp. 78.1-78.16). U.S. Geological Survey.
- Cardarelli, F., & Guéguin, M. (2007). Chemistry and mineralogy of titania-rich slags. Part 1 - Hemo-ilmenite, sulphate, and upgraded titania slags. *Mineral Processing Extractive Metallurgy Review*, 1-58.
- Chatterjee, K. K. (2007). Ilmenite and Titanium. In *Uses of Metals and Metallic Minerals* (pp. 50-61). New Delhi: New Age International (P) Ltd.
- Comyns, A. E. (2014). *Encyclopedic Dictionary of Named Processes in Chemical Technology* (Fourth ed.). Boca Raton, Florida, USA: CRC Press.
- Cristal USA, Inc. (2013, March). Ashtabula Complex. Ashtabula, Ohio, USA. Retrieved March 11, 2017, from [http://www.cristal.com/Corporate%20Fact%20Sheet/Ashtabula\\_Complex\\_EN.pdf](http://www.cristal.com/Corporate%20Fact%20Sheet/Ashtabula_Complex_EN.pdf)
- Dujardin, J.-D., & Fourcade, J.-M. (2011, October 11). Creation of a vertically integrated player in the mineral sands sector. Retrieved March 11, 2017, from ERAMET: [http://www.eramet.com/system/files/publications/pdf/pres\\_sfaf\\_tizir\\_2011\\_fr\\_261011.pdf](http://www.eramet.com/system/files/publications/pdf/pres_sfaf_tizir_2011_fr_261011.pdf)
- Ellsworth, D. K., Verhulst, D., Spitler, T. M., & Sabacky, B. J. (2000, December). Titanium nanoparticles move to the marketplace. *Chemical Innovation*, 30(12), 30-35.
- Elsner, H. (2010). Ilmenite and leucoxene. In *Heavy Minerals of Economic Importance* (pp. 23-55). Hannover, Lower Saxony, Germany: Federal Institute of Geosciences and Natural Resources (BGR).
- Gambogi, J. (2003). TITANIUM. Retrieved from The United States Geological Survey: <https://minerals.usgs.gov/minerals/pubs/commodity/titanium/titanmyb03.pdf>
- Geoscience Australia. (2015). Titanium Fact Sheet. Retrieved March 11, 2017, from Australian Mines Atlas: [http://www.australianminesatlas.gov.au/education/fact\\_sheets/titanium.html](http://www.australianminesatlas.gov.au/education/fact_sheets/titanium.html)
- Gilman, S. K., & Taylor, R. K. (2001). The Future for Ilmenite Beneficiation Technologies. *International heavy minerals conference* (pp. 177-186). Fremantle, WA: Australasian Institute of Mining and Metallurgy.

Gous, M. (2006). An overview of the Namakwa Sands Ilmenite Smelting Operations. In R. Jones (Ed.), *Southern African Pyrometallurgy 2006* (pp. 189-201). Johannesburg: South African Institute of Mining and Metallurgy.

Hildal, A., & Seim, S. (2016, November 11). Retrieved March 11, 2017, from SINTEF: [https://www.sintef.no/contentassets/41bc7c5bfefe41b4935c55f2859daece/3-1-ilmenite-pellet-production-and-use-at-tizir\\_arne-hildal.pdf](https://www.sintef.no/contentassets/41bc7c5bfefe41b4935c55f2859daece/3-1-ilmenite-pellet-production-and-use-at-tizir_arne-hildal.pdf)

Iluka Resources. (2014). *The Mineral Sands Industry Factbook*. Retrieved March 11, 2017, from Iluka Resources: [https://www.iluka.com/docs/default-source/industry-company-information/the-mineral-sands-industry-factbook-\(feb-2014\)](https://www.iluka.com/docs/default-source/industry-company-information/the-mineral-sands-industry-factbook-(feb-2014))

Jones, R., Curr, T., & Barcza, N. (1993). *Plasma Developments in Africa. 2nd International Plasma Symposium: World Progress in Plasma Applications*. Palo Alto, California, USA. Retrieved March 11, 2017, from <http://www.pyrometallurgy.co.za/Mintek/Plasma/Plasma.htm>

KRONOS Worldwide, Inc. (2017). *Manufacturing-Facilities*. Retrieved March 11, 2017, from KRONOS Worldwide, Inc: <http://kronostio2.com/en/manufacturing-facilities>

Lakshmanan, V. I., Roy, R., & Halim, M. A. (2016). Innovative Process for the Production of Titanium Dioxide. In V. I. Lakshmanan, R. Roy, & V. Ramachandran, *Innovative Process Development in Metallurgical Industry Concept to Commission* (pp. 359-383). Springer International Publishing Switzerland.

Lismore-Scott, S. (2013, November). Whiter than white: TiO<sub>2</sub> in 2014. *Industrial Minerals*, 29-32.

McManus, P. (2013). Overview of the Australasian Mineral Sands Industry. In W. J. Rankin (Ed.), *Australasian mining and metallurgical operating practices: the Sir Maurice Mawby memorial volume* (3rd ed., Vol. 2, pp. 1687-1691). Carlton, Victoria: Australasian Institute of Mining and Metallurgy.

Nafziger, R. H., & Elger, G. W. (1987). Preparation of Titanium Feedstock from Minnesota Ilmenite by Smelting and Sulfation-Leaching. Bureau of Mines Report of Investigations 9065, United States Department of Interior, United States Bureau of Mines.

Newton, J. (2017, March 1). Cristal deal will make Tronox world's largest titanium dioxide producer. Retrieved from The Royal Society of Chemistry: <https://www.chemistryworld.com/news/cristal-deal-will-make-tronox-worlds-largest-titanium-dioxide-producer/2500474.article>

Pistorius, P. C. (2008). Ilmenite smelting: the basics. *The Journal of The Southern African Institute of Mining and Metallurgy*, 35-43.

The Chemours Company. (2017). Retrieved March 11, 2017, from The Chemours Company: <https://www.chemours.com/our-company/timeline/>

Tronox Limited. (2017). Hamilton, Mississippi, U.S. Retrieved March 11, 2017, from <http://www.tronox.com/our-company/global-operations/hamilton-mississippi-u-s/>

USGS. (2016, March 11). TITANIUM MINERAL CONCENTRATES. Retrieved March 11, 2017, from The United States Geological Survey: <https://minerals.usgs.gov/minerals/pubs/commodity/titanium/mcs-2016-timin.pdf>

Williams, G., & Steenkamp, J. (2006). Heavy Mineral Processing at Richards Bay. In R. Jones (Ed.), *Southern African Pyrometallurgy 2006* (pp. 181-188). Johannesburg: South African Institute of Mining and Metallurgy.

Wright, J., Elger, G., Tress, J., & Bell, H. (1985, November). Chlorination-grade feedstock from domestic ilmenite. *Minerals and Metallurgical Processing*, 198-202.

Younossi, O., Seong, S., Goldsmith, B. W., Lang, T., & Neumann, M. J. (2009). *Titanium: Industrial Base, Price Trends, and Technology Initiatives*. RAND Corporation.

Zhang, W., Zhu, Z., & Cheng, C. Y. (2011). A literature review of titanium metallurgical processes. (J. Petersen, Ed.) *Hydrometallurgy*, 108(3-4), 177-188.

*Appendix 2: Estimated HPGR-Spiral-LIMS Metallurgical Balance<sup>78</sup>*

Actual Pilot Results  
Benner, 2001

Product	Wt %
TiO <sub>2</sub> %	TiO <sub>2</sub> Dist %
Fe %	Fe Dist %
SiO <sub>2</sub> %	SiO <sub>2</sub> Dist %

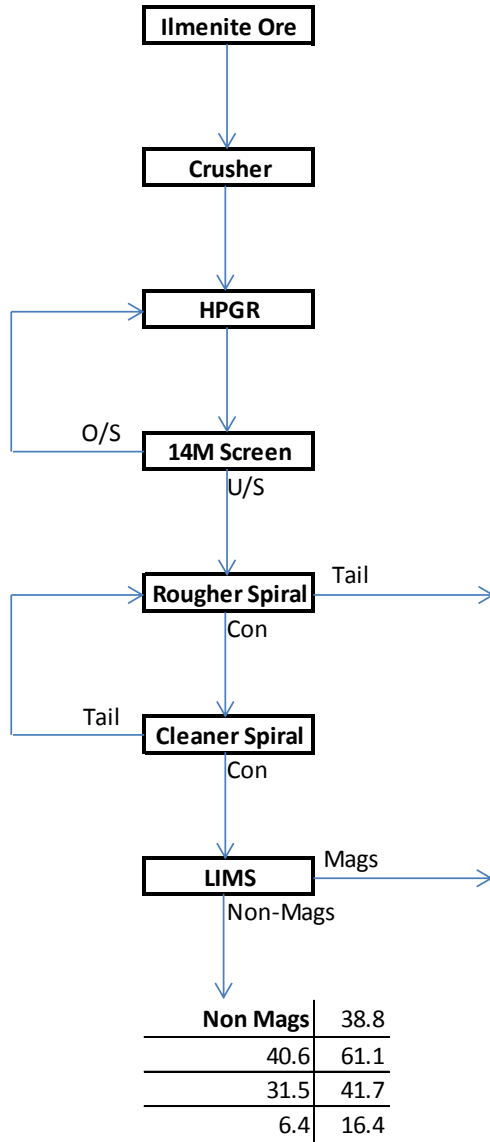

<b>Ilmenite Ore</b>	100.0
25.8	100.0
29.5	100.0
15.8	100.0

<b>Rougher Tail</b>	35.2
10.1	13.9
21.3	25.5
28.7	66.3

<b>Mags</b>	26.0
25.1	25.1
37.1	32.8
10.2	17.4

<b>Non Mags</b>	38.8
40.6	61.1
31.5	41.7
6.4	16.4

<sup>78</sup> Benner (2001).

### *Appendix 3: Process Research Ortech Chemical Assay Details*

PRO is capable of performing the following tests:

#### *Solution analysis by ICP*

Solutions for analysis by ICP are first filtered using Whatman #3 filter paper, to remove any trace amounts of organic that may be entrained in the solution. When necessary, samples are then quantitatively diluted to bring the metal concentrations inside a linear calibration range. Results from the ICP are used in combination with a dilution factor to back calculate original solution concentrations.

#### *Solids analysis by XRF*

Solids for analysis by XRF are first completely dried in an oven. After drying, the samples can be directly analyzed, non-destructively, using XRF.

#### *Solids analysis by Multi Acid Digestion*

A solid sample is completely dissolved in a mixture of hydrochloric acid (HCl), nitric acid (HNO<sub>3</sub>), and hydrofluoric acid (HF). The dissolved solution is then quantitatively diluted and analyzed using the ICP. Based on the results of the ICP the solid composition is back calculated to determine element percentages.

*Appendix 4: XRF and ICP-OES Analyses by AGAT Laboratories on Testing Sample*

# CERTIFICATE OF ANALYSIS

**AGAT WORK ORDER:** 16T079702  
**PROJECT:** 15-28/16-05  
**CLIENT NAME:** PROCESS RESEARCH ORTECH INC.  
**ATTENTION TO:** JONATHAN CHEN  
**DATE RECEIVED:** Mar 24, 2016  
**DATE SAMPLED:** Mar 24, 2016  
**DATE REPORTED:** Mar 31, 2016

**PACKAGE INFORMATION:**

Work Sheet Name	Sample T Package Name
X01	Other (201-070) 4 Acid Digest - Metals Package, ICP-OES finish
X02	Other (201-676) Lithium Borate Fusion - Summation of Oxides, XRF finish

Analyte:	Al2O3	BaO	CaO	Cr2O3	Fe2O3	K2O	MgO	MnO	Na2O	P2O5	SiO2	TiO2	SrO	V2O5	LOI	Total
Unit:	%	%	%	%	%	%	%	%	%	%	%	%	%	%	%	%
RDL:	0.01	0.01	0.01	0.01	0.01	0.01	0.01	0.01	0.01	0.01	0.01	0.01	0.01	0.01	0.01	0.01
Ilmenite Head	1.05	<0.01	0.92	0.10	40.20	0.05	13.80	0.32	0.02	0.02	16.60	25.40	<0.01	0.25	2.17	101.00

Analyte:	Ag	Al	As	Ba	Be	Bi	Ca	Cd	Ce	Co	Cr	Cu	Fe	Ga	In	K
Unit:	ppm	%	ppm	ppm	ppm	ppm	%	ppm	ppm	ppm	ppm	ppm	%	ppm	ppm	%
RDL:	0.5	0.01	1	1	0.5	1	0.01	0.5	1	0.5	0.5	0.5	0.01	5	1	0.01
Ilmenite Head	<0.5	0.52	<1	11.00	3.90	<1	0.61	<0.5	44.00	169.00	589.00	1,770.00	27.90	<5	24.00	0.04

Analyte:	La	Li	Mg	Mn	Mo	Na	Ni	P	Pb	Rb	S	Sb	Sc	Se	Sn	Sr
Unit:	ppm	ppm	%	ppm	ppm	%	ppm	ppm	ppm	ppm	%	ppm	ppm	ppm	ppm	ppm
RDL:	2	1	0.01	1	0.5	0.01	0.5	10	1	10	0.01	1	1	10	5	1
Ilmenite Head	<2	5.00	8.09	2,590.00	<0.5	0.07	633.00	80.00	75.00	12.00	0.10	<1	39.00	<10	<5	13.00

Analyte:	Ta	Te	Th	Ti	Tl	U	V	W	Y	Zn	Zr
Unit:	ppm	ppm	ppm	%	ppm	ppm	ppm	ppm	ppm	ppm	ppm
RDL:	10	10	5	0.01	5	5	0.5	1	1	0.5	5
Ilmenite Head	<10	<10	<5	>10	<5	<5	1,270.00	<1	<1	186.00	104.00

Parameter	Sample Id	Original	Rep #1	RPD	Method Blank	Result Value	Reference Material	Nominal	Recovery	Lower Limit	Upper Limit
<b>(202-052) Fire Assay - Trace Au, ICP-OES finish (ppm)</b>											
Au	7457746	0.965	0.981	1.6%	< 0.001	1.48	ref.1P5L	1.53	97%	90%	110%
<b>(201-070) 4 Acid Digest - Metals Package, ICP-OES finish</b>											
Ag	7457747	< 0.5	< 0.5	0.0%	< 0.5					90%	110%
Al	7457747	0.521	0.547	4.9%	< 0.01	7.34	ref.GTS-2a	6.96	105%	90%	110%
As	7457747	< 1	< 1		< 1	112	ref.GTS-2a	124	90%	90%	110%
Ba	7457747	11	14	24.0%	< 1	171	ref.GTS-2a	186	92%	90%	110%
Be	7457747	3.9	3.6	8.0%	< 0.5					90%	110%
Bi	7457747	< 1	< 1	0.0%	< 1					90%	110%
Ca	7457747	0.605	0.581	4.0%	< 0.01	3.74	ref.GTS-2a	4.01	93%	90%	110%
Cd	7457747	< 0.5	< 0.5	0.0%	< 0.5					90%	110%
Ce	7457747	44	35	22.8%	< 1	25	ref.GTS-2a	24	103%	90%	110%
Co	7457747	169	164	3.0%	< 0.5	21.1	ref.GTS-2a	22.1	96%	90%	110%
Cr	7457747	589	633	7.2%	< 0.5					90%	110%
Cu	7457747	1770	1780	0.6%	< 0.5	89.7	ref.GTS-2a	88.6	101%	90%	110%
Fe	7457747	27.9	27.2	2.5%	< 0.01	7.62	ref.GTS-2a	7.56	101%	90%	110%
Ga	7457747	< 5	< 5	0.0%	< 5					90%	110%
In	7457747	24	21	13.3%	< 1					90%	110%
K	7457747	0.04	0.04	0.0%	< 0.01	2.177	ref.GTS-2a	2.021	108%	90%	110%
La	7457747	< 2	< 2	0.0%	< 2					90%	110%
Li	7457747	5	5	0.0%	< 1					90%	110%
Mg	7457747	8.09	8.02	0.9%	< 0.01	2.46	ref.GTS-2a	2.412	102%	90%	110%
Mn	7457747	2590	2590	0.0%	< 1	1538	ref.GTS-2a	1510	102%	90%	110%
Mo	7457747	< 0.5	< 0.5	0.0%	< 0.5					90%	110%
Na	7457747	0.065	0.064	1.6%	< 0.01	0.602	ref.GTS-2a	0.617	98%	90%	110%
Ni	7457747	633	617	2.6%	< 0.5	78.9	ref.GTS-2a	77.1	102%	90%	110%
P	7457747	80	90	11.8%	< 10	951	ref.GTS-2a	892	107%	90%	110%
Pb	7457747	75	79	5.2%	< 1					90%	110%
Rb	7457747	12	13	8.0%	< 10					90%	110%
S	7457747	0.10	0.11	9.5%	< 0.01	0.355	ref.GTS-2a	0.348	102%	90%	110%
Sb	7457747	< 1	< 1	0.0%	< 1					90%	110%
Sc	7457747	39	41	5.0%	< 1					90%	110%
Se	7457747	< 10	12		< 10					90%	110%
Sn	7457747	< 5	< 5	0.0%	< 5					90%	110%
Sr	7457747	13	11	16.7%	< 1	87.7	ref.GTS-2a	92.8	95%	90%	110%
Ta	7457747	< 10	21		< 10					90%	110%
Te	7457747	< 10	< 10	0.0%	< 10					90%	110%
Th	7457747	< 5	< 5	0.0%	< 5					90%	110%
Ti	7457747	12.5	13.6	8.4%	< 0.01					90%	110%
Tl	7457747	< 5	< 5	0.0%	< 5					90%	110%
U	7457747	< 5	< 5	0.0%	< 5					90%	110%
V	7457747	1270	1350	6.1%	< 0.5					90%	110%
W	7457747	< 1	< 1	0.0%	< 1					90%	110%
Y	7457747	< 1	< 1	0.0%	< 1					90%	110%
Zn	7457747	186	187	0.5%	< 0.5	201	ref.GTS-2a	208	97%	90%	110%
Zr	7457747	104	112	7.4%	< 5					90%	110%
<b>(201-676) Lithium Borate Fusion - Summation of Oxides, XRF finish</b>											
Al2O3	7457747	1.05	1.05	0.3%	< 0.01	20.8	sy-4	20.69	100%	90%	110%
BaO	7457747	<0.01	<0.01	0.0%	< 0.01	0.040	sy-4	0.04	100%	90%	110%
CaO	7457747	0.92	0.93	0.2%	< 0.01	8.09	sy-4	8.05	100%	90%	110%
Cr2O3	7457747	0.10	0.10	5.0%	< 0.01			0.01		90%	110%
Fe2O3	7457747	40.2	40.1	0.0%	< 0.01	6.34	sy-4	6.21	102%	90%	110%
K2O	7457747	0.05	0.05	4.2%	< 0.01	1.66	sy-4	1.66	100%	90%	110%
MgO	7457747	13.8	13.8	0.0%	< 0.01	0.520	sy-4	0.54	96%	90%	110%
MnO	7457747	0.32	0.33	2.0%	< 0.01	0.113	sy-4	0.108	104%	90%	110%
Na2O	7457747	0.02	0.02	28.6%	< 0.01	7.12	sy-4	7.1	100%	90%	110%
P2O5	7457747	0.02	0.02	0.0%	< 0.01	0.119	sy-4	0.131	91%	90%	110%
SiO2	7457747	16.6	16.5	0.1%	< 0.01	50.1	sy-4	49.9	100%	90%	110%
TiO2	7457747	25.4	25.4	0.2%	< 0.01	0.291	sy-4	0.287	101%	90%	110%
SiO	7457747	<0.01	<0.01	0.0%	< 0.01	0.137	sy-4	0.1408	97%	90%	110%
V2O5	7457747	0.25	0.26	1.6%	< 0.01					90%	110%

Contact:

**Ontario Region**  
**Main Office**  
 5835 Coopers Avenue  
 Mississauga, Ontario  
 L4Z 1Y2  
 Tel: 905.712.5100  
 Fax: 905.712.5122

Appendix 5: QEMSCAN Analysis by Integrated Process Mineral Solutions (IPMINS)

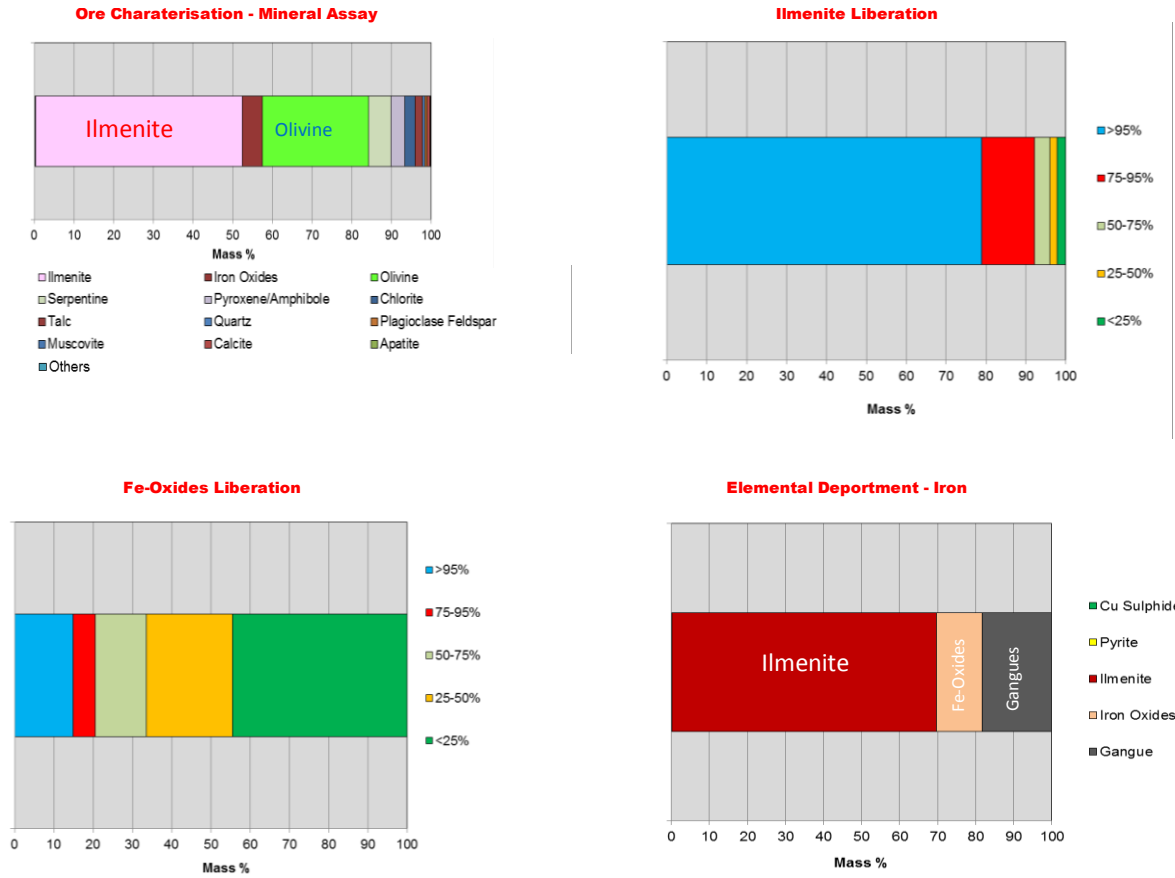

Modal Analysis Data	
Mineral Abundance	Ilmenite
Ilmenite	51.9
Iron Oxides <sup>*1</sup>	4.96
Olivine	26.7
Serpentine	5.64
Pyroxene/Amphibole	3.44
Chlorite	2.61
Talc	1.76
Quartz	0.63
Feldspar	0.52
Muscovite	0.12
Calcite	0.62
Cu-sulphides <sup>*2</sup>	0.14
Pyrite	0.03
Rutile/anatase	0.08
Others <sup>*3</sup>	0.88
Total	100.00

\*<sup>1</sup>including hematite, goethite, magnetite and limonite.

\*<sup>2</sup>including chalcopyrite, bornite, covellite and chalcocite

\*<sup>3</sup>including barite, apatite, Cu-sulphate/oxides/carbonates & sphalerite

Assay Reconciliation - QEMSCAN vs Chemical	
Elements (%)	Ilmenite
Al - QEMSCAN	0.42
- Chemical	0.56
Ca - QEMSCAN	0.67
- Chemical	0.66
Fe - QEMSCAN	28.8
- Chemical	28.1
Mg- QEMSCAN	8.51
- Chemical	8.32
Ti - QEMSCAN	15.6
- Chemical	15.2
Si - QEMSCAN	8.20
- Chemical	7.75

Estimated grain-size (µm)	
in Ilmenite sample	
Ilmenite	22
Iron Oxides <sup>*1</sup>	7
Olivine	21
Serpentine	9
Pyroxene/Amphibole	21
Chlorite	13
Talc	7
Quartz	14
Feldspar	20
Muscovite	10
Calcite	17
Cu-sulphides <sup>*2</sup>	9
Pyrite	6
Rutile/anatase	23
Others <sup>*3</sup>	6

**Ilmenite Liberation (mass % ilmenite in sample)**

Liberation	Ilmenite
>95% Liberated	78.9
75-95% Liberated	13.2
50-75% Liberated	3.8
25-50% Liberated	1.9
0-25% Liberated	2.1
<b>Total</b>	<b>100.0</b>

**Fe-Oxides\* Liberation (mass % Fe-Oxides in sample)**

Liberation	Fe-Oxides
>95% Liberated	14.8
75-95% Liberated	5.7
50-75% Liberated	13.1
25-50% Liberated	21.9
0-25% Liberated	44.5
<b>Total</b>	<b>100.0</b>

\*including magnetite, goethite, hematite and limonite

**Sulphides\* Liberation (mass % sulphides in sample)**

Liberation	sulphides
>95% Liberated	53.1
75-95% Liberated	12.7
50-75% Liberated	7.3
25-50% Liberated	4.6
0-25% Liberated	22.3
<b>Total</b>	<b>100.0</b>

\*including pyrite, sphalerite, chalcopyrite, covellite and bornite

**Fe- deoportment in Ilmenite**

<b>Mineral</b>	<b>Ilmenite</b>
Ilmenite	69.5
Iron Oxides	12.1
Sulphides	0.1
Silicates	18.3
Total	<i>100.0</i>

Data presented as mass% in sample

**Ti- deoportment in Ilmenite**

<b>Mineral</b>	<b>Ilmenite</b>
Ilmenite	99.6
Rutile/anatase	0.3
Iron Oxides	0.1
Total	<i>100.0</i>

Data presented as mass% in sample

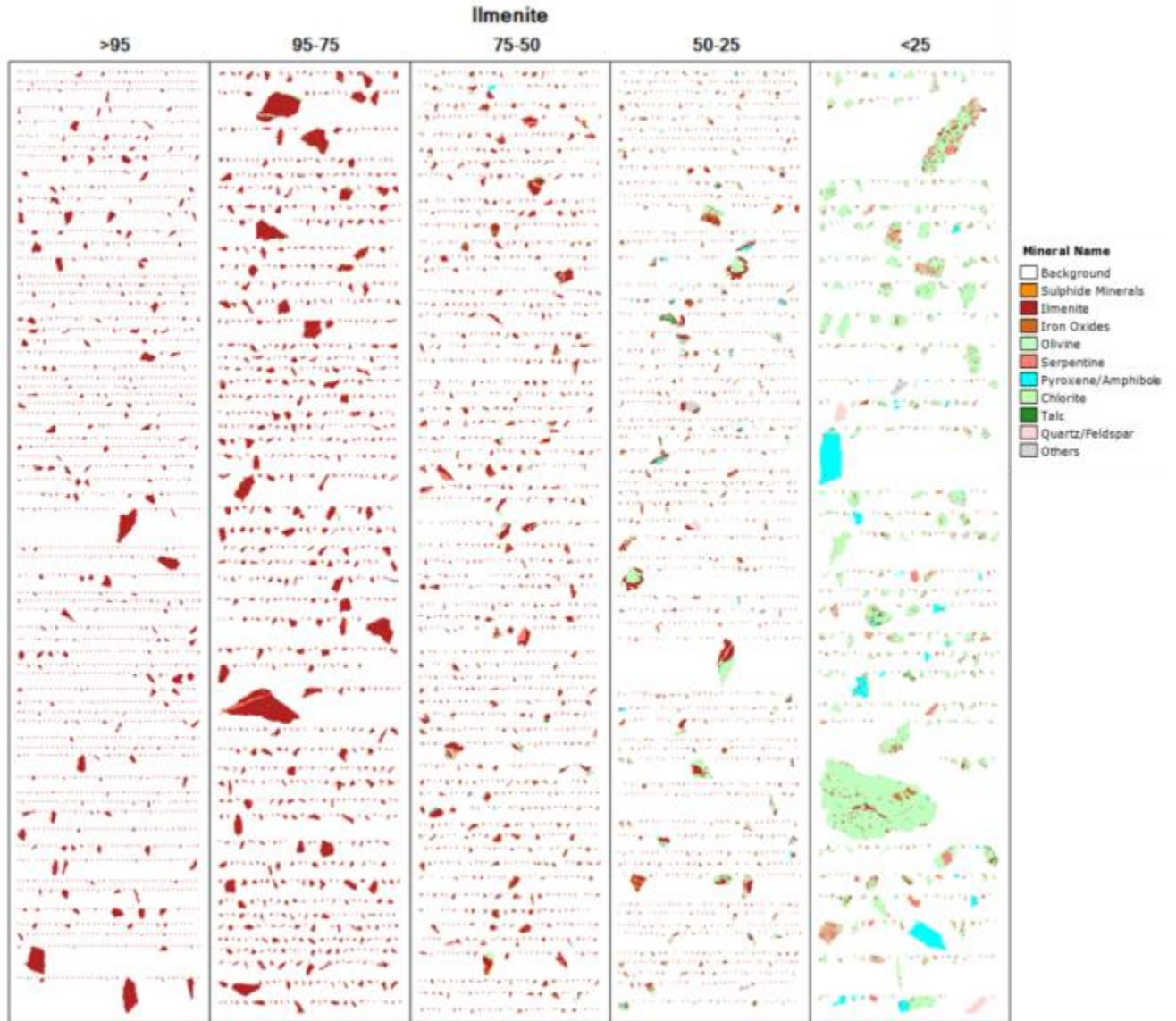

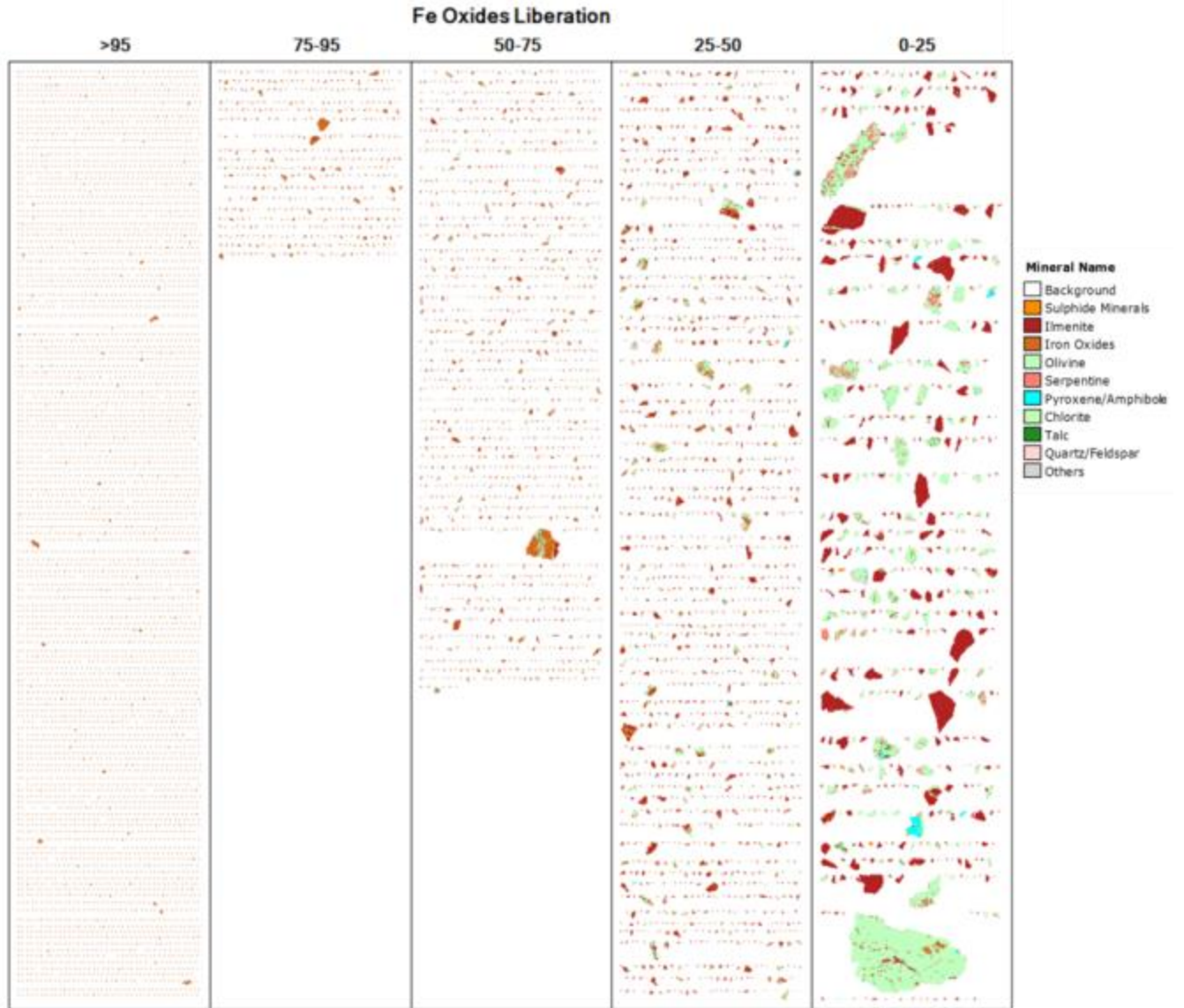

Sample	Grind Time	Size range	Weights	
			(g)	(%)
Ilmenite	20+20	+150 µm	53.7	20.8
		-150 to +125 µm	10.3	4.0
		-125 to +106 µm	11.3	4.4
		-106 to +75 µm	35.2	13.7
		-75 to +53 µm	27.0	10.5
		-53 to +38 µm	25.6	9.9
		-38 to +20 µm	54.4	21.1
		-20 µm	40.2	15.6
		<b>Total</b>		<b>257.7</b>

Mesh Size in	Percentage of
150.0	79.2
125.0	75.2
106.0	70.8
75.0	57.1
53.0	46.6
38.0	36.7
20.0	15.6

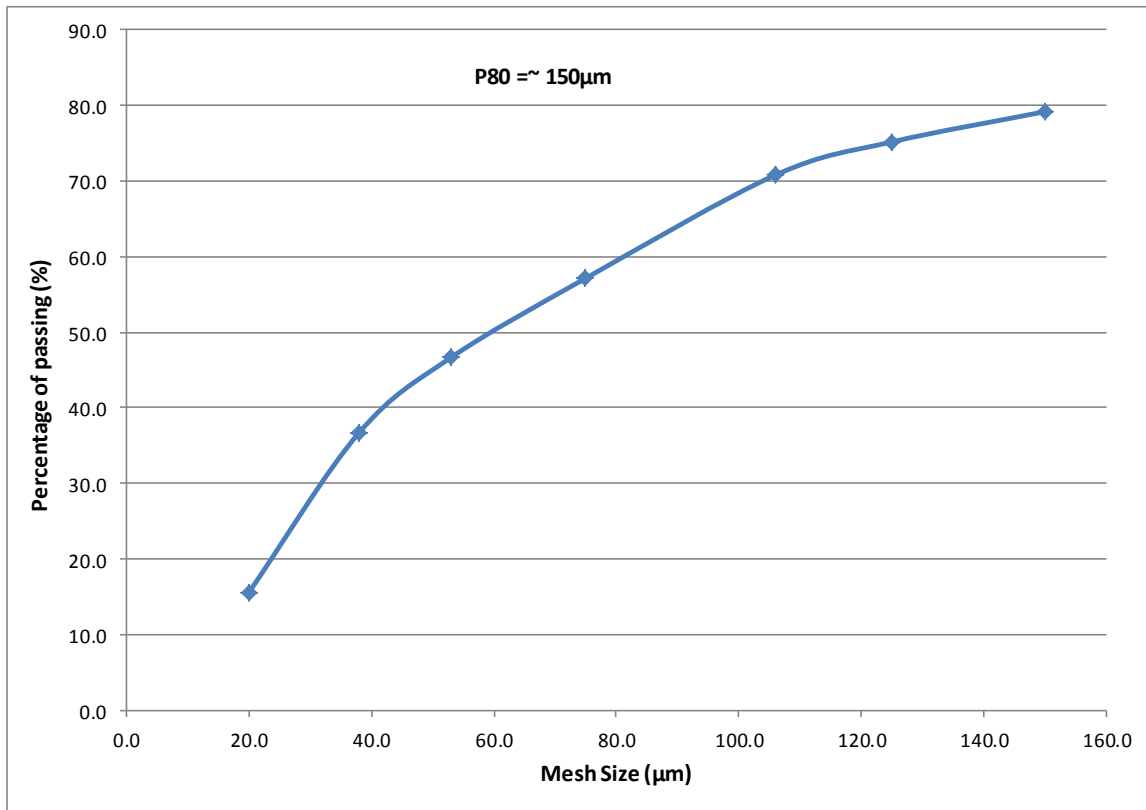

Contact:

Integrated Process Mineralogy Solutions  
 5646 Patron Cove,  
 Mississauga, ON.  
 L5M 7G4.  
 Tel: 416 806 4491

*Appendix 6: Optical Microscopy Analysis by Integrated Process Mineral Solutions (IPMINS)*

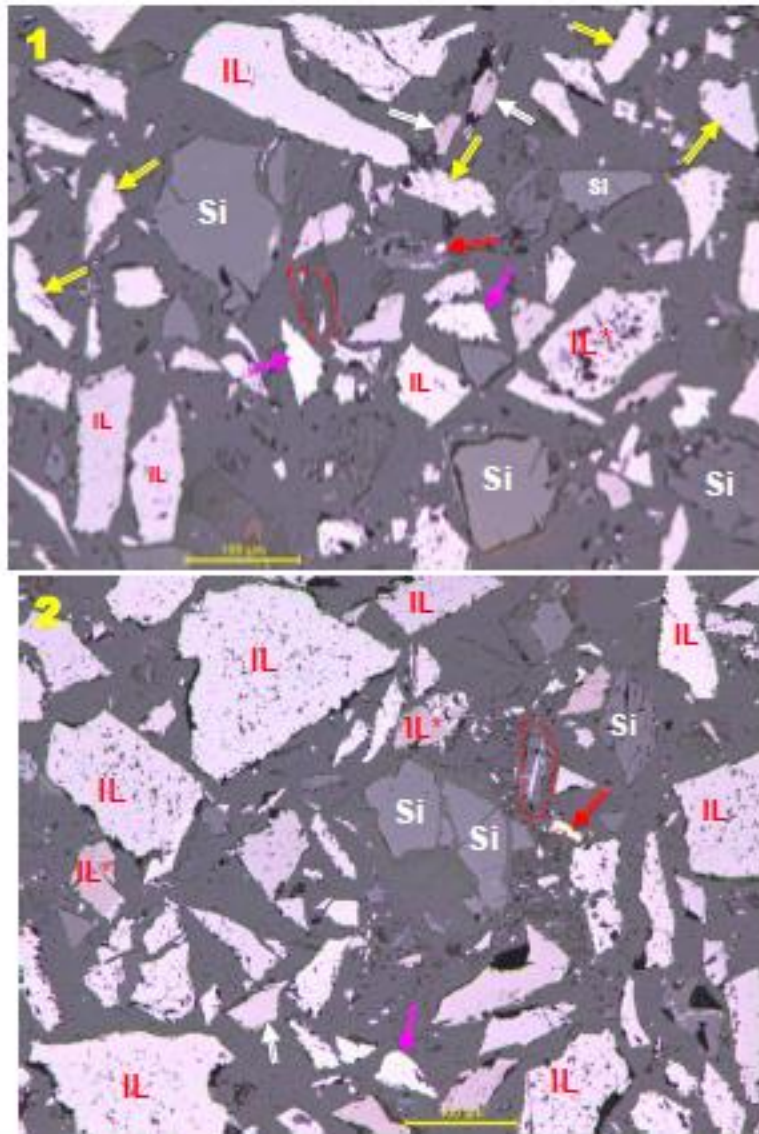

Photomicrographs of ilmenite sample showing general association of different phases  
 Plate 1: Liberated ilmenite (yellow arrow/IL), silicates (Si), hematite (pink arrow), magnetite (white arrow), pyrite (red arrow), composite ilmenite-magnetite-hematite (IL\*) and locked ilmenite-hematite-magnetite in silicates (red lines/circle)  
 Plate 2: Liberated ilmenite (IL), silicates (Si), hematite (pink arrow), chalcopyrite (red arrow), composite ilmenite-magnetite-hematite (IL\*) and locked ilmenite-hematite-magnetite in silicates (red lines/circle)

*Providing the insight for high confidence Metallurgy Diagnostics*

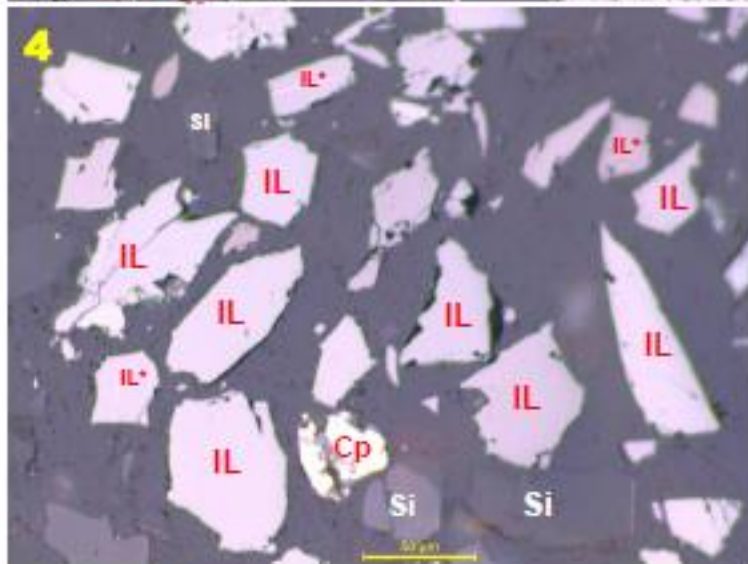
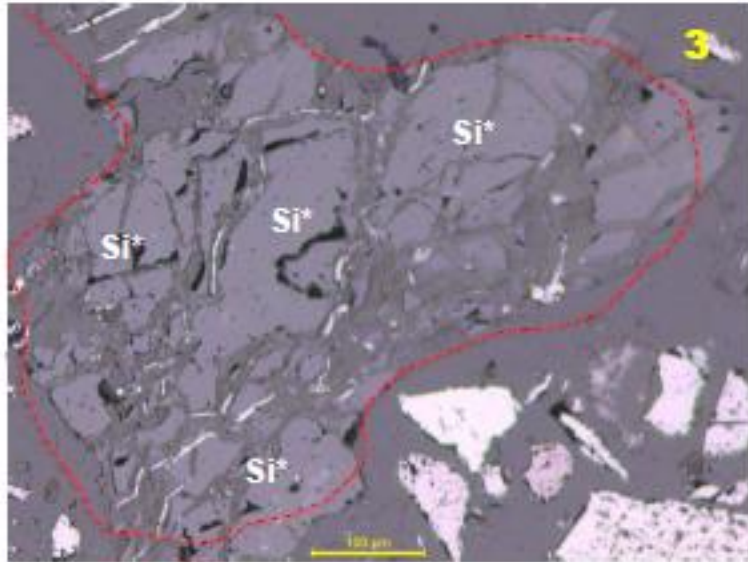

Photomicrographs of ilmenite sample showing general association of different phases  
Plate 3: Fine grained locked ilmenite within silicates (red arrow)  
Plate 4: Liberated ilmenite (IL), silicates (Si), chalcopyrite (Cp), composite ilmenite-magnetite-hematite (IL\*)

*Providing the insight for high confidence Metallurgy Diagnostics*

*Appendix 7: Pilot-Scale Beneficiation Process Metallurgical Balance*

Product	Weight Dist (%)	TiO2 (%)	Total Fe (%)	SiO2 (%)	MgO (%)	V2O5 (%)
Ilmenite Testing Sample	100.0	25.67	27.85	15.10	13.47	0.27
High Silica Tailings	45.0	10.71	20.21	27.09	21.05	0.11
Magnetite/Titano-magnetite Concentrate	9.4	24.40	45.07	4.64	6.14	0.67
Ilmenite Concentrate	45.5	38.93	31.09	6.43	7.57	0.32
<b>Calculated Head</b>	<b>100.0</b>	<b>24.85</b>	<b>27.51</b>	<b>15.57</b>	<b>13.51</b>	<b>0.26</b>

TiO2 Dist (%)	Total Fe Dist (%)	SiO2 Dist (%)	MgO Dist (%)	V2O5 Dist (%)
100.0	100.0	100.0	100.0	100.0
19.4	32.7	79.4	70.0	19.1
9.3	15.5	2.7	4.3	24.4
71.3	51.8	17.9	25.7	56.5
<b>100.0</b>	<b>100.0</b>	<b>100.0</b>	<b>100.0</b>	<b>100.0</b>

*Appendix 8: Summary of Beneficiation Composite Pilot Products Sizing Data*

Sieve Size	Sieve Size	Ilmenite Testing Sample	High Silica Tailings	Magnetite/Titanomagnetite Concentrate	Ilmenite Concentrate
Tyler Mesh	Micron	% Passing	% Passing	% Passing	% Passing
1	25,400	100.0	100.0	100.0	100.0
3/4	19,050	92.6	100.0	100.0	100.0
5/8	15,875	82.3	100.0	100.0	100.0
1/2	12,700	71.4	100.0	100.0	100.0
3/8	9,525	61.3	100.0	100.0	100.0
3	6,730	48.6	100.0	100.0	100.0
4	4,800	41.7	100.0	100.0	100.0
6	3,400	33.7	100.0	100.0	100.0
8	2,400	26.8	100.0	100.0	100.0
10	2,000	20.3	100.0	100.0	100.0
14	1,420	14.4	100.0	100.0	100.0
20	850	9.1	95.4	100.0	100.0
28	600	7.0	85.7	100.0	100.0
35	425	5.6	74.4	99.4	100.0
48	300	4.6	65.0	98.2	99.8
65	212	3.7	59.3	96.2	99.4
100	150	3.2	55.2	93.3	97.7
150	106	2.4	50.7	89.0	94.5
200	75	2.0	44.4	82.6	88.7
270	53	1.6	36.4	74.2	79.8
325	45	1.6	32.4	69.6	74.0
400	37	1.2	28.4	64.5	68.6
500	25	1.0	23.1	56.5	59.6
-500	-25	0.0	0.0	0.0	0.0
<b>P80 (microns)</b>		<b>15,205</b>	<b>512</b>	<b>68</b>	<b>54</b>

*Appendix 9: XRF and ICP-OES Analyses by AGAT Laboratories on Ilmenite Concentrate*

# CERTIFICATE OF ANALYSIS

**AGAT WORK ORDER:** 16T133272  
**PROJECT:** 16-05  
**CLIENT NAME:** PROCESS RESEARCH ORTECH INC.  
**ATTENTION TO:** JONATHAN CHEN  
**DATE RECEIVED:** Sep 01, 2016  
**DATE SAMPLED:** Sep 01, 2016  
**DATE REPORTED:** Sep 09, 2016

**PACKAGE INFORMATION:**

Work Sheet Name	Sample T Package Name
X01	Other (201-079) Sodium Peroxide Fusion - ICP-OES finish
X02	Other (201-676) Lithium Borate Fusion - Summation of Oxides, XRF finish

**(201-079) Sodium Peroxide Fusion - ICP-OES finish**

Sample Id	Sample Description	Analyte:	Al	As	B	Ca	Co	Cr	Cu	Fe
		Unit:	%	%	%	%	%	%	%	%
		RDL:	0.01	0.005	0.01	0.05	0.001	0.005	0.001	0.01
7817493	16-0616 Bulk Ilmenite Conc - Head		0.28	<0.005	<0.01	0.2	0.017	0.044	0.1	30

**Comments:** RDL - Reported Detection Limit

Analyte:	K	Li	Mg	Mn	Mo	Ni	Pb	S
Unit:	%	%	%	%	%	%	%	%
RDL:	0.05	0.01	0.005	0.005	0.005	0.001	0.005	0.01
	<0.05	<0.01	4.4	0.348	0.008	0.042	<0.005	0.04

Analyte:	Si	Sn	Ti	V	W	Zn
Unit:	%	%	%	%	%	%
RDL:	0.005	0.005	0.005	0.005	0.01	0.005
	3.26	<0.005	23.4	0.141	<0.01	0.025

**(201-676) Lithium Borate Fusion - Summation of Oxides, XRF finish**

Sample Id	Sample Description	Analyte:	Al2O3	BaO	CaO	Cr2O3	Fe2O3	K2O	MgO	MnO
		Unit:	%	%	%	%	%	%	%	%
		RDL:	0.01	0.01	0.01	0.01	0.01	0.01	0.01	0.01
7817493	16-0616 Bulk Ilmenite Conc - Head		0.57	<0.01	0.59	0.06	45	0.02	8	0.43

**Comments:** RDL - Reported Detection Limit

Analyte:	Na2O	P2O5	SiO2	TiO2	SrO	V2O5	LOI	Total
Unit:	%	%	%	%	%	%	%	%
RDL:	0.01	0.01	0.01	0.01	0.01	0.01	0.01	0.01
	0.02	0.01	7.49	40.1	<0.01	0.33	<0.01	102

### ***Appendix 10: Materials of Construction for Process Research Ortech (PRO) Small Pilot-Scale Plant***

In general, the materials used to contain, transfer, and mix fluids through the system must be compatible with both the organic phase (usually composed of an extractant, an alcohol based modifier, and CF-231), and the aqueous phase (usually an acid chloride solution). Other than specialty alloys (Hastelloy B, C) or exotic metals (Zirconium, Niobium, Tantalum), plastics, ceramics, and glass are the only materials that are suitable for long term acid chloride service. In general, plastics, and glass were the primary materials exposed to the process solutions during pilot plant operations. The specific plastics used include polyethylene, polypropylene, and PVC. Highly chemically resistant flexible tubing materials such as Tygon® and PharMed®BPT were also part of the system. When considering the surrounding environment, it is important to note that HCl vapor from the acid chloride solutions will corrode most exposed metal surfaces.

#### **Solvent Extraction Rack and Containment Design**

Solvent extraction racks were custom-fabricated from square steel tube, and epoxy-coated to provide corrosion resistance. Each rack consists of two rails that run the length of the unit and provide support for the mixer-settlers themselves. Centered above the rails is a piece of steel bar on which mixer-support rods are mounted. Bar clamps secure these support rods, and mixer position can easily be changed. Each rack is also fitted with plastic pump trays, containment trays, and shelving. These trays provide containment in the event of organic or aqueous spills, and support the equipment used in the system, including pumps and heating kettles. Every solvent extraction rack also has a custom Polypropylene fume hood positioned above, so that organic vapors are removed from the room and air quality is maintained. A system of floor containment trays with a walking grid was installed around the solvent extraction racks to reduce the risk of injury to operators in the event of a spill, and also to provide solution containment. Electricity is supplied to all equipment through a series of mounted power bars on each rack.

#### **Mixer-Settler Design**

Custom, polypropylene solvent extraction cells were fabricated for PRO for the pilot program. Polycarbonate provides good chemical resistance to the organic solvents and acids being used in the process. Each solvent extraction cell includes a mixer box and settler stage (see Table 32). During operation, aqueous and organic flow into a given mixer box through a “T” connection in the bottom. In the mixer box, organic and aqueous are mixed to form an emulsion, which overflows over a first baffle, travels downwards, and exits into the settler under a second baffle. The emulsion separates back into the distinct organic and aqueous phases in the settler, with the less dense organic phase rising to the top, and the denser aqueous phase moving to the bottom. The organic is collected from the top of the settler through a trough that is connected through the bottom of the tank with a fixed standpipe. The aqueous phase flows underneath a dam at the far end of the settler, into a chamber containing an adjustable standpipe. By adjusting the height of the standpipe, the interface-level in the settler can be set.

**Table 32: Mixer Settler Design**

<b>Square Mixer Box (in)</b>	<b>Mixer Box Volume (L)</b>	<b>Settler Length (in)</b>	<b>Settler Width (in)</b>	<b>Settler Surface Area (in<sup>2</sup>)</b>	<b>Settler Volume (L)</b>
5	2	8	5	40	3.27

**Pumps and Tubing**

Aqueous and organic feed flows and recycle flows were pumped using Masterflex® peristaltic pump drives and heads. The pump heads were fitted with peristaltic tubing in a variety of materials and sizes, depending upon the flowrate and solution being pumped. In general, Tygon Fuel & Lubricant® tubing was used for organic phases, and Pharmed BPT® tubing was used for aqueous phases. Masterflex® pumps and tubing were also used to drive the hot water circulation system used to maintain temperature in the mixer-settlers. Polyethylene and Teflon tubing was used to carry both aqueous and organic process solutions. In all of the peristaltic pump heads the proper tubing (Tygon or PharMed) was used to pump the solutions.

**Mixers and Impellers**

To provide mixing in the solvent extraction cells, IKA RW-20® adjustable rpm mixers were paired with pump-mix impellers. The impeller blade used had a diameter of 2", and was generally positioned near the bottom of the mixer box chamber to generate the required amount of vacuum to draw the aqueous and organic phases into the mixer box. The diameter of the mixer-box chamber used is 5", so the D/T ratio is 0.4.

*Appendix 11: Small Pilot-Scale Sample Assays*

Iron Circuit Small Pilot-Scale Plant Assay Results

Stream	Set	Fe	Ti	V	Cr	Mg	Mn
<b>FPLS</b>	2	33800	26300	218	57.5	63000	546
<b>FPLS</b>	6	36000	16150				
<b>FPLS</b>	15	28800	21500	161.1	94.2	59610	
<b>FPLS</b>	16	31790	23120	170.7	106.4	73850	
<b>FPLS</b>	17	30070	22520	160.8	100.5	60600	
<b>FPLS</b>	18	29175	21792.5	164	95.5	58950	
<b>FE1R</b>	2	78.8	27200	219	59.5	65100	554
<b>FE1R</b>	4	22.3	27200	212	57.6	68200	519
<b>FE1R</b>	6	<5	17000				
<b>FE1R</b>	11	76	19800				
<b>FE1R</b>	15	12.5	22920	166.7	98.4	64010	
<b>FE1R</b>	16	8.8	24010	175.8	110.4	77480	
<b>FE1R</b>	17	554	23760	172.3	107.6	63000	
<b>FE1R</b>	18	<5	22495	181.8	110	61875	
<b>FE1O</b>	18	<5	146	<5	<5	93	
<b>FE2R</b>	18	<5	23785.0	181	108	63350	
<b>FE2O</b>	18	5	219	<5	<5	51	
<b>FE3R</b>	18	<5	25200	182	108	67200	
<b>FE3O</b>	18	8	329	<5	<5	277	
<b>FE4R</b>	18	9.70	25375	179	106	67200	
<b>FE4O</b>	18	1025	193	<5	<5	36	
<b>FE5R</b>	18	2480.25	23673	175	104	63750	
<b>FE5O</b>	18	11365	49	<5	<5	69	
<b>FB</b>	4	120000	200	<0.5	52.9	2200	32
<b>FB</b>	18	107200	38.5	<5	<5	41.1	
<b>FB1R</b>	4	104000	5590	39.6	52	14000	123
<b>FB1R</b>	15	91930	2472	14.2			
<b>FB1R</b>	16	95440	1649	8.8	<5	2451	
<b>FB1R</b>	17	95090	1357	5.2	<5	1479	
<b>FB1R</b>	18	101550	1275.25	5.2	<5	1042.5	
<b>FB1O</b>	18	11440	6	<5	<5	18	
<b>FS1R</b>	2	115000	377	9.8	<0.5	838	6
<b>FS1R</b>	4	115000	187	<0.5	<0.5	382	3
<b>FS1R</b>	6	109000	50				
<b>FS1R</b>	15	87530	54.7	<5			

<b>FS1R</b>	16	101100	27.5	<5	<5	34.2	
<b>FS1R</b>	17	96150	181.8	<5	<5	430.2	
<b>FS1R</b>	18	98625	41.8	<5	<5	35.1	
<b>FS1O</b>	18	9303	32	<5	<5	78	
<b>FS2R</b>	18	76225	16	<5	<5	54.9	
<b>FS2O</b>	18	4110	7	<5	<5	28	
<b>FS3R</b>	18	33875	<5	<5	<5	15	
<b>FS3O</b>	18	86	<5	<5	<5	<5	
<b>FS4R</b>	18	7233	<5	<5	<5	15	
<b>FS4O</b>	18	<5	<5	<5	<5	14	
<b>FS5R</b>	18	205	<5	<5	<5	<15.4	
<b>FS5O</b>	18	<5	<5	<5	<5	<5	
<b>FS6R</b>	18	23	<5	<5	<5	<17.3	
<b>FS6O</b>	18	<5	<5	<5	<5	<5	
<b>FS7R</b>	18	<5	<5	<5	<5	<8.3	
<b>FS7O</b>	18	<5	<5	<5	<5	<5	

## Titanium Circuit Small Pilot-Scale Plant Assay Results

Stream	Set	Fe	Ti	V	Cr	Mg	Mn
<b>TPLS</b>	1	189.7	23830	168.4	85.6	60600	
<b>TPLS</b>	2	6.2	24787.5	163.4	74.8	62325	
<b>TPLS</b>	3	<5	22645	157.2	67.6	57075	
<b>TPLS</b>	4	14.1	27225	202.3	83.5	72625	
<b>TPLS</b>	5	35	26575	200.4	73.6	66450	350
<b>TPLS</b>	6	54.4	27300	200.8	76.3	67475	339.3
<b>TPLS</b>	7	122.8	27250	200.6	80.3	67175	344.1
<b>TPLS</b>	8	61	24287.5	200.7	91.4	64575	356.8
<b>TE1R</b>	1	24.2	118.4	99.2	73.9	62520	
<b>TE1R</b>	2	<5	99.4	70.1	86.5	64125	
<b>TE1R</b>	3	<5	201.1	88.4	78.7	48800	
<b>TE1R</b>	4	<5	154.8	49.3	79.9	66875	
<b>TE1R</b>	5	6.4	63.1	75.9	74.3	66325	203
<b>TE1R</b>	6	7.4	128.8	145.9	77.2	67250	266.1
<b>TE1R</b>	7	<5	53.1	113.4	74.9	62725	245.7
<b>TE1R</b>	8	<5	45.5	127.9	75.5	64675	278.9
<b>TB</b>	1	<5	37600	102.6	44.9	32870	
<b>TB</b>	2	<5	35575	116.6	47.8	31650	
<b>TB</b>	3	6.2	32975	99.1	38.3	30200	
<b>TB</b>	4	<5	38525	120.7	43.5	36000	
<b>TB</b>	5	13.4	38300	121.1	39.1	34075	212.1
<b>TB</b>	6	40.9	39850	121.8	41.6	36825	212.6
<b>TB</b>	7	66.3	38700	119.5	42.8	34550	208.2
<b>TB</b>	8	64.3	36375	124.6	48.8	33950	227.1
<b>TB1R</b>	1	6.7	25030	270.3	61.3	51300	
<b>TB1R</b>	2	<5	13395	348.6	80.1	54150	
<b>TB1R</b>	3	28.8	16155	288	64.6	54050	
<b>TB1R</b>	4	<5	12605	374	72.9	60050	
<b>TB1R</b>	5	15.5	15880	397.4	67.3	51475	541.8
<b>TB1R</b>	6	<5	19825	374.4	71.8	52675	526.4
<b>TB1R</b>	7	20.1	29325	323.4	62.8	46725	502.9
<b>TB1R</b>	8	<5	27375	361.6	60.1	45000	556.1
<b>TS1R</b>	1	<5	47040	132.9	31.9	22040	
<b>TS1R</b>	2	5.9	46150	87.1	19.8	11222.5	
<b>TS1R</b>	3	<5	41975	107.7	24.8	12467.5	
<b>TS1R</b>	4	<5	48875	95.6	18.9	6172.5	
<b>TS1R</b>	5	10.8	50850	91.7	15.8	9102.5	146.3

<b>TS1R</b>	6	<5	51050	56.7	9.6	3252.5	75.9
<b>TS1R</b>	7	<5	50700	60.9	9.9	4805	98.5
<b>TS1R</b>	8	<5	47500	68.7	9.2	4500	116.9

## ***Appendix 12: Materials of Construction for Process Research Ortech (PRO) Large Pilot-Scale Plant***

The equipment used for the large pilot-scale plant was similar in design to the small pilot-scale plant due to its chemical resistance and ability to be easily modified. Solvent extraction racks were custom-fabricated from square steel tube, and epoxy-coated to provide corrosion resistance. Each rack consists of two rails that run the length of the unit and provide support for the mixer-settlers themselves. Centered above the rails is a piece of steel bar on which mixer-support rods are mounted. Bar clamps secure these support rods, and mixer position can easily be changed. Custom, polypropylene solvent extraction cells were fabricated for PRO for the pilot program. Polypropylene provides good chemical resistance to the organic solvents and acids being used in the process. Each solvent extraction cell includes a mixer box and settler stage (see Table 33).

**Table 33: Large Pilot-Scale Plant Mixer Settler Design**

<b>Circuit</b>	<b>Square Mixer Box (in)</b>	<b>Mixer Box Volume (L)</b>	<b>Settler Length (in)</b>	<b>Settler Width (in)</b>	<b>Settler Surface Area (in<sup>2</sup>)</b>	<b>Settler Volume (L)</b>
Iron (Extraction and Scrubbing)	7	5.6	21	7	147	16.9
Iron (Stripping)	5	2	16	5	80	6.6
Titanium	8	8.4	21	8	168	22

### **Pumps and Tubing**

Aqueous and organic feed flows and recycle flows were pumped using Masterflex® peristaltic pump drives and heads. The pump heads were fitted with peristaltic tubing in a variety of materials and sizes, depending upon the flowrate and solution being pumped. In general, Tygon Fuel & Lubricant® tubing was used for organic phases, and Pharmed BPT® tubing was used for aqueous phases. Masterflex® pumps and tubing were also used to drive the hot water circulation system used to maintain temperature in the mixer-settlers. Polyethylene and Teflon tubing was used to carry both aqueous and organic process solutions. In all of the peristaltic pump heads the proper tubing (Tygon or PharMed) was used to pump the solutions.

### **Mixers and Impellers**

To provide mixing in the solvent extraction cells, IKA RW-20® adjustable rpm mixers were paired with pump-mix impellers. The impeller blade used had either a diameter of 2” or 3” depending on the size of the mixer box, and was generally positioned near the bottom of the mixer box chamber to generate the required amount of vacuum to draw the aqueous and organic phases into the mixer box. For the 7” and 8” mixer boxes a 3” impeller was used resulting in D/T ratios of 0.43 and 0.38 while the 5” mixer boxes used 2” impellers for a D/T ratio of 0.4.

*Appendix 13: Large Pilot-Scale Sample Assays*

## Iron Circuit Large Pilot-Scale Assay Results

Stream	Set	Fe	Ti	V	Cr	Mg	Mn
<b>FPLS</b>	1	33575	26100	197.9	52.1	62450	331.4
<b>FPLS</b>	2	31500	24310	198.5	83.9	62350	332.6
<b>FPLS</b>	3	35050	25075	196	74	63425	331
<b>FPLS</b>	4	33725	24393	180	45	58150	296
<b>FPLS</b>	5	33450	26900	196	50	64425	331
<b>FPLS</b>	6	21920	27900	193	49	67450	310
<b>FPLS</b>	7	35150	27325	199	48	68500	323
<b>FPLS</b>	8	34600	26975	203	52	67450	330
<b>FPLS</b>	9	33700	24690	197	49	61875	319
<b>FPLS</b>	10	31375	23865	177	46	59175	294
<b>FPLS</b>	11	35100	25475	186	52	67175	301
<b>FPLS</b>	11	38725	28725	215	53	77400	352
<b>FPLS</b>	12	32675	24240	185	47	64750	302
<b>FPLS</b>	13	32400	24208	181	49	56750	323
<b>FPLS</b>	14	37075	27175	193	54	67500	321
<b>FPLS</b>	15	33775	25450	189	51	63025	314
<b>FPLS</b>	16	32775	26100	205	48	64350	341
<b>FPLS</b>	17	23495	28600	218	59	66100	364
<b>FPLS</b>	18	24588	27875	201	57	68175	334
<b>FPLS</b>	19	33460	25020	186	50	59820	305
<b>FE1RP</b>	D1-3	132.9	25725	195.9	58.9	61575	330.8
<b>FE1RP</b>	D2-3	<5	24820	193	75	63775	328
<b>FE1RP</b>	D4	<5	27400	207	52	66775	335
<b>FE1RP</b>	D3-7	<5	34025	206.2	53.9	86250	347.8
<b>FE1RP</b>	D1	<5	28175	219.5	58.7	71825	349.9
<b>FE1RP</b>	D4-11	<5	25200	189	51	66350	299
<b>FE1RP</b>	D4-11	<5	28000	213.8	53.7	76975	359.6
<b>FE1R</b>	1	13.5	27125	208.1	57.3	66625	353.7
<b>FE1R</b>	2	13.6	24995	196.3	72.5	63550	338
<b>FE1R</b>	3	40.5	26000	199.1	59.4	63500	331.5
<b>FE1R</b>	4	<5	30175	199.2	63.5	74075	337.1
<b>FE1R</b>	5	8.7	26425	198.1	51.2	63650	335.2
<b>FE1R</b>	6	5.9	27100	192.7	48.7	66350	312.1
<b>FE1R</b>	7	<5	28300	208.7	52.1	72575	352.5
<b>FE1R</b>	8	10	29500	223.3	58.1	74750	359

<b>FE1R</b>	9	5.6	25275	202.5	51.8	63550	326.5
<b>FE1R</b>	10	10.8	26400	196.6	51.9	59425	334
<b>FE1R</b>	11	<5	25150	190	54	67050	304
<b>FE1R</b>	11	103.2	27800	217.4	52.1	75225	356.4
<b>FE1R</b>	12	<5	26825	203	52.1	72750	339.7
<b>FE1R</b>	13	<5	25975	189.4	50.5	62550	340.5
<b>FE1R</b>	14	12.4	27425	198.5	54.1	69500	329.6
<b>FE1R</b>	15	23.5	26450	201.3	55.5	63275	334.2
<b>FE1R</b>	16	<5	29425	219	54	70300	366
<b>FE1R</b>	17	17.2	28575	216.5	56.8	65375	363.4
<b>FE1R</b>	18	<5	21550	163.8	44.2	53975	273.4
<b>FE1R</b>	19	18.4	28020	212.9	60.4	70340	349
<b>FE1O</b>	19	7	64	<5	<5	26	<5
<b>FE2R</b>	7	8	26475	203	52.4	67275	341.1
<b>FE2R</b>	8	<5	27450.0	205	55	68750	325
<b>FE2R</b>	10	<5	25150	186	49	58350	311
<b>FE2R</b>	11	<5	26650.0	202	57	70025	319
<b>FE2R</b>	19	5.80			52	62340	336
<b>FE2O</b>	19	15			<5	24	<5
<b>FE3R</b>	19	30	26530.0	200	47.9	60700	328
<b>FE3O</b>	19	1490	86	<5	<5	35	<5
<b>FE4O</b>	19	8997	19	<5	<5	25	<5
<b>FE5R</b>	18	2480.25	23673	175	104	63750	
<b>FE5O</b>	18	11365	49	<5	<5	69	
<b>FB</b>	2	106750	125	<5	<5	245	<5
<b>FB</b>	3	99125	427	<5	<5	943	<5
<b>FB1R</b>	1	65750	8393	66	17	19553	108
<b>FB1R</b>	2	75450	6025	48	21	13965	83
<b>FB1R</b>	3	79800	6525	51	21	15038	86
<b>FB1R</b>	4	47875	12763	90	23	29300	149
<b>FB1R</b>	5	19848	19270	141	34	44225	232
<b>FB1R</b>	6	13463	21100	154	38	48900	248
<b>FB1R</b>	7	76120	12875	79	19	31025	133
<b>FB1R</b>	8	63500	14078	107	27	34075	173
<b>FB1R</b>	9	62050	8688	69	15	20253	112
<b>FB1R</b>	10	49200	11483	83	18	24813	141
<b>FB1R</b>	11	70500	7578	55	15	18743	88
<b>FB1R</b>	11	54675	10353	82	19	19485	135
<b>FB1R</b>	12	31625	15350	114	28	34850	189

<b>FB1R</b>	13	40075	13293	99	26	30575	179
<b>FB1R</b>	14	62000	11798	86	23	28100	141
<b>FB1R</b>	15	23.5	26450	201.3	55.5	63275	334.2
<b>FB1R</b>	16	55650	12493	95	22	27725	158
<b>FB1R</b>	17	61075	8538	61	14	17348	100
<b>FB1R</b>	18	53775	9203	65	17	19663	107
<b>FB1R</b>	19	71260	5548	38	10	11382	61
<b>FB1O</b>		11440	6	<5	<5	18	
<b>FS1R</b>	1	102200	196	<5	<5	355	<5
<b>FS1R</b>	2	113275	100	<5	<5	167	<5
<b>FS1R</b>	3	100800	441	<5	<5	999	5
<b>FS1R</b>	4	91125	322	<5	<5	588	<5
<b>FS1R</b>	5	54400	611	<5	<5	1230	7
<b>FS1R</b>	6	99650	989	8	<5	2057	10
<b>FS1R</b>	7	138275	229	<5	<5	474	<5
<b>FS1R</b>	8	120025	330	<5	<5	747	<5
<b>FS1R</b>	9	112325	220	<5	<5	431	<5
<b>FS1R</b>	10	91200	2313	18	<5	5545	28
<b>FS1R</b>	11	114825	43	<5	<5	85	<5
<b>FS1R</b>	11	110875	273	<5	<5	589	<5
<b>FS1R</b>	12	86750	2369	18	<5	5638	29
<b>FS1R</b>	13	98600	439	<5	<5	901	<5
<b>FS1R</b>	14	45900	95	<5	<5	192	<5
<b>FS1R</b>	15	92275	2708	20	<5	5985	33
<b>FS1R</b>	16	97625	1816	16	<5	4198	24
<b>FS1R</b>	17	98750	176	<5	<5	325	<5
<b>FS1R</b>	18	96375	258	<5	<5	453	<5
<b>FS1R</b>	19	101640	58	<5	<5	85	<5
<b>FS1O</b>	19	8777	64	<5	<5	28	<5
<b>FS2R</b>	18	76225	16	<5	<5	54.9	
<b>FS2R</b>	19	84240	13	<5	<5	34.2	<5
<b>FS2O</b>	18	4110	7	<5	<5	28	
<b>FS2O</b>	19	6850	<5	<5	<5	24	<5
<b>FS3R</b>	18	33875	<5	<5	<5	15	
<b>FS3R</b>	19	64100	6	<5	<5	23.20	<5
<b>FS3O</b>	18	86	<5	<5	<5	<5	
<b>FS3O</b>	19	1838	<5	<5	<5	26	<5
<b>FS4R</b>	18	7233	<5	<5	<5	15	
<b>FS4R</b>	19	17460	6	<5	<5	28.60	<5

<b>FS4O</b>	18	<5	<5	<5	<5	14	
<b>FS4O</b>	19	16.600	<5	<5	<5	36	<5
<b>FS5R</b>	18	205	<5	<5	<5	<15.4	
<b>FS5R</b>	19	1621	<5	<5	<5	<20.1	<5
<b>FS5O</b>	18	<5	<5	<5	<5	<5	
<b>FS5O</b>	19	<5	<5	<5	<5	31	<5
<b>FS6R</b>	18	23	<5	<5	<5	<17.3	
<b>FS6R</b>	19	387	<5	<5	<5	20.10	<5
<b>FS6O</b>	18	<5	<5	<5	<5	<5	
<b>FS6O</b>	19	<5	<5	<5	<5	13	<5
<b>FS7R</b>	18	<5	<5	<5	<5	<8.3	
<b>FS7R</b>	19	72	<5	<5	<5	<29.3	<5
<b>FS7O</b>	18	<5	<5	<5	<5	<5	
<b>FS7O</b>	19	<5	<5	<5	<5	19	<5

## Titanium Circuit Large Pilot-Scale Plant Assay Results

Stream	Set	Fe	Ti	V	Cr	Mg	Mn
<b>TPLS</b>	1	<5	25800	224	71	61900	359
<b>TPLS</b>	2	40.9	25925	198	81	66450	330
<b>TPLS</b>	3	13.1	25125	186.9	66.6	62975	311.9
<b>TPLS</b>	4	<5	32725	235	65	79725	393
<b>TPLS</b>	6	<5	26525	214.4	56.2	66500	334.3
<b>TPLS</b>	7	<5	26075	234.4	57.3	64875	376.7
<b>TPLS</b>	8	<5	25050	193.5	48.4	63400	323.9
<b>TPLS</b>	9	<5	27400	199	48	69975	313
<b>TPLS</b>	9	<5	27400	199	48	69975	313
<b>TPLS</b>	11	11.8	27650	78.2	20.6	51600	130.5
<b>TPLS</b>	12	<5	31025	69	17	48250	118
<b>TPLS</b>	13	<5	35000	119.5	24.4	60400	172.3
<b>TPLS</b>	14	<5	25050	195	49	67050	321
<b>TPLS</b>	15	<5	26825	200.2	52.8	71300	338.2
<b>TPLS</b>	16	<5	26150	194	54	66600	312
<b>TPLS</b>	17	7.5	26800	225	54.4	67375	344.7
<b>TPLS</b>	18	<5	27225	198.9	54.06	69575	323.9
<b>TPLS</b>	19	6.9	28125	221.9	57.9	69275	371.7
<b>TPLS</b>	20	9.07	28425	210.8	58.4	69725	400.25
<b>TPLS</b>	21	14.4	25400	203	54.1	62675	345.5
<b>TPLS</b>	22	9.6	24960	195.1	50.8	61050	324.8
<b>TPLS</b>	23	<5	26900	178	44	63350	296
<b>TPLS</b>	24	<5	29825	188	49.7	67625	311.3
<b>TPLS</b>	25	<5	21038	185	50.5	63825	317.7
<b>TE1R</b>	1	<5	59	84	92	63425	185
<b>TE1R</b>	2	<5	48.4	28.2	69.9	66075	153.7
<b>TE1R</b>	3	<5	49.1	60	67	60950	189
<b>TE1R</b>	4	<5	9135	295	57	79650	382
<b>TE1R</b>	6	<5	107	79.6	51	64700	198
<b>TE1R</b>	7	15.5	47.4	139.1	50.8	67350	257
<b>TE1R</b>	8	<5	51.7	122	45	64000	232
<b>TE1R</b>	9	<5	47	185.1	52	70200	285
<b>TE1R</b>	9	<5	47	185	52	70200	285
<b>TE1R</b>	11	<5	104	167	43	61450	250
<b>TE1R</b>	12	<5	173	174	22	52625	210
<b>TE1R</b>	13	9.6	221.8	88.9	20.8	50000	137.9
<b>TE1R</b>	14	<5	164	64	17	48250	111

<b>TE1R</b>	15	<5	116.2	63.3	37.6	54075	152.2
<b>TE1R</b>	16	5.39	127.2	96.03	50.72	69475	217.4
<b>TE1R</b>	17	<5	73.2	123.2	50.8	68550	251.5
<b>TE1R</b>	18	<5	66.63	104.8	52.25	71575	218.4
<b>TE1R</b>	19	<5	30.6	62.9	48.8	67325	202
<b>TE1R</b>	20	<5	97.22	129.1	55.65	71375	290.75
<b>TE1R</b>	21	<5	51	192	52	66350	307
<b>TE1R</b>	22	<5	46	191	49	62875	272
<b>TE1R</b>	23	<5	2720	427	46	65600	466
<b>TE1R</b>	24	<5	45.1	289.4	46.7	62750	300.5
<b>TE1R</b>	25	<5	63	116.2	42.4	64225	211.1
<b>TE10</b>	25	<5	1311	32.80	<5	37	20
<b>TE2R</b>	25	15.80	51.3	292	45	65260	311
<b>TE20</b>	25	<5	1180	49.90	<5	34	37
<b>TE3R</b>	25	<5	85	392	46	65070	388
<b>TE30</b>	25	<5	1420	52.90	<5	30	48
<b>TE4R</b>	25	<5	2517	395	49	68340	441
<b>TE40</b>	25	<5	3100	13.0	<5	48	22
<b>TB</b>	1	<5	38350	1414	40	33100	203
<b>TB</b>	2	22.8	37725	117.7	42.8	34725	201.8
<b>TB</b>	3	7.3	35825	109.2	33.7	31475	184.9
<b>TB</b>	4	<5	44925	135.4	36.3	41325	231.8
<b>TB</b>	6	<5	36150	117	29	34700	194
<b>TB</b>	7	<5	36575	132.3	30	34675	222.7
<b>TB</b>	8	<5	37675	113.4	24	33250	210
<b>TB</b>	9	<5	39725	123	27	36800	197
<b>TB</b>	11	<5	40875	71	16	24238	121
<b>TB</b>	12	<5	42500	67	15	21788	120
<b>TB</b>	13	<5	43925	100.4	15.7	20122.5	130.8
<b>TB</b>	14	<5	37975	94.1	19.2	20840	152.7
<b>TB</b>	15	5.9	40475	115.2	27.1	28625	193.2
<b>TB</b>	16	<5	37875	108	26	28750	175
<b>TB</b>	17	<5	36075	123.5	23.5	26500	175
<b>TB</b>	18	5.96	43300	105.6	27.15	28850	165.1
<b>TB</b>	19	<5	41150	122.9	27	29500	203.9
<b>TB</b>	20	<5	40700	120.4	28.5	29800	225.5
<b>TB</b>	21	<5	40900	116.1	25.3	28075	191.5
<b>TB</b>	22	10.4	39450	120.3	30.4	28450	201.9
<b>TB</b>	23	<5	46225	56.1	7.1	3092	67.3

<b>TB</b>	24	<5	35625	131.3	29.7	31100	206
<b>TB</b>	25	<5	38400	108.2	24.4	26425	178
<b>TB1R</b>	1	<5	16313	288	72	51750	391
<b>TB1R</b>	2	<5	11212.5	307.7	72.9	59000	408.6
<b>TB1R</b>	3	<5	15215	280.3	65.2	54050	382.9
<b>TB1R</b>	4	12.8	13240	344.2	68.3	68675	460.2
<b>TB1R</b>	6	<5	32050	261	48	45575	408
<b>TB1R</b>	7	<5	36200	282.3	47.9	44625	485.9
<b>TB1R</b>	8	<5	27100	290.9	35.4	42375	477.7
<b>TB1R</b>	9	<5	36550	241	36	45975	404
<b>TB1R</b>	11	6	29800	191	32	40150	306
<b>TB1R</b>	12	<5	15343	119	18	44125	157
<b>TB1R</b>	13	<5	29650	130.4	19.9	42150	183.2
<b>TB1R</b>	14	6.1	31850	115.7	19.1	32075	201.8
<b>TB1R</b>	15	<5	40000	174	31.3	42575	334
<b>TB1R</b>	16	17.97	36375	182.4	35.69	50200	335.2
<b>TB1R</b>	17	<5	35475	247.5	35.7	38150	427.8
<b>TB1R</b>	18	<5	32950	300	37	37750	501
<b>TB1R</b>	19	5.8	25750	499.7	39.1	35390	692.1
<b>TB1R</b>	20	<5	35250	440.7	39.89	38150	695
<b>TB1R</b>	21	6	43300	106	27	28850	165
<b>TB1R</b>	22	<5	27225	199	54	69575	324
<b>TB1R</b>	23	<5	29575	276	34	37450	456
<b>TB1R</b>	24	<5	25100	330	40	38400	502
<b>TB1R</b>	25	<5	22140	341	42	39850	517
<b>TB1O</b>	25	<5	3650	6.1	<5	80	13
<b>TB2R</b>	25	<5	37510	188	31	31730	334
<b>TB2O</b>	25	<5	3475	<5	<5	79	7
<b>TS1R</b>	1	<5	30175	104	32	18595	181
<b>TS1R</b>	2	<5	32925	140.2	28.8	21780	199.2
<b>TS1R</b>	3	<5	30650	132.5	30.1	22107.5	196.3
<b>TS1R</b>	4	<5	49275	78	12	10088	116
<b>TS1R</b>	6	<5	46650	67.3	11.4	7050	100.2
<b>TS1R</b>	7	<5	46000	62.3	9.9	7237.5	94.5
<b>TS1R</b>	8	<5	42325	54.9	8.5	6355	89
<b>TS1R</b>	9	<5	52500	89	10	7250	111
<b>TS1R</b>	11	11	51625	54	9	6133	88
<b>TS1R</b>	12	<5	42675	59	10	13493	92
<b>TS1R</b>	13	<5	28675	130.1	18.9	40400	182.2

<b>TS1R</b>	14	<5	42625	47	5	6420	49
<b>TS1R</b>	15	<5	45100	47	7.4	7025	57.4
<b>TS1R</b>	16	5.68	48725	45.63	8.54	4375	54.58
<b>TS1R</b>	17	<5	49275	91.5	11.7	7987.5	106.3
<b>TS1R</b>	18	15.76	45725	50.03	9.58	5092.5	75.39
<b>TS1R</b>	19	35.1	47400	63.5	10	4545	93.3
<b>TS1R</b>	20	<5	43125	52.88	7.81	3442.5	75.71
<b>TS1R</b>	21	127.5	47975	68.7	8.2	3645	106.2
<b>TS1R</b>	22	<5	48125	59	10	4475	80
<b>TS1R</b>	23	<5	46225	56	7	3092	67
<b>TS1R</b>	24	<5	47850	61.5	9.9	5060	83.2
<b>TS1R</b>	25	<5	47275	70	12	6568	114.6
<b>TS10</b>	25	<5	2889	<5	<5	34	<5
<b>TS2R</b>	25	<5	46980	51.3	9.8	3974	67
<b>TS20</b>	25	<5	2630	<5	<5	29	<5
<b>TS3R</b>	25	<5	41430	34	8	1494.00	26
<b>TS30</b>	25	<5	2404	<5	<5	29	<5
<b>TS4R</b>	25	<5	32060	22	7	101.70	<5
<b>TS40</b>	25	<5	2396	<5	<5	25	<5
<b>TS5R</b>	25	<5	25600	17	<5	<48.5	<5
<b>TS50</b>	25	<5	2494	<5	<5	25	<5
<b>TS6R</b>	25	<5	18410	12	<5	24.00	<5
<b>TS60</b>	25	25.4	2301.000	<5	<5	137	<5
<b>TS7R</b>	25	<5	12930	<8.5	<5	<25.8	<5
<b>TS70</b>	25	7.1	1832.0	<5	<5	46	<5
<b>TS8R</b>	25	<5	7779	<5.2	<5	<28.5	<5
<b>TS80</b>	25	7.100	1328.000	<5	<5	37	<5

*Appendix 14: XRF and ICP-OES Analyses by AGAT Laboratories on Titanium Dioxide Products*

# CERTIFICATE OF ANALYSIS

**AGAT WORK ORDER:** 17T186175  
**PROJECT:** PRO 16-05  
**CLIENT NAME:** PROCESS RESEARCH ORTECH INC.  
**ATTENTION TO:** ABDUL HALIM; DEEPAK ARIYANAYAGAM  
**DATE RECEIVED:** Feb 10, 2017  
**DATE SAMPLED:** Feb 09, 2017  
**DATE REPORTED:** Feb 15, 2017

**PACKAGE INFORMATION:**

**Work Sheet Name** X01      **Sample T Package Name** Other (201-378) Sodium Peroxide Fusion - ICP-OES/ICP-MS Finish

(201-378) Sodium Peroxide Fusion - ICP-OES/ICP-MS Finish

Sample Id	Sample Description	Analyte:	Ag ppm	Al %	As ppm	B ppm	Ba ppm	Be ppm	Bi ppm	Ca %	Cd ppm	Ce ppm	Co ppm	Cr %	Cs ppm	Cu ppm	Dy ppm	Er ppm	
§182074	17-0022 - T-16-05-Com	Unit:	1	0.01	30	20	0.5	5	0.1	0.05	0.2	0.1	0.5	0.005	0.1	5	0.05	0.05	
§182076	17-0024 - T16-05-TP#15	RDL:	<1	0.82	<30	<20	<0.5	<5	<0.1	0.09	<0.2	<0.1	<0.5	<0.005	44.6	<5	<0.05	<0.05	
§182077	17-0025 - T16-05-TP#18		<1	0.12	<30	<20	17.2	<5	<0.1	0.08	<0.2	<0.1	0.8	<0.005	<0.1	<5	<0.05	<0.05	
Comments:			RDL - Reported Detection Limit																
		Analyte:	Eu ppm	Fe %	Ga ppm	Gd ppm	Ge ppm	Hf ppm	Ho ppm	In ppm	K %	La ppm	Li ppm	Lu ppm	Mg %	Mn ppm	Mo ppm	Nb ppm	
§182074	17-0022 - T-16-05-Com	Unit:	0.05	0.01	0.01	0.05	1	1	0.05	0.2	0.05	0.1	10	0.05	0.01	10	2	1	
§182076	17-0024 - T16-05-TP#15	RDL:	<0.05	<0.01	0.82	<0.05	<1	<1	<0.05	<0.2	<0.05	<0.1	<10	<0.05	<0.01	<10	<2	1	
§182077	17-0025 - T16-05-TP#18		<0.05	<0.01	0.15	<0.05	<1	<1	<0.05	<0.2	<0.05	<0.1	<10	<0.05	<0.01	<10	<2	106	
		Analyte:	Nd ppm	Ni ppm	P %	Pb ppm	Pr ppm	Rb ppm	S %	Sb ppm	Sc ppm	Si %	Sm ppm	Sn ppm	Sr ppm	Ta ppm	Tb ppm	Th ppm	
§182074	17-0022 - T-16-05-Com	Unit:	0.1	5	0.01	5	0.05	0.2	0.01	0.1	5	0.01	0.1	1	0.1	0.5	0.05	0.1	
§182076	17-0024 - T16-05-TP#15	RDL:	<0.1	<5	0.06	<5	<0.05	0.6	<0.01	<0.1	<5	0.86	<0.1	<1	<0.1	1.9	<0.05	<0.1	
§182077	17-0025 - T16-05-TP#18		<0.1	<5	0.3	<5	<0.05	<0.2	<0.01	0.1	<5	0.01	<0.1	<1	<0.1	7.4	<0.05	<0.1	
		Analyte:	Ti %	Tl ppm	Tm ppm	U ppm	V ppm	W ppm	Y ppm	Yb ppm	Zn ppm								
§182074	17-0022 - T-16-05-Com	Unit:	0.01	0.5	0.05	0.05	5	1	0.5	0.1	5								
§182076	17-0024 - T16-05-TP#15	RDL:	58.7	<0.5	<0.05	<0.05	<5	<1	<0.5	<0.1	<5								
§182077	17-0025 - T16-05-TP#18		59.3	<0.5	<0.05	<0.05	23	1	<0.5	<0.1	15								

Contact:

AGAT Laboratories

**Ontario Region**

**Main Office**

5835 Coopers Avenue

Mississauga, Ontario

L4Z 1Y2

Tel: 905.712.5100

Fax: 905.712.5122

*Appendix 15: XRF and ICP-OES Analyses by AGAT Laboratories on NRRI/PRO Titanium Dioxide Product without Surface Modifiers*

# CERTIFICATE OF ANALYSIS

**AGAT WORK ORDER:** 17T198708  
**PROJECT:** 16-05  
**CLIENT NAME:** PROCESS RESEARCH ORTECH INC.  
**ATTENTION TO:** ABDUL HALIM, DEEPAK ARIYANAYAGAM  
**DATE RECEIVED:** Mar 23, 2017  
**DATE SAMPLED:** Mar 22, 2017  
**DATE REPORTED:** Apr 04, 2017

**PACKAGE INFORMATION:**

<b>Work Sheet Name</b>	<b>Sample T Package Name</b>
X01	Other (201-378) Sodium Peroxide Fusion - ICP-OES/ICP-MS Finish
X02	Other (201-099) Industrial Metals Package, ICP/ICP-MS finish

(201-378) Sodium Peroxide Fusion - ICP-OES/ICP-MS Finish

Analyte:	Ag	Al	As	B	Ba	Be	Bi	Ca	Cd	Ce	Co	Cr	Cs	Cu	Dy	Er
Unit:	ppm	%	ppm	ppm	ppm	ppm	ppm	%	ppm	ppm	ppm	%	ppm	ppm	ppm	ppm
Sample Description	1	0.01	30	20	0.5	5	0.1	0.05	0.2	0.1	0.5	0.005	0.1	5	0.05	0.05
17-0074 - T16-05-TP#29A PPT	<1	<0.01	<30	<20	70.3	<5	<0.1	<0.05	<0.2	<0.1	0.5	<0.005	<0.1	311	<0.05	<0.05
	Eu	Fe	Ga	Gd	Ge	Hf	Ho	In	K	La	Li	Lu	Mg	Mn	Mo	Nb
	ppm	%	ppm	ppm	ppm	ppm	ppm	ppm	%	ppm	ppm	ppm	%	ppm	ppm	ppm
	0.05	0.01	0.01	0.05	1	1	0.05	0.2	0.05	0.1	10	0.05	0.01	10	2	1
	<0.05	<0.01	0.11	<0.05	<1	<1	<0.05	<0.2	<0.05	<0.1	<10	<0.05	0.01	<10	<2	101
	Nd	Ni	P	Pb	Pr	Rb	S	Sb	Sc	Si	Sm	Sn	Sr	Ta	Tb	Th
	ppm	ppm	%	ppm	ppm	ppm	%	ppm	ppm	%	ppm	ppm	ppm	ppm	ppm	ppm
	0.1	5	0.01	5	0.05	0.2	0.01	0.1	5	0.01	0.1	1	0.1	0.5	0.05	0.1
	<0.1	<5	0.01	<5	<0.05	<0.2	0.03	<0.1	<5	0.06	<0.1	<1	2.1	3.7	<0.05	<0.1
	Ti	Tl	Tm	U	V	W	Y	Yb	Zn							
	%	ppm	ppm	ppm	ppm	ppm	ppm	ppm	ppm							
	0.01	0.5	0.05	0.05	5	1	0.5	0.1	5							
	59.9	<0.5	<0.05	<0.05	14	1	<0.5	<0.1	43							

Comments: RDL - Reported Detection Limit

Contact:

AGAT Laboratories

**Ontario Region**

**Main Office**

5835 Coopers Avenue

Mississauga, Ontario

L4Z 1Y2

Tel: 905.712.5100

Fax: 905.712.5122

*Appendix 16: High-Level CAPEX Estimate for Beneficiation Plant***Upfront Expenses (Yr 1 Expenses)**

<b>Engineering / Permitting / Development and Commissioning</b>		
Land Acquisition		N/A
Permitting		N/A
Site Prep / Service Utilities	\$	2,800,000
Development Fees		N/A
Administration / Misc.		N/A
<b>Total</b>	<b>\$</b>	<b>2,800,000</b>

**Upfront Cost Assumptions: Equipment**

<b>Equipment Costs</b>		
<i>Pit Equipment (assume drilling and blasting contracted out)</i>		
(3) 50 Ton Load Trucks	\$	4,380,000
(3) Loaders	\$	3,870,000
(1) Dozer	\$	2,000,000
(1) Grader	\$	1,000,000
Other	\$	1,000,000
<b>Total Pit Equipment Costs</b>	<b>\$</b>	<b>12,250,000</b>
<i>Mineral Beneficiation</i>		
Primary Crusher		203,000
Secondary Crusher		508,000
Primary Grinding		1,250,000
Beneficiation Unit 1		120,000
Concentrate Regrinding Mill		2,650,000
Beneficiation Unit 2		140,000
50-foot diameter tailings thickener		1,000,000
25-foot diameter ilmenite concentrate thickener		750,000
Ilmenite Slurry Tank 20' x 20' (4 Hrs.)		100,000
Ilmenite Vacuum disk filters		300,000
20-foot diameter magnetite concentrate thickener		650,000
Magnetite Slurry Tank		100,000
Magnetite Vacuum Disc Filter		150,000
<b>Total Process Equipment Costs</b>	<b>\$</b>	<b>7,921,000</b>

Ancillary Equipment (60% of Equip)	\$	4,752,600
Process Control Systems (10% of Equip)	\$	792,100
Safety Design and Control Systems (10% of Equip)	\$	792,100
<b>Total Process Equipment Investment</b>	<b>\$</b>	<b>14,257,800</b>
<i>Facilities</i>		
Pit Service Building	\$	1,000,000
Concentrator Building	\$	2,000,000
Pit development and pre-stripping	\$	2,000,000
Tailings Basin Development	\$	2,000,000
<b>Total Facilities Costs</b>	<b>\$</b>	<b>7,000,000</b>

### **Upfront Cost Assumptions: Engineering**

<b>Engineering / Construction</b>		
Construction Cost Est. (39% of Equip)	\$	3,089,190
General Contractor (5%)	\$	396,050
Engineering - Mechanical (15%)	\$	1,188,150
Engineering - Electrical (5%)	\$	396,050
Engineering - Civil and Structural (13%)	\$	1,029,730
Contingency (10%)	\$	792,100
<b>Total Installed Cost</b>	<b>\$</b>	<b>6,891,270</b>

### **Upfront Cost Assumptions: Facilities**

<b>Administration / Facilities / Office</b>		
Admin. Office / Restrooms / Lunchrooms	\$	400,000
Warehouse / Shop	\$	400,000
Roads / Infrastructure	\$	500,000
Mobile Equipment	\$	280,000
Security	\$	100,000
<b>Total Admin</b>	<b>\$</b>	<b>1,680,000</b>

<b>Total Capital Investment</b>	<b>\$</b>	<b>44,879,070</b>
---------------------------------	-----------	-------------------

*Appendix 17: High-Level CAPEX Estimate for Hydrometallurgical Plant*

PROJECT COST ESTIMATE SUMMARY SHEET								
60,000 TPA TiO <sub>2</sub> PRODUCTION FACILITY								
Ore with 40% Ti								
<b>1.0 DIRECT COST</b>								
AREA	DESCRIPTION				MATERIAL	LABOUR	TOTAL	
200	ORE LEACHING				\$3,702,900	\$1,296,100	\$4,999,000	
280	OXIDATION				\$4,553,500	\$1,593,800	\$6,147,300	
300	SX STAGE I-Fe RECOVERY				\$3,597,000	\$1,210,800	\$4,807,800	
400	SX STAGE II-Ti RECOVERY				\$2,460,700	\$861,300	\$3,322,000	
600	WATER EVAPORATION SYSTEM				\$3,865,300	\$732,900	\$4,598,200	
700	TiO <sub>2</sub> PRECIPITATION				\$1,964,100	\$687,400	\$2,651,500	
750	TiO <sub>2</sub> CALCINING AND GRINDING				\$3,839,600	\$1,343,900	\$5,183,500	
1000	EVAPORATION AT IRON CIRCUIT				\$3,055,000	\$549,300	\$3,604,300	
1100	PYROHYDROLYSIS FOR Fe <sub>2</sub> O <sub>3</sub>				\$26,071,000	\$4,424,900	\$30,495,900	
1150	MgO PYROHYDROLYSIS				\$4,320,000	\$852,000	\$5,172,000	
1200	Fe <sub>2</sub> O <sub>3</sub> GRINDING				\$2,737,000	\$958,000	\$3,695,000	
1350	WASTE WATER TREATMENT PLANT				\$1,325,200	\$463,900	\$1,789,100	
1400	UTILITIES GENERATION				\$3,481,000	\$1,218,400	\$4,699,400	
1500	SITE WORKS				\$810,000	\$283,500	\$1,093,500	
1600	WAREHOUSE-LAB -MOBILE EQUIPMENT				\$1,640,000	\$399,000	\$2,039,000	
					<b>SUBTOTAL DIRECT COST:</b>	<b>\$70,635,800</b>	<b>\$17,999,900</b>	<b>\$84,298,000</b>
<b>2.0 INDIRECT COST</b>								
					ENGINEERING :	12%	\$10,116,000	
					OWNER COST	1.0%	\$843,000	
					SPARE PARTS	2%	\$1,413,000	
					CONSTRUCTION MANAGEMENT	3%	\$2,529,000	
					TRANSPORTATION	4%	\$2,825,000	
					CHEMICALS INITIAL LOAD	2%	\$1,686,000	
					<b>SUBTOTAL INDIRECT COST:</b>		<b>\$19,412,000</b>	
<b>3.0 PROJECT COST</b>								
					<b>TOTAL DIRECT AND INDIRECT COST</b>		<b>\$103,710,000</b>	
					CONTINGENCY (%):	15%	\$15,557,000	
					<b>TOTAL CAPITAL INVESTMENT :</b>		<b>\$119,267,000</b>	
ANDEBURG CONSULTING SERVICES INC.		TITLE:						
PROCESS RESEARCH ORTECH		60,000 TPA TITANIUM DIOXIDE PRODUCTION FACILITY		Page:		1		
		CAPEX SUMMARY		Rev.:		0		
Prepared By: E. Burga		Client Review:		Date:		08/03/2017		

Appendix 18: High-Level OPEX Estimate for 60,000 TPA TiO<sub>2</sub> Plant

PRO							Rev	2
OPERATING COST FOR BASE CASE							By:	J. Chen
60,000.00 Tonnes per Year of TiO <sub>2</sub> (Ore with 40% Ti-Pyrophydrolysis)							Date	8-Mar
Operating Days per year	330	Days	Ilm. Con Tonnage	226356.3				
<b>1.0 RAW MATERIAL</b>							<b>Yearly Cost</b>	<b>Cost Per tonne</b>
				<b>Daily Consumption (in Tonnes)</b>	<b>Unit Cost (\$/Tonne)</b>	<b>Total</b>		
Mining and Beneficiation	28.6	24	Mining	685.9	125	\$ 85,741		
<b>Sub Total Raw Material Cost</b>						<b>\$ 85,741</b>	<b>\$ 28,294,541</b>	
<b>2.0 CHEMICALS</b>								
				<b>Daily Consumption (in Tonnes)</b>	<b>Unit Cost (\$/Tonne)</b>	<b>Total</b>		
Solvent 1				0.03	2500	\$ 75		
Solvent 2				0.02	2500	\$ 48		
Solvent 3				0.06	625	\$ 36		
Solvent 4				0.02	625	\$ 13		
Solvent 4				0.1	1000	\$ 100		
MgO				1.40	300	\$ 420		
HCl				2.6	300	\$ 780		
NH4				0.18	300	\$ 54		
Other (cement)				5.82	100	\$ 582		
Flocculants				10.00	300	\$ 3,000		
NaOH**				0.18	320	\$ 58		
<b>Sub Total Chemicals</b>						<b>\$ 5,165</b>	<b>\$ 1,704,582</b>	
<b>3.0 CONSUMMABLES</b>								
Spare Parts (As % of equipment cost)	2%					\$ 3,318		
Grind Media equiv (total tonnes x allocation)					\$ 67.40	\$ 5.00	\$ 337	
Packaging (total tonnes x allocation)					187.5	3	\$ 563	
Mobile equipment					2	150	\$ 300	
Office Supplies					1	120	\$ 120	
Plant supplies					1	300	\$ 300	
<b>Sub-Total Consumables</b>						<b>\$ 4,938</b>	<b>\$ 1,629,433</b>	
<b>4.0 LABOUR</b>								
<b>Operations</b>	<b># of Employees</b>	<b>Shifts</b>	<b>Total employees</b>	<b>Social Charges</b>	<b>%</b>	<b>Yearly Salary</b>	<b>S/Day</b>	
<b>4.1 Management</b>								
Plant Manager	1	1	1	135%	100%	\$ 120,000	\$ 490.91	
Superintendents	2	3	6	135%	100%	\$ 100,000	\$ 2,454.55	
Engineers	3	3	9	135%	100%	\$ 80,000	\$ 2,945.45	
Technician	3	3	9	135%	100%	\$ 70,000	\$ 2,577.27	
Quality Control	2	1	2	135%	100%	\$ 50,000	\$ 409.09	
<b>4.2 Labour</b>								
Leaching	2	4	8	135%	100%	\$ 50,000	\$ 1,636.36	
Solvent Extraction	2	4	8	135%	100%	\$ 50,000	\$ 1,636.36	
Precipitation	1	4	4	135%	100%	\$ 50,000	\$ 818.18	
Pyrohydrolysis	1	4	4	135%	100%	\$ 50,000	\$ 818.18	
Product Handling	2	4	8	135%	100%	\$ 50,000	\$ 1,636.36	
Services	2	4	8	135%	100%	\$ 50,000	\$ 1,636.36	
<b>4.3 Administration</b>								
Manager	1	1	1	135%	100%	\$ 110,000	\$ 450.00	
Offices	3	1	3	135%	100%	\$ 60,000	\$ 736.36	
Logistic and Warehouse	2	1	2	135%	100%	\$ 70,000	\$ 572.73	
Specialist	1	1	1	135%	100%	\$ 80,000	\$ 327.27	
Services	1	1	1	135%	100%	\$ 30,000.00	\$ 122.73	
						74		
<b>Sub Total Labour Administ &amp; Operations</b>						<b>\$ 19,268</b>		
<b>4.4 Maintenance</b>								
Supervisors	2	1	2	135%	1	\$ 80,000.00	\$ 654.55	
Mechanical	3	3	9	135%	1	\$ 60,000.00	\$ 2,209.09	
Instrument/Electrical	2	3	6	135%	1	\$ 60,000.00	\$ 1,472.73	
Non-skilled	2	3	6	135%	1	\$ 30,000.00	\$ 736.36	
						23		
<b>Sub Total Maintenance</b>						<b>\$ 5,072.73</b>		
<b>Total Number Operators</b>			<b>97</b>					
<b>Sub Total Labour</b>						<b>\$ 24,341</b>	<b>\$ 8,032,500</b>	
<b>5.0 UTILITIES</b>								
Power			Kw/h	3600	\$/Kwh	\$0.08	\$ 6,912	
Fuel HCl recovery	24		MM BTU/h	76	\$/Million BTU	\$3.50	\$ 6,387	
Fuel Plant operations	24		MM BTU/h	130	\$/Million BTU	\$3.50	\$ 10,909	
Water			m3/day	150	\$/m <sup>3</sup>	\$0.95	\$ 143	
<b>Sub Total Utilities</b>						<b>\$ 24,351</b>	<b>\$ 8,035,754</b>	
<b>6.0 TOTAL DAILY OPERATING COST</b>						<b>\$ 144,536</b>		
<b>Number of Operating Days Per Year</b>						<b>\$ 330</b>		
<b>Total Annual Operating Cost</b>						<b>\$ 47,696,810</b>		
<b>Total Cost Per tonne</b>						<b>\$ 794.95</b>		
<b>7.0 IRON PROD CREDIT</b>			TPA	82088	\$/ton	60	\$ 4,925,280	
<b>9.0 TIO2 product</b>				60000		2500	\$150,000,000.00	
<b>FINAL ADJUSTED COST PER TONNE</b>						<b>\$ 712.86</b>		
Notes:								
1.- Chemicals and Consummables to be adjusted at completion of engineering and process confirmation								
2.- Utilities will be confirmed after Basic Engineering study and usage confirmation with major equipment suppliers.								

*Appendix 19: University of Minnesota Duluth Center for Economic Development (CED) Titanium Product Marketing Study*



**Market Analysis – NRRI TiO<sub>2</sub> Project**

May 12, 2017

**11 East Superior St, Suite 210  
Duluth, MN 55802  
218-726-7298  
[www.umdced.com](http://www.umdced.com)**

Researched and Prepared by: Brooklyn Pouti  
*UMD – CED Student Research Assistant*

Researched and Edited by: Jim Croyle  
*UMD - CED Business Consultant*



*The Minnesota Small Business Development Center program is funded by the U.S. Small Business Administration (SBA), the Minnesota Department of Employment and Economic Development, and the sponsors of regional and local centers. SBA's funding is not an endorsement of any products, opinions or services. Small Business Development Center services are provided without discrimination as to race, gender, color, creed, religion, disability, national origin, marital status, or sexual orientation. Upon prior request to the Small Business Development Center office from which services are sought, arrangements will be made to reasonably accommodate persons with disabilities.*

Table of Contents:

1. Project Description
2. Project Objective
3. Project Background
4. Project Goal
5. Market Analysis Scope
6. Market questions to be answered
7. Critical Knowns
8. Critical Unknowns
9. Summary of Market Study
10. Production Opportunities
11. Supply chain diagram
12. Appendix – research detail information

**Project Description:** TiO<sub>2</sub> extraction from Minnesota Based Ilmenite

**Project Objective:** To determine if using a new production process, is there a viable and profitable commercial market to produce high-purity TiO<sub>2</sub> (titanium dioxide) in Minnesota, and using Minnesota Ilmenite.

**Project Background** (*provided by NRRI*): The mineral (ilmenite) is an iron-titanium oxide and is found in Minnesota's Duluth Complex (MDC). The MDC is a large area in northeastern Minnesota that contains significant deposits of ilmenite that can be a strategic source of TiO<sub>2</sub> for pigment production and other uses, and titanium metal recovery.

**Project Goal:** NRRI has partnered with Process Research Ortech (PRO) to prove the technical feasibility of producing high purity titanium product(s) from Minnesota ilmenite using proprietary technologies of PRO.

**Market Analysis Scope:**

1. Determine the current TiO<sub>2</sub> markets in terms of supply (producers) and demand (end-users)
2. Determine supply and demand trends in the TiO<sub>2</sub> markets
3. Determine the outlook for TiO<sub>2</sub> supply and demand (i.e. end use products by TiO<sub>2</sub> type)
4. Project the most likely potential market(s) for high-purity TiO<sub>2</sub> produced

**Market questions to be answered:**

1. What is the high-purity TiO<sub>2</sub> product worth (i.e. *sale price*) in the market?
2. Will there be enough demand in the market vs. the new supply (i.e. new supply of high purity TiO<sub>2</sub>)?
3. What is the current supply of TiO<sub>2</sub> by purity level in the market, and in terms of application and industries?
4. What are the other potential uses for high purity TiO<sub>2</sub>?
5. What target purity level of TiO<sub>2</sub> is considered good (i.e. what target purity level to consider)?
6. What purity levels of TiO<sub>2</sub> does each specific industries/applications require?
7. How are we going to differentiate ourselves from the current market players? How can we add value? What is our competitive advantage?
8. What level of market penetration (i.e. quantity level) should we target?
9. What are the closet potential markets to us (Minnesota Duluth Complex)?

**Critical Knowns:**

1. In the USA, ~80% of all TiO<sub>2</sub> produced is used in the Paints/Coatings, and the Plastics industries (~95% if include Paper and Printing Inks)
2. In the USA, ~8% of all TiO<sub>2</sub> produced is used for a variety of "other" items (i.e. pharma, food, printing inks, cosmetics, etc.)
3. The Chemours Company is currently the lowest cost producer, and the world's largest supplier of TiO<sub>2</sub> (~17% of mkt)
4. PPG and Sherwin-Williams are the largest producers of paints (~25% of total market)
5. Price of TiO<sub>2</sub> is expected to continue to fall modestly over the next five years (i.e. due to cost pressures across the supply chain)
6. PRO (a technology company) has developed a less expensive process to produce a high purity TiO<sub>2</sub>
7. PRO's focus was to use their production process for the pigments and food industries. The process has the most impact on the pigments industry due to its size and potential large cost savings. Initially, other areas were not considered.
8. PRO is considering licensing their technology for emerging technologies such as batteries and solar applications. No specific companies have been contacted at this time, and PRO has not considered any other US based companies.
9. PRO has a technology licensing agreement with Canadian Titanium Limited (Ontario based private company that is owned 50.1% by ARGEX) and ARGEX Titanium Inc. (a titanium dioxide production start-up located in Quebec, Canada) This relationship is outlined in a separate Intellectual Property Management document.
10. PRO can license their process for production for up to 10% of the annual world market for TiO<sub>2</sub> (cap of ~4 to ~5 million tons/yr.)
11. ARGEX has completed it's 2<sup>nd</sup> round of funding to construct a plant that will produce ~90,000 tpa (tons per annum) of high purity TiO<sub>2</sub>.
12. ARGEX has focused on supplying TiO<sub>2</sub> to the paints and coatings market since it is currently the largest market for TiO<sub>2</sub> and demand continues to grow.
13. ARGEX has signed a long-term supply agreement with PPG Industries to initially provide ~50,000 tpa of high purity TiO<sub>2</sub>
14. ARGEX has signed an exclusive long term marketing and supply agreement with HELM US Corp (sub of HELM AG, Germany) for the distribution of TiO<sub>2</sub> in the US and Canada.
15. ARGEX believes that it can produce high purity TiO<sub>2</sub> for a cost of ~\$1,000/ ton in a more environmentally friendly way compared to current processes

16. ARGEX is planning to construct or retrofit several plants globally that will produce ~300,000 tpa to ~400,000 tpa of TiO<sub>2</sub>
17. ARGEX is also planning to license its technology to legacy TiO<sub>2</sub> producers globally

**Critical Unknowns:**

1. What products currently use high purity TiO<sub>2</sub> (*at what levels*) and at what quantities (*Limited data regarding the current demand for high purity TiO<sub>2</sub> by industry/product*)?
2. What are the potential new markets for high purity TiO<sub>2</sub> (*i.e. substitutes*)? (*scientific question*)
3. How do we intend to compete with existing producers of high purity TiO<sub>2</sub>: a) lower production cost, b) lower price, c) higher quality/purity, d) higher quantity?
4. What will make users of high purity TiO<sub>2</sub> purchase from our facility (*what is our differentiator*)?
5. Is it feasible to replace existing high purity TiO<sub>2</sub> producers for certain industries or produce for new demand/end users (*i.e. new markets*)?

**Summary of Market Study:****Supply and Price-**

Ilmenite is a titanium-iron oxide mineral and is the primary source of TiO<sub>2</sub>. Currently, four producers (Rio Tinto, Iluka Resources, Exxaro Resources, and Kenmare Resources) provide ~60% of the global supply of ilmenite.

The price for ilmenite has declined since 2012 and currently sells for ~\$160/ton to ~\$180/ton. This was driven mostly by the collapse of commodity prices which has occurred since their peak in early 2011.

Most ilmenite is mined to produce TiO<sub>2</sub> (~45% to ~50% annually). Most TiO<sub>2</sub> is produced primarily in pigmentary form (~98% of total production) and used for applications that require white opacity and brightness (such as paints & coatings). TiO<sub>2</sub> pigment is characterized by its purity, refractive index, particle size, and surface properties.

About five to seven producers provide ~60% to ~70% of global supply of TiO<sub>2</sub>. Four of these companies are headquartered in the USA (Chemours, Huntsman, Kronos, and Tronox). However, production of TiO<sub>2</sub> in China is growing dramatically and these China based companies (Henan Billions Chemicals being the largest) provide much of the remaining global supply. Major suppliers typically enter into supply agreements with large end users with terms of not more than 6 months.

The price of TiO<sub>2</sub> has averaged \$3,604/ton from 2012 to 2015, hit a low of \$2,646/ton in early 2016, and is projected to average \$3,047/ton from 2017 to 2022. Current prices range between \$3,200 and \$3,400/ton.

The supply side of TiO<sub>2</sub> production is going through a consolidation. Most of the major industry producers were once part of larger conglomerates (i.e. DuPont owned Chemours, Kerr-McGee owned Tronox, etc.). Currently, Tronox is purchasing Cristal (largest foreign producer) to create the largest TiO<sub>2</sub> producer in the world, and Huntsman is planning to spin-off Venator Materials. In addition, Huntsman and Chemours have removed a combined 270,000 tpa of capacity. The result should lead to more price discipline for TiO<sub>2</sub> in the near term.

#### Demand and Price –

The production of TiO<sub>2</sub> is used for paints & coatings, plastics, paper, inks, and a variety of other applications. Application usage for the USA market is listed below:

- a. Paints & Coatings make up ~60% of the USA TiO<sub>2</sub> market, demand to increase ~1.9%/yr. to ~490,000 tpa by 2020. PPG and Sherwin Williams are the largest producers of paint with ~25% of the global market. This market share will increase as PPG is attempting to purchase Akzo Nobel and Sherwin Williams is acquiring Valspar. Other large paint manufacturers include Valspar, Masco Corp, Behr Process Corp, and Akzo Nobel.
- b. Plastics make up ~20% of USA TiO<sub>2</sub> market, demand is to increase <1%/yr. to ~195,000 tpa by 2020. The top five global plastics manufacturers are ExxonMobil, ENI, BASF, Dow Chemical, and SABIC.
- c. Paper makes up ~12% of USA TiO<sub>2</sub> market, demand to remain unchanged at ~77,000 tpa by 2020. The top five global paper producers are International Paper, Nine Dragon, West Rock, UPM and Stora Enso.
- d. Printing Ink make up ~3% of the USA TiO<sub>2</sub> market, demand to be stable. The top five global ink manufacturers are DIC/Sun Chemical, Flint Group, Toyo Ink, Sakata INX, and Siegwark Group.
- e. All other applications of TiO<sub>2</sub> make up ~5% of the USA TiO<sub>2</sub> market at ~24,000 tpa by 2020:
  - i. Food
  - ii. Pharma

- iii. Cosmetics
- iv. Textiles
- v. Electronics
- vi. Ceramics
- vii. Construction materials

Overall demand for TiO<sub>2</sub> in the USA is expected to increase ~1.4%/year from 747,000 tpa in 2015 to 800,000 tpa by 2020. In comparison, China demand for TiO<sub>2</sub> is expected to increase ~5.6%/year through 2020. Continued expansion in building construction activity is expected to drive the USA growth in demand due to its position as a major market for paints and plastics.

The average price of TiO<sub>2</sub> was \$3,604/ton from 2012 to 2105. The average price of TiO<sub>2</sub> is projected to be \$3,047/ton from 2017 to 2020. TiO<sub>2</sub> currently trades at ~\$3,200/ton.

The largest market for TiO<sub>2</sub> is paintings & coatings, but competition is high and ARGEX (new process) has contracted their entire new production on this market segment partnering with PPG.

Plastics and Paper comprise ~32% of the market demand, but expected future demand is stable for plastics and continued decline for paper.

Printing ink comprises ~3% of the market and with expected modest growth. This could be a market opportunity for Minnesota production.

A Minnesota based operation would have to replace current suppliers providing TiO<sub>2</sub> for paint, paper, plastics, and ink applications. This is possible, if the product is provided to the manufacturers at a higher purity level and lower price (i.e. differentiators). The operation could supply a niche market, such as electronics, but quantity demanded would be very small relative to the expected production capacity.

The food & pharma industries comprise ~1% of the market, but overall quantity demanded is low (> 5,000 tpa).

TOHO Titanium Co. LTD (public, Japan) produces high purity TiO<sub>2</sub> for the electronics market (MLCC), demand has been on a steep upward trend since 2008, and projected to continue to increase through 2021 – but overall quantity demanded is small due to the amount needed for each tiny component.

Overall demand for TiO<sub>2</sub> for the applications in the “Other” products category is projected to grow modestly to ~24,000 tpa (i.e. small quantity demanded).

**Production Opportunities:**

1. Produce high purity TiO<sub>2</sub> for the paint/coatings industry but obtain a supply agreement from producers with manufacturing facilities in the area (i.e. Sherwin-Williams/Valspar).
2. Produce high purity TiO<sub>2</sub> for the plastics industry but obtain a supply agreement from producers with manufacturing facilities in the area (i.e. Dow Chemical, PolyOne Corp, SABIC, etc.)
3. Determine what products can use high purity TiO<sub>2</sub> that don't now (substitute an input). Find a specialty market.
4. Determine what products currently use high purity TiO<sub>2</sub> at small quantities, but are projected to increase demand above current overall market levels as the demand for the niche product increases.

**Ilmenite/TiO<sub>2</sub> Supply Chain:**

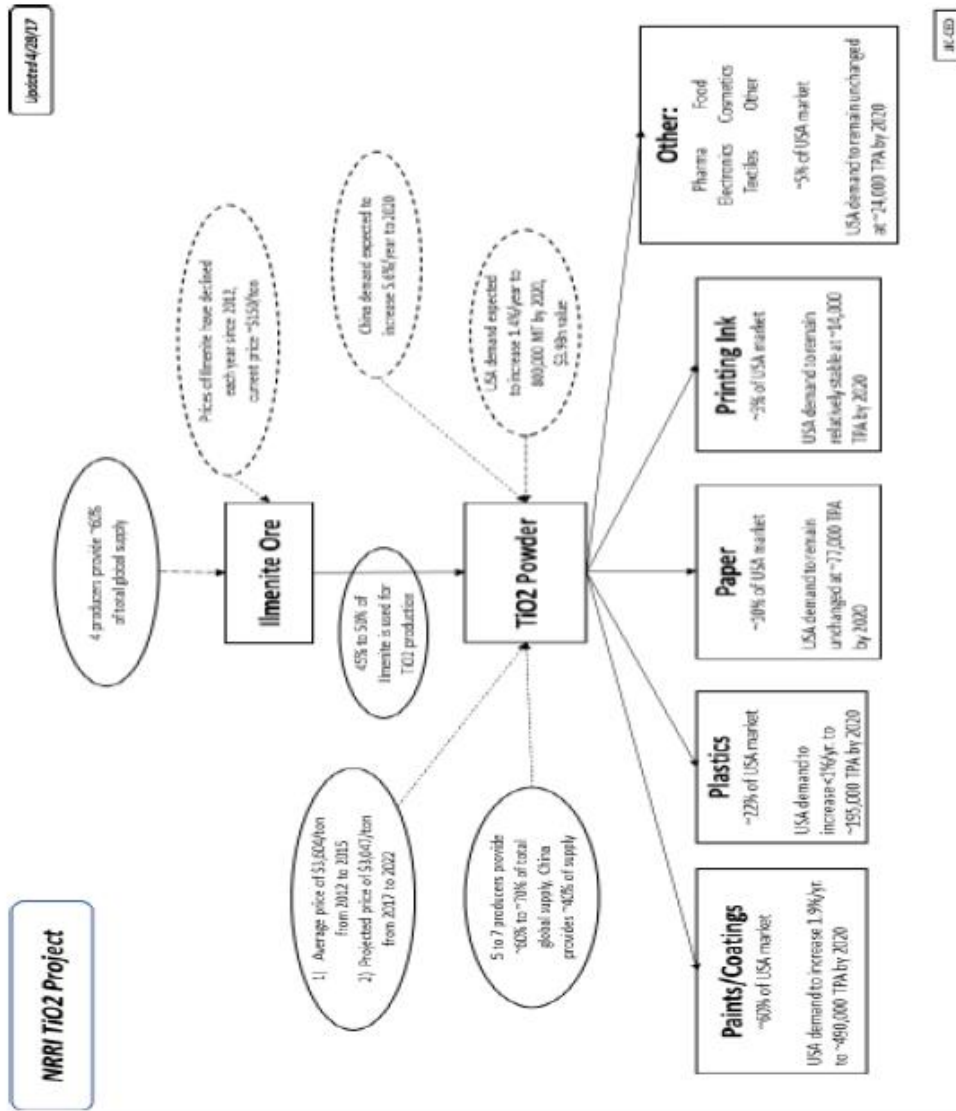

Appendix – research information

### Ilmenite - Supply:

Ilmenite is the titanium-iron oxide mineral with the idealized formula  $\text{FeTiO}_3$ . It is a weakly magnetic black or steel-gray solid. From the commercial perspective, ilmenite is the most important ore of titanium. Ilmenite is the main source of titanium dioxide, which is used in paints, fabrics, plastics, paper, sunscreen, food and cosmetics.

Most ilmenite is mined for titanium dioxide production. In 2011, about 47% of the titanium dioxide produced worldwide were based on this material. Finely ground titanium dioxide is a bright white powder widely used as a base pigment in paint, paper and plastics. Metallic Titanium can be easily derived from it for uses such as aircraft and high-strength steel devices.

North America and Europe together consume about 50% of the world's titanium dioxide production. Demand by India and China is growing rapidly (~5.6% each year) and may eventually surpass Western consumption.

Ilmenite is ultimately converted into pigment grade titanium dioxide via either the sulfate process or the chloride process. Sulfate process plants must utilize low-vanadium ilmenite, as vanadium is a penalty element. Titanium dioxide pigment can also be produced from higher titanium content feedstocks such as upgraded slag, rutile and leucoxene via a chloride acid process. Sulfate and chloride process pigment tends to be used for lower and higher quality applications respectively, users more and more preferring the chloride process. The five largest  $\text{TiO}_2$  pigment processors are DuPont, Cristal Global, Huntsman, Kronos and Tronox, DuPont having pioneered the chloride process in the 1960s and having converted to the use of the chloride process for all its applications. Major paint and coating company end users for pigment grade titanium dioxide include Akzo Nobel, PPG Industries, Sherwin Williams, BASF, Kansai Paints and Valspar. Global  $\text{TiO}_2$  pigment demand for 2010 was 5.3 Mt with annual growth expected to be about 3-4%.

Most ilmenite ore production from Canada, South Africa and Norway is destined for titaniferous slag application. Carbon (anthracite) and energy are added in large electric arc smelting furnaces to convert the ilmenite into molten iron bath and slag rich in titanium dioxide. The iron can be further processed as pig iron, as continuous cast steel billets, or as iron or steel powders. A related chemically process technology is termed the Becher process.

Australia was the world's largest ilmenite ore producer in 2011, with about 1.3 million tons of production, followed by South Africa, Canada, Mozambique, India, China, Vietnam, Ukraine, Norway, Madagascar and United States.

Although most ilmenite is recovered from heavy mineral sands ore deposits, ilmenite can also be recovered from layered intrusive sources or "hard rock" titanium ore sources.

The top four global ilmenite and rutile feedstock producers in 2010 were:

- i. Rio Tinto Group (*public - London, England*)
- ii. Iluka Resources (*public - Perth, Australia*)

- iii. Exxaro Resources (*public – South Africa*)
- iv. Kennmare Resources (*public – London, England*)

Which collectively accounted for more than 60% of world's supplies.

The world's two largest open cast ilmenite mines are:

- The Tellnes mine located in Sokndal, Norway, and run by Titania AS (owned by Kronos Worldwide Inc.) with 0.55 tpa capacity and 57 Mt contained TiO<sub>2</sub> reserves.
- The Rio Tinto Group's Lac Tio mine located near Havre Saint-Pierre, Quebec in Canada with a 3 tpa capacity and 52 Mt reserves.

Major mineral sands based ilmenite mining operations include:

- Richards Bay Minerals in South Africa, majority-owned by the Rio Tinto Group.
- Kennmare Resources' Moma mine in Mozambique.
- Iluka Resources' mining operations in Australia including Murray Basin, Eneabba and Capel.
- The Kerala Minerals & Metals Ltd (KMML), Indian Rare Earths (IRE), VV Mineral mines in India.
- TiZir Ltd.'s Grande Cote mine in Senegal [18]
- QIT Madagascar Minerals mine, majority-owned by the Rio Tinto Group, which began production in 2009 and is expected to produce 0.75 tpa of ilmenite, potentially expanding to two tpa in future phases.

Attractive major potential ilmenite deposits include:

- The Karhujupukka magnetite-ilmenite deposit in Kolari, northern Finland with around 5 Mt reserves and ore containing about 6.2% titanium.
- The Balla Balla magnetite-iron-titanium-vanadium ore deposit in the Pilbara of Western Australia, which contains 456 million tons of cumulate ore horizon grading 45% Fe, 13.7% TiO<sub>2</sub> and 0.64% V<sub>2</sub>O<sub>5</sub>, one of the richest magnetite-ilmenite ore bodies in Australia
- The Coburn, WIM 50, Douglas, Pooncarie mineral sands deposits in Australia.
- The Magpie titano-magnetite (iron-titanium-vanadium-chrome) deposits in eastern Quebec of Canada with about 1 billion tons containing about 43% Fe, 12% TiO<sub>2</sub>, and 0.4% V<sub>2</sub>O<sub>5</sub>, and 2.2% Cr<sub>2</sub>O<sub>3</sub>.

<https://en.wikipedia.org/wiki/Ilmenite>

### **Titanium Dioxide – Industry**

The US market for titanium mineral concentrates is largely served by imports. Consumers of titanium metal are also heavily reliant on foreign sources, while the majority of pigment demand is fulfilled by domestic suppliers. Among the leading suppliers of titanium metal to the US market in 2015 were Chemours, Cristal (Saudi Arabia), and Precision Castparts. The titanium concentrates and TiO<sub>2</sub> pigment industries are concentrated. In 2015, some 40% of the global supply of titanium concentrates was produced by four companies, while five producers – all of which maintain production facilities in the US – accounted for about 60% of global TiO<sub>2</sub> capacity in 2015.

TiO<sub>2</sub> is a commodity pigment; the industry is characterized by high barriers to entry, few producers, and a large number of consumers. On the consumer side, senior managers make buying decisions due to the high cost of TiO<sub>2</sub> pigment. DuPont spun off its pigment operations into Chemours in July 2015 due to the capital-intensive nature of commodity businesses and the volatile pricing of TiO<sub>2</sub> pigment. It should be noted that the other major participants are also pure-play suppliers (e.g., Cristal, Kronos, and Tronox).

#### **Titanium Dioxide -**

Titanium is the 9th most abundant element in the world and Titanium Dioxide (TiO<sub>2</sub>) is the oxide of the metal, which occurs naturally in several kinds of rock and mineral sands.

Pure TiO<sub>2</sub> is a fine, white powder and is the brightest, whitest pigment available. Highly refractive, ultraviolet absorbing, non-toxic and inert, TiO<sub>2</sub> has been used for many years (over 90) in a vast range of industrial applications and consumer goods to impart whiteness and opacity to paints, printing inks, plastics, textiles, ceramics, construction materials, cosmetics, food, pharmaceuticals, etc.

TiO<sub>2</sub> is produced primarily in the pigmentary form (over 98% of total production) making use of its excellent light-scattering properties in the wide range of applications that require white opacity and brightness.

TiO<sub>2</sub> is also produced as an ultrafine (nanomaterial) product when different properties such as transparency and maximum UV light absorption are required, such as in cosmetic sunscreens. Ultrafine TiO<sub>2</sub> products are also used in a range of environmental applications such as catalysts supports in the automotive industry to remove harmful exhaust gas emissions, and in power stations to remove nitrous oxides (NO<sub>x</sub>). Approximately 1-2% of the total production of TiO<sub>2</sub> is in this ultrafine form.

<http://www.tdma.info/about-tio2>

#### **Ultrafine Titanium Dioxide**

Pigment grade TiO<sub>2</sub> is manufactured to optimize the scattering of visible light which requires primary particles in the size range of approximately half the wave length of the visible light, whereas ultrafine TiO<sub>2</sub> is engineered to have primary particles in the nanoparticle size range that is below 100 nm. Accordingly, the scattering of visible light is significantly reduced and the

TiO<sub>2</sub> nanoparticles are transparent. Transparency and other properties related to this size provide different beneficial properties from those seen for the pigmentary product.

Ultrafine TiO<sub>2</sub> has been used since the 1950s to reduce the environmental emissions of Nitrogen Oxides. It is used in "Selective Catalytic Reduction (SCR)" systems that convert the nitrogen oxides into harmless nitrogen and water. Commercial SCR systems are typically installed in large industrial boilers, combustion plants and stationary or automotive diesel engines.

The transparency and UV absorbance of ultrafine TiO<sub>2</sub> allows for its' effective use as a protective ingredient in sunscreens. It contributes to high sun protection factors (SPF) and has been used for many years to provide protection from the harmful ultraviolet radiation from the sun.

Another application uses the photocatalytic properties of ultrafine TiO<sub>2</sub> to provide self-cleaning surfaces e.g. on glass and cement.

Although ultrafine TiO<sub>2</sub> is comprised of primary particles in the nano size range, an inherent property of ultrafine TiO<sub>2</sub> is that the primary particles are strongly bound or fused together by chemical bonds to form aggregates. These aggregates readily agglomerate to form particles in the micrometer size range.

<http://www.tdma.info/ultrafine-tio2>

#### **Titanium Dioxide High Purity Powder:**

Titanium Oxide Micro Powder (TiO<sub>2</sub>, high purity)  
APS: 1500nm  
Purity: 99.9+%  
Color: white  
SSA: ~5-8m<sup>2</sup>/g  
Melting Point: 3,349°F (1,843°C)  
Boiling Point: 5,382°F (2,972°C)  
Molar Mass: 79.866 g/mol

#### **Application:**

1. UV-resistant material, chemical fiber, plastics, printing ink, paints/coatings
2. Photo catalyst, self-cleaning glass, self-cleaning ceramics, antibacterial material, air purification, sewage treatment, chemical industry
3. Cosmetics, sunscreen cream, natural white moisture protection cream, beauty and whitening cream, morning and night cream, moistening refresher, vanishing cream, skin protecting cream, face washing milk, skin milk, powder make-up;
4. Coating, printing ink, plastics, foods packing material

5. Coating for paper-making industry: used for improving the impressionability and opacity of the paper and used for producing titanium, ferrotitanium alloy, carbide alloy etc. in the metallurgical industry
6. Astronautics industry

<http://www.us-nano.com/inc/sdetail/1796>

### **Nanoparticle Titanium Dioxide Market – High Purity TiO<sub>2</sub>??**

#### **Global Nanoparticle Titanium Dioxide (TiO<sub>2</sub>) Market: Overview**

The global nanoparticle titanium dioxide industry is a niche market and the demand for these materials is expected to gain a strong momentum in the coming years. The demand will especially arise from industries such as plastics, paints and pigments, printing inks, catalysts, paper, cosmetics, and glass. The demand for nanoparticle titanium dioxide is estimated to be more from Asia Pacific. A surge in the use of cosmetics is one of the drivers of the global TiO<sub>2</sub> market. The growing use of plastic for the manufacturing of toys and various other objects will help drive the demand for nanoparticle titanium dioxide.

#### **Global Nanoparticle Titanium Dioxide (TiO<sub>2</sub>) Market: Trends and Opportunities**

The trend of light-weight vehicles is expected to benefit the global nanoparticle titanium dioxide market as the demand for polycarbonate is expected to increase in place of glass or metal. Titanium dioxide is extensively used to coat polycarbonate and thus, will drive the market's growth in the coming years. A surge in construction activities across countries will also bolster the demand for titanium dioxide. Growth in construction activities will drive the demand for paints and coatings, and this in turn will benefit the market for nanoparticle titanium dioxide.

However, the global Nanoparticle TiO<sub>2</sub> industry is expected to be restrained by stringent regulations by various regulatory bodies with regards to carcinogenic properties. This is expected to hamper the growth of the market.

#### **Global Nanoparticle Titanium Dioxide (TiO<sub>2</sub>) Market: Region-wise Outlook**

The global nanoparticle titanium dioxide market is segmented on the basis of geography into Asia Pacific, Europe, North America, and the Rest of the World. It is anticipated that the demand will be high from Asia Pacific owing to an increased support from government for nanotechnology as well as the presence of a large number of companies that develop products and processes based on nanoparticles. China is expected to be a key contributor to the market. In addition to this, various other emerging nations are expected to witness a high growth in the TiO<sub>2</sub> industry within the next few years. Moreover, high demand for cosmetics from countries such as the U.S., the U.K., France, Italy, Brazil, and Germany is expected over the coming years, which will drive the demand for TiO<sub>2</sub> in these areas. A higher spending power and increasing number of beauty conscious people in these countries will also help drive the market.

<http://www.transparencymarketresearch.com/nanoparticle-titanium-dioxide-tio2-market.html>

### Titanium Dioxide CEH Report – 2015

Titanium dioxide (TiO<sub>2</sub>) is the standard white pigment used principally in paints, paper, and plastics. It is the most important pigment in the world, accounting for approximately 70% of total volume. Titanium dioxide is made by processing a variety of titanium-containing minerals such as ilmenite and rutile. Rutile has a titanium dioxide content of 94-96%, making it highly desirable as a feedstock. Ilmenite is much more plentiful, but has a titanium dioxide content of 50–60%, so it is usually upgraded, or beneficiated, to a higher titanium dioxide content.

Seven major world titanium dioxide producers account for over half of world capacity; the remainder includes about 75 Chinese producers with a 44% capacity share, and other smaller regional producers with a 5% share.

The year 2014 was characterized by poor market demand for titanium dioxide, which resulted in further consolidation among the top producers. Other factors that came into play were that China became a major producer, increasing supply while demand declined with a slowdown in Chinese construction.

The major consuming industries for TiO<sub>2</sub> pigments are paints and surface coatings, plastics, and paper and paperboard. Consumption tends to parallel general economic trends for these end-use applications. Ultrafine grades of titanium dioxide (particle sizes between 1 and 150 nanometers) are used as catalysts, UV blockers, color pigment precursors, and electro ceramics. This area is growing, but is relatively small and will not affect the overall market significantly.

North American consumption has dropped noticeably during the last decade, mainly as a result

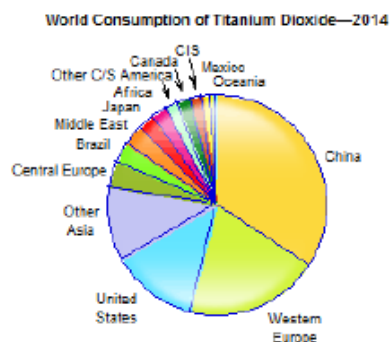

of the decrease in coatings consumption caused by the poor construction and manufacturing markets. Paint and coatings remains the largest outlet, accounting for almost 60% of consumption. Western European and Japanese consumption remains stagnant. The real driver to growth is China, where the coatings and plastics industries continue to expand at high rates. The potential remains high. Per capita consumption of TiO<sub>2</sub> in China is about 1.1 kilograms per year, compared with 2.7 kilograms for Western Europe and the United States.

Between 2011 and 2014, China increased its share of total world titanium dioxide consumption from 29% to 34%, and is forecast to further increase its share to 37% by 2019. An average annual growth rate of about 5.6% is forecast for Chinese consumption over the next five years.

Demand for nanoparticle titanium dioxide for use in high-efficiency photovoltaic installations is expected to increase demand for titanium dioxide during 2014–19. Titanium dioxide nanoparticles are used as a semiconductor in this technology, making it more economical and efficient.

<https://www.ihc.com/products/titanium-dioxide-chemical-economics-handbook.html>

### Prices of Titanium Dioxide

The price of TiO<sub>2</sub> has averaged \$3,604/ton from 2012 to 2015, hit a low of \$2,646/ton in early 2016, and is projected to average \$3,047/ton from 2017 to 2022.

As per ARGEX Titanium Inc. TiO<sub>2</sub> currently trades at approximately \$3,200 to \$3,400/ton.

<http://marketrealist.com/2016/12/tronox-increases-prices-across-titanium-dioxide-grades/>

### Supply of Titanium Dioxide -

The following chart indicates the estimate of worldwide production capacity of TiO<sub>2</sub> in 2015:

a) Chemours ( <i>formerly Performance Chemicals segment of DuPont</i> )	17%
b) Huntsman ( <i>Pigment and Additives segment to be Venator Materials Corp</i> )	12%
c) Cristal Global	12%
d) Kronos	8%
e) Tronox	7%
f) Others ( <i>including Henan Billions and Pangang Group – China</i> )	44%

Top 5 global producers of TiO<sub>2</sub> had ~56% of total production capacity in 2015.

#### 1. DuPont (Wilmington, DE)

E. I. du Pont de Nemours and Company, commonly referred to as DuPont, is an American conglomerate that was founded in July 1802 as a gunpowder mill by French-American chemist and industrialist Éleuthère Irénée du Pont. DuPont is a science company dedicated to solving challenging global problems, while creating measurable and meaningful value for its customers, employees and shareholders. Their dynamic portfolio of products, materials and services meets the ever-changing market needs of diverse industries in more than 90 countries.

On October 24, 2013, DuPont announced its intention to separate its Performance Chemicals segment, which includes its titanium technologies, fluoroproducts, and chemical solutions businesses, from the other businesses of DuPont. This separation took place on

July 1, 2015, and was effected by a distribution of Chemours common stock on a pro rata basis to DuPont stockholders. This created a new, independent, publicly traded company named The Chemours Company (Chemours). Chemours is a leading global provider of performance chemicals through three reporting segments: Titanium Technologies, Fluoroproducts, and Chemical Solutions. The *Titanium Technologies* segment is the leading global producer of titanium dioxide (TiO<sub>2</sub>), a premium white pigment used to deliver opacity.

❖ **The Chemours Company (Wilmington, DE) (Public)**

- The Chemours Company ranks first among titanium dioxide manufacturers in production capacity, product quality, and customer service
- They operate a titanium mine in Starke, Florida that provides them access to high quality ilmenite ore feedstock
- They operate four TiO<sub>2</sub> production facilities: two in the U.S., one in Mexico and one in Taiwan
- *They sell over 20 different grades of TiO<sub>2</sub>*
- In 2016, they generated \$2,364 million in Titanium Dioxide sales down from \$2,392 million in 2015
- In total, they have a TiO<sub>2</sub> capacity of 1.25 million metric tons per year
- They sell their TiO<sub>2</sub> products under the Ti-Pure™ brand name to over 800 customers globally
- Their customer base includes a diverse set of companies, many of which are leaders in their respective industries. Their sales are not materially dependent on any single customer. As of December 31, 2016, no one individual customer balance represented more than five percent of Chemours' total outstanding receivables balance and no one individual customer represented more than ten percent of their sales.

[https://www.chemours.com/Titanium\\_Technologies/de\\_US/tech\\_info/literature/Coatings/CO\\_B\\_H\\_65969\\_Coatings\\_Brochure.pdf](https://www.chemours.com/Titanium_Technologies/de_US/tech_info/literature/Coatings/CO_B_H_65969_Coatings_Brochure.pdf)

[https://s2.q4cdn.com/107142371/files/doc\\_financials/2016/Chemours-Company-Annual-Report.pdf](https://s2.q4cdn.com/107142371/files/doc_financials/2016/Chemours-Company-Annual-Report.pdf)

2. **Huntsman Corporation (The Woodlands, TX) (Public)**

Huntsman is a global manufacturer and marketer of differentiated chemicals. The operating companies manufacture products for a variety of global industries, including chemicals, plastics, automotive, aviation, textiles, footwear, paints and coatings, construction, technology, agriculture, health care, detergent, personal care, furniture, appliances and packaging.

Subject to market conditions, Huntsman Corporation intends to spin-off its Pigment and Additives business during Q2 2017, which will be known as Venator Materials Corporation (Venator). Following its spin-off from Huntsman, Venator will be a leading global manufacturer and marketer of chemical products that improve the quality of life of consumers everywhere.

They operate 27 manufacturing facilities, have more than 4,500 associates and generated revenues of \$2.1 billion in 2016. Their products include a broad range of pigments and additives that add color and vibrancy, protect and extend product life, and reduce energy consumption. Our key product lines include titanium dioxide pigments, color pigments, functional additives, timber treatment and water treatment products.

<http://www.venatorcorp.com/>

❖ **Huntsman Pigments & Additives (Augusta, GA)**

Huntsman Pigments and Additives is a strong, specialized global business with a high value portfolio of innovative products. They are passionate about creating value for their customers to help meet the demands of an ever-changing world.

They are one of the most diversified global suppliers of pigments and additives. Since the acquisition of Rockwood's performance additives and titanium dioxide businesses in 2014, they now offer a broad range of specialty titanium dioxide pigments, color pigments, functional additives, and timber and water treatment chemicals.

Their pigments and additives add performance and color to thousands of everyday items from paints, inks, plastics and concrete to cosmetics, pharmaceuticals and food.

- Their Pigments & Additives division earned \$2,139 million in revenue in 2016 and \$130 million adjusted EBITDA in 2016

[https://materials.proxyvote.com/Approved/447011/20170310/AR\\_312527/pubData/source/Huntsman%202016%20AR%20for%20Web%20posting%20Bookmarked.pdf](https://materials.proxyvote.com/Approved/447011/20170310/AR_312527/pubData/source/Huntsman%202016%20AR%20for%20Web%20posting%20Bookmarked.pdf)

3. **Cristal Global (Jeddah, Saudi Arabia) (Private)**

Cristal and its nearly 4,000 employees on five continents is the 2<sup>nd</sup> leading manufacturer of titanium dioxide products, and the world's largest manufacturer of ultrafine titanium dioxide.

- Cristal Global directs the operation of eight manufacturing plants on five continents, with locations in Ashtabula, Ohio; Baltimore, Maryland; Salvador, Bahia; Stalling borough, UK; Thann, France; Yanbu, Saudi Arabia; Bunbury, Australia; and a mine site in Paraiba, Brazil.
- \$1.75 billion total sales in 2015

<http://www.titaniumexposed.com/titanium-suppliers.html>

[http://www.cristal.com/Corporate%20Fact%20Sheet/Corp\\_Sheet\\_EN.pdf](http://www.cristal.com/Corporate%20Fact%20Sheet/Corp_Sheet_EN.pdf)

4. **KRONOS Worldwide, Inc. (Dallas, TX) (Public)**

Since 1916, KRONOS Worldwide, Inc. has been producing titanium dioxide pigments (TiO<sub>2</sub>), the world's primary pigment for providing whiteness, brightness and opacity. KRONOS operates TiO<sub>2</sub> production plants around the world in five countries on two continents. They also operate their own ilmenite mine – a key raw material in the TiO<sub>2</sub>

pigment production process. Their international distribution network, with a production capacity of over 555,000 tons, stretches across oceans to wherever you need product.

- KRONOS is a global leader in the manufacturing and sale of titanium dioxide with seven manufacturing sites in North America and Europe and sales offices throughout the world
- They produced 528,000 metric tons of TiO<sub>2</sub> in 2015, up from 511,000 metric tons in 2014
- KRONOS had net sales of \$1,348.8 million in 2015
- They sell to a diverse customer base with only one customer representing 10% or more of their sales in 2015 (Behr Process Corporation – 10%)

KRONOS Sales Volumes % by geographic areas:

Europe	52%
North America	29%
Asia Pacific	8%
Rest of world	11%

KRONOS Sales Volumes % by end-products:

Paints/Coatings	55% - 60%
Plastics	31%
Other	9%
Paper	5%

<http://www.titaniumexposed.com/titanium-suppliers.html>  
<file:///N:/SBE/Ced/common/CED%20-%20Client%20Files%20L%20-%20NRRI-Titanium%20Recovery%20Project/KRO-ann-rprt-15.pdf>

**5. Tronox Inc. (Stamford, CT) (Public)**

Tronox Limited is a global leader in the mining, production and marketing of inorganic minerals and chemicals. The company operates two vertically integrated businesses: Titanium dioxide (TiO<sub>2</sub>) and Alkali Chemicals.

The TiO<sub>2</sub> business mines and processes titanium ore, zircon and other minerals, and manufactures TiO<sub>2</sub> pigments that add brightness and durability to paints, plastics, paper, and other everyday products. The business operates mines and mineral processing plants in South Africa and Australia, and pigment manufacturing plants in the United States, the Netherlands, and Australia.

Tronox's mineral sands operations consist of two product streams – titanium feedstock, which includes ilmenite, natural rutile, titanium slag and synthetic rutile; and zircon, which is contained in the mineral sands extracted to capture natural titanium feedstock. Tronox operates three separate mining operations: KZN Sands and Namakwa Sands located in

South Africa and Perth in Western Australia, which have a combined production capacity of 753,000 metric tons of titanium feedstock and 265,000 metric tons of zircon.

Tronox markets a range of titanium dioxide pigment grades, and our talented team of scientists' works to enhance the performance of products in our customers' current and future applications.

Tronox is one of only five major producers of TiO<sub>2</sub> with proprietary chloride process technology. The chloride process, which accounts for 100 percent of Tronox's pigment production gross capacity, produces pigment grades with a brighter appearance that is often preferred by manufacturers of coatings and plastics.

Tronox is among the lowest-cost producers of the product globally. This is of particular importance as it positions Tronox to be competitive through all facets of the TiO<sub>2</sub> cycle. In addition, our company's three TiO<sub>2</sub> production facilities are strategically positioned in key geographies to reach key markets worldwide.

- Tronox TiO<sub>2</sub>: \$215 million 2015 EBITDA
- About 1,500,000 metric tons of TiO<sub>2</sub> produced in 2015
- Tronox operates three separate mine & beneficiation facilities, two in South Africa & one in Australia
- ANSAC accounted for 10% of their consolidated sales

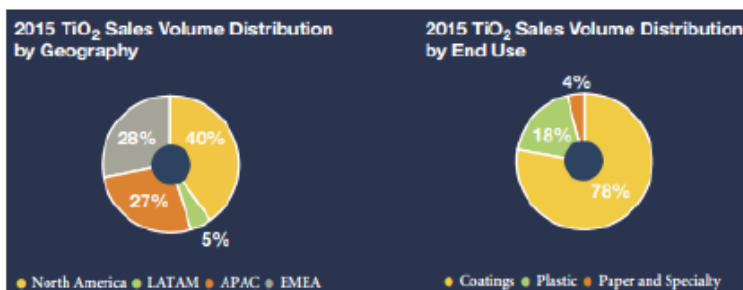

<http://www.titaniumexposed.com/titanium-suppliers.html>

[http://files.shareholder.com/downloads/TRX/4081503670x0x885104/6E176A7B-EA2C-4730-AD46-9B5385EC20BD/TRONOX\\_2015.pdf](http://files.shareholder.com/downloads/TRX/4081503670x0x885104/6E176A7B-EA2C-4730-AD46-9B5385EC20BD/TRONOX_2015.pdf)

#### 6. Henan Billions Chemicals (China) (Public)

Henan Billions Chemicals Co., Ltd. with \$3 billion in total assets is a large inorganic fine chemical enterprise concentrated on the development and manufacture of titanium and zirconium fine powder materials. The company is publicly traded with stock code 002601 listed in Shenzhen Stock Exchange. The main products of Henan Billions Chemicals Co., Ltd. are titanium dioxide, zirconium and sulfate products whose scales are the top in China. Their products sell well all over China and also export to dozens of countries and regions such as America, Japan, Brazil and etc.

- Henan Billions Chemicals became China's largest manufacturer of titanium dioxide after acquiring Sichuan Lomon, with the annual capacity of 610,000 tons (including 60,000 tons of titanium dioxide produced by chlorination process).
- \$2,660 million in total company revenue in 2015

<http://www.premewire.com/news-releases/global-and-china-titanium-dioxide-industry-report-2016-2020-300369424.html>

<http://financials.morningstar.com/income-statement/is.html?t=002601&region=chn>

7. **Pangang Group Vanadium Titanium & Resources (Panzhuhua, China) (Public)**  
Panzhuhua Iron and Steel Research Institute (PISI), formerly known as Anshan Iron and Steel Research Institute and Southwest Iron and Steel Research Institute, was first incorporated in 1964 in Anshan in the northeast China. In 1980's it was merged into Pangang and affiliated to both Pangang (Group) Corp. and Panzhuhua Iron and Steel Co. Ltd.

Currently there are a number of operating sections, including Chengdu Branch, Metallurgical Research, Material Development, Vanadium and Environmental Technology Development, Titanium Development, Testing and Inspection, Sci & Tech Information, Trial Plant, New Material Pilot Base and Sci. & Tech Industry.

- Pangang Group Vanadium Titanium & Resources produced 85,000 tons and sold 80,000 tons of titanium dioxide in 2015, with a sales-output rate of 93.8%. It invested RMB110 million in building a 15kt/a chlorination process titanium dioxide oxidation test equipment project in December 2015, and the project is planned to be put into trial operation at the end of December 2016.

<http://www.panyan.com/>

<http://www.premewire.com/news-releases/global-and-china-titanium-dioxide-industry-report-2016-2020-300369424.html>

## TiO<sub>2</sub> Supply –

*Titanium Dioxide Manufacturers Association (TDMA) - <http://www.tdma.info/>*

The Titanium Dioxide Manufacturers Association - TDMA is a sector group of Cefic (the European Chemical Industry Council) and it represents the major producers of titanium dioxide (TiO<sub>2</sub>) and acts as their responsible voice in Europe since 1974. TDMA is a non-profit organization and it has no commercial role.

### Members:

- [Cinkama Celje d.d.](#)
- [Cristal](#)
- [Evonik Resource Efficiency GmbH](#)
- [Grupa Azoty Zaklady Chemiczne "Police" S.A.](#)

- [Huntsman Pigments](#)
- [KRONOS](#)
- [Precheza AS](#)
- [Tronox Pigments \(Holland\) BV](#)

**Associate Members:**

- [The Chemours Company](#)
- [Tayca](#)

**Additional Producers:**

- [DuPont](#)
- [Shandong Doguide Group Co. Ltd.](#)
- [Henan Billions Chemicals Co. Ltd.](#)
- [CNNC Hua Yuan Titanium Dioxide Co.](#)
- [Jilin Gpro](#)
- [AnHui Annada](#)
- [Sichuan Lomon](#)
- [Pangang Group Research Institute Co. Ltd.](#)
- [Yunnan Dahutong](#)
- [Ningbo Xinfu](#)
- [Jiangsu Taibai](#)
- [Bluestar New Chemical Materials](#)
- [Toho Titanium](#)
- [Rio Tinto](#)

**1. Demand for Titanium Dioxide (Products) –**

**Products That Contain Titanium Dioxide - list**

- **Paints and coatings**
  - Paint is the leading application for TiO<sub>2</sub> pigment by a wide margin
  - Architectural paints
  - Industrial coatings
  - Motor vehicle coatings
  - Can coatings
- **Food**
  - Food colorants
  - Candies, sweets & chewing gum have been found to contain the highest levels of titanium dioxide
  - White powdered doughnuts, candies and gums with hard shells, products with white icing and even bread, mayonnaise, yogurt and other dairy products may contain titanium dioxide
  - Condiments: mayonnaise, mustard, horseradish cream, and vinegar
  - Nut spreads such as almond and peanut butter

- Confectionery sugar
- Desserts such as custard, tapioca pudding, sherbet, and sorbet
- Sausages
- Energy drinks labeled as "sport," "energy," or "electrolyte" beverages with a water base
- Cottage, cream, and processed cheeses
- Processed deli meats
- Canned fish products
- Dairy drinks including chocolate milk, eggnog, kefir, or whey-based drinks
- Prepared foods such as potato and macaroni salad, and foods containing battered fish or poultry
- Processed snacks such as Twinkies and powdered donuts
- **Pharmaceuticals**
  - Gelatin capsules
  - Tablet coatings
  - Syrups
- **Personal Care Products**
  - Toothpastes & sunscreen
  - Lipsticks
  - Creams
  - Ointments
  - Powders
  - To a lesser extent, shampoos, deodorants, and shaving creams
- **Paper and paperboard**
- **Plastics and rubber**
- **Lithium Batteries**
- **Ceramics and glass**
- **Coated fabrics and textiles**
- **Printing and packaging ink**
  - Gravure inks
  - Flexographic inks, glossy
  - Flexographic inks, matt
  - Screen-printing inks
- **Roofing materials**
- **Floor coverings**

<http://articles.mercola.com/sites/articles/archive/2016/01/20/titanium-dioxide-nanoparticles-health-risks.aspx>

<http://theheartysoul.com/foods-with-titanium-dioxide/>

<https://www.drugs.com/inactive/titanium-dioxide-70.html>

### ***Demand and forecast***

US demand for TiO<sub>2</sub> pigment is forecast to total 800,000 metric tons in 2020, representing annual gains of 1.4% from 747,000 metric tons in 2015. Continued expansion in building construction activity will provide the primary impetus for growth, due to its position as a major market for paint and plastic. Increases in various manufacturing sectors, including transportation equipment, will also support demand for paint and plastic – and hence domestic production – further boosting pigment consumption.

TiO<sub>2</sub> is one of the whitest pigments available and is desired for its capacity to impart brightness, opacity, and superior gloss. Despite the relatively high price of TiO<sub>2</sub>, it is nevertheless the most widely used white pigment. Apart from its exceptional whiteness, users specify TiO<sub>2</sub> as opposed to other white pigments because of functional properties such as dispersion, resistance to chemicals and ultraviolet radiation, as well as its thermal stability and durability. In 2015, paint manufacturers were the largest consumers of TiO<sub>2</sub> pigment in the US, followed by plastic and paper producers.

In value terms, US demand for TiO<sub>2</sub> pigment is forecast to total \$3.9 billion in 2020, representing annual gains of 4.8% from \$3.1 billion in 2015. Volume increases coupled with price growth will drive value gains. While prices of titanium mineral feedstock have largely declined since peaking in 2012, producers including The Chemours Company (Chemours), Kronos Worldwide (Kronos), Huntsman Corporation, and Tronox announced price increases for their pigment in January of 2016 due to expected increases in demand.

Building construction is the most important driver of demand for TiO<sub>2</sub> pigment, as 85% of 2015 consumption in the US was attributable to paint and plastic production. Over the 2005-2015 decade, the fastest growth in pigment demand occurred in 2013, as US building construction activity also experienced one of the fastest gains of the decade that year. Production of transportation equipment also significantly impacts demand, as items such as motor vehicles, ships, and aircraft use considerable volumes of paint and plastic. Sales suffered in the later part of the decade due to the rising use of extender pigments and substitutes.

### ***Products:***

#### ***Paints:***

Sales of TiO<sub>2</sub> pigment to paint producers are projected to expand 1.9% per year to 490,000 metric tons in 2020, remaining the leading segment. US paint, coatings, and adhesives shipments are projected to expand 2.7% annually in real terms from 2015 to 2020, as US building construction activity continues to see healthy growth.

- Major global producers of paints:
  1. PPG Industries (*public - Pittsburgh, PA*)
  2. Sherwin-Williams (*public - Cleveland, Ohio*)
  3. Valspar (*public - Minneapolis, MN - to be acquired by Sherwin-Williams*)
  4. Masco Corp. (*public - Taylor, MI*)
  5. Behr Process Corp. (*private - Santa An, CA – owned by Masco Corp*)
  6. Akzo Nobel (*public - Amsterdam, Netherlands – bid by PPG to buy company*)
  7. Axalta Coating Systems (*public – Philadelphia, PA*)
  8. Kansai Paints, LTD (*public - Osaka, Japan*)
  9. BASF SE (*public – Ludwigshafen, Germany*)

US paint, coatings, and adhesives shipments are projected to expand 2.7% annually in real terms from 2015 to 2020, as US building construction activity continues to see healthy growth. Furthermore, advances in motor vehicle output will support sales of automotive coatings containing TiO<sub>2</sub>, while increasing shipments of other durable goods – such as machinery and marine equipment – will drive sales of industrial coatings. However, initiatives by manufacturers of such coatings to reduce TiO<sub>2</sub> consumption will limit stronger gains, though rising capacity in China is expected to help moderate prices and prevent further use of extenders or substitutes.

Paint is the leading application for TiO<sub>2</sub> pigment by a wide margin. Paint consists of binders and pigments, as well as additives such as drying oils dissolved in a solvent (e.g., water). TiO<sub>2</sub> provides opacity, which is beneficial for both colored paints and whites. According to The Sherwin-Williams Company, a leading US paint producer, premium paints typically employ pigments with superior performance properties, such as TiO<sub>2</sub>. Paints of lower quality, the company states, employ a smaller amount of TiO<sub>2</sub> by using lower-cost extenders such as calcium carbonate, kaolin, and talc. However, durability and other performance properties suffer with the use of substitutes or extenders.

TiO<sub>2</sub> pigment is utilized in all of the three major paint markets:

- Architectural paints
- Industrial coatings
- Motor vehicle coatings

### **Paint Manufacturers**

#### Valspar

North America Manufacturing Locations:

- Birmingham, AL
- Garland, TX
- Rochester, PA
- Monterrey, Mexico

#### Sherwin Williams

North America Manufacturing Locations:

- California

- Colorado
- Florida
- Georgia
- Illinois
- Indiana
- Kansas
- Kentucky
- Maryland
- Michigan
- Nevada
- North Carolina
- Ohio
- Pennsylvania
- Tennessee
- Texas
- Canada
  - British Columbia
  - Ontario

#### Masco Corp. Manufacturing Locations

- Behr/Kilz
  - Algona, WA
  - Allentown, PA
  - Imperial, MO
  - McDonough, GA
  - Roanoke, TX
  - Santa Ana, C

#### ***Plastics:***

Consumption of TiO<sub>2</sub> pigment in plastic production is expected to rise less than 1.0% annually to 195,000 metric tons in 2020. In value terms, US demand for titanium metal is forecast to total \$370 million in 2020, representing annual gains of 4.3% from \$300 million in 2015.

The Automotive Coatings Manufacturing industry's performance trended higher over the five years to 2016. During the economic recovery, consumers released pent-up demand for nonessential vehicle alterations and new vehicle purchases in light of rising disposable income, bolstering demand for automotive coatings. To this end, industry revenue rose at an annualized rate of 3.9% to \$7.9 billion over the five-year period, lifted by an estimated 2.3% jump in 2016.

Several new styles of automobile coatings, including those with ultraviolet light-cured finishes and that incorporate nanotechnology, have supported industry demand. Water-based coatings are the future of automotive coating technology and are expected to boost demand for coating

customization, given their ease of use and lower potential cost once the technology is widely adopted. All of these factors will bode well for automotive coatings manufacturers. Industry operators are expected to experience growing demand for their products over the next five years, prompted by an expanding economy. Industry revenue is expected to grow an annualized 2.1% to \$8.7 billion in the five years to 2021.

Gains for pigment demand in plastic production are attributable to the advances expected for building construction activity, which will generate demand growth for polyvinyl chloride (PVC) and engineering plastics used in pipe and other products. Increases in non-building construction, as well as in various manufacturing sectors – including appliances, motor vehicles, and packaging – will also support demand for PVC and engineering plastics.

TiO<sub>2</sub> pigment is utilized in engineering plastics, PVC, and master batch formulations. Engineering plastics are designed to exhibit certain mechanical, chemical, and thermal properties and are typically used in construction and machinery applications. Examples of engineering plastics include acrylonitrile butadiene styrene (ABS), polyamide (or nylon), and polybutylene. In PVC resins, the pigment is found in flexible, calendared, and rigid formulations. A master batch is a concentrate added to a base of plastic resin to impart color or other properties in a cost-effective manner, and is one of the highest volume uses of the pigment in plastics. Reasons for including TiO<sub>2</sub> in plastic resin formulations include improved chemical stability, durability, opacity, weather ability, and whiteness. Important markets for plastics loaded with TiO<sub>2</sub> include appliances, building TiO<sub>2</sub> products, motor vehicles, and packaging.

### **Top Plastic Manufacturers**

#### Dow Chemical

United States Locations:

*\*didn't distinguish if it was manufacturing plant or other.*

- Alabama
- Arkansas
- California
- Connecticut
- Delaware
- Georgia
- Illinois
- Indiana
- Kentucky
- Louisiana
- Massachusetts
- Michigan
- Minnesota
- Missouri
- New Jersey
- New York
- North Carolina

- Ohio
- Pennsylvania
- Tennessee
- Texas
- Virginia
- Washington
- West Virginia

PolyOne Corp.

United States Manufacturing Locations:

- Alabama – 1 manufacturing plant
- Arizona – 2 manufacturing plants
- California – 2 manufacturing plants
- Connecticut – 3 manufacturing plants
- Georgia – 2 manufacturing plants
- Iowa – 1 manufacturing plant
- Illinois – 2 manufacturing plants
- Indiana – 2 manufacturing plants
- Kansas – 1 manufacturing plant
- Kentucky – 1 manufacturing plant
- Maryland – 1 manufacturing plant
- Missouri – 4 manufacturing plants
- New Jersey – 2 manufacturing plants
- New York – 1 manufacturing plants
- Ohio – 9 manufacturing plants
- Oregon – 1 manufacturing plant
- Pennsylvania – 2 manufacturing plants
- Tennessee – 3 manufacturing plants
- Texas – 3 manufacturing plants
- Wisconsin – 4 manufacturing plants

Canada Manufacturing Locations:

- Ontario – 1 manufacturing plant
- Quebec City – 1 manufacturing plant

SABIC Innovative Plastics

*\*Acquired GE Plastics in 2007*

United States Manufacturing Locations:

- Alabama
- Illinois
- Indiana

- Mississippi
- New York

**Paper:**

Demand for TiO2 pigment in paper production is forecast to remain unchanged, at 77,000 metric tons in 2020. The tepid growth expected for US paper and paperboard production, at a 1.0% annual rate from 2015 to 2020, is projected to limit prospects for TiO2 sales in this segment. Nevertheless, the slow growth expected for paper production will represent a significant improvement over the declines of the historical period. For example, production of paper laminate products is forecast to rise as building construction activity picks up. Output of coated paperboard will increase due to expanding shipments of food, beverages, and other items requiring such packaging.

TiO2 is a key ingredient in paper production, as brightness and opacity are among the chief characteristics differentiating paper quality. The types of paper that utilize the pigment and their applications are given below. Paper manufacturers employ the highest loadings of TiO2 pigment in coated paperboard and paper laminate products.

Type of Paper	End Use
Bleached board	Packaging
Coated paperboard	Food packaging
Coated free-sheet	Premium magazines, advertisements
Coated groundwood	Catalogs, weekly magazines
Paper laminate	Countertops, furniture, wall board
Uncoated free-sheet	Printing and writing paper

Demand for printing and writing paper is undergoing structural declines due to the use of digital platforms. Sales of paperboard and other types of packaging papers face competition from plastic and other packaging mediums. Furthermore, lower-cost imports of paper products from Asian countries are limiting growth in US production.

**Pharmaceuticals:**

Little relevant data obtained at this time.

**Titanium Metal:**

US demand for titanium metal is forecast to total 100,000 metric tons in 2020, representing annual growth of 3.9% from 82,500 metric tons in 2015. Demand figures include consumption of sponge and scrap. Imports of sponge and scrap will continue to represent an important source of titanium metal for the US. Suppliers of titanium metal benefit from a lack of comparable substitutes for the material. Nevertheless, in applications where titanium’s high strength-to-

weight ratio is desired, substitutes include aluminum, composites, intermetallic, steel, and super alloys. In applications that require corrosion resistance, alternatives include aluminum, nickel, specialty steels, and zirconium alloys.

In value terms, US demand for titanium metal is forecast to total \$370 million in 2020, representing annual gains of 4.3% from \$300 million in 2015.

### ***Electronics:***

#### **Lithium Titanate (Batteries)**

Currently, global lithium battery anode materials industry is concentrated in China and Japan, which occupy more than 95% of anode materials sales worldwide. Japanese enterprises are in a leading position technologically while China boasts obvious cost advantages in anode materials production because of abundant graphite mineral resources.

China produced 122.5 kilotons of anode materials in 2016, up 68.3% year on year. Driven by new energy vehicle demand, China's production of anode materials is expected to register a high CAGR (compounded annual growth rate) of 30-35% in upcoming years, and then reach 295 kilotons in 2020.

In 2016, BTR, Hitachi Chemical, Shanshan, Mitsubishi Chemical, Nippon Carbon and JFE Chemical took top six positions in global anode materials market share ranking (by sales volume), claiming a combined 71.1% share, with Hitachi Chemical, Shanshan, Nippon Carbon and JFE Chemical specializing in artificial graphite, BTR and Mitsubishi Chemical in natural graphite.

So far, China has established a relatively complete industrial chain for anode materials, with three regions (i.e. Pearl River Delta, Yangtze River Delta, and Central China (Hunan and Henan) formed. With a high regional concentration, the number of anode materials production enterprises in the three regions accounts for over 80% of the national total.

Major Producers of Lithium Titanate Batteries:

- Yinlong Group
- Anhui Tiankang
- ALTI
- Toshiba
- Titan Kogyo
- Sichuan Xingneng New Materials
- Shenzhen Tianjiao Technology
- BTR Nano Technology

<http://www.prnewswire.com/news-releases/global-and-china-lithium-ion-battery-anode-material-industry-report-2017-2020-300428020.html>

**Other Applications**

Consumption of TiO<sub>2</sub> pigment in all other applications, as an aggregate, is projected remain unchanged at 38,000 metric tons in 2020. Falling shipments of textile fibers and fabrics in real terms will drive declines in demand for TiO<sub>2</sub>. However, further decreases will be prevented by rising shipments of the various durable and nondurable goods included in this segment that utilize TiO<sub>2</sub>. Production of ceramics, floor coverings, and roofing granules is expected to expand as building construction activity increases. Growth in consumer spending will drive shipments of items such as ink, personal care products, and pharmaceuticals.

This segment includes catalysts, ceramics, coated fabrics and textiles, floor coverings, food coloring, printing and packaging ink, personal care products (e.g., toothpaste), pharmaceuticals, and roofing granules. In foods, personal care products, and pharmaceuticals, TiO<sub>2</sub> pigment is primarily used to impart whiteness and brightness.

**Purity Levels:****Food -**

TITLE 21—FOOD AND DRUGS  
CHAPTER I—FOOD AND DRUG ADMINISTRATION  
DEPARTMENT OF HEALTH AND HUMAN SERVICES  
SUBCHAPTER A—GENERAL

**PART 73 – LISTING OF COLOR ADDITIVES EXEMPT FROM CERTIFICATION****Subpart A—Foods**

Sec. 73.575 Titanium dioxide.

(a) *Identity.* (1) The color additive titanium dioxide is synthetically prepared TiO<sub>2</sub>, free from admixture with other substances.

(2) Color additive mixtures for food use made with titanium dioxide may contain only those diluents that are suitable and that are listed in this subpart as safe in color additive mixtures for coloring foods, and the following: Silicon dioxide, SiO<sub>2</sub> and/or aluminum oxide, Al<sub>2</sub>O<sub>3</sub>, as dispersing aids—not more than 2 percent total.

(b) *Specifications.* Titanium dioxide shall conform to the following specifications:

Lead (as Pb), not more than 10 parts per million.

Arsenic (as As), not more than 1 part per million.

Antimony (as Sb), not more than 2 parts per million.

Mercury (as Hg), not more than 1 part per million.

Loss on ignition at 800 deg. C. (after drying for 3 hours at 105 deg. C.), not more than 0.5 percent.

Water soluble substances, not more than 0.3 percent.

Acid soluble substances, not more than 0.5 percent.

TiO<sub>2</sub>, not less than 99.0 percent after drying for 3 hours at 105 deg. C.

Lead, arsenic, and antimony shall be determined in the solution obtained by boiling 10 grams of the titanium dioxide for 15 minutes in 50 milliliters of 0.5N hydrochloric acid.

(c) *Uses and restrictions.* The color additive titanium dioxide may be safely used for coloring foods generally, subject to the following restrictions:

(1) The quantity of titanium dioxide does not exceed 1 percent by weight of the food.

(2) It may not be used to color foods for which standards of identity have been promulgated under section 401 of the act unless added color is authorized by such standards.

(d) *Labeling.* The label of the color additive and any mixtures intended solely or in part for coloring purposes prepared therefrom shall conform to the requirements of 70.25 of this chapter.

(e) *Exemption from certification.* Certification of this color additive is not necessary for the protection of the public health and therefore batches thereof are exempt from the certification requirements of section 721(c) of the act.

<http://www.accessdata.fda.gov/scripts/cdrh/cfdocs/cfCFR/CFRSearch.cfm?fr=73.575>

### **Titanium Dioxide Industry in the U.S. - Trends**

*\*Note: The following information was taken from "Titanium in the US Industry Report" by Fredonia*

US demand for titanium dioxide pigment is expected to total 800,000 metric tons in 2020, representing 1.4% annual gains from 747,000 metric tons in 2015. Continued expansion in building construction activity will provide the primary impetus for growth, due to its position as a major market for paint and plastic.

Sales of titanium dioxide pigment to paint producers are projected to expand 1.9% per year to 490,000 metric tons in 2020, representing the largest and fastest-growing discrete segment. Suppliers will benefit as US paint, coating, and adhesive shipments are set to expand 2.7% annually in real (inflation-adjusted) terms from 2015 to 2020.

### **Historical Trends**

US titanium mineral concentrates demand totaled 1.1 million metric tons in 2015; declines averaged 2.4% over the 2005-2015 decade. The production of titanium dioxide (TiO<sub>2</sub>) pigment accounts for the majority of titanium minerals consumed in the US. The diversity of applications for both pigment and metal, and the lack of good substitutes, assures a minimum level of demand. However, important end markets such as building product and transportation equipment manufacturing exhibit strong cyclical, which causes substantial year-on-year fluctuations.

Demand for titanium minerals grew 8.6% in 2006, the fastest growth of the 2005-2015 decade. Gains were supported by a 6.3% increase in sales of concentrates to TiO<sub>2</sub> pigment producers that year. Demand for titanium minerals hit a peak of 1.6 million metric tons in 2007, propelled

by continued increases in sales of concentrates to TiO<sub>2</sub> pigment producers of 4.9% that year. In 2014, some larger end markets for titanium minerals experienced declines in real (inflation-adjusted) value terms; for instance, shipments of plastic resins, rubber, and fibers fell 2.0% and paper product shipments receded 1.0%. These declines, in addition to ongoing initiatives by paint and coatings manufacturers to decrease TiO<sub>2</sub> consumption, resulted in demand for titanium minerals plunging 14% that year, the fastest drop of the decade. Demand continued to slide in 2015, falling 7.6% to the lowest point of the historical period.

In value terms, US demand for titanium mineral concentrates amounted to \$670 million in 2015; increases averaged 6.2% over the 2005-2015 decade. Value demand exhibited volatility during the majority of the period. Sharp price spikes that began in 2011 caused a substantial surge in value demand. The main driver of the titanium mineral price spikes was the rebounding global demand for titanium dioxide pigment in the years following recessionary declines in 2008-2009. After having reduced pigment capacity due to a drop in sales and weak profit margins leading into the global recession, strong sales starting in 2011 resulted in many pigment producers operating at close to 100% of capacity. The resurgence in global sales resulted in sharp pigment price increases, and since pigment production accounts for the majority of mineral demand, mineral prices also surged.

Demand for titanium minerals in value terms dropped to a trough of \$460 million in 2009. Titanium concentrates find use in a variety of manufacturing end markets, from transportation equipment to chemical products. Manufacturers' shipments as a whole fell 19% to a decade trough of their own in 2009 due to the 2007-2009 recession. In 2013, demand vaulted to a peak of \$1.1 billion following a 55% increase, the fastest of the decade. Value gains were propelled by soaring prices as volume gains remained stable. However, value demand retreated 27% in 2014, the quickest drop of the decade, as prices decreased and demand fell in volume terms. As prices and demand in volume terms continued to shrink, demand in value terms also contracted 20% in 2015.

#### Segmentation & Forecasts

US demand for titanium mineral concentrates is forecast to total 1.3 million metric tons in 2020, representing annual growth of 3.4% from 1.1 million metric tons in 2015. Imports will continue to fulfill the majority of domestic orders, as US production is small relative to demand. US production of TiO<sub>2</sub> pigment accounted for 95% of the minerals consumed in 2015, while the production of titanium metal sponge and other products represented the remainder. The demand figures for mineral concentrates represent TiO<sub>2</sub> content.

Titanium minerals – ilmenite, leucosene, and rutile – are found in mineral sand deposits, which also contain zircon, an element used in ceramics and refractories. The value of titanium-bearing minerals depends on their TiO<sub>2</sub> content: rutile features the highest at 92-96%, followed by leucosene at 65-91%, and ilmenite with 35-65%. Due to the relatively low TiO<sub>2</sub> content of ilmenite, the titanium mining industry produces beneficiated products from the mineral, which include slag, synthetic rutile, and upgraded slag. The beneficiated products feature TiO<sub>2</sub> contents of 75-95%.

In value terms, US demand for titanium mineral concentrates is forecast to total \$845 million in 2020, representing annual gains of 4.8% from \$670 million in 2015. Volume growth and slight price increases are expected to boost the total value of minerals sold. Increased production of TiO<sub>2</sub> pigments, the largest product segment, will drive demand.

#### Titanium Dioxide Pigment

Production of TiO<sub>2</sub> pigment is expected to generate the majority of mineral concentrate sales in 2020, at 1.2 million metric tons, after expanding 3.5% annually from volumes in 2015. A continued rebound in building construction will support increases in paint and plastic production, generating demand for pigment, which will stimulate US TiO<sub>2</sub> pigment production and consumption of the required concentrates. The high-quality pigment made in the US will also drive export sales, further supporting US pigment production.

TiO<sub>2</sub> pigment – a white, refractive, and ultraviolet-radiation absorbing colorant – is used in paint, plastic, and paper. Despite the high cost, it is widely employed, as virtually no other pigment exhibits its properties, particularly with respect to opacity, whiteness, and durability. Two production methods exist – the chloride process and the sulfate process. US suppliers utilize the former because it results in a superior pigment. However, the chloride process is more expensive, which elevates the cost of pigment manufactured in the US. The chloride process entails the chlorination of the feedstock minerals, followed by purification and oxidation. The sulfate process consists of digesting the titanium minerals in sulfuric acid, followed by clarification, hydrolysis, filtration, and calcinations.

Worldwide, it is estimated that each process accounts for about half of pigment production. The majority of Chinese producers employ the sulfate process due to its lower cost. In addition, Chinese manufacturers have increased capacity for pigment that can be produced via the sulfate process in part because the surge in prices over the historical period prompted pigment consumers worldwide to increasingly seek cheaper material. In addition, consumers (e.g., paint producers) increased the use of pigments that extend or replace TiO<sub>2</sub>, such as kaolin. Nevertheless, US producers enjoy considerable sales to both domestic and export markets, stemming from the desirability of TiO<sub>2</sub> pigment produced using the chloride process.