

Revised 1969

Building Layouts for Confined Beef Finishing

Dennis M. Ryan, extension agricultural engineer

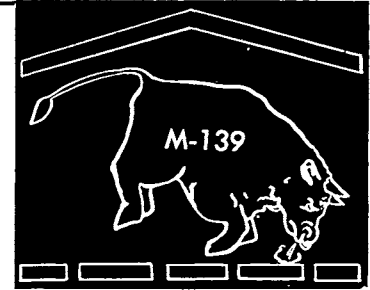

AGRICULTURAL EXTENSION SERVICE ■ UNIVERSITY OF MINNESOTA

Beef can be finished in an open-cold or closed-warm building. Bedding can be used in a building that has a solid floor, but it should not be used in a building with a slatted floor.

The open-cold building should remain open during the winter period. If this type of building is closed during cold weather, the warm humid air from the cattle will condense as frost on the under surface of the cold roof. When the outside temperature rises, the frost will melt and a "gentle rain will fall from above."

The closed-warm building should be extremely well insulated. It should have a limited number of windows or possibly none. Most warm confined beef buildings in our area could use artificial heat during the colder months to

eliminate fog. The temperature should be regulated by a well designed ventilation system.

The choices of construction we have laid out for you are: (1) Cold-open building with solid floor and bedding, (2) Cold-open building with slatted floor and no bedding, and (3) Warm building with slatted floor and no bedding.

Cold-Open Building with Solid Floor and Bedding

If you wish to confine beef and use bedding, we suggest you use the layout shown in figure 1. The building will handle 200 head of beef at finished weights, based on 30 square feet per head not including the cleaning slab.

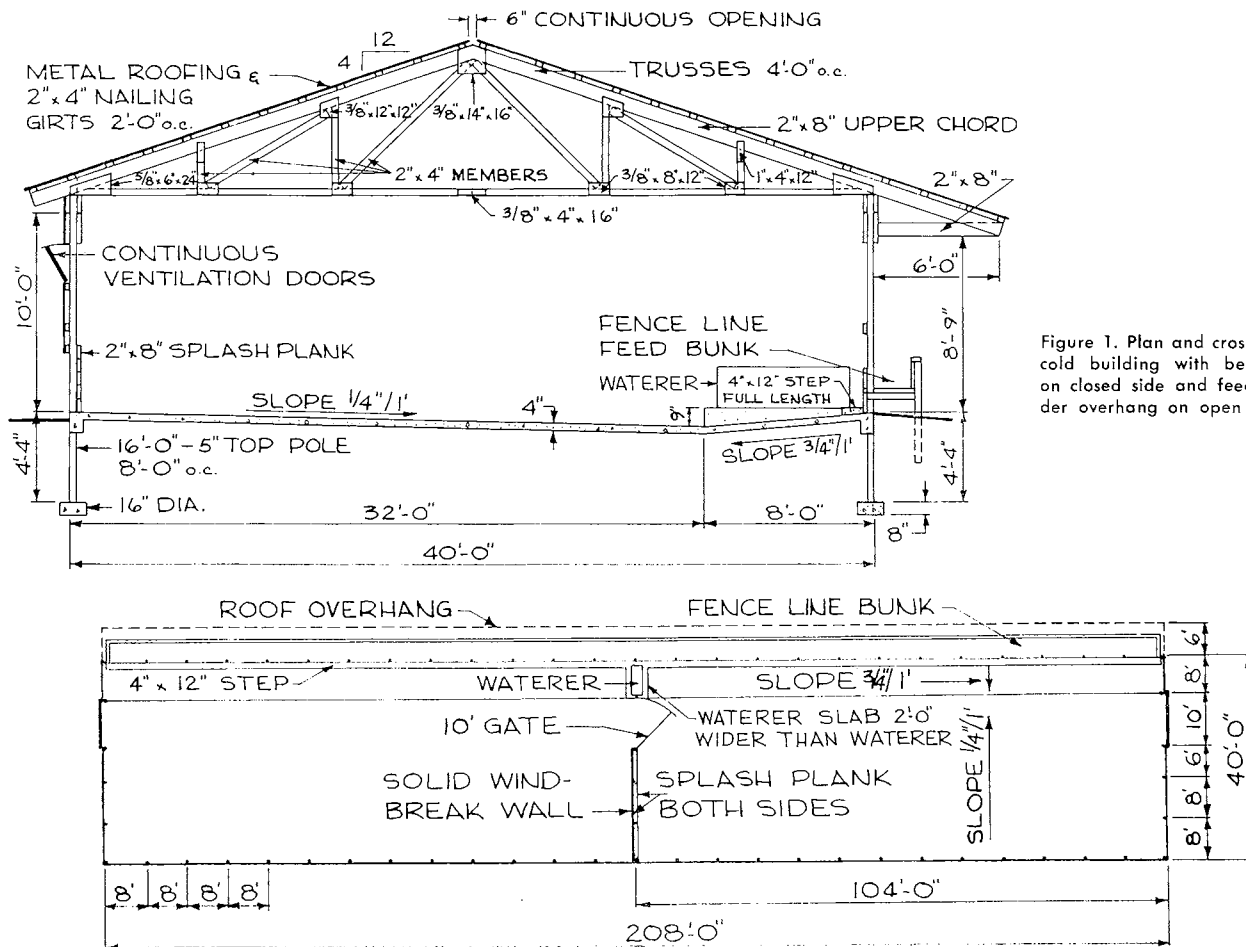

Figure 1. Plan and cross section of cold building with bedded area on closed side and feed bunk under overhang on open side.

This archival publication may not reflect current scientific knowledge or recommendations.
Current information available from University of Minnesota Extension: <http://www.extension.umn.edu>.

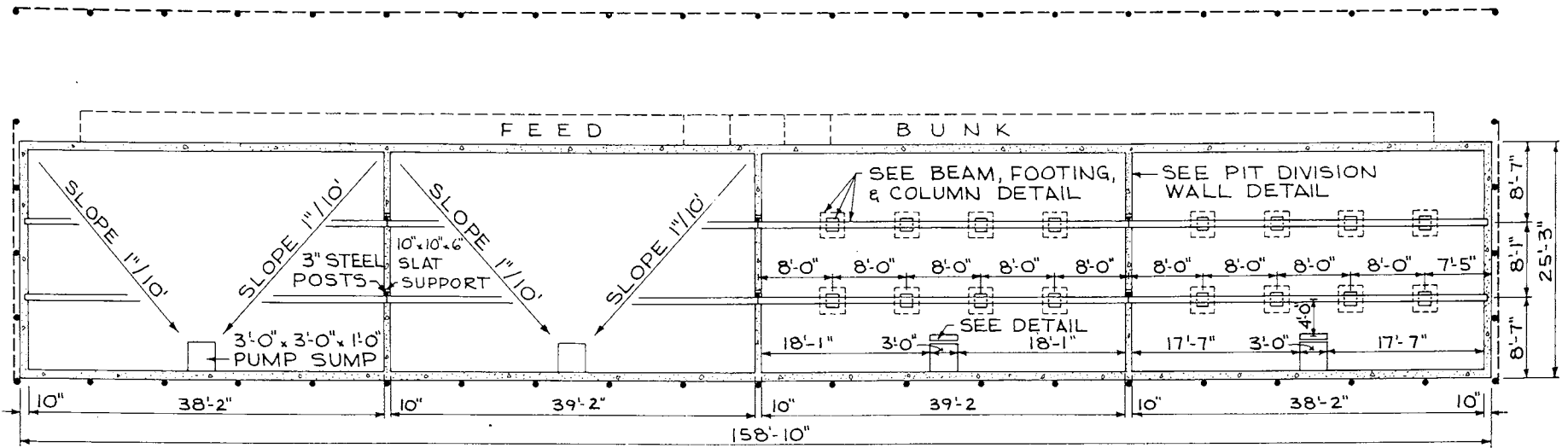

Figure 2. Plan view of the pit of a cold slatted floor building.

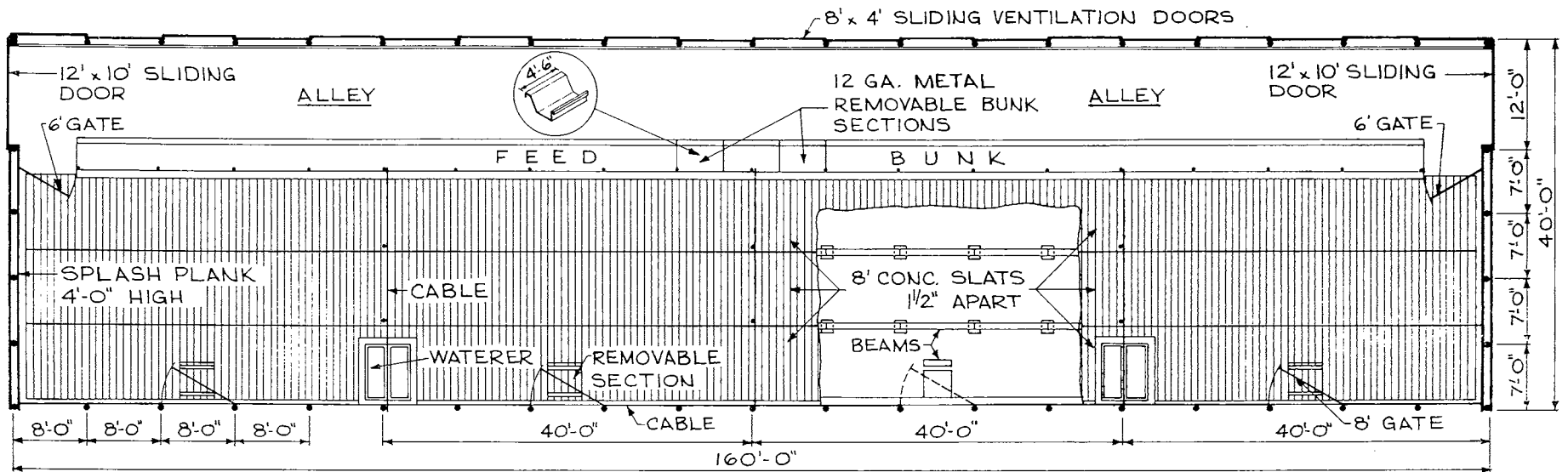

Figure 3. Plan view of floor above pit of a cold slatted floor building.

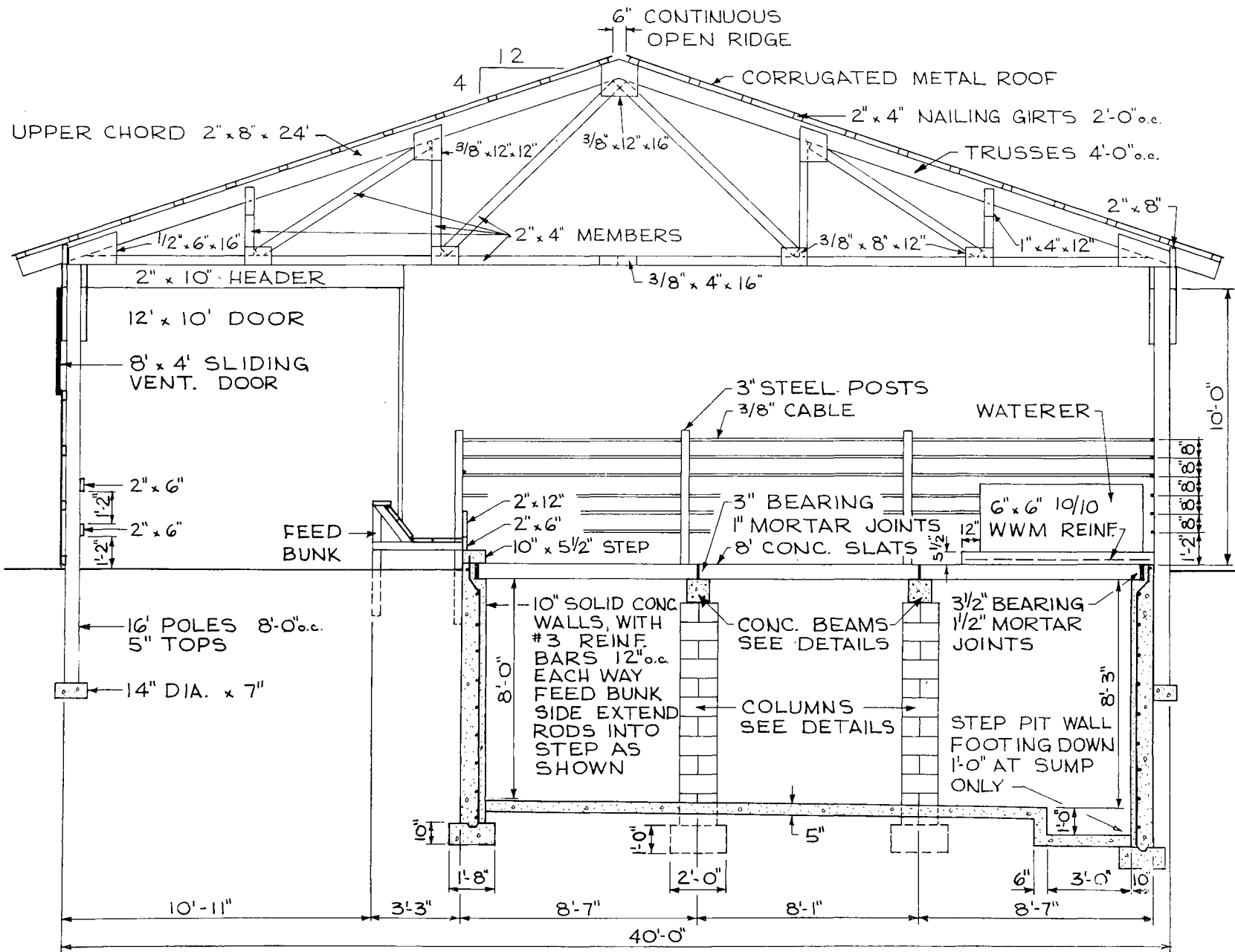

Figure 4. Cross section of a cold slatted floor building.

The fenceline bunk is constructed under an overhang along the open side of the building. Allow a 1-foot space per head along the bunk. The concrete floor under the bedded area slopes 1 inch in 4 feet for 32 feet from the back toward the front of the building. At a distance of 8 feet from the front of the building, this floor joins with the concrete floor that slopes three-fourths of an inch per foot away from the bunk.

A step 4 inches deep and 12 inches wide should be constructed along the bunk to prevent the cattle from backing up and defecating in the bunk.

The location of the waterer is of vital importance. Do not locate it in or adjacent to the bedded area or spillage and drippings from the mouths of cattle will keep a good sized area of the bedded area continuously wet. Locate the waterer adjacent to the bunk as shown in figure 1. The concrete platform supporting the waterer should be large enough to provide a 12-inch-wide step on the three sides of the tank where the cattle will drink. This step which varies in depth from 4 to 9 inches due to the slope of the slab along the bunk will prevent the cattle from defecating in the waterer.

The cattle will keep the 8-foot slab along the bunk fairly clean. You will have to clean the area just below the 8-foot slab at regular intervals. The intervals between cleanings will vary with the number and weight of cattle and the season of the year.

This building has a trussed roof for easier cleaning, complete concrete floor, and splash planks on three sides of each section. The windbreak wall extends to the roof from the back of the building to the cleaning gate.

Ventilation and Wind Protection

To eliminate drafts and condensation in winter and provide good ventilation both winter and summer, the following points of construction are recommended.

1. Construct a solid wind wall approximately every 100 feet. This wall should extend up to the roof.

2. If wind is whipping around the corner into the building you may have to construct a stub high board fence at right angles to the ends of the building just in front of the cleaning door. This fence should be 10 feet high and about 20 feet long. Construct the fence with 8-inch boards set vertically 1 inch apart.

3. Close the upper part of the open side so the opening is not more than 10 feet high. This helps to prevent back suction off the roof. If you still have back suction you can hang 4-foot snow fencing below this closed-in area.

4. Allow a 6-inch continuous opening along the ridge. This continuous opening will allow the warm air to escape rather than condense on the inside of the cold roof.

5. Provide continuous ventilation doors along the closed side that can be dropped down during the summer months. These doors can be framed to fit between two nailing girts if the nailing girts are butted rather than lapped. The ventilation doors should be 8 feet long and extend from center of support post to center of support post.

Cold-Open Building with Slatted Floor and No Bedding

Any beef feeder or prospective beef feeder who has not invested heavily in existing buildings or equipment

should take a good hard look at the cold-open building with slatted floor before expanding his present layout or constructing an entirely new system.

Some of the advantages of this system are:

1. Entire enterprise under roof.
2. No rain soaked feed in warm weather.
3. No snow shoveling or plowing in winter.
4. Considerable saving in bedding cost.
5. Saving in labor by handling manure as a liquid.
6. Apparently better feed conversion than obtained with a conventional system where cattle are fed outside.

The plan view of the pit is shown in figure 2. The arrangement of the floor above the pit is shown in figure 3. The complete cross-section of the cold slatted floor beef building is shown in figure 4.

The 160' x 40' cold slatted floor building will house 200 head of cattle at finished weights. Each of four pens holds 50 head, allowing 18 square feet per head. The building is pole construction and has trussed rafters spaced 4 feet apart.

The following points of construction or layout will contribute to the successful operation of a cold slatted floor beef finishing building.

1. The open side of the building must face south.
2. The south side of the building should have a high enough opening to allow the sun's rays to reach the area along the bunk.
3. The liquid manure storage pit should be divided into smaller units so the agitator pump is within 30 feet of any particle of liquid manure.
4. The division walls must be designed to withstand liquid pressure on one side when there is no pressure on the other side. For design purposes the assumption should be made that the wall is not fixed at the top.
5. Access to a sump located in each pit should be provided so the flow from a pump sitting directly over the sump can be directed to any area within the pit at the time of agitation.
6. A step should be constructed along the bunk and around the waterers to prevent the cattle from defecating in either the bunk or waterers.
7. A continuous 6-inch opening at the ridge should be provided for winter ventilation.
8. Doors along the back of the building should be installed for cross ventilation in the summer.

Lower Floor Construction

Each small pit is approximately 24' x 40'. The average depth is about 8 feet. The 5-inch thick pit floor slopes 1 inch in 10 feet from the farthest corner toward a clean-out sump located adjacent to the wall on the open side (figure 2). The sump is 3' x 3' and 1 foot deep. Make all four corners of each small pit the same elevation.

The outside solid concrete walls are 10 inches thick and reinforced with #3 bars 12 inches on center both ways. The division walls are 10 inches thick and require special reinforcing and a reinforced footing as shown in figure 5. The footing is 5 feet wide and 1 foot thick. Number 5 vertical reinforcing bars are spaced 8 inches apart. They start horizontally in the footing and are bent up in each face as shown in figure 5. At a height of 3 feet above the pit floor every other bar terminates. Additional

#5 bars are placed in the upper part of the footing 12 inches on centers both ways. The horizontal #3 bars in the division walls are spaced 12 inches on centers on both faces. Figure 6 shows how the #3 horizontal bars in the division walls tie into the outside wall of the pit.

Upper Floor Construction

The total width of the building is 40 feet. The slats take up 24 feet and the bunk and alley use the other 16 feet. A 10-foot-high open side will allow the sun's rays to reach in about 24 feet in the winter; hence the slatted area is restricted to 24 feet.

The bunk may be constructed of wood or precast concrete. A gate at each end of the bunk and two removable sections of bunk near the center of the building (figure 3) will allow you to move cattle from the pens into the alley for sorting or working. The roof on the back of the building could be extended about 3 feet for a distance

of 20 to 30 feet to enclose an area for a working chute. A loading chute could be located just outside of the building at the end of the working chute. The alley floor can be dirt because it will always be dry.

The concrete slats are 8 feet long and spaced 1½ inches apart. The width and depth of the slat vary with the span (figure 7). For an 8-foot span the width and depth are both 6 inches. A #6 reinforcing bar is needed in the bottom and a #3 bar in the top.

The slats are supported on footings, columns, and beams as shown in figure 8. The columns are spaced 8 feet apart. The 8-foot-long precast beams are 10" x 10" with 2 #6 bottom reinforcing bars and 2 #3 top bars. The slats are held in position by placing mortar at both ends and in between the slats at the ends (figure 8).

Directly over the sump a section of short slats, held together with ¼" x 4" bars, can be removed to allow placing of pump in the sump (figure 9). One end of this slat section rests on a rabbet in the outside wall, the other

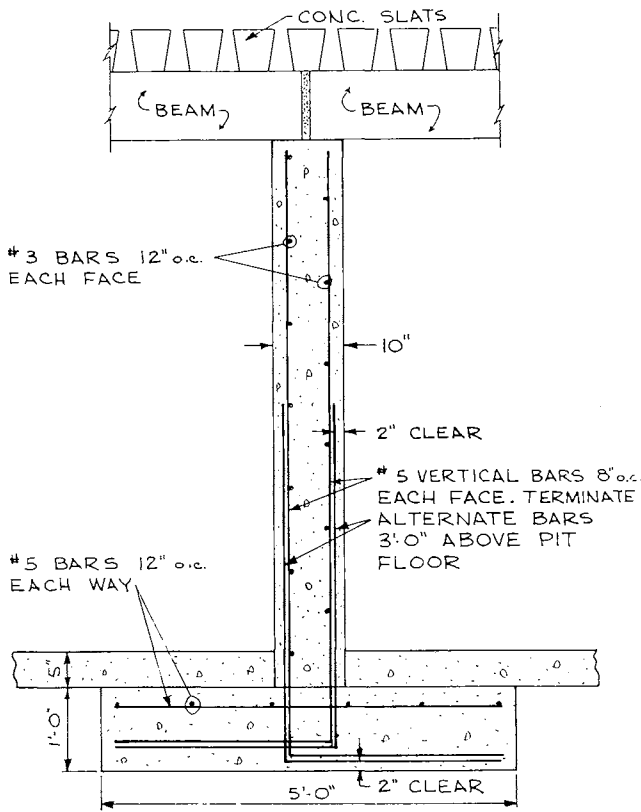

Figure 5. Footing size and steel needed in both footing and wall when wall is designed as a cantilever wall not fixed at the top.

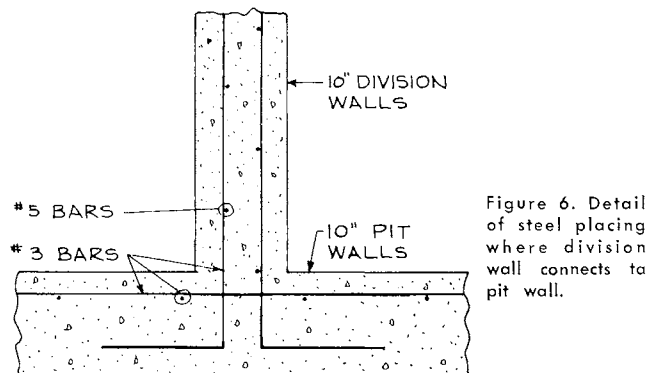
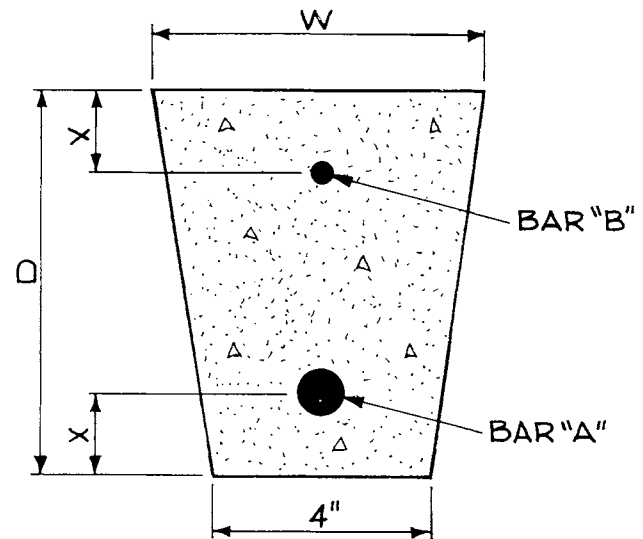
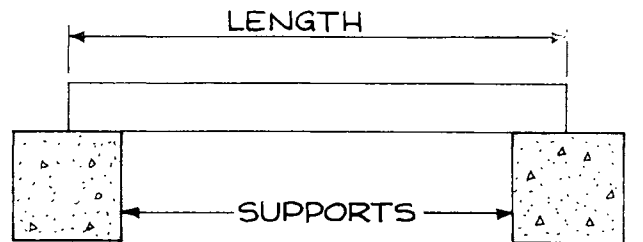

Figure 6. Detail of steel placing where division wall connects to pit wall.



LENGTH	DIMENSIONS			BAR SIZE	
	D	W	X	A	B
6'-0"	6	6	1½	NO. 5 (5/8)	NO. 3 (3/8)
8'-0"	6	6	1½	NO. 6 (3/4)	NO. 3 (3/8)
10'-0"	7½	6	1½	NO. 6 (3/4)	NO. 3 (3/8)
12'-0"	7½	6	1½	NO. 7 (7/8)	NO. 3 (3/8)

Figure 7. Slat dimensions and reinforcing needed.

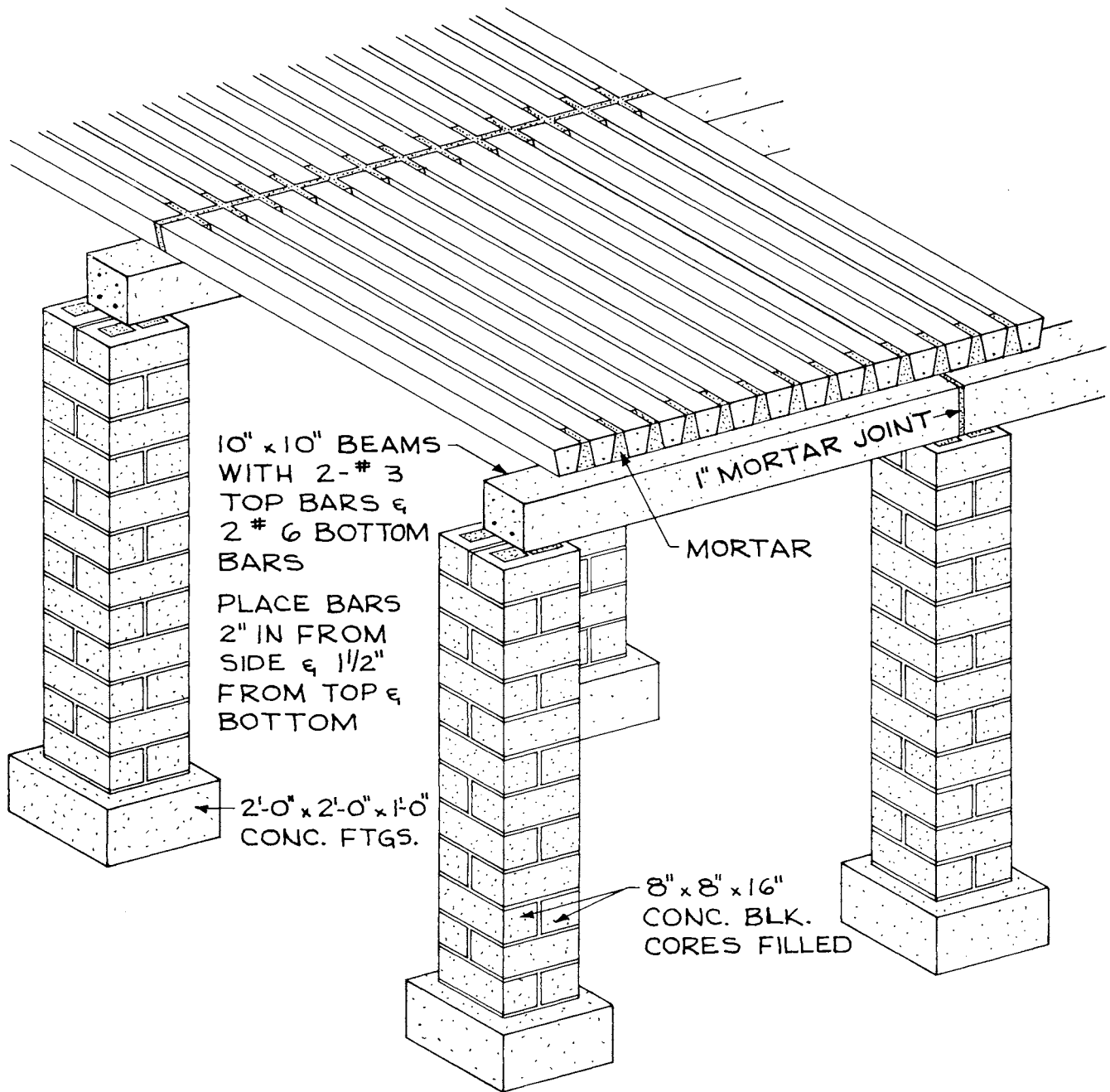

Figure 8. Details of faotings, columns, and beams to support slats in either a cold or warm building.

end is supported by an 8" x 10" beam which rests on two 8-inch columns. For convenience use the same size reinforcing steel in the short beam as is shown for the main beam in figure 8. In some areas a metal grid to fit the opening in the slats is available.

The waterers are located adjacent to the open side to permit a 6-inch tile to be placed outside the manure pit to enclose the water pipe and electric wiring necessary for the heated waterer. The waterer can sit on a 5½-inch-deep reinforced slab that rests on the slats. Construct the slab so it will extend out 12 inches beyond the waterer on the three exposed sides. This will keep the cattle from defecating in the waterer.

A step 10 inches wide and the depth of a 2 x 6 can be constructed along the bunk to keep the cattle from defecating in the bunk.

Cable may be used along the open side to contain the cattle (figure 4). The division fences may also be constructed with cable and 3-inch steel posts set in the division walls. Figure 10 shows how slats directly over the division walls are supported at the posts. The post is located adjacent to the cross beam. The slat on one side of the post rests on this beam. A 10" x 10" x 6" block of solid concrete is cast on top of the division wall adjacent to the post as a support for the slat on the other side of the post.

A continuous 6-inch opening at the ridge (figure 4) is necessary to allow humid air to escape before it condenses on the underside of a cold roof.

Sliding 8' x 4' doors suspended from a light track at every other pole spacing along the back of the building should be opened for summer ventilation (figures 3-4).

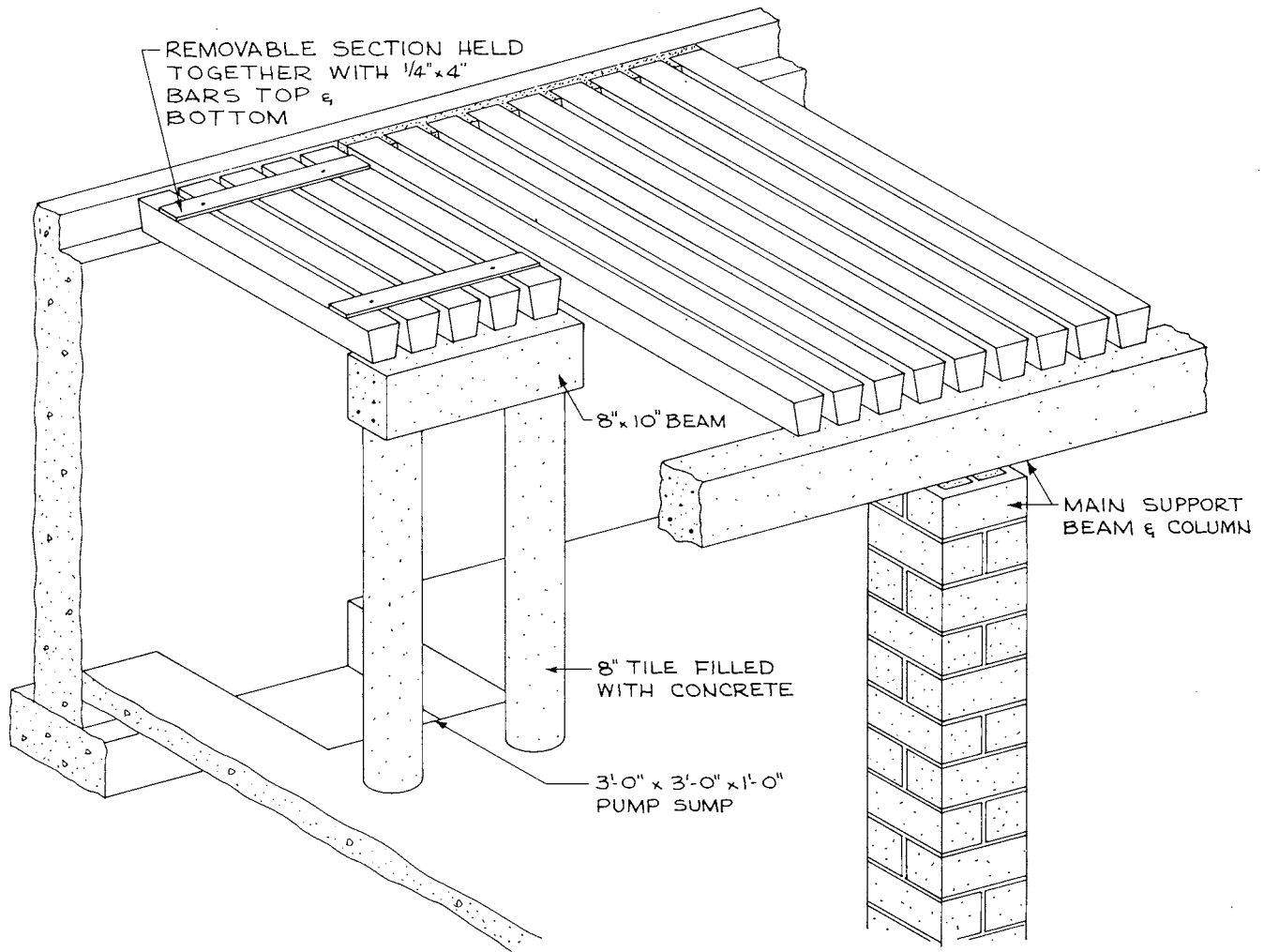

Figure 9. Detail of supports and short slats over the sump.

The back wall of the alley should be protected with spaced 2 x 6's on the inside of the poles if you are going to work cattle in the alley.

The style of the pen gates and doors at each end of the alley is immaterial, but they should be durable.

Warm Building with Slatted Floor and No Bedding

The plan view of the pit is shown in figure 11. The arrangement of the floor above the pit is shown in figure 12. The complete cross-section is shown in figure 13.

The 100' x 40' warm insulated slatted floor building will house 200 head of cattle at finished weights. Each of four pens holds 50 head allowing 18 square feet per head. The building is frame construction and has trussed rafters spaced 2 feet apart. The roof has a solid deck with shingles. The ceiling has 6 inches of insulation and the walls have 4 inches. There are no windows.

The following points of construction or layout will contribute to the successful operation of a warm slatted floor beef finishing building:

1. An insulated ceiling simplifies the mechanics of both heating and ventilating the building.
2. Artificial heat will help reduce "fog" in cold weather.

3. Pit fans are necessary to control odors and gases.
4. The liquid manure storage pit should be divided into smaller units so the agitator pump is within 30 feet of any particle of liquid manure.

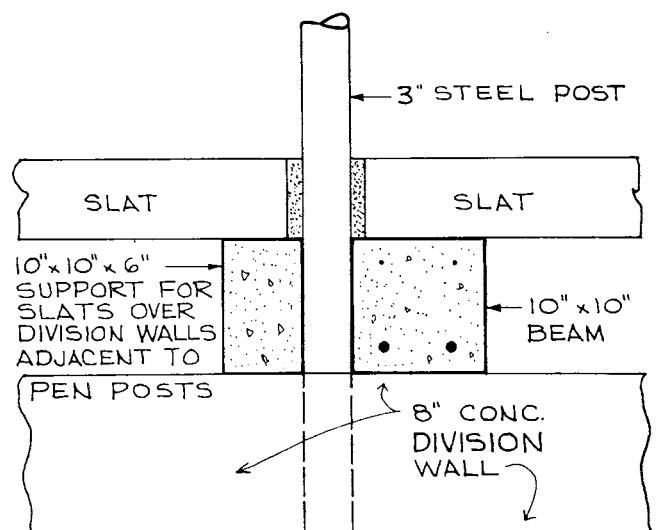

Figure 10. Detail of placing post in division wall for pen partitions and how slat directly over the division wall is supported.

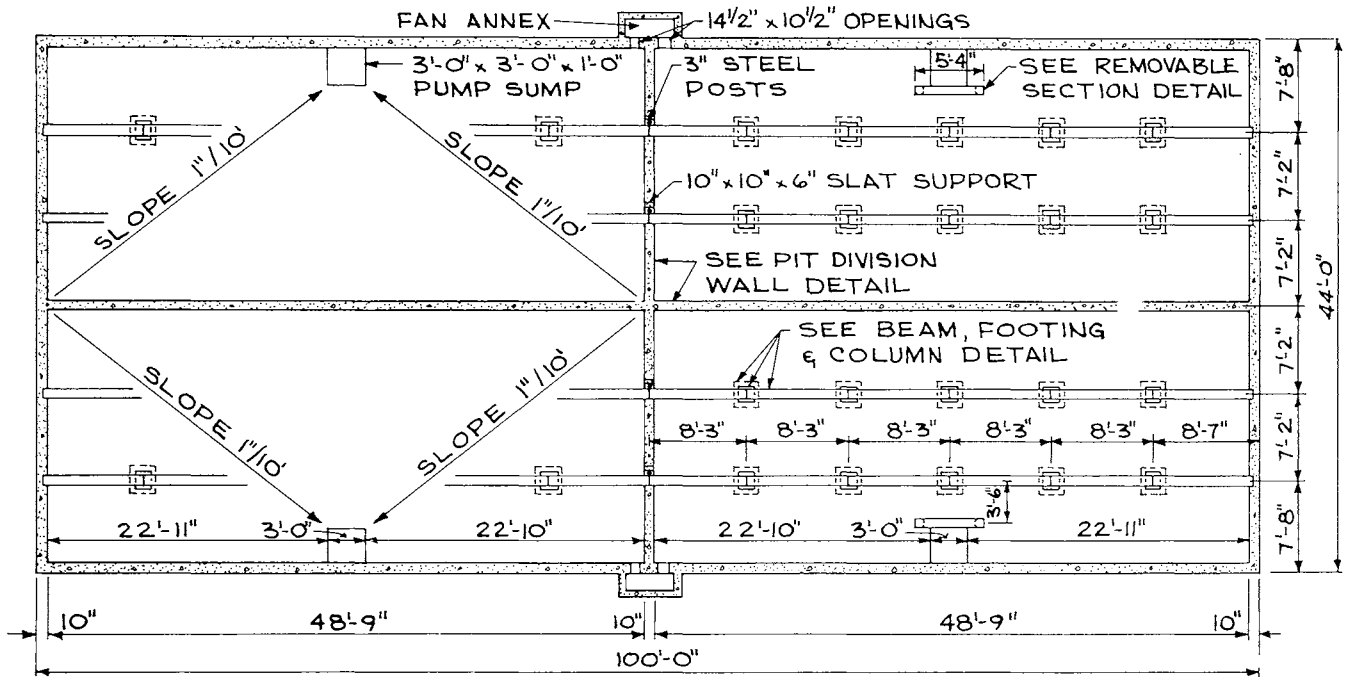

Figure 11. Plan view of the pit of a warm slatted floor building.

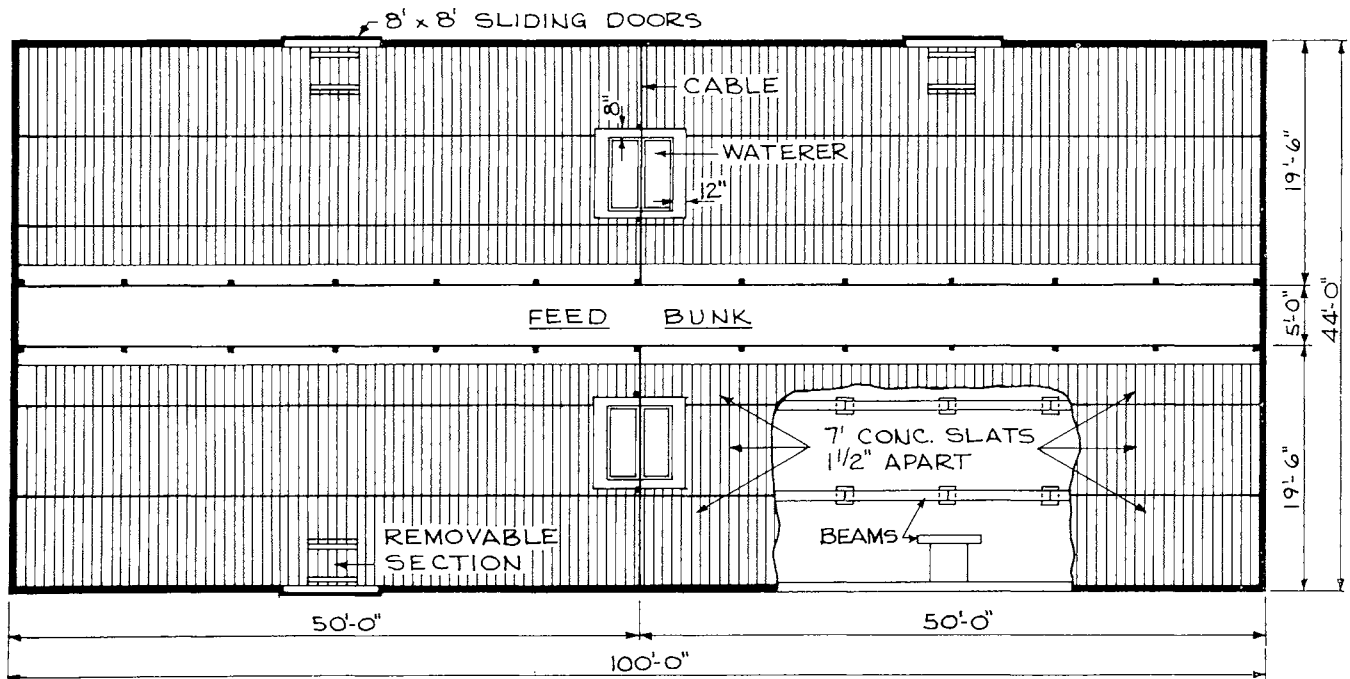

Figure 12. Plan view of the floor above the pit in a warm slatted floor building.

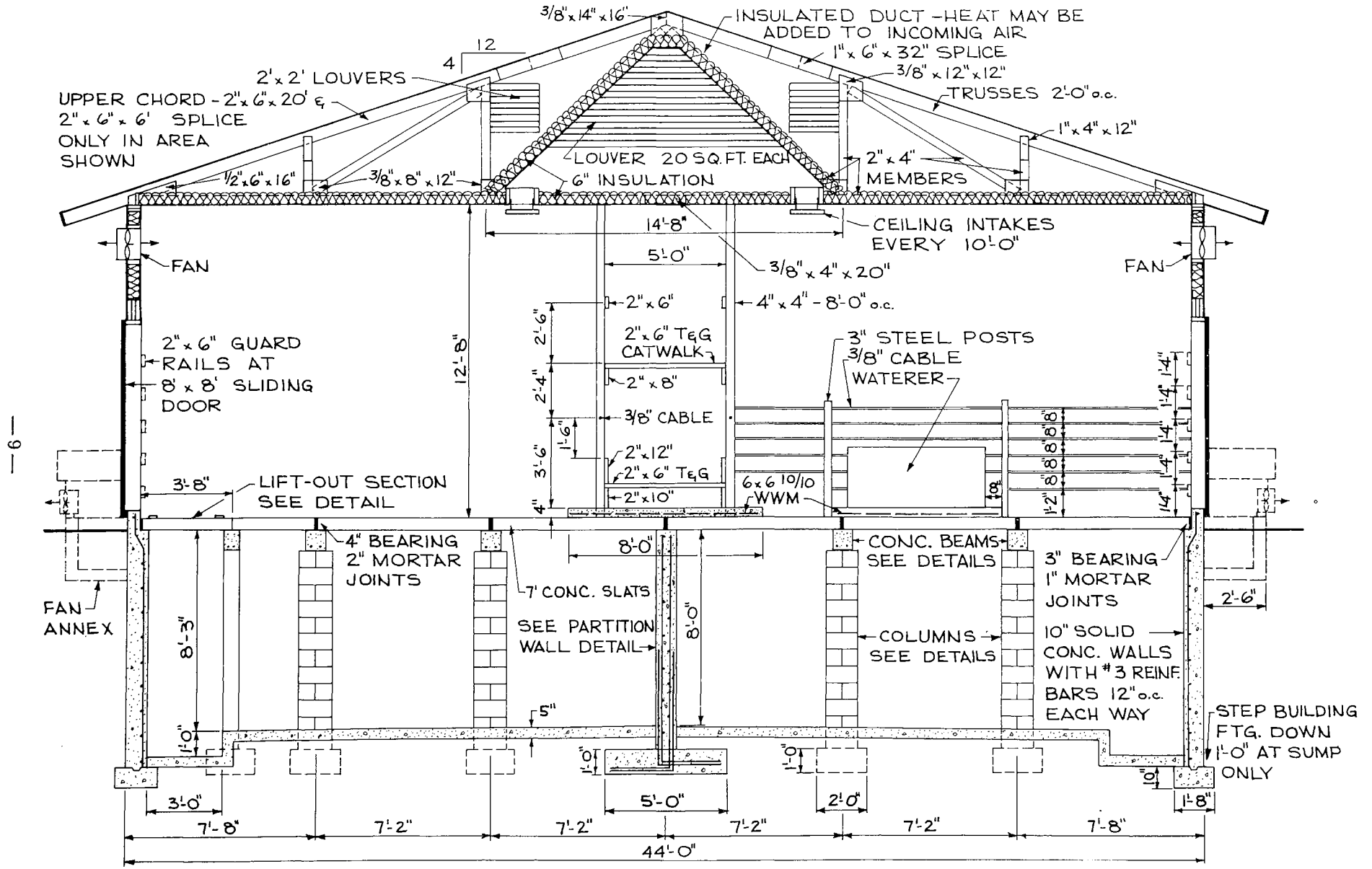

Figure 13. Cross section of a warm slatted floor building.

5. The division walls must be designed to withstand liquid pressure on one side when there is no pressure on the other side. Assume the wall is not fixed at the top.
6. Access to a sump located in each pit should be provided so the flow from a pump sitting directly over the sump can be directed to any area within the pit at the time of agitation.
7. A step should be constructed along the bunk and around the waterers to prevent the cattle from defecating in either the bunk or waterers.

Lower Floor Construction

Each sectional pit is approximately 22' x 50'. The average depth is about 8 feet. The 5-inch thick pit floor slopes 1 inch in 10 feet from the farthest corner toward a clean-out sump located adjacent to the outside wall (figure 11). The sump is 3' x 3' x 1' deep. Make all four corners of each small pit the same elevation. The outside solid concrete walls are 10 inches thick and reinforced with #3 bars 12 inches on center both ways.

A 5-foot-wide bunk divides the building down the middle. The bunk sits on a reinforced slab directly over a longitudinal reinforced partition wall (figure 13). A tongue and groove "catwalk" is constructed above the bunk to allow easy inspection of cattle. The throat height on the bunk can be any height because there will be no accumulation of snow or manure along the bunk. A step along the bunk will prevent cattle from defecating in the bunk (figure 13).

The slats are 7 feet long and spaced 1½ inches apart. The details of construction of the division walls (figures 5 and 6), slat dimensions (figure 7), footings, columns, beams to support slats (figure 8), short slats over sump (figure 9), and post placing in division walls (figure 10) are the same as for the cold slatted floor described previously.

The waterers are located as shown in figures 12 and 13. They sit on reinforced slabs which extend beyond the waterers to form a step to prevent the cattle from defecating in the waterers.

An 8' x 8' sliding door is hung on the track adjacent to each sump to provide access for the pumping equipment. These doors may also be used for entrance and exit of cattle. Removable 2 x 6 guard rails protect the doors from damage.

Ventilation

The amount of air movement needed for summer ventilation is the determining factor in designing the capacity of any ventilation system.

The system should have an air movement of 200 cubic feet of air per minute (c.f.m.) per 1,000 pounds of live-weight when the building is stocked with the maximum weight of beef. For our building we will use 200 head at a market weight of 1,000 pounds.

$$\text{Total Fan Capacity} = 200 \text{ head} \times 1,000\# \times 200 \text{ c.f.m.} \div 1,000 = 40,000 \text{ c.f.m.}$$

Since distribution is the key to summer air movement, I would select eight reversible fans each with a capacity of 5,000 c.f.m.

These fans should be installed just below the ceiling and spaced on both long walls as shown in figures 13 and 14.

In addition, a fan of 1,200 c.f.m. capacity should be placed in an annex on each side in the middle of the long wall (figures 13 and 14). These fans should sit at an elevation just above the slats. Pit fans will help to control odor and gases and will also remove the minimum amount of air during extremely cold temperatures. One annex will handle two pits if an opening of 14½" x 10½" is made between each pit and the annex. Since the steel in the wall is spaced 12" on center both ways one vertical bar

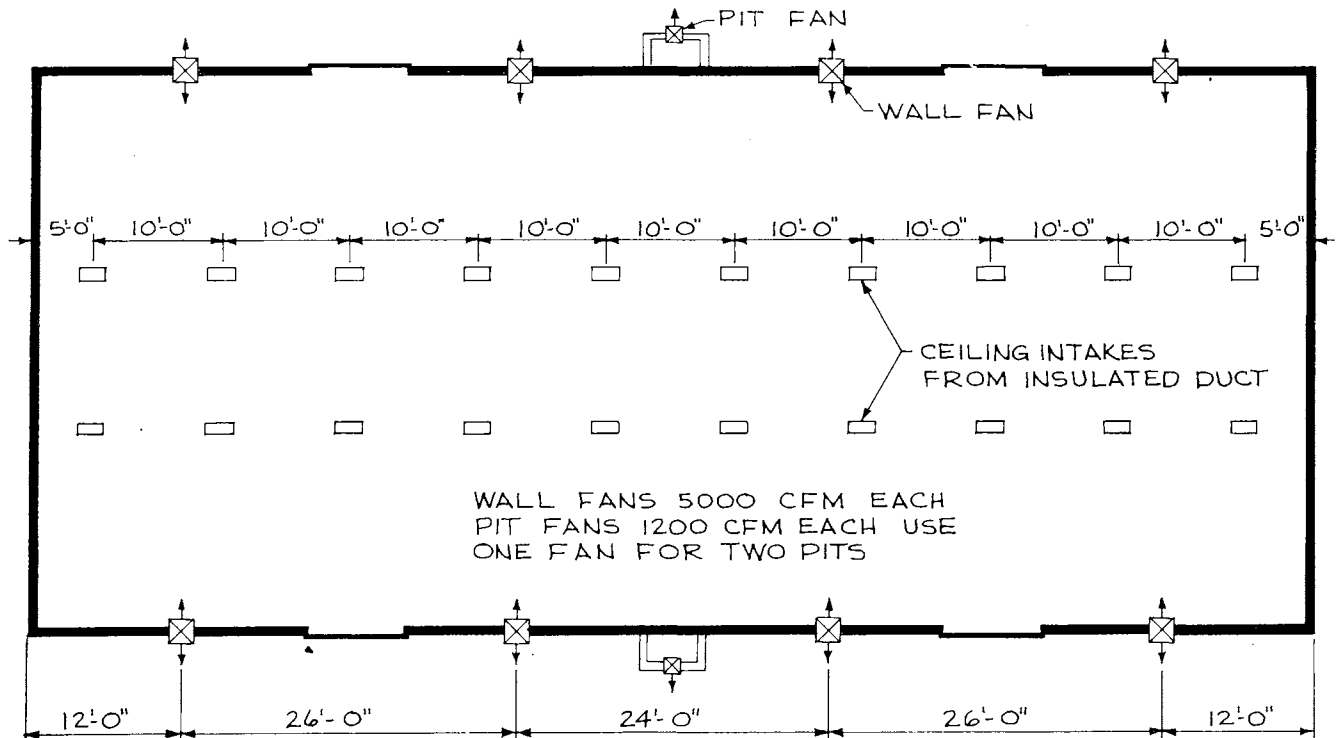

Figure 14. Plan view of location of fans and ceiling intakes.

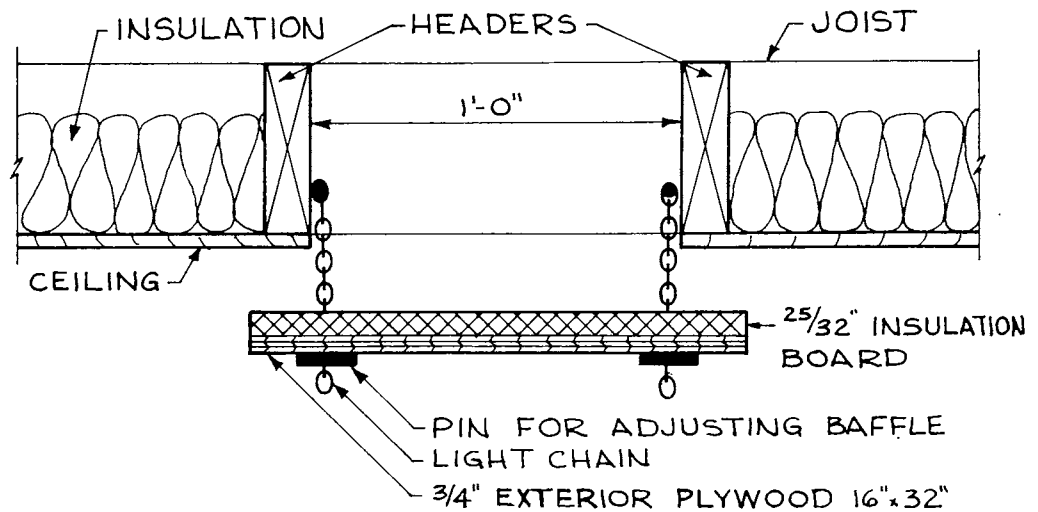

Figure 15. Detail of ceiling intake. The opening is 1 foot 0 inches wide between headers and 2 feet 0 inches long, which is joist spacing.

will have to be cut to make the opening. The height will be 10½" which is the maximum opening possible between two horizontal rods spaced 12 inches apart to still allow the rods to be encased in concrete. The 14½" width of opening is made by using a 2 x 12 form board with a 2 inch thick form board nailed on each side. Adding the nominal dimensions of 1½ + 11½ + 1½ we arrive at 14½. Place the top of the opening at least 6 inches below the rabet and under at least one horizontal bar.

Incoming Air

Considering the possible need for adding heat to incoming air to prevent the formation of fog during extremely cold temperatures, I suggest locating a triangular insulated duct in the loft to distribute incoming air (figure 13).

The air enters the duct through louvers at either end and flows down into the building through ceiling intakes. The ceiling intakes, which are 1 foot wide and 2 feet long are spaced 10 feet apart (figures 14 and 15). A 6-inch-wide intake would be adequate for incoming air in winter but not in summer; therefore it is necessary to construct an

intake 1 foot wide and regulate the flow by moving the baffle plate up or down. A 2-inch clearance between baffle and ceiling for winter and a 4-inch clearance for summer should provide the proper regulation.

The 16" x 32" plywood baffle plate is suspended by four chains. Each chain should be attached about 8" from the end of the plywood. An insulation board on top of the plywood will prevent condensation.

Each end louver should have an area of 20 square feet to allow enough air to enter the duct for summer ventilation. The insulation in the duct will hold the temperature of the incoming summer air fairly constant by reducing the effect of the heat in the loft caused by the sun.

Artificial heat can be piped into this duct. Swinging doors can be installed over the louvers to regulate the flow of outside air into the duct that will mix with the heated air.

We have a similar heating system now being installed in a warm slatted floor beef building at our West Central Experiment Station at Morris, Minnesota. As soon as we have operational information on this system we will pass it on to you.

UNIVERSITY OF MINNESOTA



3 1951 D03 292563 H

Issued in furtherance of cooperative extension work in agriculture and home economics, acts of May 8 and June 30, 1914, in cooperation with the U. S. Department of Agriculture. Roland H. Abraham, Director of Agricultural Extension Service, University of Minnesota, St. Paul, Minnesota 55101.

5M — 12-68