

**SUBSTRUCTURING PRECONDITIONING FOR FINITE ELEMENT
APPROXIMATIONS OF SECOND ORDER ELLIPTIC PROBLEMS.
II. MIXED METHOD FOR AN ELLIPTIC OPERATOR WITH
SCALAR TENSOR**

By

Serguei Maliassov

IMA Preprint Series # 1281

December 1994

**INSTITUTE FOR MATHEMATICS AND ITS APPLICATIONS
UNIVERSITY OF MINNESOTA**

**514 Vincent Hall
206 Church Street S.E.
Minneapolis, Minnesota 55455**

**SUBSTRUCTURING PRECONDITIONING FOR FINITE ELEMENT
APPROXIMATIONS OF SECOND ORDER ELLIPTIC PROBLEMS.
II. MIXED METHOD FOR AN ELLIPTIC OPERATOR WITH
SCALAR TENSOR**

SERGUEI MALIASSOV*

Abstract. This work continues the series of papers in which new approach of constructing algebraic multilevel preconditioners for mixed finite element methods for second order elliptic problems with tensor coefficients on general grid is proposed. The linear system arising from the mixed methods is first algebraically condensed to a symmetric, positive definite system for Lagrange multipliers, which corresponds to a linear system generated by standard nonconforming finite element methods. Algebraic multilevel preconditioners are then constructed for this system based on a triangulation of parallelepipeds into tetrahedral substructures. Explicit estimates of condition numbers and simple computational schemes are established for the constructed preconditioners. Finally, numerical results for the mixed finite element methods are presented to illustrate the present theory.

Key words. Mixed method, nonconforming method, multilevel preconditioner, condition number, second order elliptic problem

AMS(MOS) subject classifications. 65N30, 65N22, 65F10

1. Introduction. Let Ω be a bounded domain in \mathbb{R}^3 , with the polygonal boundary $\partial\Omega$. We consider the elliptic problem

$$(1.1) \quad \begin{aligned} -\nabla \cdot (a\nabla u) &= f && \text{in } \Omega, \\ u &= 0 && \text{on } \partial\Omega, \end{aligned}$$

where $a(x)$ is a uniformly positive definite, bounded, symmetric tensor and $f(x) \in L^2(\Omega)$. Let $(\cdot, \cdot)_S$ denote the $L^2(S)$ inner product (we omit S if $S = \Omega$), and let

$$\begin{aligned} \mathbf{V} &= H(\text{div}; \Omega) = \{\mathbf{v} \in (L^2(\Omega))^3 : \nabla \cdot \mathbf{v} \in L^2(\Omega)\}, \\ W &= L^2(\Omega). \end{aligned}$$

Then (1.1) is formulated in the following mixed form for the pair $(\mathbf{q}, u) \in \mathbf{V} \times W$:

$$(1.2) \quad \begin{aligned} (\nabla \cdot \mathbf{q}, w) &= (f, w), && \forall w \in W, \\ (a^{-1}\mathbf{q}, \mathbf{v}) - (u, \nabla \cdot \mathbf{v}) &= 0, && \forall \mathbf{v} \in \mathbf{V}. \end{aligned}$$

It can be easily seen that (1.1) is equivalent to (1.2) through the relation

$$\mathbf{q} = -a\nabla u.$$

In applications of fluid flow in porous media, $u(x)$ is referred to as pressure and \mathbf{q} as to Darcy velocity vector. It is well known that (1.2) has a unique solution $u(x) \in H_0^1(\Omega) \cap H^2(\Omega)$, and that the following elliptic regularity estimate holds true (cf. [14]):

$$\|u\|_{2,\Omega} \leq c\|f\|_{0,\Omega},$$

* Institute for Scientific Computation and Department of Mathematics, Texas A&M University, 326 Teague Research Center, College Station, TX 77843-3404.

where c is a constant dependent only on Ω and where $\|\cdot\|_{0,\Omega}$ and $\|\cdot\|_{2,\Omega}$ are the $L^2(\Omega)$ and $H^2(\Omega)$ Sobolev norms, respectively defined by

$$\|u\|_{0,\Omega} = \left(\int_{\Omega} u^2 dx \right)^{\frac{1}{2}}, \quad \|u\|_{2,\Omega} = \left(\int_{\Omega} \sum_{|\alpha| \leq m} |\partial^\alpha u|^2 dx \right)^{\frac{1}{2}}.$$

To define a finite element method, we need a partition \mathcal{T}_h of Ω into elements T , say, simplexes, rectangular parallelepipeds, and/or tetrahedra. In \mathcal{T}_h , we also need that adjacent elements completely share their common edge or face; let $\partial\mathcal{T}_h$ denote the set of all *interior* faces e of \mathcal{T}_h .

Let $\tilde{\mathbf{V}}_h \times W_h \subset \mathbf{V} \times W$ denote some standard mixed finite element space for second order elliptic problems defined over \mathcal{T}_h (see, e.g., [5], [6], [11], [21], and [22]). This space is finite dimensional and defined locally on each element $T \in \mathcal{T}_h$, so let $V_h(T) = V_h|_T$ and $W_h(T) = W_h|_T$. Then the mixed finite element method for (1.1) is to find $(\mathbf{q}_h, u_h) \in \tilde{\mathbf{V}}_h \times W_h$:

$$(1.3) \quad \begin{aligned} (\nabla \cdot \mathbf{q}_h, w) &= (f, w), & \forall w \in W_h, \\ (a^{-1}\mathbf{q}_h, \mathbf{v}) - (u_h, \nabla \cdot \mathbf{v}) &= 0, & \forall \mathbf{v} \in \tilde{\mathbf{V}}_h. \end{aligned}$$

The requirement $\tilde{\mathbf{V}}_h \subset \mathbf{V}$ implies that the normal component of the vector \mathbf{q} is continuous across the interelement boundaries $\partial\mathcal{T}_T$. Following [2], we relax this constraint on $\tilde{\mathbf{V}}_h$ by defining $\mathbf{V}_h = \{\mathbf{q} \in (L_h^2(\Omega))^3 : \mathbf{q}|_T \in \tilde{\mathbf{V}}_h(T) \text{ for each } T \in \mathcal{T}_h\}$. In order to enforce the interelement continuity of the normal component of \mathbf{q} we need to introduce the space of the Lagrange multipliers

$$L_h = \left\{ \lambda \in L^2 \left(\bigcup_{e \in \partial\mathcal{T}_h} e \right) : \lambda|_e \in \tilde{\mathbf{V}}_h \cdot \nu_e \text{ for each } e \in \partial\mathcal{T}_h \right\},$$

where ν is the unit normal to e . Also, to establish a relationship between the mixed method and the nonconforming Galerkin method and to construct efficient preconditioners, following [9] and [10] we introduce the projection of the coefficient, i.e., $\alpha_h = P_h a^{-1}$, where P_h is the L^2 -projection onto W_h . Then the hybrid form of the mixed method for (1.1) is to find $(\mathbf{q}_h, u_h, \lambda_h) \in \mathbf{V}_h \times W_h \times L_h$ such that

$$(1.4) \quad \begin{aligned} \sum_{T \in \mathcal{T}_h} (\nabla \cdot \mathbf{q}_h, w)_T &= (f, w), & \forall w \in W_h, \\ (\alpha_h \mathbf{q}_h, \mathbf{v}) - \sum_{T \in \mathcal{T}_h} \left[(u_h, \nabla \cdot \mathbf{v})_T - (\lambda_h, \mathbf{v} \cdot \nu_T)_{\partial T \setminus \partial\Omega} \right] &= 0, & \forall \mathbf{v} \in \mathbf{V}_h, \\ \sum_{T \in \mathcal{T}_h} (\mathbf{q}_h \cdot \nu_T, \mu)_{\partial T \setminus \partial\Omega} &= 0, & \forall \mu \in L_h. \end{aligned}$$

Note that the last equation in (1.4) enforces the continuity requirement mentioned above, so in fact $\mathbf{q}_h \in \tilde{\mathbf{V}}_h$. In [2] and [20], it was shown that the solution to (1.4) can be obtained from a certain modified nonconforming Galerkin method by means of augmenting the latter with bubble functions. Such a relationship has been studied recently for a large variety of mixed finite element spaces [1, 8, 9].

In this paper, following [10] it is shown that the linear system generated by (1.4) can be algebraically condensed to a symmetric, positive definite system for the

Lagrange multiplier λ_h . It is then shown that this linear system can be obtained from the standard nonconforming Galerkin method without using any bubbles.

The main objective of this paper is to construct algebraic multilevel preconditioners for the mixed finite element method. We first use the above equivalence to construct multilevel preconditioners for the linear system for the Lagrange multipliers. Then the mixed method solutions \mathbf{q}_h and u_h are recovered via these multipliers.

The construction of multilevel preconditioners for the mixed methods is inspired by the fundamental work [4], [16], where new systematic representations for preconditioners in the Neumann-Dirichlet domain decomposition methods for conforming finite elements were suggested. The multilevel domain decomposition versions of these methods were outlined in detail in [17, 18]. In addition, the superelement approach used here to estimate condition numbers for two level methods is based on that used in [3, 12, 17, 19].

A detailed description of procedures to construct such preconditioners can be found in [10, 12, 13]. In all these works authors defined partitioning \mathcal{T}_h of the whole domain subdividing it into topological parallelepipeds and splitting each parallelepiped in turn into *six* tetrahedra. The present paper prolongates these results to the case of splitting each topological parallelepiped into *five* tetrahedra. Briefly, the approach used here to construct preconditioners includes two main stages. First, using the idea of partitioning (decomposing) a parallelepiped grid into tetrahedral substructures a three-level preconditioner is constructed with a “7-point” algebraic system on the coarse level, and the condition number of the preconditioned matrix is estimated. The explicit bounds of spectrum of the preconditioned matrix are obtained with help of the superelement approach [12, 17].

On the second stage, we define the preconditioner for the above 7-point algebraic system with one unknown per parallelepiped and show that this preconditioner is equivalent to the standard finite element approximation of the equation (1.1) with modified coefficient tensor $\tilde{a}(x)$. To solve this problem we can use any well known technique. Namely, in this paper we use multilevel domain decomposition method [16, 17] to solve this auxiliary coarse level problem. The constructed preconditioners are spectrally equivalent to the original stiffness matrix and their arithmetic cost does not depend on the mesh size h and jump of the coefficient $a(x)$.

Explicit estimates of condition numbers are obtained for these multilevel preconditioners. A computational scheme for implementing these preconditioners is also considered, and a three-step preconditioned conjugate gradient method using the present technique is described as well.

In this paper the case where $a(x)$ is a scalar tensor and Ω is a regular parallelepiped is analyzed in detail for the three-level and multilevel preconditioners.

The rest of the paper is organized as follows. In the next section we consider an elimination procedure for (1.4). Then, in section 3 we develop three-level preconditioner for the resulting linear system. Development of three-level preconditioner to multilevel one and the multilevel domain decomposition method for solving coarse level problem is described in section 4. Finally, in section 5 extensive numerical results are presented for both nonconforming and mixed methods on logical parallelepipeds to illustrate the present theory.

2. The mixed finite element method. We now consider the most useful partition \mathcal{T}_h of Ω into tetrahedra. The lowest-order Raviart-Thomas-Nedelec space

[22, 21] defined over $T \in \mathcal{T}_h$ is given by

$$\begin{aligned} \mathbf{V}_h(T) &= (P_0(T))^3 \oplus ((x, y, z)P_0(T)), \\ W_h(T) &= P_0(T), \\ L_h(e) &= P_0(e), \end{aligned}$$

where $P_i(T)$ is the restriction of the set of all polynomials of total degree not bigger than $i \geq 0$ to the set $T \in \mathcal{T}_h$. For each T in \mathcal{T}_h , let $\bar{f}_T = \frac{1}{|T|}(f, 1)_T$, where $|T|$ denotes the volume of T . Also, set $\alpha_h = (\alpha_{ij})$ and $\mathbf{q}_h|_T = (\mathbf{q}_{T1}, \mathbf{q}_{T2}, \mathbf{q}_{T3}) = (r_T^1 + t_T x, r_T^2 + t_T y, r_T^3 + t_T z)$. Then, by the first equation of (1.4) it follows that

$$(2.1) \quad t_T = \bar{f}_T/3.$$

Now, take $\mathbf{v} = (1, 0, 0)$ in T and $\mathbf{v} = 0$ elsewhere, $\mathbf{v} = (0, 1, 0)$ in T and $\mathbf{v} = 0$ elsewhere, and $\mathbf{v} = (0, 0, 1)$ in T and $\mathbf{v} = 0$ elsewhere, respectively, in the second equation of (1.4) to obtain

$$(2.2) \quad \left(\sum_{i=1}^3 \alpha_{ji} \mathbf{q}_{Ti}, 1 \right)_T + \sum_{i=1}^4 |e_T^i| \nu_T^{i(j)} \lambda_h|_{e_T^i} = 0, \quad j = 1, 2, 3,$$

where $|e_T^i|$ is the area of the face e_T^i , and $\nu_T^i = (\nu_T^{i(1)}, \nu_T^{i(2)}, \nu_T^{i(3)})$. Let $\beta^T = (\beta_{ij}^T) = ((\alpha_{ij}, 1)_T)^{-1}$. Then (2.2) can be solved for r_T^j :

$$(2.3) \quad \begin{aligned} r_T^j &= - \sum_{i=1}^4 |e_T^i| \left(\beta_{j1}^T \nu_T^{i(1)} + \beta_{j2}^T \nu_T^{i(2)} + \beta_{j3}^T \nu_T^{i(3)} \right) \lambda_h|_{e_T^i} - \\ &\quad - \frac{\bar{f}_T}{3} \left(\sum_{i=1}^3 \beta_{ji}^T (\alpha_{i1}x + \alpha_{i2}y + \alpha_{i3}z), 1 \right)_T, \quad j = 1, 2, 3. \end{aligned}$$

Let the basis in L_h be chosen as usual. Namely, take $\mu = 1$ on one face and $\mu = 0$ elsewhere in the last equation of (1.4). Then, apply (2.1) and (2.3) to see that the contributions of the tetrahedron T to the stiffness matrix and the right-hand side are

$$A_{ij}^T = \bar{v}_T^i \beta^T \bar{v}_T^j, \quad F_i^T = - \frac{(J_T^f, \bar{v}_T^i)_T}{|T|} + (J_T^f, \nu_T^i)_{e_T^i}, \quad T \in \mathcal{T}_h,$$

where $\bar{v}_T^i = |e_T^i| \nu_T^i$ and $J_T^f = \bar{f}_T(x, y, z)/3$. Hence we obtain the system for λ_h :

$$(2.4) \quad A\lambda = \mathbf{F}.$$

After the computation of λ_h , we can recover \mathbf{q}_h via (2.1) and (2.3). Also, if u_h is required, it follows from the second equation of (1.4) that

$$u_T = \frac{1}{3|T|} \left((\alpha \mathbf{q}_h, (x, y, z))_T + \sum_{i=1}^4 \lambda_h|_{e_T^i} ((x, y, z), \nu_T^i)_{e_T^i} \right), \quad T \in \mathcal{T}_h.$$

The above result is summarized in the following lemma.

LEMMA 2.1. *Let*

$$M_h(\chi, \mu) = \sum_{T \in \mathcal{T}_h} (\chi, \nu_T)_{\partial T} \beta^T (\mu, \nu_T)_{\partial T}, \quad \chi, \mu \in L_h,$$

$$F_h(\mu) = - \sum_{T \in \mathcal{T}_h} \frac{1}{|T|} (J^f, 1)_T \cdot (\mu, \nu_T)_{\partial T} + \sum_{T \in \mathcal{T}_h} (\mu J^f, \nu_T)_{\partial T}, \quad \mu \in L_h,$$

where J^f is such that $J^f|_T = J_T^f$. Then $\lambda_h \in \mathcal{L}_h$ satisfies

$$(2.5) \quad M_h(\lambda_h, \mu) = F_h(\mu), \quad \forall \mu \in \mathcal{L}_h,$$

where

$$\mathcal{L}_h = \{\mu \in L_h : \mu|_e = 0 \text{ for each } e \subset \partial\Omega\}.$$

Note that there are at most seven nonzero entries per row in the stiffness matrix A . Also, it is easy to see that the matrix A is a symmetric and positive definite matrix; moreover, if the angles of every T in \mathcal{T}_h are not bigger than $\pi/2$, then it is an M -matrix. Finally, (2.4) corresponds to the P_1 nonconforming finite element method system, as described below. This equivalence is used to construct our multilevel preconditioners later.

Let

$$(2.6) \quad \mathcal{N}_h = \{v \in L^2(\Omega) : v|_T \in P_1(T), \forall T \in \mathcal{T}_h; v \text{ is continuous at the barycenters of interior faces and vanishes at the barycenters of faces on } \partial\Omega\}.$$

PROPOSITION 2.2. *Let $f_h = P_h f$. Then (2.4) corresponds to the linear system produced by the problem: find $\psi_h \in \mathcal{N}_h$ such that*

$$(2.7) \quad a_h(\psi_h, \varphi) = (f_h, \varphi), \quad \forall \varphi \in \mathcal{N}_h,$$

where $a_h(\psi_h, \varphi) = \sum_{T \in \mathcal{T}_h} (\alpha_h^{-1} \nabla \psi_h, \nabla \varphi)_T$.

Proof. From the definition of the basis $\{\psi_i^h\}$ of \mathcal{N}_h , for each $T \in \mathcal{T}_h$ we have

$$\psi_i^h|_T = \frac{1}{|T|} \bar{\nu}_T^i \cdot ((x, y, z) - p_l), \quad i \neq l,$$

for some barycenter p_l . Then, we see that

$$(\alpha_h^{-1} \nabla \psi_i^h, \nabla \psi_j^h)_T = \bar{\nu}_T^i \beta^T \bar{\nu}_T^j,$$

which is a_{ij}^T . Also, note that for any linear functions ψ and ϕ on a tetrahedron $T \in \mathcal{T}_h$

$$(2.8) \quad (\psi, \phi)_T = \frac{1}{4} |T| \sum_{i=1}^4 \psi(p_i) \phi(p_i),$$

where the p_i 's are the barycenters of the faces of T , so that

$$\begin{aligned} F_i^T &= -\frac{(J_T^f, \bar{\nu}_T^i)_T}{|T|} + (J_T^f, \nu_T^i)_{e_T^i} \\ &= -\frac{\bar{f}_T}{3} (1, \psi_i^h)_T + \frac{|T| \bar{f}_T}{3 |e_T^i|} (\psi_i^h, 1)_{e_T^i} \\ &= \bar{f}_T (1, \psi_i^h)_T, \end{aligned}$$

which is $(f_h, \psi_i^h)_T$. \square

3. Three level preconditioner over a cube. In this section we consider multilevel preconditioners for (2.4) based on partitioning regular parallelepipeds into tetrahedral substructures, following the ideas in [12] and [13]. Here we treat the case where Ω is a unit cube and $a(x)$ is a scalar tensor.

Our goal is to introduce an algebraic formulation of the approximate problem using a type of static condensation that eliminates some of the unknowns. In this way we can reduce substantially the size of the problem. For this approach we need a special partitioning of the domain into tetrahedra that have some regularity and preserve the simplicity of the algebraic problem.

Let $\mathcal{C}_h = \{C^{(i,j,k)}\}$ be a partition of Ω into uniform cubes with the length $h = 1/n$, where (x_i, y_j, z_k) is the right back upper corner of the cube $C^{(i,j,k)}$. Next, each cube $C^{(i,j,k)}$ is divided into 5 tetrahedra as shown in Figure 1 and denote this partitioning of Ω into tetrahedra by \mathcal{T}_h .

Let $W_{c,h}$ be the space of piecewise constants associated with \mathcal{C}_h , and $P_{c,h}$ be the L^2 -projection onto $W_{c,h}$. To define our preconditioner, we introduce $\alpha_h = P_{c,h}a^{-1}$ in the hybrid form (1.4) instead of $\alpha_h = P_h a^{-1}$. Obviously, Lemma 2.1 and Proposition 2.2 are still valid for this modification since \mathcal{T}_h is a refinement of \mathcal{C}_h . With this modification, α_h^{-1} is a constant on each cube. For notational convenience, we drop the subscript h and simply write $\alpha_h^{-1} = a_c \text{diag}\{1, 1, 1\}$.

Let \mathcal{N}_h be the nonconforming finite element space associated with \mathcal{T}_h as defined in (2.6), and let its dimension be N . All the unknowns on the faces of $\partial\Omega$ are excluded. For this reason $N = 10n^3 - 6n^2$. For any function $v_h \in \mathcal{N}_h$, we denote by $\mathbf{v} \in \mathbb{R}^N$ the corresponding vector of its degrees of freedom. Introduce the inner product

$$(3.1) \quad (\mathbf{u}, \mathbf{v})_N = h^3 \sum_{p_i \in \partial\mathcal{T}_h} u_h(p_i)v_h(p_i), \quad \forall u_h, v_h \in \mathcal{N}_h,$$

where the p_i 's are the barycenters of the interior faces. By (2.8) the norm induced by (3.1) is equivalent to the L^2 -norm on Ω .

For each cube $C = C^{(i,j,k)} \in \mathcal{C}_h$, denote by \mathcal{N}_h^C the subspace of the restriction of the functions in \mathcal{N}_h onto C . For each $\mathbf{v} \in \mathcal{N}_h^C$, we indicate by \mathbf{v}_c its corresponding vector. The dimension of \mathcal{N}_h^C is denoted by N^C . Obviously, for a cube without faces on $\partial\Omega$ its dimension is 16, i.e., $N^C = 16$.

The local stiffness matrix A^C on cube $C \in \mathcal{C}_h$ is given by

$$(3.2) \quad (A^C \mathbf{u}_c, \mathbf{v}_c)_{N^C} = \sum_{T \subset C} (\alpha_h \nabla u_h, \nabla v_h)_T, \quad \forall u_h, v_h \in \mathcal{N}_h^C.$$

Then the global stiffness matrix is determined by assembling the local stiffness matrices:

$$(3.3) \quad (A\mathbf{u}, \mathbf{v})_N = \sum_{C \in \mathcal{C}_h} (A^C \mathbf{u}_c, \mathbf{v}_c)_{N^C}, \quad \forall \mathbf{u}, \mathbf{v} \in \mathbb{R}^N.$$

Now we consider a cube C that has no face on the boundary $\partial\Omega$ and enumerate the faces s_j , $j = 1, \dots, 16$ of the tetrahedra in this cube as shown in Figure 2. Then the local stiffness matrix of this prism has the following form:

$$A^C = \frac{3h}{2} a_c \begin{bmatrix} 9/2 & -1/2 & -1/2 & -1/2 & -1 & -1 & -1 & 0 & 0 & 0 & 0 & 0 & 0 & 0 & 0 & 0 \\ -1/2 & 9/2 & -1/2 & -1/2 & 0 & 0 & 0 & -1 & -1 & -1 & 0 & 0 & 0 & 0 & 0 & 0 \\ -1/2 & -1/2 & 9/2 & -1/2 & 0 & 0 & 0 & 0 & 0 & 0 & -1 & -1 & -1 & 0 & 0 & 0 \\ -1/2 & -1/2 & -1/2 & 9/2 & 0 & 0 & 0 & 0 & 0 & 0 & 0 & 0 & 0 & -1 & -1 & -1 \\ \hline -1 & 0 & 0 & 0 & 1 & & & & & & & & & & & \\ -1 & 0 & 0 & 0 & & 1 & & & & & & & & & & \\ -1 & 0 & 0 & 0 & & & 1 & & & & & & & & & \\ 0 & -1 & 0 & 0 & & & & 1 & & & & & & & & \\ 0 & -1 & 0 & 0 & & & & & 1 & & & & & & & \\ 0 & -1 & 0 & 0 & & & & & & 1 & & & & & & \\ 0 & 0 & -1 & 0 & & & & & & & 1 & & & & & \\ 0 & 0 & -1 & 0 & & & & & & & & 1 & & & & \\ 0 & 0 & -1 & 0 & & & & & & & & & 1 & & & \\ 0 & 0 & 0 & -1 & & & & & & & & & & 1 & & \\ 0 & 0 & 0 & -1 & & & & & & & & & & & 1 & \\ 0 & 0 & 0 & -1 & & & & & & & & & & & & 1 \\ 0 & 0 & 0 & -1 & & & & & & & & & & & & 1 \end{bmatrix},$$

which we write as

$$(3.4) \quad A^C = \frac{3h}{2} a_c \begin{bmatrix} A_{11,c} & A_{12,c} \\ A_{21,c} & A_{22,c} \end{bmatrix},$$

where

$$(3.5) \quad A_{11,c} = 3 I_{11,c} + \frac{1}{2} \begin{bmatrix} 3 & -1 & -1 & -1 \\ -1 & 3 & -1 & -1 \\ -1 & -1 & 3 & -1 \\ -1 & -1 & -1 & 3 \end{bmatrix}, \quad A_{22,c} = I_{22,c}.$$

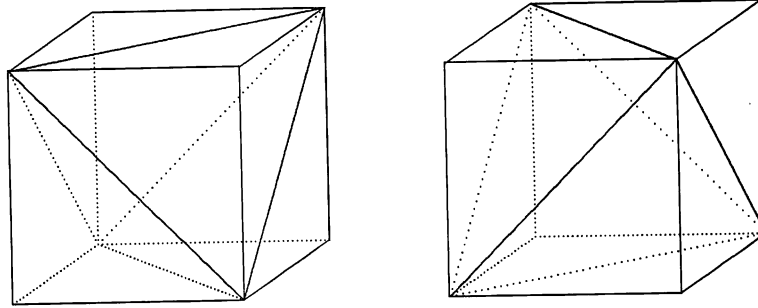

FIGURE 1. Partition of cube into tetrahedra.

Along with matrix A^C we also introduce the matrix B^C as

$$(3.6) \quad B^C = \frac{3h}{2} a_c \begin{bmatrix} B_{11,c} & A_{12,c} \\ A_{21,c} & A_{22,c} \end{bmatrix},$$

where

$$B_{11,c} = 3 I_{11,c} + 2 \begin{bmatrix} 3 & -1 & -1 & -1 \\ -1 & 1 & 0 & 0 \\ -1 & 0 & 1 & 0 \\ -1 & 0 & 0 & 1 \end{bmatrix},$$

PROPOSITION 3.1. *It holds that $\ker A^C = \ker B^C$.*

Proof. It is easy to see from the definitions of A^C and B^C that $\ker A^C = \ker B^C = \{\mathbf{v} = (v_1, v_2, \dots, v_{16})^T \in \mathbb{R}^{16} : v_i = v_1, i = 2, \dots, 16\}$. \square

Remark. If the cube $C \in \mathcal{C}_h$ has a face on $\partial\Omega$, then the matrix A^C does not have the rows and columns which correspond to the nodes on that face; the blocks $A_{11,c}$ and $B_{11,c}$ are the same as in the previous case and the modification of $A_{22,c}$ is obvious.

We now define the $N \times N$ matrix B by the following equality:

$$(3.7) \quad (B\mathbf{u}, \mathbf{v})_N = \sum_{C \in \mathcal{C}_h} (B^C \mathbf{u}_c, \mathbf{v}_c)_{NC}, \quad \forall \mathbf{u}, \mathbf{v} \in \mathbb{R}^N.$$

Since the matrix B is used for preconditioning the original problem (2.4), it is important to estimate the condition number of $B^{-1}A$.

LEMMA 3.2. *Let μ_c satisfy the equality*

$$(3.8) \quad A^C \mathbf{u}_c = \mu_c B^C \mathbf{u}_c, \quad C \in \mathcal{C}_h.$$

Then we have

$$(3.9) \quad \max_{(B\mathbf{u}, \mathbf{u})_N \neq 0} \frac{(A\mathbf{u}, \mathbf{u})_N}{(B\mathbf{u}, \mathbf{u})_N} \leq \max_{C \in \mathcal{C}_h} \mu_c \quad \text{and} \quad \min_{(B\mathbf{u}, \mathbf{u})_N \neq 0} \frac{(A\mathbf{u}, \mathbf{u})_N}{(B\mathbf{u}, \mathbf{u})_N} \geq \min_{C \in \mathcal{C}_h} \mu_c.$$

Proof. For each $C \in \mathcal{C}_h$, it follows from (3.8) that

$$(A^C \mathbf{u}_c, \mathbf{u}_c)_{NC} = \mu_c (B^C \mathbf{u}_c, \mathbf{u}_c)_{NC}.$$

It then follows from the fact that all local stiffness matrices are nonnegative that

$$\begin{aligned} \sum_{C \in \mathcal{C}_h} (A^C \mathbf{u}_c, \mathbf{u}_c)_{NC} &= \sum_{C \in \mathcal{C}_h} \mu_c (B^C \mathbf{u}_c, \mathbf{u}_c)_{NC} \\ &\leq \max_{C \in \mathcal{C}_h} \mu_c \sum_{C \in \mathcal{C}_h} (B^C \mathbf{u}_c, \mathbf{u}_c)_{NC}. \end{aligned}$$

Hence from the definitions of A and B , we see that

$$(A\mathbf{u}, \mathbf{u})_N \leq \max_{C \in \mathcal{C}_h} \mu_c (B\mathbf{u}, \mathbf{u})_N.$$

Consequently, the first inequality in (3.9) is true. The same argument can be used to show the second inequality. \square

From Lemma 3.2, we see that, to estimate the condition number of $B^{-1}A$, it suffices to consider the local problems (3.8). Using a superelement analysis [16, 19], to estimate $\max_{C \in \mathcal{C}_h} \mu_c$ and $\min_{C \in \mathcal{C}_h} \mu_c$, it suffices to treat the worst case where the cube $C \in \mathcal{C}_h$ has no face on the boundary $\partial\Omega$. From (3.4) and (3.6), a direct calculation shows that the eigenvalues μ_c are within the interval $[1/4, 1]$.

Then the inequalities (3.9) yield:

PROPOSITION 3.3. *The eigenvalues of problem*

$$(3.10) \quad A\mathbf{u} = \mu B\mathbf{u}$$

belong to the interval $[1/4, 1]$ and the condition number is thus estimated by

$$\text{cond}(B^{-1}A) \leq 4.$$

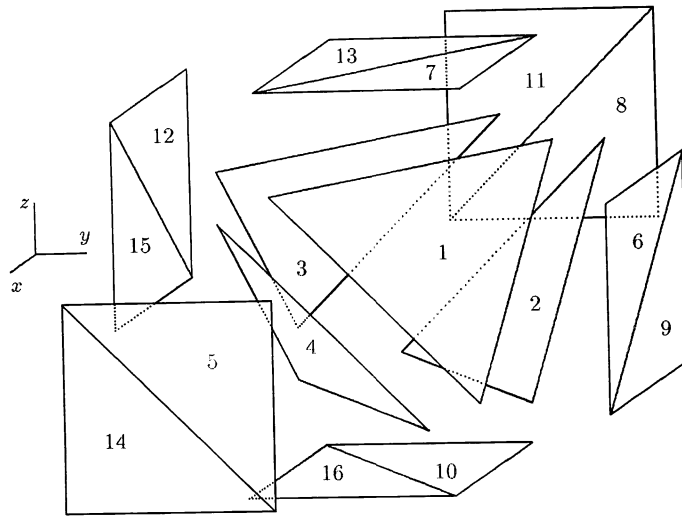

(a) Cube of type I

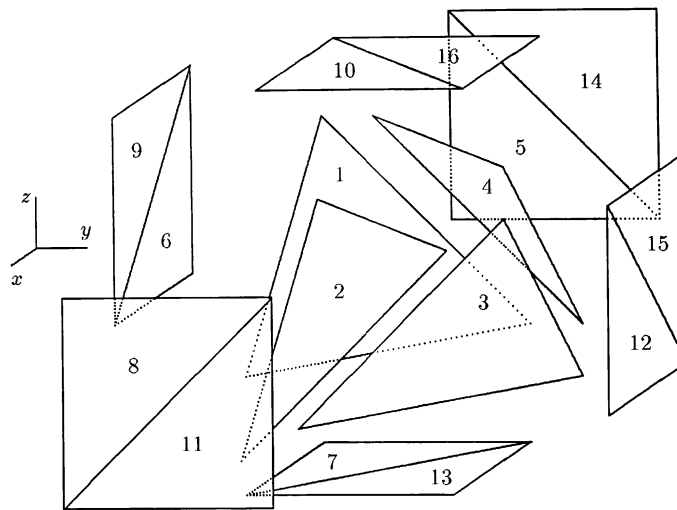

(b) Cube of type II

FIGURE 2. Local enumeration of faces in cubes.

We stress that the condition number of the matrix $B^{-1}A$ is bounded by a constant independent of the step size of the mesh h and the jump of the coefficient $a(x)$. Since we introduced a two level subdivision, the matrix B can be referred to as a two level preconditioner.

Then, in this section we propose a modification of the matrix B and consider its properties. Toward that end, we divide all unknowns in the system into three groups:

1. The first group consists of the one unknown per cube corresponding to the 1st faces of the tetrahedra that are internal for each cube $C \in \mathcal{C}_h$ (see Figure 2, faces 1).
2. The second group consists of all unknowns corresponding to faces of the cubes in the partition \mathcal{C}_h , excluding the faces on $\partial\Omega$ (Figure 2, faces 5, 6, ..., 16).

3. The third group consists of the unknowns corresponding to the faces of the tetrahedra that are internal for each cube and which are not in the 1st group (these are unknowns on faces 2, 3 and 4 on Figure 2).

This splitting of the space \mathbb{R}^N induces the presentation of the vectors: $\mathbf{v}^T = (\mathbf{v}_1^T, \mathbf{v}_2^T)$, where $\mathbf{v}_1 \in \mathbb{R}^{N_1}$ and $\mathbf{v}_2 \in \mathbb{R}^{N_2}$, where \mathbf{v}_2 corresponds to the unknowns of the 3-rd group. Obviously, $N_2 = 3n^3$ and $N_1 = N - 3n^3$. Then the matrix B can be presented in the following block form:

$$(3.11) \quad B = \begin{bmatrix} B_{11} & B_{12} \\ B_{21} & B_{22} \end{bmatrix}, \quad \dim B_{11} = N_1.$$

Denote now by $\hat{B}_{11} = B_{11} - B_{12}B_{22}^{-1}B_{21}$ the Schur complement of B obtained by elimination of the vector \mathbf{v}_2 . Then $B_{11} = \hat{B}_{11} + B_{12}B_{22}^{-1}B_{21}$, so the matrix B has the form

$$(3.12) \quad B = \begin{bmatrix} \hat{B}_{11} + B_{12}B_{22}^{-1}B_{21} & B_{12} \\ B_{21} & B_{22} \end{bmatrix}.$$

Note that for each cube $C \in \mathcal{C}_h$ the unknowns of the 3rd group (unknowns on the faces 2, 3 and 4 in local enumeration, see Figure 2) are connected only with the unknowns of the 1st and 2nd groups and therefore the matrix B_{22} is diagonal and can be inverted locally (cube by cube). Thus, matrix \hat{B}_{11} is easily computable. The proposed modification of the matrix B from (3.12) is of the form

$$\tilde{B} = \begin{bmatrix} \tilde{B}_0 + B_{12}B_{22}^{-1}B_{21} & B_{12} \\ B_{21} & B_{22} \end{bmatrix},$$

where \tilde{B}_0 is to be defined later.

Consider now the restriction of the matrix B on a single cube

$$B^C = \begin{bmatrix} B_{11,c} & B_{12,c} \\ B_{21,c} & B_{22,c} \end{bmatrix},$$

and define the Schur complement on a cube by $\hat{B}_{11,c} = B_{11,c} - B_{12,c}B_{22,c}^{-1}B_{21,c}$. In the local enumeration introduced on Figure 2 the matrix $\hat{B}_{11,c}$ has the form

$$\hat{B}_{11,c} = \frac{3h}{2}a_c \left[\begin{array}{c|cccccccccccccc} 33/5 & -1 & -1 & -1 & -2/5 & -2/5 & -2/5 & -2/5 & -2/5 & -2/5 & -2/5 & -2/5 & -2/5 & -2/5 \\ -1 & 1 & & & & & & & & & & & & & \\ -1 & & 1 & & & & & & & & & & & & \\ -1 & & & 1 & & & & & & & & & & & \\ -2/5 & & & & 4/5 & -1/5 & -1/5 & & & & & & & & \\ -2/5 & & & & -1/5 & 4/5 & -1/5 & & & & & & & & \\ -2/5 & & & & -1/5 & -1/5 & 4/5 & & & & & & & & \\ -2/5 & & & & & & & 4/5 & -1/5 & -1/5 & & & & & \\ -2/5 & & & & & & & -1/5 & 4/5 & -1/5 & & & & & \\ -2/5 & & & & & & & -1/5 & -1/5 & 4/5 & & & & & \\ -2/5 & & & & & & & & & & 4/5 & -1/5 & -1/5 & & \\ -2/5 & & & & & & & & & & -1/5 & 4/5 & -1/5 & & \\ -2/5 & & & & & & & & & & -1/5 & -1/5 & 4/5 & & \end{array} \right]$$

Remark. If the cube $C \in \mathcal{C}_h$ has a face on $\partial\Omega$, then the matrix $\hat{B}_{11,c}$ does not have the rows and columns which correspond to the nodes on that face.

Following [12], we introduce on each cube a modification of the matrices $\hat{B}_{11,c}$ in the form:

$$\tilde{B}_{11,c} = \frac{3h}{2} a_c \begin{bmatrix} 12 & -1 & -1 & -1 & -1 & -1 & -1 & -1 & -1 & -1 & -1 & -1 & -1 \\ -1 & 1 & & & & & & & & & & & \\ -1 & & 1 & & & & & & & & & & \\ -1 & & & 1 & & & & & & & & & \\ -1 & & & & 1 & & & & & & & & \\ -1 & & & & & 1 & & & & & & & \\ -1 & & & & & & 1 & & & & & & \\ -1 & & & & & & & 1 & & & & & \\ -1 & & & & & & & & 1 & & & & \\ -1 & & & & & & & & & 1 & & & \\ -1 & & & & & & & & & & 1 & & \\ -1 & & & & & & & & & & & 1 & \\ -1 & & & & & & & & & & & & 1 \\ -1 & & & & & & & & & & & & & 1 \end{bmatrix}$$

PROPOSITION 3.4. *The matrices $\hat{B}_{11,c}$ and $\tilde{B}_{11,c}$ have the same kernel, i.e., $\ker \hat{B}_{11,c} = \ker \tilde{B}_{11,c}$.*

Proof. It can be easily checked that $\ker \hat{B}_{11,c} = \ker \tilde{B}_{11,c} = \{\mathbf{v} = (v_1, v_2, \dots, v_{13})^T \in \mathbb{R}^{13} : v_i = v_1, i = 2, \dots, 13\}$. \square

We now consider the eigenvalue problem

$$(3.13) \quad \hat{B}_{11,c} \mathbf{u} = \mu \tilde{B}_{11,c} \mathbf{u}, \quad \mathbf{u} \in \mathbb{R}^{13}.$$

It is easy to check the proposition

PROPOSITION 3.5. *The eigenvalues of problem (3.13) belong to the interval $[2/5, 1]$.*

Now defining a new matrix on each cube:

$$(3.14) \quad \tilde{B}^C = \begin{bmatrix} \tilde{B}_{11,c} + B_{12,c} B_{22,c}^{-1} B_{21,c} & B_{12,c} \\ B_{21,c} & B_{22,c} \end{bmatrix}.$$

we define the symmetric positive-definite $N_1 \times N_1$ matrix \tilde{B}_0 by

$$(\tilde{B}_0 \mathbf{u}_1, \mathbf{v}_1) = \sum_{C \in \mathcal{C}_h} (\tilde{B}_{11,c} \mathbf{u}_{1,c}, \mathbf{v}_{1,c}),$$

where $\mathbf{v}_1, \mathbf{u}_1 \in \mathbb{R}^{N_1}$, and $\mathbf{u}_{1,c}$ and $\mathbf{v}_{1,c}$ are their respective restrictions on the cube C . As in (3.12), we introduce the matrix

$$(3.15) \quad \tilde{B} = \begin{bmatrix} \tilde{B}_0 + B_{12} B_{22}^{-1} B_{21} & B_{12} \\ B_{21} & B_{22} \end{bmatrix}.$$

Using Propositions 3.3 and 3.5, and the same proof as in Proposition 3.2 we have the following theorem.

THEOREM 3.6. *The matrix \tilde{B} defined in (3.15) is spectrally equivalent to the matrix A , i.e.,*

$$\mu_* \tilde{B} \leq A \leq \mu^* \tilde{B},$$

where $\mu_* = 1/10$ and $\mu^* = 1$. Moreover,

$$(3.16) \quad \text{cond}(\tilde{B}^{-1} A) \leq \bar{\mu} \equiv \mu^* / \mu_* \leq 10.$$

Instead of the matrix B in the form (3.12) we take the matrix \tilde{B} from (3.15) as a preconditioner for the matrix A . As we noted earlier, the matrix B_{22} is block-diagonal and can be inverted locally on cubes. So we concentrate on the linear system

$$(3.17) \quad \tilde{B}_0 \mathbf{u} = \mathbf{G}.$$

In terms of the group partitioning in section 3, the matrix \tilde{B}_0 has the block form

$$(3.18) \quad \tilde{B}_0 = \begin{bmatrix} C_{11} & C_{12} \\ C_{21} & C_{22} \end{bmatrix},$$

where the block C_{22} corresponds to the nodes from the second group, which are on the faces of tetrahedra perpendicular to the coordinate axes. From the definition of \tilde{B}_0 , it can be seen that the matrix C_{22} is diagonal. In the above partitioning, we present \mathbf{u} and \mathbf{G} in (3.17) in the form

$$(3.19) \quad \mathbf{u} = \begin{bmatrix} \mathbf{u}_1 \\ \mathbf{u}_2 \end{bmatrix}, \quad \mathbf{G} = \begin{bmatrix} \mathbf{G}_1 \\ \mathbf{G}_2 \end{bmatrix}.$$

Then, after elimination of the second group of unknowns $\mathbf{u}_2 = C_{22}^{-1}(\mathbf{G}_2 - C_{21}\mathbf{u}_1)$, we get the system of linear equations

$$(3.20) \quad (C_{11} - C_{12}C_{22}^{-1}C_{21})\mathbf{u}_1 = \mathbf{G}_1 - C_{12}C_{22}^{-1}\mathbf{G}_2 \equiv \tilde{\mathbf{G}}_1,$$

where the vector \mathbf{u}_1 and the block C_{11} correspond to the unknowns from the first group, which have only one unknown per each cube. The dimension of vectors \mathbf{u}_1 and \mathbf{G}_1 is obviously equal to

$$M = \dim(\mathbf{u}_1) = n^3.$$

Thus, defining as above Schur complement of matrix \tilde{B}_0 by $\hat{C}_{11} = C_{11} - C_{12}C_{22}^{-1}C_{21}$ matrix \tilde{B} can be presented in the form

$$(3.21) \quad \tilde{B} = \begin{bmatrix} \left[\begin{array}{cc} \hat{C}_{11} + C_{12}C_{22}^{-1}C_{21} & C_{12} \\ C_{21} & C_{22} \end{array} \right] + B_{12}B_{22}^{-1}B_{21} & B_{12} \\ & B_{22} \end{bmatrix},$$

where matrices B_{22} and C_{22} are diagonal and can be inverted locally cube-by-cube. Again, we have to stress that the condition number of the matrix $\tilde{B}^{-1}A$ is bounded by the constant independent of the step size of the mesh h and the jump of the coefficient $a(x)$. The matrix \tilde{B} can be referred to as a three-level preconditioner.

By making straightforward calculations it can be shown that the Schur complement \hat{C}_{11} is "7-point-scheme" matrix. Introducing for each cube $C^{(i,j,k)}$ the coefficients

$$(3.22) \quad \begin{aligned} K_1^{(i,j,k)} &= \left(\frac{3h}{2}\right)^2 \frac{a^{(i,j,k)} \cdot a^{(i+1,j,k)}}{a^{(i,j,k)} + a^{(i+1,j,k)}}, \\ K_2^{(i,j,k)} &= \left(\frac{3h}{2}\right)^2 \frac{a^{(i,j,k)} \cdot a^{(i,j+1,k)}}{a^{(i,j,k)} + a^{(i,j+1,k)}}, \\ K_3^{(i,j,k)} &= \left(\frac{3h}{2}\right)^2 \frac{a^{(i,j,k)} \cdot a^{(i,j,k+1)}}{a^{(i,j,k)} + a^{(i,j,k+1)}}, \end{aligned}$$

matrix \hat{C}_{11} can be schematically represented in the following form for $C^{(i,j,k)} \cap \partial\Omega = \emptyset$

$$\begin{array}{c}
[-K_3^{(i,j,k)}] \quad [-K_1^{(i-1,j,k)}] \\
| \quad \diagdown \\
[-K_2^{(i,j-1,k)}] \text{ --- } \left[\begin{array}{c} K_1^{(i-1,j,k)} + K_2^{(i,j-1,k)} + K_3^{(i,j,k-1)} + \\ + K_1^{(i,j,k)} + K_2^{(i,j,k)} + K_3^{(i,j,k)} \end{array} \right] \text{ --- } [-K_2^{(i,j,k)}] \\
\diagup \quad | \\
[-K_1^{(i,j,k)}] \quad [-K_3^{(i,j,k-1)}]
\end{array}$$

If $C^{(i,j,k)} \cap \partial\Omega \neq \emptyset$ then the previous scheme is modified in a natural way, for example for $i = 1, j, k \neq 1, n$, for unknown in cube $C^{(1,j,k)}$ we have the scheme

$$\begin{array}{c}
[-K_3^{(1,j,k)}] \\
| \\
[-K_2^{(1,j-1,k)}] \text{ --- } \left[\begin{array}{c} (\frac{3h}{2}) 2 a^{(1,j,k)} + K_2^{(1,j-1,k)} + K_3^{(1,j,k-1)} + \\ + K_1^{(1,j,k)} + K_2^{(1,j,k)} + K_3^{(1,j,k)} \end{array} \right] \text{ --- } [-K_2^{(1,j,k)}] \\
\diagup \quad | \\
[-K_1^{(1,j,k)}] \quad [-K_3^{(1,j,k-1)}]
\end{array}$$

In the next section we consider the solution techniques for problem (3.20) with the matrix \hat{C}_{11} :

$$(3.23) \quad \hat{C}_{11} \mathbf{v} = \mathbf{g}.$$

4. Multilevel preconditioner over a cube. While the preconditioner \tilde{B} has good properties, it is still not economical to invert it because the entries of the matrix \hat{C}_{11} depend on jump of the coefficients. In this section we propose a modification of the matrix \hat{C}_{11} provided additional assumptions on the behaviour of the function $a(x)$ and show that for that modification we can use any well known multilevel procedure.

Assumption (A1): Suppose that unit cube Ω can be represented as a union of a certain number m of pairwise disjoint cubes $G_i, i = 1, \dots, m$ with the size of edge H ($H > 2h$) in such a way that in each cube G_i the function $a(x)$ is a positive constant.

In other words, we set $\bar{\Omega} = \bigcup_{i=1}^m \bar{G}_i$ and $a(x) = \text{const}_i > 0, x \in G_i, i = 1, \dots, m$.

For each cube $C^{(i,j,k)} \in \mathcal{T}_C$ consider the following submatrices

$$(4.1) \quad S_l^{(i,j,k)} = K_l^{(i,j,k)} \begin{bmatrix} 1 & -1 \\ -1 & 1 \end{bmatrix}, \quad l = 1, 2, 3, \quad i, j, k = 2, \dots, n-1,$$

with obvious modifications for boundary cubes,

$$\begin{aligned}
S_1^{(1,j,k)} &= K_1^{(1,j,k)} \begin{bmatrix} 1 & -1 \\ -1 & 1 \end{bmatrix} + \left(\frac{3h}{2}\right) \begin{bmatrix} 2a^{(1,j,k)} & 0 \\ 0 & 0 \end{bmatrix}, \\
S_1^{(n-1,j,k)} &= K_1^{(n-1,j,k)} \begin{bmatrix} 1 & -1 \\ -1 & 1 \end{bmatrix} + \left(\frac{3h}{2}\right) \begin{bmatrix} 0 & 0 \\ 0 & 2a^{(n,j,k)} \end{bmatrix},
\end{aligned} \quad j, k = 1, \dots, n,$$

$$\begin{aligned}
S_2^{(i,1,k)} &= K_2^{(i,1,k)} \begin{bmatrix} 1 & -1 \\ -1 & 1 \end{bmatrix} + \left(\frac{3h}{2}\right) \begin{bmatrix} 2a^{(i,1,k)} & 0 \\ 0 & 0 \end{bmatrix}, \\
S_2^{(i,n-1,k)} &= K_2^{(i,n-1,k)} \begin{bmatrix} 1 & -1 \\ -1 & 1 \end{bmatrix} + \left(\frac{3h}{2}\right) \begin{bmatrix} 0 & 0 \\ 0 & 2a^{(i,n,k)} \end{bmatrix}, \\
S_3^{(i,j,1)} &= K_3^{(i,j,1)} \begin{bmatrix} 1 & -1 \\ -1 & 1 \end{bmatrix} + \left(\frac{3h}{2}\right) \begin{bmatrix} 2a^{(i,j,1)} & 0 \\ 0 & 0 \end{bmatrix}, \\
S_3^{(i,j,n-1)} &= K_3^{(i,j,n-1)} \begin{bmatrix} 1 & -1 \\ -1 & 1 \end{bmatrix} + \left(\frac{3h}{2}\right) \begin{bmatrix} 0 & 0 \\ 0 & 2a^{(i,j,n)} \end{bmatrix},
\end{aligned}$$

$i, k = 1, \dots, n,$
 $i, j = 1, \dots, n.$

The following statement plays very important role in all further arguments. It can be established by straightforward computations.

PROPOSITION 4.1. *The matrix \hat{C}_{11} of the system (3.23) can be defined by the relation*

$$\begin{aligned}
(\hat{C}_{11}\mathbf{u}, \mathbf{v}) &= \sum_{j,k=1}^n \sum_{i=1}^{n-1} \left(S_1^{(i,j,k)} \mathbf{u}_1^{(i,j,k)}, \mathbf{v}_1^{(i,j,k)} \right) + \sum_{i,k=1}^n \sum_{j=1}^{n-1} \left(S_2^{(i,j,k)} \mathbf{u}_2^{(i,j,k)}, \mathbf{v}_2^{(i,j,k)} \right) + \\
(4.2) \quad &+ \sum_{i,j=1}^n \sum_{k=1}^{n-1} \left(S_3^{(i,j,k)} \mathbf{u}_3^{(i,j,k)}, \mathbf{v}_3^{(i,j,k)} \right)
\end{aligned}$$

which is assumed to hold for any $\mathbf{u}, \mathbf{v} \in \mathbb{R}^M$, and $\mathbf{u}_l, \mathbf{v}_l$ are the restrictions of vectors \mathbf{u}, \mathbf{v} into \mathbb{R}^2 :

$$\mathbf{u}_1^{(i,j,k)} = \begin{bmatrix} u^{(i,j,k)} \\ u^{(i+1,j,k)} \end{bmatrix}, \quad \mathbf{u}_2^{(i,j,k)} = \begin{bmatrix} u^{(i,j,k)} \\ u^{(i,j+1,k)} \end{bmatrix}, \quad \mathbf{u}_3^{(i,j,k)} = \begin{bmatrix} u^{(i,j,k)} \\ u^{(i,j,k+1)} \end{bmatrix}.$$

Now define on Ω auxiliary cubic mesh $\tilde{\mathcal{T}}_C$ with vertices in the middle points of cubes $C^{(i,j,k)} \in \mathcal{T}_C$. Enumerate the nodes of this mesh accordingly enumeration of the cubes of \mathcal{T}_C and introduce for each node (i, j, k) of $\tilde{\mathcal{T}}_C$ the matrices

$$(4.3) \quad \tilde{S}_l^{(i,j,k)} = \tilde{K}_l^{(i,j,k)} \begin{bmatrix} 1 & -1 \\ -1 & 1 \end{bmatrix}, \quad l = 1, 2, 3.$$

Here coefficients $\tilde{K}_l^{(i,j,k)}$, $l = 1, 2, 3$ are given by

$$\begin{aligned}
\tilde{K}_1^{(i,j,k)} &= \left(\frac{3h}{2}\right) \frac{1}{2} \left[a_{\min}^{(i,j,k)} + a_{\min}^{(i,j-1,k)} + a_{\min}^{(i,j,k-1)} + a_{\min}^{(i,j-1,k-1)} \right], \\
(4.4) \quad \tilde{K}_2^{(i,j,k)} &= \left(\frac{3h}{2}\right) \frac{1}{2} \left[a_{\min}^{(i,j,k)} + a_{\min}^{(i-1,j,k)} + a_{\min}^{(i,j,k-1)} + a_{\min}^{(i-1,j,k-1)} \right], \\
\tilde{K}_3^{(i,j,k)} &= \left(\frac{3h}{2}\right) \frac{1}{2} \left[a_{\min}^{(i,j,k)} + a_{\min}^{(i-1,j,k)} + a_{\min}^{(i,j-1,k)} + a_{\min}^{(i-1,j-1,k)} \right],
\end{aligned}$$

where $a_{\min}^{(i,j,k)} = \min_{\alpha, \beta, \gamma=0,1} \{a^{(i+\alpha, j+\beta, k+\gamma)}\}$.

Define the matrix \tilde{C} by the relation

$$(4.5) \quad \begin{aligned} (\tilde{C}\mathbf{u}, \mathbf{v}) &= \sum_{j,k=1}^n \sum_{i=1}^{n-1} \left(\tilde{S}_1^{(i,j,k)} \mathbf{u}_1^{(i,j,k)}, \mathbf{v}_1^{(i,j,k)} \right) + \sum_{i,k=1}^n \sum_{j=1}^{n-1} \left(\tilde{S}_2^{(i,j,k)} \mathbf{u}_2^{(i,j,k)}, \mathbf{v}_2^{(i,j,k)} \right) \\ &+ \sum_{i,j=1}^n \sum_{k=1}^{n-1} \left(\tilde{S}_3^{(i,j,k)} \mathbf{u}_3^{(i,j,k)}, \mathbf{v}_3^{(i,j,k)} \right) \end{aligned}$$

and consider the eigenvalue problem

$$(4.6) \quad \hat{C}_{11}\mathbf{u} = \mu\tilde{C}\mathbf{u}, \quad \mathbf{u} \in \mathbb{R}^M.$$

PROPOSITION 4.2. *The eigenvalues of the problem (4.6) belong to the interval $[1/2, 1]$.*

Proof. Consider first eigenvalue problems

$$(4.7) \quad \begin{aligned} S_l^{(i,j,k)} \mathbf{u} &= \xi \tilde{S}_l^{(i,j,k)} \mathbf{u}, \quad (\tilde{S}_l^{(i,j,k)} \mathbf{u}, \mathbf{u}) \neq 0, \quad \mathbf{u} \in \mathbb{R}^2, \\ &l = 1, 2, 3, \quad i, j, k = 1, \dots, n-1. \end{aligned}$$

Direct calculations show that eigenvalues of the problems (4.7) are $\xi = K_l^{(i,j,k)} / \tilde{K}_l^{(i,j,k)}$.

For $l = 1$ using (3.22) and (4.4) we can write

$$\begin{aligned} K_1^{(i,j,k)} &= \left(\frac{3h}{2} \right) 2 \frac{a^{(i,j,k)} \cdot a^{(i+1,j,k)}}{a^{(i,j,k)} + a^{(i+1,j,k)}}, \\ \tilde{K}_1^{(i,j,k)} &= \left(\frac{3h}{2} \right) \frac{1}{2} \left[a_{\min}^{(i,j,k)} + a_{\min}^{(i,j-1,k)} + a_{\min}^{(i,j,k-1)} + a_{\min}^{(i,j-1,k-1)} \right]. \end{aligned}$$

Suppose that $a^{(i,j,k)} = a^{(i+1,j,k)} = a$. Then $K_1^{(i,j,k)} = \left(\frac{3h}{2} \right) a$ and taking into account the Assumption A1 in the expression (4.4) of $\tilde{K}_1^{(i,j,k)}$ at least two terms $a_{\min}^{(*)}$ are equal to a . Thus, possible cases are

$$\begin{aligned} \text{either } \tilde{K}_1^{(i,j,k)} &= \left(\frac{3h}{2} \right) \frac{1}{2} 4a, \\ \text{or } \tilde{K}_1^{(i,j,k)} &= \left(\frac{3h}{2} \right) \frac{1}{2} (3a + b), \quad \text{where } b \leq a, \\ \text{or } \tilde{K}_1^{(i,j,k)} &= \left(\frac{3h}{2} \right) \frac{1}{2} (2a + 2b), \end{aligned}$$

then we get, respectively,

$$\text{either } \xi = \frac{a}{2a}, \quad \text{or } \xi = \frac{2a}{3a+b}, \quad \text{or } \xi = \frac{a}{a+b},$$

with $b \leq a$. So, we obtain $\xi \in [1/2, 1]$.

If $a^{(i,j,k)} = a$ and $a^{(i+1,j,k)} = b \neq a$ (suppose $a \geq b$) then $K_1^{(i,j,k)} = \left(\frac{3h}{2} \right) 2 \frac{ab}{a+b}$, $\tilde{K}_1^{(i,j,k)} = \left(\frac{3h}{2} \right) 2b$ (by Assumption A1) and we obtain

$$\xi = \frac{K_1^{(i,j,k)}}{\tilde{K}_1^{(i,j,k)}} = \frac{a}{a+b} = \frac{1}{1+b/a} \in [1/2, 1].$$

For $l = 2, 3$ we have the same arguments.

Since all matrices $S_l^{(i,j,k)}$ and $\tilde{S}_l^{(i,j,k)}$, in the relations (4.2) and (4.5) are nonnegative then repeating the proof of Lemma 3.2 we obtain the conclusion of proposition. \square

Now instead of the matrix (3.21) we define new matrix \bar{B} by

$$(4.8) \quad \bar{B} = \left[\begin{array}{cc} \left[\begin{array}{cc} \tilde{C} + C_{12}C_{22}^{-1}C_{21} & C_{12} \\ C_{21} & C_{22} \end{array} \right] + B_{12}B_{22}^{-1}B_{21} & B_{12} \\ & B_{22} \end{array} \right].$$

Then we can formulate the following theorem

THEOREM 4.3. *The matrix \bar{B} defined in (4.8) with the block \tilde{C} defined in (4.5) is spectrally equivalent to the matrix A and*

$$\text{cond}(\bar{B}^{-1}A) \leq 20.$$

Proof. Proof is based on Proposition 4.2 and Theorem 3.6. \square

We remind here that matrices B_{22} and C_{22} are diagonal and taking \bar{B} as a preconditioner for the matrix A we have to develop procedure of solution the linear system of equations

$$(4.9) \quad \tilde{C}\mathbf{u} = \mathbf{G}, \quad \mathbf{u} \in \mathbb{R}^M.$$

Define on cubic mesh $\tilde{\mathcal{T}}_C$ standard partitioning into tetrahedra $\tilde{\mathcal{T}}_h$. Direct calculations show that the matrix \tilde{C} defined by (4.5) is finite element approximation of the boundary value problem

$$(4.10) \quad \begin{aligned} -\nabla \cdot (\tilde{a} \nabla u) &= g && \text{in } \Omega, \\ u &= 0 && \text{on } \partial\Omega, \end{aligned}$$

on the partitioning $\tilde{\mathcal{T}}_h$ where function \tilde{a} is defined to be constant on each cube $\tilde{C}^{(i,j,k)} \in \tilde{\mathcal{T}}_C$:

$$(4.11) \quad \tilde{a}(x) = \min_{\alpha, \beta, \gamma=0,1} \left\{ a^{(i+\alpha, j+\beta, k+\gamma)} \right\}, \quad x \in \tilde{C}^{(i,j,k)}.$$

We have to stress that the function $\tilde{a}(x)$ is piecewise constant. Thus, any multilevel procedure which works well for such kind of problems (4.10) can be used. Below we outline the multilevel domain decomposition method (MGDD) [16, 17, 18, 19] which we used to solve the problem (4.9).

4.1. Multilevel domain decomposition method. Here we assume that provided the Assumption A1 we can choose a positive $t \geq 1$ and for values $l = 0, 1, \dots, t$ find grid domains $\tilde{\Omega}_h^{(l)}$ as unions of pairwise disjoint cubes $\tilde{G}_i^{(l)}$, $i = 1, \dots, m_l$, with the edge length $h_l = 2^{-l}H$, where $m_l = 8^l m$ and $h_l = h = 1/n$. Then we partition each cube $G_i^{(l)}$, $i = 1, \dots, m$ into tetrahedra in such a way that the resultant tetrahedral partitioning of the domain Ω permits the application of the finite element method with piecewise-linear basis functions. Denote such tetrahedral partitions of the domain Ω by $\Omega_h^{(l)}$, $l = 0, 1, \dots, t$.

Let us consider variational problem: for given $g \in L_2(\Omega)$ find $u \in U = \{v \in H^1(\Omega) : v = 0 \text{ on } \partial\Omega\}$ such that

$$(4.12) \quad \int_{\Omega} \tilde{a} \nabla u \cdot \nabla v \, d\Omega = \int_{\Omega} gv \, d\Omega, \quad \forall v \in U,$$

where \tilde{a} is defined by (4.11).

Determine a sequence of spaces $U_h^{(l)}$ as a set of functions continuous in Ω linear in each tetrahedron from $\Omega_h^{(l)}$, $l = 0, 1, \dots, t$, and vanishing on $\partial\Omega$ and denote the dimensions of such spaces by $M_l = \dim U_h^{(l)}$. To approximate the problem (4.12) we consider the finite element problem: find $u_h \in U_h \equiv U_h^{(t)}$ such that

$$(4.13) \quad \int_{\Omega} \tilde{a} \nabla u_h \cdot \nabla v \, d\Omega = \int_{\Omega} gv \, d\Omega, \quad \forall v \in U_h,$$

which leads to the system (4.9) with the symmetric positive definite $M \times M$ matrix \tilde{C} and the vector $\mathbf{G} \in \mathbb{R}^M$. Here M is equal to the dimension of the space U_h : $M = M_t \equiv n^3$. Then we assume that the utilized tetrahedral partitioning of the domain Ω is such that the system (4.9) is a classical 7-point difference scheme.

Following [16], define now the sequence of grids $\hat{\Sigma}_h^{(l)}$ as unions of faces $\partial G_i^{(l-1)}$, $i = 1, \dots, m_{l-1}$ with the edge length h_{l-1}

$$\hat{\Sigma}_h^{(l)} = \bigcup_{i=1}^{m_{l-1}} \partial G_i^{(l-1)},$$

and the sequence of grids $\Sigma_h^{(l)}$ as restrictions of grids $\Omega_h^{(l)}$ into $\hat{\Sigma}_h^{(l)}$, for $l = 1, \dots, t$.

Also define the sequence of grids $\Gamma_h^{(l)}$ as unions of edges of cubes $G_i^{(l)}$, $i = 1, \dots, m_l$, and the sequence of grids $\Gamma_h^{(l-1/2)}$, which differ from the grids $\Gamma_h^{(l-1)}$ by additional nodes in the middle of the edges of $G_i^{(l-1)}$, $i = 1, \dots, m_{l-1}$, for $l = 1, \dots, t$, as it is shown on Figure 3.

Let us denote the set of the faces of the cubes $G_i^{(l)}$, $i = 1, \dots, m_l$ by $P_i^{(l)}$, $i = 1, \dots, s_l$, where s_l is the number of these faces $\partial G_i^{(l)}$, $l = 0, 1, \dots, t$. Then

$$\begin{aligned} \hat{\Sigma}_h^{(l)} &= \bigcup_{i=1}^{s_{l-1}} P_i^{(l-1)}, \\ \Gamma_h^{(l)} &= \bigcup_{i=1}^{s_{l-1}} \partial P_i^{(l-1)}. \end{aligned}$$

Thus, grid domains $\hat{\Omega}_h^{(l)}$ consist of cubes, grid domains $\Omega_h^{(l)}$ consist of tetrahedra, grids $\Sigma_h^{(l)}$ consist of squares, and grids $\Gamma_h^{(l)}$ and $\Gamma_h^{(l-1/2)}$ consist of edges of length h_l , $l = 0, 1, \dots, t$.

Let us partition the nodes of the grid domain $\Omega_h^{(l)}$ into four groups (see Figure 3):

1. to the first group we refer the vertices of the cubes $G_i^{(l-1)}$ (the nodes of $\Gamma_h^{(l-1)}$),
2. to the second group we refer the centers of the edges of these cubes (the nodes of $\Gamma_h^{(l-1/2)}$ which are not in $\Gamma_h^{(l-1)}$),
3. to the third group we refer the centers of the sides of the cubes (the nodes of $\Sigma_h^{(l)}$ which are not in $\Gamma_h^{(l-1/2)}$),
4. and to the fourth group we refer all the remaining nodes which are at the same time the centers of the cubes $G_i^{(l)}$, $i = 1, \dots, m_{l-1}$.

According to such partitioning of the nodes any vector $\mathbf{v} \in \mathbb{R}^{M_l}$ (M_l is the number of nodes of $\Omega_h^{(l)}$) can be represented in the form $\mathbf{v} = (\mathbf{v}_1^T, \mathbf{v}_2^T, \mathbf{v}_3^T, \mathbf{v}_4^T)^T$,

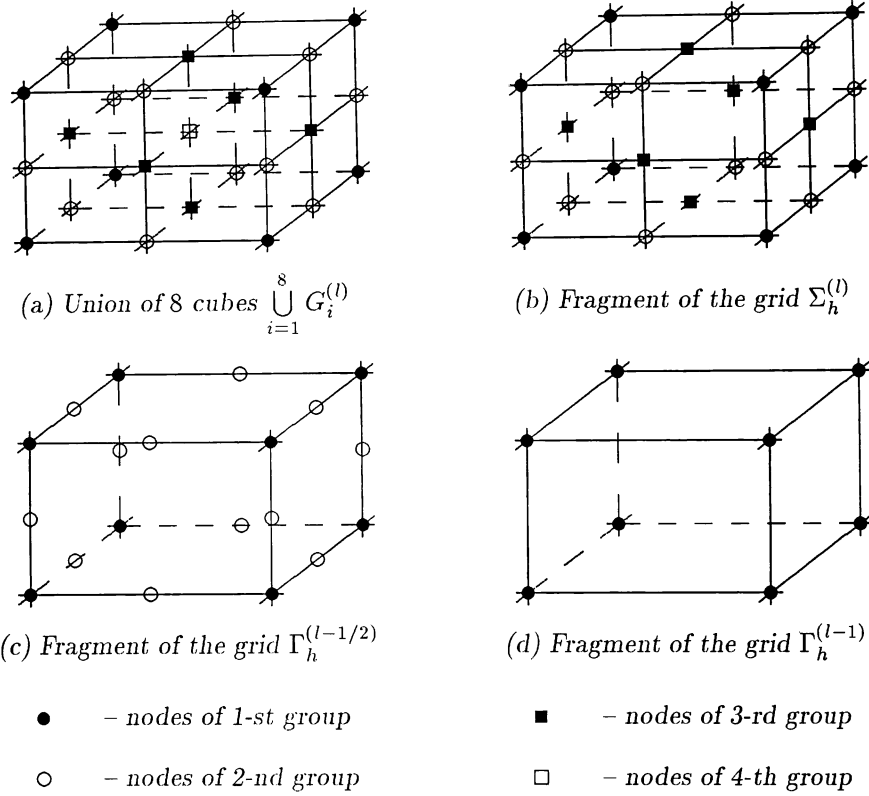

FIGURE 3. Fragments of the grids $\Omega_h^{(l)}$, $\Sigma_h^{(l)}$, $\Gamma_h^{(l-1/2)}$, $\Gamma_h^{(l-1)}$ and partitioning of the nodes into groups

where $\mathbf{v}_1 \in \mathbb{R}^{M_{l-1}}$, $\mathbf{v}_4 \in \mathbb{R}^{m_{l-1}}$, and $\mathbf{v}_3 \in \mathbb{R}^{s_{l-1}}$. Considering the equation (4.13) in the spaces $U_h^{(l)}$ we define the sequence of matrices $\tilde{C}^{(l)}$ which according to the partitioning of nodes introduced above can be presented in the following block form

$$(4.14) \quad \tilde{C}^{(l)} = \begin{bmatrix} \tilde{C}_{11}^{(l)} & \tilde{C}_{12}^{(l)} & 0 & 0 \\ \tilde{C}_{21}^{(l)} & \tilde{C}_{22}^{(l)} & \tilde{C}_{23}^{(l)} & 0 \\ 0 & \tilde{C}_{32}^{(l)} & \tilde{C}_{33}^{(l)} & \tilde{C}_{34}^{(l)} \\ 0 & 0 & \tilde{C}_{43}^{(l)} & \tilde{C}_{44}^{(l)} \end{bmatrix}.$$

Note that $\tilde{C}_{ii}^{(l)}$, $i = 1, 2, 3, 4$ are diagonal matrices and the matrix $\tilde{C}^{(l)}$ coincides with the matrix \tilde{C} from (4.9).

Define $V_h^{(l)}$ and $W_h^{(l-1/2)}$ as the spaces of restrictions of functions from $U_h^{(l)}$ into $\Sigma_h^{(l)}$ and $\Gamma_h^{(l-1/2)}$, respectively, $l = 1, \dots, t$.

Then, following [17, 19] using relations

$$(4.15) \quad (\tilde{D}^{(l)} \tilde{\mathbf{u}}, \tilde{\mathbf{v}}) = \sum_{i=1}^{m_{l-1}} \frac{h_l}{2} \int_{\Sigma_h^{(l)}} \tilde{a} \nabla \tilde{u}_h \nabla \tilde{v}_h \, ds, \quad \forall \tilde{u}_h, \tilde{v}_h \in V_h^{(l)},$$

define symmetric positive definite $(N_l - m_{l-1}) \times (N_l - m_{l-1})$ -matrices

$$(4.16) \quad \tilde{D}^{(l)} = \begin{bmatrix} \tilde{D}_{11}^{(l)} & \tilde{D}_{12}^{(l)} & 0 \\ \tilde{D}_{21}^{(l)} & \tilde{D}_{22}^{(l)} & D^{(l)}_{23} \\ 0 & D^{(l)}_{32} & D^{(l)}_{33} \end{bmatrix},$$

and using the relations

$$(4.17) \quad \left(\hat{D}^{(l)} \mathbf{u}, \mathbf{v} \right) = \sum_{i=1}^{s_{l-1}} \frac{h_i^2}{4} \int_{\Gamma_h^{(l-1/2)}} \tilde{a} \frac{du_h}{ds} \frac{dv_h}{ds} ds, \quad \forall u_h, v_h \in W_h^{(l-1/2)},$$

define symmetric positive definite $n_l \times n_l$ -matrices

$$(4.18) \quad \hat{D}^{(l)} = \begin{bmatrix} \hat{D}_{11}^{(l)} & D^{(l)}_{12} \\ D^{(l)}_{21} & D^{(l)}_{22} \end{bmatrix},$$

where $n_l = M_l - m_{l-1} - s_{l-1}$, for $l = 1, \dots, t$.

Now define symmetric positive definite $M_l \times M_l$ matrices

$$(4.19) \quad D^{(l)} = \begin{bmatrix} D_{11} + D_{12}D_{22}^{-1}D_{21} & D_{12} & 0 & 0 \\ D_{21} & D_{22} + D_{23}D_{33}^{-1}D_{32} & D_{23} & 0 \\ 0 & D_{32} & D_{33} + D_{34}D_{44}^{-1}D_{43} & D_{34} \\ 0 & 0 & D_{43} & D_{44} \end{bmatrix} = F_l^T [D_{11} \otimes D_{22} \otimes D_{33} \otimes D_{44}] F_l,$$

where

$$D_{11} = \hat{D}_{11} - D_{12}D_{22}^{-1}D_{21}, \quad D_{34} = \tilde{C}_{34}, \quad D_{44} = \tilde{C}_{44},$$

$$F_l = \begin{bmatrix} I_{11} & 0 & 0 & 0 \\ D_{22}^{-1}D_{21} & I_{22} & 0 & 0 \\ 0 & D_{33}^{-1}D_{32} & I_{33} & 0 \\ 0 & 0 & D_{44}^{-1}D_{43} & I_{44} \end{bmatrix},$$

and index l of matrices D_{ij} , \tilde{C}_{ij} , and I_{ij} , $i, j = 1, 2, 3, 4$ was skipped for simplicity.

By making straightforward calculations [16] it can be shown that the following statement is true.

$$\text{LEMMA 4.4.} \quad D_{11}^{(l)} = \frac{1}{4} \tilde{C}^{(l-1)}, \quad l = 1, \dots, t.$$

Define now multilevel preconditioner for the matrix \tilde{C} from (4.9). Using (4.14)–(4.19) define the sequence of the preconditioners $D^{(l)}$ for matrices $\tilde{C}^{(l)}$. Fix some integer $r \geq 1$ and define $H_{11}^{(2)} = [\hat{D}^{(1)}]^{-1} \equiv [D^{(1)}]^{-1}$. Then following [16] for $l = 2, \dots, t$ define the sequence of $M_{l-1} \times M_{l-1}$ -matrices

$$(4.20) \quad R_{11}^{(l)} = \left[I_{11}^{(l)} - \prod_{j=1}^r \left(I_{11}^{(l)} - \tau_j H_{11}^{(l)} \tilde{C}^{(l-1)} \right) \right] \left[\tilde{C}^{(l-1)} \right]^{-1},$$

$$\hat{D}_{11}^{(l)} = \frac{1}{4} \left[R_{11}^{(l)} \right]^{-1},$$

where the parameters τ_j , $j = 1, \dots, r$, are chosen such that the polynomial

$$T_r(x) = \prod_{j=1}^r (1 - \tau_j x)$$

is least deviating from zero on the interval $[d_1, d_2]$, where the constants d_1, d_2 are the boundaries of the spectrum of the matrix $H_{11}^{(l)} D^{(l)}_{11}$.

Then, define $M_l \times M_l$ -matrices

$$(4.21) \quad \begin{aligned} \widehat{D}^{(l)} &= F_l^T \left[\widehat{D}_{11}^{(l)} \otimes D^{(l)}_{22} \otimes D^{(l)}_{33} \otimes D^{(l)}_{44} \right] F_l, \\ H_{11}^{(l+1)} &= \left[\widehat{D}^{(l)} \right]^{-1}, \quad l = 2, \dots, t. \end{aligned}$$

Finally, set the matrix

$$(4.22) \quad D = \widehat{D}^{(t)}$$

as a multilevel preconditioner for the matrix \tilde{C} of the problem (4.9).

The following statements can be proved [16, 17].

LEMMA 4.5. *The eigenvalues of the matrices $[D^{(l)}]^{-1} \tilde{C}^{(l)}$ belong to the interval $[1, b]$, where $b = (7 + \sqrt{19})/2$, and*

$$\text{cond} \left[D^{(l)} \right]^{-1} \tilde{C}^{(l)} \leq b < 5.68, \quad l = 1, \dots, t.$$

LEMMA 4.6. *The following estimates are valid:*

$$\text{if } r = 3 \text{ then} \quad \text{cond } D^{-1} \tilde{C} \leq \frac{3\sqrt{b}-1}{3-\sqrt{b}} < 9.97,$$

$$\text{if } r = 4 \text{ then} \quad \text{cond } D^{-1} \tilde{C} \leq \nu_{max} < 6.6,$$

where

$$\nu_{max} = \frac{2\sqrt{2b-2\sqrt{b}+1} - 3\sqrt{b} - 2}{4 - \sqrt{b}}.$$

Let us apply the generalized conjugate gradient method to solve the system (4.9) with the matrix \tilde{C} :

$$(4.23) \quad \begin{aligned} \mathbf{u}^{k+1} &= \mathbf{u}^k - \frac{1}{q_k} \left[D^{-1} \xi^k - e_{k-1} (\mathbf{u}^k - \mathbf{u}^{k-1}) \right] \\ q_k &= \frac{\|D^{-1} \xi^k\|_{\tilde{C}}^2}{\|\xi^k\|_{D^{-1}}^2} - e_{k-1}, \quad e_k = q_k \frac{\|\xi^{k+1}\|_{D^{-1}}^2}{\|\xi^k\|_{D^{-1}}^2} \\ e_0 &= 0, \quad k = 1, \dots, k_\varepsilon \end{aligned}$$

with matrix D from (4.22) for the value $r = 3$ or $r = 4$, where $\xi^k = \tilde{C} \mathbf{u}^k - \mathbf{G}$ and $\|\xi\|_{\tilde{C}} = (\tilde{C} \xi, \xi)^{1/2}$, $\xi \in \mathbb{R}^M$.

Choose the quantity k_ε in such a way that a given positive ε ($\varepsilon \ll 1$) will surely satisfy the inequality

$$(4.24) \quad \|\mathbf{u}^{k_\varepsilon+1} - \mathbf{u}^*\|_{\tilde{C}} \leq \varepsilon \|\mathbf{u}^0 - \mathbf{u}^*\|_{\tilde{C}}.$$

where $\mathbf{u}^* = \tilde{C}^{-1}\mathbf{G}$, for any initial guess $\mathbf{u}^0 \in \mathbb{R}^M$.

Taking into account that the method (4.23) obeys the estimate

$$(4.25) \quad \|\mathbf{u}^k - \mathbf{u}^*\|_{\tilde{C}} \leq \frac{2q^k}{1+q^{2k}} \|\mathbf{u}^0 - \mathbf{u}^*\|_{\tilde{C}},$$

where $q = (\sqrt{\nu} - 1)/(\sqrt{\nu} + 1)$ and ν is an arbitrary but fixed positive number such that $\text{cond } D^{-1}\tilde{C} \leq \nu$, we can choose for the required value of k_ε the maximal integer satisfying the inequality

$$(4.26) \quad k_\varepsilon \leq \frac{\ln \varepsilon/2}{\ln q}.$$

The following statements can be established ([17]).

THEOREM 4.7. *To solve the system (4.9) with the accuracy ε in the sense of inequality (4.24) by the generalized conjugate gradient method (4.23) with the matrix D from (4.22) it is sufficient to choose $k_\varepsilon = \lceil 1.53 \ln \frac{2}{\varepsilon} \rceil$ in the case of $r = 3$ and $k_\varepsilon = \lceil 1.22 \ln \frac{2}{\varepsilon} \rceil$ in the case of $r = 4$, where $\lceil z \rceil$ denotes the integer part of number z .*

The number of arithmetic operations required in this case for the values $r = 3$ and $r = 4$ can be estimated from above by the quantities $75M \ln \frac{2}{\varepsilon}$ and $70M \ln \frac{2}{\varepsilon}$, respectively.

Note that the condition numbers of the matrices $D^{-1}\tilde{C}$ determined in the Lemma 4.6 do not depend on mesh size h and the jump of the coefficients $\tilde{a}(x)$. So, applying preconditioned conjugate gradient method to solve the problem (2.4) with the matrix \tilde{B} from (4.8) as a preconditioner for the matrix A and using multilevel domain decomposition method (MGDD) to solve the problem (4.9) with matrix \tilde{C} we establish the following results.

THEOREM 4.8. *If we use MGDD method to solve problem (4.9) with matrix \tilde{C} then condition number $\text{cond}(\tilde{B}^{-1}A)$ does not depend on mesh size h and jump of the coefficients $a(x)$.*

THEOREM 4.9. *The number of operations for solving system*

$$A\lambda = \mathbf{F}$$

by preconditioned conjugate gradient method with preconditioner \tilde{B} and with accuracy ε in the sense

$$\|\lambda^{k_\varepsilon+1} - \lambda^*\|_A \leq \varepsilon \|\lambda^0 - \lambda^*\|_A,$$

is estimated by $C \cdot N \cdot \ln \frac{2}{\varepsilon}$, where $\lambda^ = A^{-1}\mathbf{F}$, $\lambda^0 \in \mathbb{R}^N$ and C does not depend on N and jump of the coefficients $a(x)$.*

5. Results of the numerical experiments. In this section the preconditioners (3.21) and (4.8) are tested on the model problem

$$\begin{aligned} -\nabla \cdot (a(x)\nabla u) &= f, & \text{in } \Omega = [0, 1]^3 \\ u &= 0, & \text{on } \partial\Omega \end{aligned}$$

We present three numerical examples. In the first example we use the preconditioner \tilde{B} in the form (3.21). The problem with $M \times M$ -matrix \tilde{C}_{11} is solved by preconditioned conjugate gradient with diagonal Jacobi preconditioner. In the second example we use the preconditioner \tilde{B} in the form (4.8). The problem with matrix \tilde{C} is solved by multilevel domain decomposition method as it is described in the section 4.1.

The domain is divided into $M = n^3$ cubes (n in each direction) and each cube is partitioned into 5 tetrahedra. The dimension of the original algebraic system is $N = 10n^3 - 6n^2$. The right hand side is generated randomly, and the accuracy parameter is taken as $\varepsilon = 10^{-6}$. The condition numbers of the preconditioned matrices $B^{-1}A$ are calculated by the relation between the conjugate gradient and Lanczos algorithms [15]. The coefficient $a(x)$ is piecewise constant and is defined to be

$$(5.1) \quad a(x, y, z) = \begin{cases} a, & (x, y, z) \in [0.5, 1] \times [0.5, 1] \times [0.5, 1] \\ 1, & \text{elsewhere} \end{cases}$$

The results are summarized in Tables 1 and 2, where n_{iter} and cond denote the iteration number and condition number, respectively. All experiments are carried out on Sun Workstation.

Finally, the method of preconditioning described in this paper is used to solve the problem (1.2) with the constant right-hand-side function $f(x)$ by the mixed finite element method with the function $a(x)$ in the following form (see Figure 4):

$$(5.2) \quad a(x, y, z) = \begin{cases} a = 0.01, & (x, y, z) \in \left\{ \begin{array}{l} [0.2, 0.4] \times [0.2, 0.4] \times [0.2, 0.4] \cup \\ [0.6, 0.8] \times [0.2, 0.4] \times [0.2, 0.4] \cup \\ [0.2, 0.4] \times [0.6, 0.8] \times [0.2, 0.4] \cup \\ [0.6, 0.8] \times [0.6, 0.8] \times [0.2, 0.4] \cup \\ [0.2, 0.4] \times [0.2, 0.4] \times [0.6, 0.8] \cup \\ [0.6, 0.8] \times [0.2, 0.4] \times [0.6, 0.8] \cup \\ [0.2, 0.4] \times [0.6, 0.8] \times [0.6, 0.8] \cup \\ [0.6, 0.8] \times [0.6, 0.8] \times [0.6, 0.8] \end{array} \right\} \\ 1, & \text{elsewhere} \end{cases}$$

Again, the domain Ω is the unit cube, the domain is divided into $M = 40^3 = 64000$ cubes. The dimension of the original algebraic system for the Lagrange multipliers (2.4) is $N = 630400$. Both preconditioners (3.21) and (4.8) are tested on this problem.

With the preconditioner in the form (3.21), i.e. three-level preconditioner, it takes $n_{\text{iter}} = 18$ outer iterations to solve (2.4) with the accuracy $\varepsilon = 10^{-6}$. On each iteration the problem (3.20) is solved by preconditioned conjugate gradient method. It takes less than 40 iterations to solve (3.20) with the accuracy $\varepsilon = 10^{-8}$.

With the preconditioner in the form (4.8), i.e. multilevel preconditioner when MGDD method is used to solve the problem (4.9), it takes $n_{\text{iter}} = 22$ outer iterations to solve (2.4). On each outer iteration it takes 18 iterations to solve (4.9) with the accuracy $\varepsilon = 10^{-8}$.

In both cases it takes less than 12 minutes to obtain the resulting vectors \mathbf{q} and \mathbf{u} . The slices of the solution \mathbf{u} by planes parallel to xy -plane are shown in Figure 5.

REFERENCES

- [1] T. Arbogast and Z. Chen, On the implementation of mixed methods as nonconforming methods for second order elliptic problems, IMA Preprint #1172, 1993. (*Submitted to Math. Comp.*)
- [2] D.N. Arnold and F. Brezzi, Mixed and nonconforming finite element methods: implementation, postprocessing and error estimates, *RAIRO Model. Math. Anal. Numer.*, **19** (1985), 7–32.
- [3] O. Axelsson, On multigrid methods of the two-level type, *Multigrid methods, Proceedings, Köln-Porz, 1981*, (Eds. W. Hackbush and U. Trottenberg), LNM **960**, Springer, 1982, 352–367.
- [4] J.H. Bramble, J.F. Pasciak, and A.H. Schatz, An iterative method for elliptic problems on regions partitioned into substructures, *Math. Comp.*, **46** (1986), 361–369.

TABLE 1. Solving \hat{C}_{11} with Jacoby preconditioning

a	$20 \times 20 \times 20$ $N = 77600$		$30 \times 30 \times 30$ $N = 264600$		$40 \times 40 \times 40$ $N = 630400$		$50 \times 50 \times 50$ $N = 1235000$	
	n_{iter}	cond	n_{iter}	cond	n_{iter}	cond	n_{iter}	cond
1	15	6.20	15	6.15	14	6.03	14	6.02
10	17	7.59	17	7.59	17	7.59	17	7.58
100	18	7.86	18	7.85	17	7.84	17	7.83
1000	18	7.90	18	7.90	17	7.88	17	7.88
10^4	18	7.90	18	7.90	17	7.88	17	7.88
0.1	16	7.11	16	7.10	16	7.10	16	7.10
0.01	16	7.11	16	7.10	16	7.10	16	7.10
0.001	16	7.11	16	7.10	16	7.10	16	7.10
10^{-4}	16	7.11	16	7.10	16	7.10	16	7.10

TABLE 2. Solving \hat{C} by MGDD method

a	$20 \times 20 \times 20$ $N = 77600$		$30 \times 30 \times 30$ $N = 264600$		$40 \times 40 \times 40$ $N = 630400$		$50 \times 50 \times 50$ $N = 1235000$	
	n_{iter}	cond	n_{iter}	cond	n_{iter}	cond	n_{iter}	cond
1	20	10.6	19	10.4	19	10.3	19	10.3
10	21	12.6	21	12.8	22	12.9	22	12.9
100	22	12.8	22	12.9	22	12.9	22	13.0
1000	22	12.9	22	12.9	22	12.9	22	13.0
10^4	22	12.9	22	12.9	22	12.9	22	13.0
0.1	21	11.7	22	11.8	21	11.9	21	11.9
0.01	22	11.8	22	11.8	21	11.9	21	11.9
0.001	22	11.9	22	11.8	21	11.9	21	12.0
10^{-4}	22	11.9	22	11.8	21	11.9	21	12.0

- [5] F. Brezzi, J. Douglas, Jr., R. Durán, and M. Fortin, Mixed finite elements for second order elliptic problems in three variables, *Numer. Math.*, **51** (1987), 237–250.
- [6] F. Brezzi, J. Douglas, Jr., and L. D. Marini, Two families of mixed finite elements for second order elliptic problems, *Numer. Math.*, **47** (1985), 217–235.
- [7] F. Brezzi and M. Fortin, *Mixed and Hybrid Finite Element Methods*, Springer-Verlag, New York, Berlin, Heidelberg, 1991.
- [8] S.C. Brenner, A multigrid algorithm for the lowest-order Raviart-Thomas mixed triangular finite element method, *SIAM J. Numer. Anal.*, **29** (1992), 647–678.
- [9] Z. Chen, Analysis of mixed methods using conforming and nonconforming finite element methods, *RAIRO Math. Model. Numer. Anal.*, **27** (1993), 9–34.
- [10] Z. Chen, R.E. Ewing, Yu. Kuznetsov, R. Lazarov, and S. Maliassov, Multilevel preconditioners for mixed methods for second order elliptic problems, IMA Preprint #1269, 1994. (*Submitted to SIAM Numer. Anal.*)
- [11] J. Douglas and J. Wang, A new family of mixed finite element spaces over rectangles, *Comp. Appl. Math.*, **12** (1993), 183–197.
- [12] R.E. Ewing, Yu. Kuznetsov, R. Lazarov, and S. Maliassov, Substructuring preconditioning for finite element approximations of second order elliptic problems. I. Nonconforming linear elements for the Poisson equation in parallelepiped, ISC-94-2-MATH Technical Report, TAMU, 1994.
- [13] R.E. Ewing, Yu. Kuznetsov, R. Lazarov, and S. Maliassov, Preconditioning of nonconforming finite element approximations of second order elliptic problems, *Proceedings of the Third Int. Conf. on Advances in Numerical Methods and Applications*, Bulgaria, 1994 (I.T. Dimov, Bl. Sendov, P.S. Vassilevski, eds.), 101–110

- [14] P. Grisvard, *Elliptic Problems in Nonsmooth Domains*, Pitman, Boston, Massachusetts, 1985.
- [15] G.M. Golub and C.F. Van Loan, *Matrix Computations*, Johns Hopkins University Press, 1989.
- [16] Yu. Kuznetsov, Multigrid domain decomposition methods for elliptic problems, *Proceedings of VII-th Int. Conf. on Comput. Methods for Applied Science and Engineering*, **2** (1987), 605–616.
- [17] Yu. Kuznetsov, Multigrid domain decomposition methods, *Proceedings of 3rd International Symposium on Domain Decomposition Methods*, 1989 (T. Chan, R. Glowinski, J. Periaux, O. Widlund, eds.), SIAM, Philadelphia, 1990. 290–313.
- [18] Yu. Kuznetsov, Multilevel domain decomposition methods, *Appl. Numer. Math.*, **6** (1989/90), 186–193.
- [19] S. Maliassov, Numerical analysis of the three-body problem with Coulomb interaction, *Dissertation, Institute of Numerical Mathematics*, Moscow, Russia, 1993 (in Russian).
- [20] L. D. Marini, An inexpensive method for the evaluation of the solution of the lowest order Raviart–Thomas mixed method, *SIAM J. Numer. Anal.*, **22** (1985), 493–496.
- [21] J. C. Nedelec, Mixed finite elements in \mathbf{R}^3 , *Numer. Math.*, **35** (1980), 315–341.
- [22] P.A. Raviart and J.M. Thomas, A mixed finite element method for second order elliptic problems, In: *Mathematical aspects of the FEM, Lecture Notes in Mathematics*, **606**, Springer-Verlag, Berlin & New York (1977), 292–315.

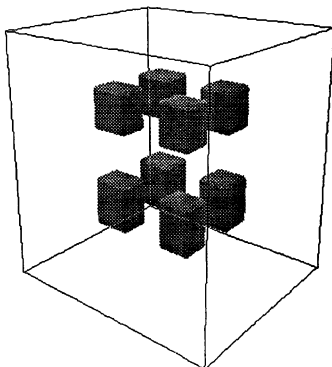
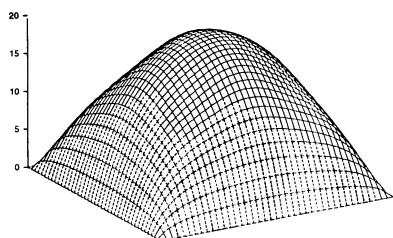
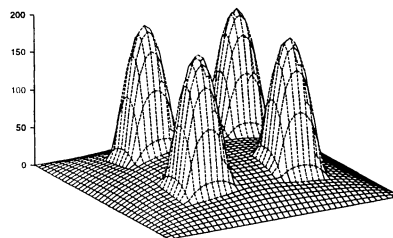
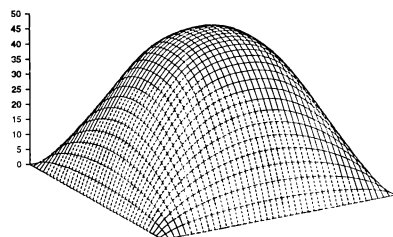
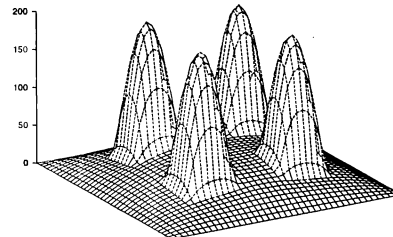
FIGURE 4. *Function $a(x)$ for the model problem (5.2)*(a) *Slice on $z = 0.1$* (b) *Slice on $z = 0.3$* (c) *Slice on $z = 0.5$* (d) *Slice on $z = 0.7$* FIGURE 5. *Slices of the solution parallel to xy -plane*

#	Author/s	Title
1189	Frank H. Shaw & Charles J. Geyer,	Constrained covariance component models
1190	Tomasz Luczaka,	A greedy algorithm estimating the height of random trees
1191	Timo Seppäläinen,	Maximum entropy principles for disordered spins
1192	Yuandan Lin, Eduardo D. Sontag & Yuan Wang,	Recent results on Lyapunov-theoretic techniques for nonlinear stability
1193	Svante Janson,	Random regular graphs: Asymptotic distributions and contiguity
1194	Rachid Ababou,	Random porous media flow on large 3-D grids: Numerics, performance, & application to homogenization
1195	Moshe Fridman,	Hidden Markov model regression
1196	Petr Klouček, Bo Li & Mitchell Luskin,	Analysis of a class of nonconforming finite elements for Crystalline microstructures
1197	Steven P. Lalley,	Random series in inverse Pisot powers
1198	Rudy Yaksick,	Expected optimal exercise time of a perpetual American option: A closed-form solution
1199	Rudy Yaksick,	Valuation of an American put catastrophe insurance futures option: A Martingale approach
1200	János Pach, Farhad Shahrokhi & Mario Szegedy,	Application of the crossing number
1201	Avner Friedman & Chaocheng Huang,	Averaged motion of charged particles under their self-induced electric field
1202	Joel Spencer,	The Erdős-Hanani conjecture via Talagrand's inequality
1203	Zhangxin Chen,	Superconvergence results for Galerkin methods for wave propagation in various porous media
1204	Russell Lyons, Robin Pemantle & Yuval Peres,	When does a branching process grow like its mean? Conceptual proofs of $L \log L$ criteria
1205	Robin Pemantle,	Maximum variation of total risk
1206	Robin Pemantle & Yuval Peres,	Galton-Watson trees with the same mean have the same polar sets
1207	Robin Pemantle,	A shuffle that mixes sets of any fixed size much faster than it mixes the whole deck
1208	Itai Benjamini, Robin Pemantle & Yuval Peres,	Martin capacity for Markov chains and random walks in varying dimensions
1209	Włodzimierz Bryc & Amir Dembo,	On large deviations of empirical measures for stationary Gaussian processes
1210	Martin Hildebrand,	Some random processes related to affine random walks
1211	Alexander E. Mazel & Yurii M. Suhov,	Ground states of a Boson quantum lattice model
1212	Roger L. Fosdick & Darren E. Mason,	Single phase energy minimizers for materials with nonlocal spatial dependence
1213	Bruce Hajek,	Load balancing in infinite networks
1214	Petr Klouček,	The transonic flow problems stability analysis and numerical results
1215	Petr Klouček,	On the existence of the entropic solutions for the transonic flow problem
1216	David A. Schmidt & Chjan C. Lim,	Full sign-invertibility and symplectic matrices
1217	Piermarco Cannarsa & Maria Elisabetta Tessitore,	Infinite dimensional Hamilton-Jacobi equations and Dirichlet boundary control problems of parabolic type
1218	Zhangxin Chen,	Multigrid algorithms for mixed methods for second order elliptic problems
1219	Zhangxin Chen,	Expanded mixed finite element methods for linear second order elliptic problems I
1220	Gang Bao,	A note on the uniqueness for an inverse diffraction problem
1221	Moshe Fridman,	A two state capital asset pricing model
1222	Paolo Baldi,	Exact asymptotics for the probability of exit from a domain and applications to simulation
1223	Carl Dou & Martin Hildebrand,	Enumeration and random random walks on finite groups
1224	Jaksa Cvitanic & Ioannis Karatzas,	On portfolio optimization under "drawdown" constraints
1225	Avner Friedman & Yong Liu,	A free boundary problem arising in magnetohydrodynamic system
1226	Dominic Welsh,	Randomised approximation schemes for Tutte-Gröthendieck invariants
1227	Zhangxin Chen, Bernardo Cockburn, Carl L. Gardner, & Joseph W. Jerome,	Quantum hydrodynamic simulation of hysteresis in the resonant tunneling diode
1228	E.G. Kalnins, G.C. Williams, & Willard Miller, Jr.,	Intrinsic characterisation of the separation constant for spin one and gravitational perturbations in Kerr geometry
1229	Zhangxin Chen,	Large-scale averaging analysis of multiphase flow in fractured reservoirs
1230	Bruce Hajek & Babu Narayanan,	Multigraphs with the most edge covers
1231	K.B. Athreya,	Entropy maximization
1232	F.I. Karpelevich & Yu.M. Suhov,	Functional equations in the problem of boundedness of stochastic branching dynamics
1233	E. Dibenedetto & V. Vespri,	On the singular equation $\beta(u)_t = \Delta u$
1234	M.Ya. Kelbert & Yu.M. Suhov,	The Markov branching random walk and systems of reaction-diffusion (Kolmogorov-Petrovskii-Piskunov) equations
1235	M. Hildebrand,	Random walks on random regular simple graphs

- 1236 **W.S. Don & A. Solomonoff**, Accuracy enhancement for higher derivatives using Chebyshev collocation and a mapping technique
- 1237 **D. Gurarie**, Symmetries and conservation laws of two-dimensional hydrodynamics
- 1238 **Z. Chen**, Finite element methods for the black oil model in petroleum reservoirs
- 1239 **G. Bao & A. Friedman**, Inverse problems for scattering by periodic structure
- 1240 **G. Bao**, Some inverse problems in partial differential equations
- 1241 **G. Bao**, Diffractive optics in periodic structures: The TM polarization
- 1242 **C.C. Lim & D.A. Schmidt**, On noneven digraphs and symplectic pairs
- 1243 **H.M. Soner, S.E. Shreve & J. Cvitanić**, There is no nontrivial hedging portfolio for option pricing with transaction costs
- 1244 **D.L. Russell & B-Yu Zhang**, Exact controllability and stabilizability of the Korteweg-de Vries equation
- 1245 **B. Morton, D. Enns & B-Yu Zhang**, Stability of dynamic inversion control laws applied to nonlinear aircraft pitch-axis models
- 1246 **S. Hansen & G. Weiss**, New results on the operator Carleson measure criterion
- 1247 **V.A. Malyshev & F.M. Spiessma**, Intrinsic convergence rate of countable Markov chains
- 1248 **G. Bao, D.C. Dobson & J.A. Cox**, Mathematical studies in rigorous grating theory
- 1249 **G. Bao & W.W. Symes**, On the sensitivity of solutions of hyperbolic equations to the coefficients
- 1250 **D.A. Huntley & S.H. Davis**, Oscillatory and cellular mode coupling in rapid directional solidification
- 1251 **M.J. Donahue, L. Gurvits, C. Darken & E. Sontag**, Rates of convex approximation in non-Hilbert spaces
- 1252 **A. Friedman & B. Hu**, A Stefan problem for multi-dimensional reaction diffusion systems
- 1253 **J.L. Bona & B-Y. Zhang**, The initial-value problem for the forced Korteweg-de Vries equation
- 1254 **A. Friedman & R. Gulliver**, **Organizers**. Mathematical modeling for instructors
- 1255 **S. Kichenassamy**, The prolongation formula for tensor fields
- 1256 **S. Kichenassamy**, Fuchsian equations in Sobolev spaces and blow-up
- 1257 **H.S. Dumas, L. Dumas, & F. Golse**, On the mean free path for a periodic array of spherical obstacles
- 1258 **C. Liu**, Global estimates for solutions of partial differential equations
- 1259 **C. Liu**, Exponentially growing solutions for inverse problems in PDE
- 1260 **Mary Ann Horn & I. Lasiecka**, Nonlinear boundary stabilization of parallelly connected Kirchhoff plates
- 1261 **B. Cockburn & H. Gau**, A posteriori error estimates for general numerical methods for scalar conservation laws
- 1262 **B. Cockburn & P-A. Gremaud**, A priori error estimates for numerical methods for scalar conservation laws. Part I: The general approach
- 1263 **R. Spigler & M. Vianello**, Convergence analysis of the semi-implicit euler method for abstract evolution equations
- 1264 **R. Spigler & M. Vianello**, WKB-type approximation for second-order differential equations in C^* -algebras
- 1265 **M. Menshikov & R.J. Williams**, Passage-time moments for continuous non-negative stochastic processes and applications
- 1266 **C. Mazza**, On the storage capacity of nonlinear neural networks
- 1267 **Z. Chen, R.E. Ewing & R. Lazarov**, Domain decomposition algorithms for mixed methods for second order elliptic problems
- 1268 **Z. Chen, M. Espedal & R.E. Ewing**, Finite element analysis of multiphase flow in groundwater hydrology
- 1269 **Z. Chen, R.E. Ewing, Y.A. Kuznetsov, R.D. Lazarov & S. Maliassov**, Multilevel preconditioners for mixed methods for second order elliptic problems
- 1270 **S. Kichenassamy & G.K. Srinivasan**, The structure of WTC expansions and applications
- 1271 **A. Zinger**, Positiveness of Wigner quasi-probability density and characterization of Gaussian distribution
- 1272 **V. Malkin & G. Papanicolaou**, On self-focusing of short laser pulses
- 1273 **J.N. Kutz & W.L. Kath**, Stability of pulses in nonlinear optical fibers using phase-sensitive amplifiers
- 1274 **S.K. Patch**, Recursive recovery of a family of Markov transition probabilities from boundary value data
- 1275 **C. Liu**, The completeness of plane waves
- 1276 **Z. Chen & R.E. Ewing**, Stability and convergence of a finite element method for reactive transport in ground water
- 1277 **Z. Chen & Do Y. Kwak**, The analysis of multigrid algorithms for nonconforming and mixed methods for second order elliptic problems
- 1278 **Z. Chen**, Expanded mixed finite element methods for quasilinear second order elliptic problems II
- 1279 **M.A. Horn & W. Littman**, Boundary control of a Schrödinger equation with nonconstant principal part
- 1280 **R.E. Ewing, Yu.A. Kuznetsov, R.D. Lazarov & S. Maliassov**, Substructuring preconditioning for finite element approximations of second order elliptic problems. I. Nonconforming linear elements for the Poisson equation in a parallelepiped
- 1281 **S. Maliassov**, Substructuring preconditioning for finite element approximations of second order elliptic problems. II. Mixed method for an elliptic operator with scalar tensor
- 1282 **V. Jaksić & C.-A. Pillet**, On model for quantum friction II. Fermi's golden rule and dynamics at positive temperatures
- 1283 **V. M. Malkin**, Kolmogorov and nonstationary spectra of optical turbulence