

MN 2500 AGFO-3296, rev. 190

Maat. 0305

MINNESOTA EXTENSION SERVICE

UNIVERSITY OF MINNESOTA
AGRICULTURE

COMPOSTING AND MULCHING:

A GUIDE TO MANAGING ORGANIC YARD WASTES

AG-FO-3296
Revised 1990

MINNESOTA
EXTENSION SERVICE
MAY 22 1990
PAUL CAMPUS
LIBRARIES

by Carl J. Rosen, Nancy Schumacher,
Robert Mugaas, and Thomas R. Halbach
Department of Soil Science

COMPOSTING AND MULCHING: A GUIDE TO MANAGING ORGANIC YARD WASTES



Composting is a microbial process that converts plant materials such as grass clippings and leaves to a more usable organic soil amendment or mulch. Gardeners have used compost for centuries to increase soil organic matter, improve soil physical properties, and supply some of the essential nutrients for plant growth. *Mulching* refers to the practice of applying a substance such as compost, leaves, or grass clippings to the soil surface with the purpose of modifying soil temperature and moisture as well as controlling weeds and soil erosion.

With the ban on outdoor burning and with laws which prohibit dumping of leaves and grass clippings into landfills, composting and mulching have become attractive alternatives for managing yard waste and recycling natural materials. Grass clippings and leaves can be hauled to city composting areas as one means of disposal. However, many homeowners may find it more convenient and economical to compost these materials in their own backyards. In either case, the finished compost can be used as a mulch or as a soil amendment to improve most garden soils. This bulletin should help you learn how to build and maintain a compost pile as well as how to use the compost in the yard and garden.

Why Compost?

Composting is an efficient method of breaking down organic materials into an end product that is beneficial to the soil and growing plants. Adding organic materials directly to the soil without first composting may initially have some undesirable effects. For example, if large quantities of noncomposted leaves are incorporated into the soil, microbes will compete with plant roots for soil nitrogen during leaf decomposition. This competition for nitrogen can result in nitrogen deficiency and poor plant growth. Adding composted material reduces the competition for nitrogen. Another benefit of composted material is that it is much easier to handle and mix with soil than noncomposted material. Furthermore, improvement of soil physical properties, such as infiltration, drainage, and water holding capacity, will usually be faster if composted materials are added.

Requirements for Efficient Decomposition

Decomposition of organic material in the compost pile is dependent on maintaining microbial activity. Any factor which slows or halts microbial growth will also impede the composting process. Efficient decomposition will occur if the following factors are used to fullest advantage.

Aeration: Oxygen is required for microbes to efficiently decompose the organic wastes. Some decomposition will occur in the absence of oxygen (anaerobic conditions); however, the process is slow and foul odors may develop. Because of the odor problem, composting without oxygen is not recom-

mended in a residential setting unless the process is conducted in a fully closed system (see plastic bag method under "Composting Structures"). Mixing the pile once or twice a month will provide the necessary oxygen and significantly hasten the composting process. A pile that is not mixed may take three to four times longer before it can be used. A well mixed compost pile will also reach higher temperatures which will help destroy weed seeds and pathogens.

Moisture: Adequate moisture is essential for microbial activity. A dry compost will not decompose efficiently. If rainfall is limited, it will be necessary to water the pile periodically to maintain a steady decomposition rate. Enough water should be added to completely moisten the pile, but overwatering should be avoided. Excess water can lead to anaerobic conditions which slow down the degradation process and cause foul odors. Water the pile so that it is damp, but does not remain soggy. Approximately 50-55% moisture on a weight basis is a good starting point.

Particle size: The smaller the size of organic wastes, the faster the compost will be ready for use. Smaller particles have much more surface area that can be attacked by microbes. A shredder can be used before putting material in the pile, and is essential if brush or sticks are to be composted. A low cost method of reducing the size of fallen tree leaves is to mow the lawn before raking. If the mower has an appropriate bag attachment, the shredded leaves can be collected directly. In addition to speeding up the composting process, shredding will initially reduce the volume of the compost pile. The concern for maximum exposed surface area must always be balanced against the requirement for adequate free air space. Particles shredded too small will tend to pack and exclude oxygen.

Nutrients: Microbial activity is affected by the carbon to nitrogen ratio of the organic waste. Because microbes require a certain amount of nitrogen for their own metabolism and growth, a shortage of nitrogen will slow down the composting process considerably. Material high in carbon relative to nitrogen such as straw or sawdust will decompose very slowly unless nitrogen fertilizer is added. Tree leaves are higher in nitrogen than straw or sawdust but decomposition of leaves would still benefit from an addition of nitrogen fertilizer. Grass clippings are generally high in nitrogen and when mixed properly with leaves will enhance decomposition. Manure or blood meal can be used as organic sources of nitrogen. Otherwise, a fertilizer with a high nitrogen containing fertilizer should be used. Other nutrients such as phosphorus and potassium are usually present in adequate amounts for decomposition.

During the initial stages of decomposition organic acids are produced and the pH drops. In the past, small amounts of lime have been suggested for maintaining and enhancing microbial activity at this time. However, high rates of lime will convert ammonium-nitrogen to ammonia gas which will lead to the loss of nitrogen from the pile. Research has

shown that although lime additions may hasten decomposition, the loss of nitrogen from the pile often offsets the benefits of lime (1). In general, lime is not necessary for degradation of most yard wastes. The pH of finished compost is usually slightly alkaline without the addition of lime. In many areas, the water used to moisten the compost pile is alkaline and may also help to increase the pH of the compost. If large quantities of pine needles, spruce needles, or fruit wastes are composted, additional lime may be necessary.

Materials for Composting

Many organic materials are suitable for composting. Yard wastes, such as leaves, grass clippings, straw, and non-woody plant trimmings can be composted. The dominant organic waste in most backyard compost piles is leaves. Grass clippings can be composted; however with proper lawn management, clippings do not need to be removed from the lawn (see below). If clippings are used, it is advisable to mix them with other yard wastes. Otherwise, the grass clippings may compact and restrict air flow. Branches, logs, and twigs greater than 1/4 inch in diameter should be put through a shredder/chipper first. Kitchen wastes such as vegetable scraps, coffee grounds, and eggshells may also be added.

Sawdust may be added in moderate amounts if additional nitrogen is applied. Approximately 1 lb of actual nitrogen (6 cups of ammonium nitrate) is required for 100 lbs of dry sawdust. Wood ashes act as a lime source and if used should only be added in small amounts (no more than 1 cup per bushel). Excessive amounts of wood ashes will result in loss of nitrogen from the pile. Ordinary black and white newspaper can be composted; however, the nitrogen content is low and will consequently slow down the rate of decomposition. If paper is composted, it should not be more than 10% of the total weight of the material in the compost pile. It is recommended that newspaper be recycled through appropriate community paper recycling centers rather than through backyard composting.

Examples of other organic materials that can be used to add nutrients to the pile include: blood and bone meal, livestock manure, and lake plants.

Because they may pose a health hazard, or create a nuisance, certain organic materials should not be used to make compost. Adding human, cat or dog feces cannot be recommended because they may transmit diseases. Meat, bones, grease, whole eggs, and dairy products should not be added because they can attract rodents to the site. Most plant disease organisms and weed seeds are destroyed during the composting process when temperatures in the center of the pile reach 150°–160°F. However, in most compost piles, it is impossible to mix efficiently enough to bring all wastes to the center. Consequently, adding large amounts of weeds with seeds or diseased plants may create problems if the compost is used in the garden.

Although plants that have been treated with herbicides or pesticides should be avoided for composting, small amounts of herbicide-treated plants (e.g., grass clippings) may be mixed in the pile as long as one is careful to allow thorough decomposition. Ideally, clippings from lawns recently treated with herbicides should be left on the lawn to decompose (see section on *Alternatives to Composting Grass Clippings*).

Most agrichemicals, both pesticides and herbicides, are degraded at varying rates. A list of common chemicals used on the home lawn and their degradation rate in soil is provided in **Table 1**. Even if some treated grass clippings are used, the degradation of these chemicals in a properly maintained compost pile should be at least as fast as that in the soil.

Composting Structures

To save space, hasten decomposition, and keep the yard looking neat, it is recommended that the compost pile be contained in some sort of structure. Composting structures can consist of a variety of materials and made as simple or complex as desired. There are many options available that can be tailored to individual needs. Listed below are a few suggestions for containing the compost.

Use of plastic garbage bags is perhaps the simplest way to make compost. The bags are easy to handle, and require minimal maintenance. To make compost using this method, 30-40 gallon plastic bags should be alternately filled with plant wastes, fertilizer and lime. About one tablespoon of a garden fertilizer with a high nitrogen content should be used per bag. Lime (one cup per bag) helps counteract the extra acidity caused by anaerobic composting. After filling, add about 1-2 quarts of water. Dry material may require more than this quantity of water. Close tightly. Set aside for six months to a year. Bags can be set in a basement or heated garage for better decomposition during winter months. Using garbage bags requires no turning or additional water after closing. The main advantage of composting in garbage bags is that it requires little maintenance; however, because oxygen is limited, the process is slow.

A barrel or drum composter generates compost in a relatively short period of time and provides an easy mechanism for turning (**Figure 1**). This method requires a barrel of at

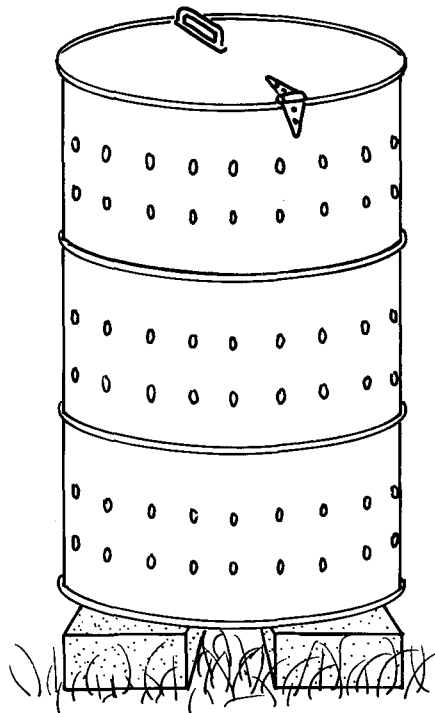

Figure 1

least 55 gallons with a secure lid. Be sure that the barrel was not used to store toxic chemicals. Drill 6-9 rows of 1/2 inch holes over the length of the barrel to allow for air circulation and drainage of excess moisture. Place the barrel upright on blocks to allow bottom air circulation, and fill it 3/4 full with organic waste material and about one quarter cup of a high nitrogen containing fertilizer. If needed apply water until moist. Every few days, turn the drum on its side and roll it around the yard to mix and aerate the compost. The lid can be removed after turning to allow for air penetration. Ideally, the compost should be ready in two to four months. The barrel composter is an excellent choice for the city dweller with a relatively small yard.

For larger quantities of organic waste, bin-type structures are the most practical. As an example, a circular bin can be made by using a length of small spaced woven wire fencing and holding it together with chain snaps (*Figure 2*). The bin should be about three to five feet in diameter and at least four feet high. A stake may be driven in the middle of the bin before adding material to help maintain the shape of the pile and to facilitate adding water. With this design, it is easiest to turn the composting material by simply unsnapping the wire, moving the wire cylinder a few feet, and turning the compost back into it.

A very efficient and durable structure for fast composting is a three-chambered bin (*Figure 3*). It holds a considerable amount of compost, and allows good air circulation. The three-chambered bin works on an assembly line idea, having three batches of compost in varying stages of decomposition. The compost material is started in the first bin and allowed to heat up for 3-5 weeks. Next, it is turned into the middle bin for another 4-7 weeks, while a new batch of material is started in the first bin. Finally, the material in the middle bin is turned into the last bin as finished or nearly finished compost.

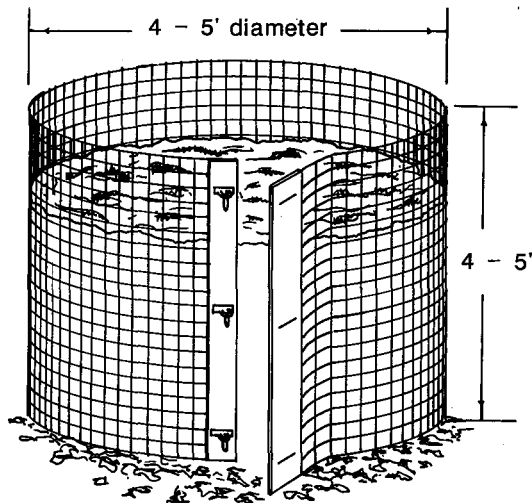

Figure 2

To make this structure, it is best to use rot resistant wood such as redwood or cedar, or a combination of wood and metal posts. Unless the wood is treated or rot resistant, it will decompose within a few years. Each bin should be about five feet by three feet and about three to five feet high. Using removable slats in the front offers complete access to the contents for turning.

There are many other structures for composting, and no one structure is best. Invent your own, or for a more thorough description of different structures, refer to Rodale's *Complete Guide to Composting* (3). If you don't want to build a structure, there are several commercial composting units available through local garden stores or mail-order catalogues. Most of these are similar to the barrel composter described previously and are for the city dweller who desires an easy method to make small amounts of compost quickly.

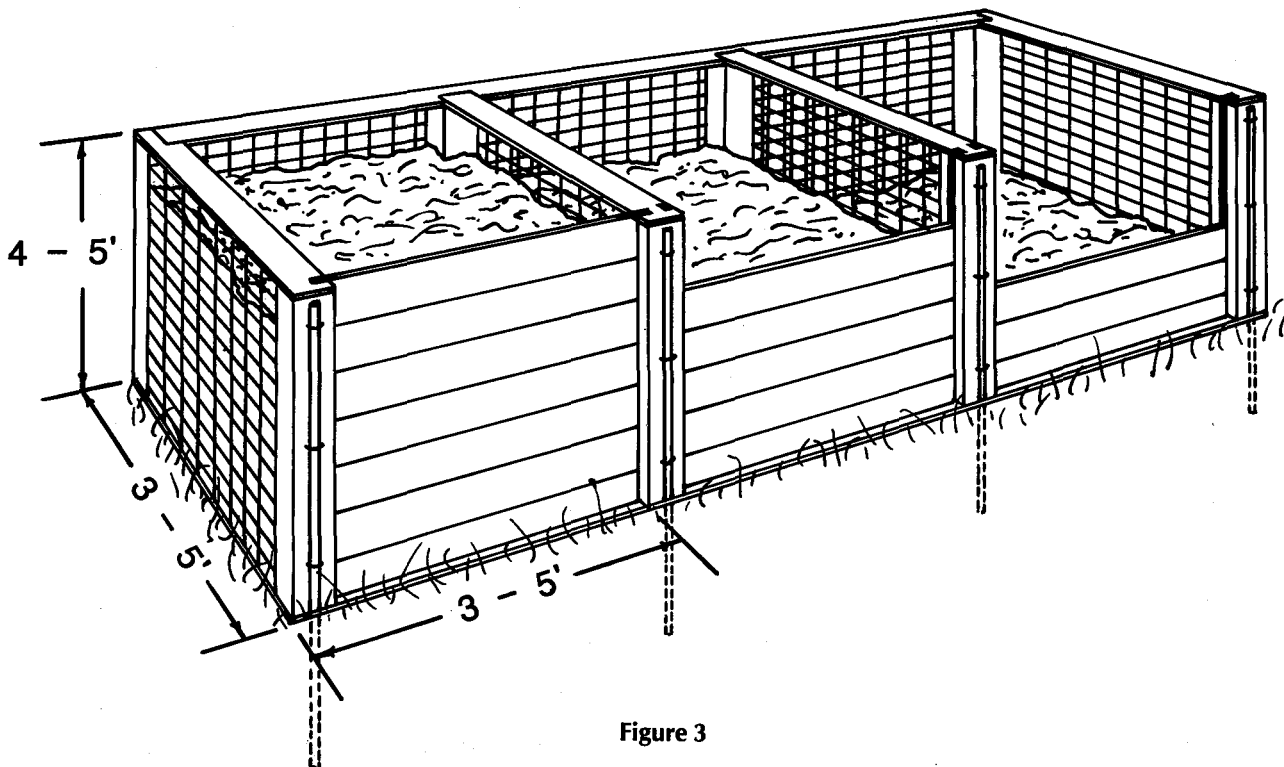

Figure 3

Location

The compost pile should be located close to where it will be used and where it will not interfere with activities in the yard or offend neighbors. Examples of good locations for the pile include: near the garden or kitchen, or between the garage and house. The pile will do best where it is protected from drying winds and in partial sunlight to help heat the pile. The more wind and sun the pile is exposed to, the more water it will need.

Preparing the Compost Pile

The compost pile should initially be prepared in layers. This will facilitate decomposition by insuring proper mixing. An example of the layering process is illustrated in **Figure 4**. Each pile ideally should be about 5 feet high.

Organic wastes, such as leaves, grass, and plant trimmings are put down in a layer eight to ten inches deep. Coarser materials will decompose faster if placed in the bottom layer. This layer should be watered until moist, but not soggy. A nitrogen source should be placed on top of this layer. Use one to two inches of livestock manure, or a nitrogen fertilizer such as ammonium nitrate or ammonium sulfate at a rate of one third of a cup for every twenty five square feet of surface area. If these nitrogen sources are not available, one cup of 10-10-10 fertilizer per 25 square feet of surface area will also suffice. Do not use fertilizer that contains herbicide or pesticide. Other organic sources of nitrogen that can be used are green grass clippings, lake plants, or blood meal. Grass clippings tend to mat and should either be mixed well with other materials, such as wood chips or leaves, or placed in layers only one to two inches thick.

About a one inch layer of soil or completed compost can be applied on top of the fertilizer layer. One purpose of adding soil is to ensure that the pile is inoculated with decomposing microbes. The use of soil in a compost pile should be considered optional. In most cases, organic yard wastes such as grass clippings or leaves contain enough microorganisms on the surface to effect decomposition. Studies have shown that there is no advantage in purchasing a compost starter or inoculum. Microbes multiply as rapidly from the soil and/or added organic wastes as from the inoculum. Those microbes already in the soil and on organic materials are just as efficient in decomposing the waste as those provided by the commercial inoculum. Adding soil, however, will help reduce leaching of mineral nutrients such as potassium released during decomposition. Repeat the sequence of adding organic waste, fertilizer, and soil (optional) until the pile is completed, remembering to water each section.

The carbon:nitrogen (C/N) ratio will determine how long decomposition will take. An initial C/N ratio of about 25 to 30 is needed for rapid composting. If the initial C/N ratio is above 50, the process will be considerably slower. The C/N ratio of common organic yard wastes is provided in **Table 2**. Materials can be blended and mixed to achieve an initial C/N ratio of 25 or 30. Over time, the C/N ratio will generally decrease.

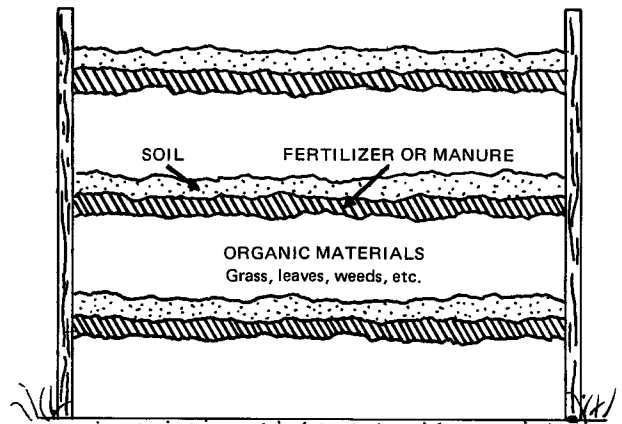

Figure 4

Maintaining the Compost Pile

To prevent odors and hasten decomposition, the pile must be turned occasionally. Turning also exposes seeds, insect larvae, and pathogens to lethal temperatures inside the pile. Turning may be done by inverting segments of the compost, or by shifting the pile into another bin. The compost pile should be kept moist but not waterlogged. Odors may arise either from the addition of excessive amounts of wet plant materials like fruits or grass clippings, or from overwatering. A properly mixed and adequately turned compost heap will not have objectionable odors. An actively decomposing pile will reach temperatures of 130° - 160°F in the middle. Reasons for the pile not heating up may be due to: Too small a pile, not enough nitrogen, lack of oxygen, too much moisture or not enough moisture. The pile should be turned when the temperature in the center begins to cool. This will introduce oxygen and undecomposed material into the center and subsequently regenerate heating. The composting process is essentially complete when mixing no longer produces heat in the pile.

Small amounts of fresh materials may be added provided that the pile is occasionally turned. Vegetable wastes should be buried inside the pile to avoid attracting rodents. If enough material is available, it is best to make a new pile instead of combining with old compost.

Generally, a well managed compost pile with shredded materials under warm conditions will be ready in about 2-4 months. A pile left unattended and material not shredded may take over a year to decompose. Piles prepared in the late fall will not be ready for use the following spring. When the compost is finished, the pile will be about half its original size and have an earthy smell to it.

Table 1. Persistence of herbicides in soil (2)

Common Name	Trade Names	Persistence in Soil
		(months)
Benfin	Balan, Balfin	4-8
DCPA	Dacthal	4-8
Bensulide	Betasan, Prefar	6-12
Glyphosate	Roundup, Kleenup	Less than 1
2,4-D	(Many Formulations)	1-2
MCPP	(Many Formulations)	1-3
Dicamba	Banvel	3-12

Table 2. Approximate concentration of nitrogen and carbon to nitrogen (C/N)* ratio of various materials used in municipal and backyard composts (4)

Material	Nitrogen % dry weight	C/N ratio wt/wt
Grass clippings	2.15	20
Leaves	0.5 - 1.0	40-80
Sawdust	0.11	511
Wood	0.07	400-800
Fruit wastes	1.52	35
Paper	0.25	170
Table scraps	-	15
Livestock manure	-	10-12

* See text for further explanation.

Municipal Composting of Yard Wastes

If building your own compost heap is impractical, there are municipal composting sites available in many counties for disposal of leaves and grass clippings. Depending on the location, leaves only or leaves and grass clippings may be dropped off at the composting sites. Some city compost programs also have curbside pick-up in the fall. Completed compost is also available free of charge from these sites. For information on the nearest composting site, contact your local county extension agent.

In the past there has been some concern about using municipal waste compost because of contamination with lead and

other trace metals. Possible modes of yard waste contamination may be due to direct exposure of leaves and grass to automobile exhaust or to inclusion of street sweepings (which might contain high levels of lead from automobile exhaust) in the compost pile. A study at the University of Minnesota (5), characterized elemental composition of yard waste composts from 11 different sites in the seven-county metropolitan area. The mean and ranges of elemental concentrations in the compost piles over two years are presented in Table 3. There was a wide range in lead values from the different sites. The highest concentrations were found in composts produced at sites in the most urban areas. Generally it has been considered safe to use garden produce grown

**Table 3. Chemical Characteristics of Municipal Yard Waste Composts
Mean of 11 compost sites over 2 years (5)**

	Concentration (dry weight basis)	
	Mean	Range
Carbon %	19.3	4.4-41.4
Nitrogen %	1.3	0.3-4.2
Carbon/Nitrogen*	15.4	11-25
Phosphorus %	0.19	0.05-0.5
Potassium %	0.39	0.04-2.71
Calcium %	3.02	0.70-8.04
Magnesium %	0.54	0.09-1.34
Iron %	0.25	0.06-0.31
Aluminum %	0.27	0.06-0.31
Manganese mg/kg**	420	223-1261
Sodium mg/kg	154	36-921
Zinc mg/kg	88	39-585
Copper mg/kg	11	3-143
Boron mg/kg	41	7-141
Lead mg/kg	49	1-380
Cadmium mg/kg	0.4	<0.1-1.4
Chromium mg/kg	6.3	1.2-52.5
Nickel mg/kg	7.3	1.7 - 33.3
pH	7.6	4.5-8.3

Samples for metal analysis were dry ashed and resuspended in 2N HCl. Metals were determined using an inductively coupled plasma spectrometer.

* Ratio of carbon to nitrogen (See text for further explanation).

< means "less than."

**mg/kg=milligrams per kilogram, which is the same as parts per million

in soils with total lead levels less than 500 mg/kg (parts per million). The lead levels in the yard waste composts are considerably less than this suggested limit. Other trace metals such as cadmium, nickel, copper, chromium, and zinc are also present in compost in small quantities. The Minnesota Pollution Control Agency has established maximum concentrations of these elements for composts that are applied to soil. The allowable levels in milligrams per kilogram on a dry weight basis are:

<i>Cadmium</i>	10
<i>Nickel</i>	100
<i>Copper</i>	500
<i>Chromium</i>	1000
<i>Zinc</i>	1000

Typical concentrations of these elements found in municipal yard waste composts are many times less than the allowable levels. If you are concerned about the composition of the municipal compost, ask the operators if a recent chemical analysis is available.

Use of Compost as a Soil Amendment

Compost is used as an organic amendment to improve physical, chemical, and biological properties of soils. Adding compost will increase the moisture holding capacity of sandy soils, thereby reducing drought damage to plants. When added to heavy clay soils, compost will improve drainage and aeration, thereby reducing waterlogging damage to plants. Compost will increase the ability of the soil to hold and release essential nutrients. The activity of earthworms and soil microorganisms beneficial to plant growth will be promoted with compost additions. Other benefits of adding compost include improved seed emergence and water infiltration due to a reduction in soil crusting.

Over time, yearly additions of compost will create desirable soil structure, making the soil much easier to work. For improving soil physical properties, add and incorporate 1 - 2 inches of well decomposed compost in the top 6 - 8 inches of soil. Use the lower rate for sandy soils and the higher rate for clay soils.

To a limited extent, compost is a source of nutrients. However, nutrient release from compost is slow and the nutrient content is often too low to supply all the nutrients necessary for plant growth. As noted in Table 3, there is a wide variation in nutrient content of municipal leaf compost. Differences are probably due to several factors including age of the compost, amount of water added, plant species, and the amount of soil that becomes mixed into the pile during turning.

It is usually necessary to supplement compost with some fertilizer, particularly nitrogen. If the C/N ratio of the compost is less than 20 to 1, nitrogen will tend to be released rather than tied up (5). For the majority of municipal yard waste composts, the C/N ratio is less than 20 to 1 (Table 3). Thus, while composts may not supply significant amounts of nitrogen, especially in the short run, nitrogen tie-up should not be a major concern with most yard waste composts. Approximately 1 cup of ammonium nitrate (0.15 lb actual nitrogen) per 3 bushels (100 lbs compost) is required to provide the additional nitrogen needed by most garden plants.

Have your soil tested every few years to determine whether supplemental phosphorus and potassium are required. The pH of most yard waste composts is usually between 7.0 and 8.0. This slightly alkaline pH of compost should not pose any problems when diluted by mixing into the soil and in fact is beneficial to plants growing on acid soils. Because of the alkaline pH, yard waste composts do not appear well suited for use on acid loving plants such as azaleas and blueberries.

Use of Compost in Potting Soils

Leaf compost can be used as a component of potting mixes. Generally, no more than one quarter to one third by volume of the potting mix should be compost, because over time some of the compost is likely to decompose and the volume of the potting soil will be reduced. In addition, high levels of compost in a mix may cause waterlogging and poor aeration for roots.

Although proper composting destroys most weed seeds and disease organisms, some may still survive due to incomplete mixing. To obtain a completely pasteurized leaf compost, it is necessary to heat the material in an oven until the temperature of the center reaches 160°F and is maintained for 30 minutes.

Use of Compost as a Mulch

Mulches are used in gardens to suppress weeds, reduce soil erosion, modify the soil temperature (cooler in the summer, warmer in the winter), and conserve soil moisture. Yard waste compost makes an ideal mulch for annual and perennial gardens. All that needs to be done is to apply a 3 - 6 inch layer of compost around the base of the plant. Periodically throughout the summer, you may need to add more compost over the old layers to maintain the benefits of the mulch.

The soil environment beneath the mulch is favorable for promoting earthworms which in turn are valuable for aerating the soil. Organic matter is gradually added to the soil as the mulch decomposes. For annual gardens, the mulch can be worked into the soil at the end of the season to further improve soil physical properties. For perennials, it may be beneficial to remove the mulch in the spring to allow the soil to thaw out faster. As discussed above, a well decomposed yard waste compost will not tie up nitrogen. Therefore, additional nitrogen beyond that recommended for plant growth is unnecessary. If uncomposted or partially composted leaves are used, one tablespoon of a high nitrogen fertilizer should be applied to each bushel of mulch.

Alternatives to Composting Grass Clippings

When proper lawn management is used, there is no need to collect grass clippings (6). The question of whether to collect or not to collect grass clippings has been around for a long time. However, it is now agreed that as long as the grass is not excessively long and clippings do not thickly cover the lawn surface after mowing, there is normally no need to collect the clippings. Aside from reducing the work involved in lawn maintenance, leaving the grass clippings benefits the turf by returning nutrients and organic matter to the

soil. If evenly distributed, clippings left on the lawn can be equivalent to one fertilizer application per year.

In order to keep your lawn looking healthy and to control the amount of clippings generated, several maintenance practices should be followed. It is important that mowing height be properly adjusted. The height of the cut will depend on the turfgrass varieties present in the lawn and whether the lawn is in sun, full shade, or a combination of both. Lawns in full sun have the greatest potential for quick recovery after mowing and can therefore be cut shorter. Those in the shade need all the available leaf surface possible for photosynthesis. Thus, grass in the shade should be cut slightly higher than grass in the sun. Where both conditions are present, an intermediate height is recommended. Some suggested mowing heights are listed below:

<i>Fine Fescue</i>	1-1/2 to 3 inches
<i>Kentucky bluegrass/perennial ryegrass</i>	1 to 2 inches
<i>Kentucky bluegrass:</i>	
<i>Improved varieties</i>	3/4 to 2 inches
<i>Common types</i>	1-1/2 to 2-1/2 inches
<i>Kentucky bluegrass/red fescue</i>	1-1/2 to 2-1/2 inches

Mowing frequency also has a direct impact on the amount of clippings generated. Mowing frequency depends on the cutting height selected and how fast the turf grows rather than on specific time intervals such as once per week, etc. Ideally, no more than one third of the leaf surface area should be cut at any one time and the clippings should be no longer than one inch. As an example, a lawn with grass three inches tall should be cut to about two inches. Excessive defoliation in a single mowing can make the lawn more prone to stress and disease problems.

Be careful not to over-fertilize your lawn. Over fertilization (primarily nitrogen) will cause excessive growth and unless the lawn is cut more frequently, the clippings will be slow to reach the soil and decompose. Reducing excessive thatch levels through lawn renovation will improve infiltration of the grass clippings down to the soil surface. It is best to mow your lawn when it is dry so clippings will be able to filter down to the soil without clumping. For more information on lawn fertilization and lawn care, contact your local county extension office.

Two types of mowers available to homeowners are reel and rotary. Either will do an acceptable job when sharpened and adjusted properly. Mower blades should always be kept sharp, as dull blades can result in deterioration of the lawn area. Rotary mowers are now available with a mulcher attachment for the blade. This will reduce the size of the clippings left behind and should result in faster decomposition of the grass blades. However, if you are mowing on a regular basis and not removing more than one third of the grass blades at a time, additional size reduction is not necessary.

If grass growth is excessive it may become necessary to remove the clippings. In this situation, lawn clippings can be used in the compost pile as described above or they can be used as a mulch in the garden. If used as a mulch, care should be taken not to over apply fresh clippings as they tend to inhibit moisture and oxygen penetration into the soil, and may produce offensive odors. Mixing fresh clippings with compost provides an excellent mulching material. Do not use grass clippings as a mulch if the lawn has recently been treated with herbicides. Where herbicides have been applied, it is recommended that the clippings be left on the lawn for at least 3 mowings.

References

1. *Reclamation of Municipal Refuse by Composting*. 1953. University of California, Berkeley, Tech. Bull. No. 9, Series 37, Sanitary Engineering Research Project.
2. Van Der Puy, D., *Characteristics of Herbicides Used in Agronomic Crops*. 1985. North Dakota Cooperative Extension Service Bulletin #W-871.
3. Rodale, J.I. *The Complete Guide to Composting*. 1971. Rodale Books, Inc. Erasmms, PA, 9th printing.
4. *Biochemical and Microbiological Aspects of Composting*. 1974. Connecticut Agricultural Experiment Station Bulletin 754.
5. Schumacher, Nancy, M. DuBois, M. Martindale, C.E. Clapp, J.A.E. Molina. *Composition of Yard Waste Composts Produced at Twin Cities Metropolitan Area Centralized Composting Sites*. Research report submitted to the Legislative Commission for Minnesota Resources, 1987, Attachment D. The State Office Building, St. Paul, MN.
6. Allen, P. and D. White. 1990. *Lawn Clipping Management*. Minnesota Extension Service. AG-FO-3915.

About the Authors

Carl Rosen Extension Soil Scientist, Minnesota Extension Service; *Nancy Schumacher*, Former Assistant Scientist, Department of Soil Science, University of Minnesota; *Robert Mugaas*, Extension Agent, Hennepin County, Minnesota Extension Service, and *Thomas Halbach*, Assistant Extension Specialist, Waste Management. Editor: *Phyllis Petersen*, Educational Development System, Minnesota Extension Service.

This project was supported by a grant from the Metropolitan Council, 300 Metro Square, 7th and Robert Streets, St. Paul, MN 55101.

The information given in this publication is for educational purposes only. No discrimination is intended and no endorsement by the Minnesota Extension Service is made.

Issued in furtherance of cooperative extension work in agriculture. The University of Minnesota Extension Service, in cooperation with the U.S. Department of Agriculture, is committed to the policy that all persons shall have equal access to its programs, services, and activities, regardless of race, sex, age, national origin, or sexual orientation.

UNIVERSITY OF MINNESOTA



3 1951 D00 374 106 S

No discrimination is made with the understanding that no discrimination

is intended and no endorsement by the Minnesota Extension Service is made. Issued in furtherance of cooperative extension work in agriculture, in cooperation with the U.S. Department of Agriculture, Minnesota, including the Minnesota Extension Service, is committed to the policy that all persons shall have equal access to its programs, services, and activities, regardless of race, sex, age, national origin, handicap, age, veteran