

Library, New Mexico State College
The University of Minnesota

AGRICULTURAL EXPERIMENT STATION
BULLETIN 135

WOODWORKING EXERCISES
FOR THE
AGRICULTURAL SCHOOL SHOP

BY
HALL B. WHITE

DIVISION OF AGRICULTURAL ENGINEERING



UNIVERSITY FARM, ST. PAUL
JULY 1913

THE UNIVERSITY OF MINNESOTA

THE BOARD OF REGENTS

The HON. JOHN LIND, Minneapolis, President of the Board	-	1914
GEORGE EDGAR VINCENT, Minneapolis	- - - - -	<i>Ex-Officio</i>
The President of the University		
The HON. ADOLPH O. EBERHART, Mankato	- - - - -	<i>Ex-Officio</i>
The Governor of the State		
The HON. C. G. SCHULZ, St. Paul	- - - - -	<i>Ex-Officio</i>
The State Superintendent of Public Instruction		
The HON. JOHN G. WILLIAMS, Duluth	- - - - -	1914
The HON. A. E. RICE, Willmar	- - - - -	1915
The HON. CHARLES L. SOMMERS, St. Paul	- - - - -	1915
The HON. B. F. NELSON, Minneapolis	- - - - -	1916
The HON. PIERCE BUTLER, St. Paul	- - - - -	1916
The HON. FRED B. SNYDER, Minneapolis	- - - - -	1916
The HON. W. J. MAYO, Rochester	- - - - -	1919
The HON. MILTON M. WILLIAMS, Little Falls	- - - - -	1919

THE AGRICULTURAL COMMITTEE

The HON. A. E. RICE, Chairman	The HON. MILTON M. WILLIAMS
The HON. C. G. SCHULZ	President GEORGE E. VINCENT
The HON. JOHN G. WILLIAMS	

STATION STAFF

A. F. WOODS, M.A., Director
J. O. RANKIN, M.A., Editor
HARRIET E. SEWALL, B.A., Librarian
T. J. HORTON, Photographer

T. L. HAECKER, Dairy and Animal Husbandman
M. H. REYNOLDS, B.S.A., M.D., D.V.M., Veterinarian
ANDREW BOSS, Agriculturist
F. L. WASHBURN, M.A., Entomologist
E. M. FREEMAN, Ph.D., Plant Pathologist and Botanist
JOHN T. STEWART, C.E., Agricultural Engineer
R. W. THATCHER, M.A., Agricultural Chemist
F. J. ALWAY, Ph.D., Soils Chemist
LEROY CADY, B.S. in Agr., Horticulturist
E. G. CHEYNEY, B.A., Forester
A. D. WILSON, B.S. in Agr., Superintendent of Agricultural Extension
L. H. D. WELD, Ph.D., Agricultural Economist
A. J. MCGUIRE, B.Agr., Superintendent, Grand Rapids Substation
E. C. HIGBIE, M.A., Superintendent, Morris Substation
C. G. SELVIG, M.A., Superintendent, Crookston Substation
CHARLES HARALSON, Superintendent, Fruit Breeding Farm, Excelsior

Division of Agricultural Engineering

JOHN T. STEWART, C.E., Agricultural Engineer
JASON L. MOWRY, Mechanics
HARRY B. ROE, B.S. in Eng., Mathematics
ALVAH M. BULL, Farm Structures
HALL B. WHITE, B.S. in Agr., Carpentry
JENNESS B. FREAR, M.E., Mechanics Laboratory
ADDISON L. EWING, M.S., Physics
ALLEN D. JOHNSTON, Blacksmithing
LLOYD R. WHITSON, E.M., Drawing
LYDIA M. GORMAN, Clerk and Computer
GEORGE F. KROGH, Draftsman

LETTER OF TRANSMITTAL

MINNESOTA AGRICULTURAL EXPERIMENT STATION,
DIVISION OF AGRICULTURAL ENGINEERING,
University Farm, St. Paul, Minnesota, March 17, 1913.

A. F. WOODS,
*Director, Minnesota Agricultural Experiment Station,
University Farm, St. Paul.*

DEAR SIR: I hereby transmit a manuscript entitled "Woodworking Exercises for the Agricultural School Shop," which is recommended for publication as Minnesota Agricultural Experiment Station Bulletin No. 135.

The manuscript has been prepared under my direction by Hall B. White, Instructor in charge of Carpentry in the Department of Agriculture at University Farm. The photographs were taken by T. J. Horton, Station Photographer, and the drawings made by George F. Krogh, Draftsman in this Division.

The object in requesting the publication of this material as a bulletin is to meet the demand throughout the State for exercises suitable for carpentry work wherein the dimensions are plainly given.

This manuscript is not intended to be a complete treatise on the subject of woodwork, as numerous publications are already in print on this subject. The object is to furnish information to those desiring to work along these lines who do not know where to look for the necessary information. Consequently the descriptive matter is practically limited to lists and tabulated information, the greater part of the manuscript consisting of drawings and photographs showing the exact measurements of thirty exercises suitable for class work.

It is believed the manuscript as prepared will supply information for which there has been a large call by young men who have had a limited amount of instructional work in carpentry. Since woodworking machinery is not adapted to the farm school carpentry shop, exercises requiring the use of machinery have been intentionally omitted.

Respectfully submitted,
JOHN T. STEWART,
Chief, Division of Agricultural Engineering.

WOODWORKING EXERCISES

FOR THE

AGRICULTURAL SCHOOL SHOP

INTRODUCTION

The increased use of machinery in farm operations has made it necessary for the farmer to make repairs and attachments that will prolong the life or add to the effectiveness of his equipment. To do this economically there must be an understanding of the use and care of tools. It is in response to this need that many schools are giving courses in shop work. When farm boys have an opportunity to do repair work with proper tools, they soon acquire skill in doing it. The ability to do repairing and to understand mechanical operations adds interest to farm work and also adds greatly to the conveniences for doing it. Furthermore, it often enables the boys to take advantage of more complicated tools and machinery and to get the best results from them.

FARM SHOP AND WORK-BENCH

It is not necessary to have a separate building for doing the repair work although this would be very desirable. Often a corner or part of the machine shed makes a satisfactory place, as the machinery can be repaired during stormy days while under shelter.

A plan is shown of a work-bench that is large enough for almost any farm. It is very satisfactory to work at, as it is firm and provides plenty of room. The tools are to be hung along the wall or placed in cases on the wall. A window above the bench, opposite the vise, is desirable.

For a smaller bench that can be taken to the place where repairs are necessary, the farmers' work-bench will be found convenient. Although small, it has room for locking up the tools when they are not in use.

Farmers' Bulletin 347, published by the United States Department of Agriculture, Washington, D. C., gives directions for the arrangement of a shop building and equipment.

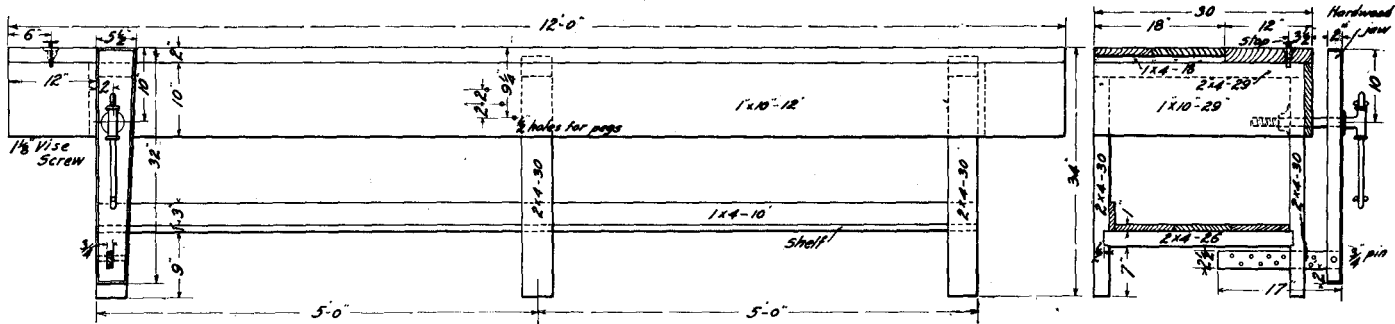

Note: To be fastened to wall.

WORK-BENCH

Material: Pine

Pieces	Thickness	Width	Length
	Inches	Inches	Feet
1	2	12	12
1	1	10	12
1	1	10	12
1	1	8	12
1	1	4	10
3	1	8	10
2	1	10	29†
3	1	4	18†
6	2	4	30†
3	2	4	29†
3	2	4	26†
1*	2	6	32†
1	3/4	2 1/2	17†

*Hardwood
†Inches

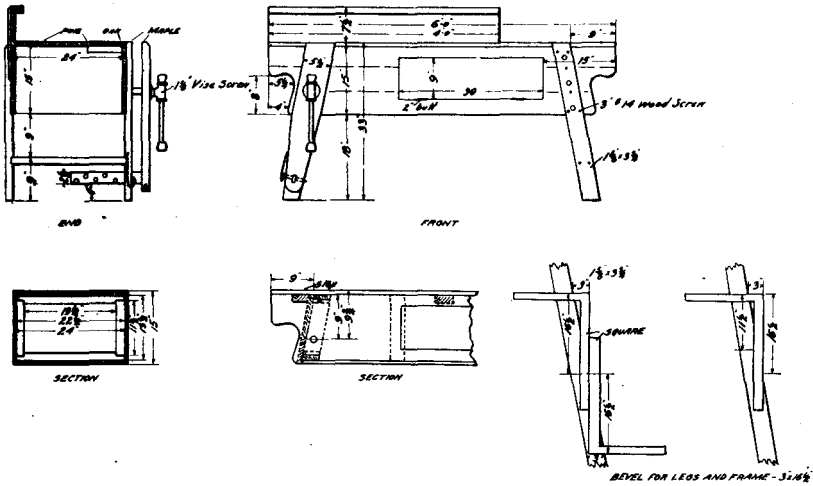

FARMERS' WORK-BENCH

Material: Pine; (1) Maple; (2) Oak; (3) Dressed and matched

Pieces	Thickness	Width	Length
	Inches	Inches	Inches
5	2	4	22½
4	2	4	13
2	2	4	24
3	2	4	36
(1) 2	2	6	36
1	1	7½	48
1	1¼	1½	48
1	1	9	30
(1) 1	¾	2½	17
2	¾	2	16
(2) 1	1	6	72
(3) 26	1	4	72

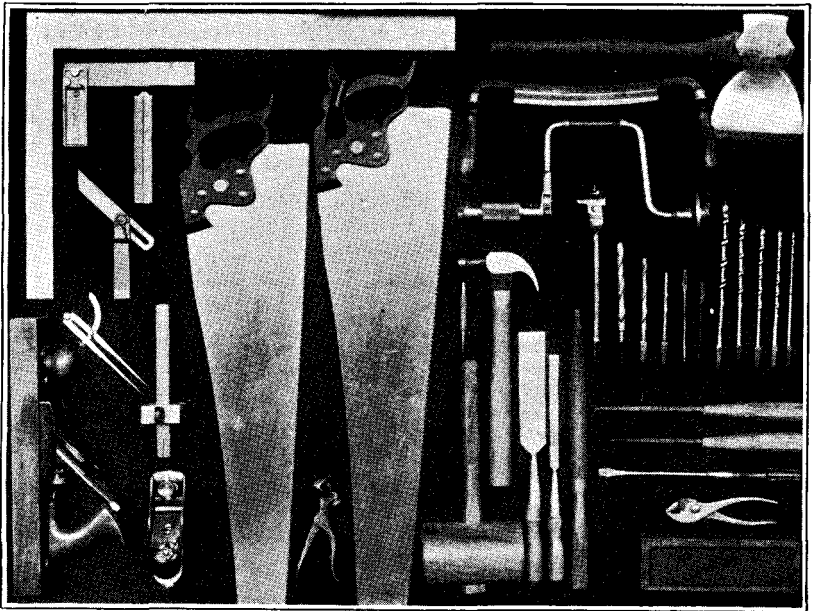

TOOLS FOR FARM SHOP

Rip saw, 28 in., 5½ pts.	\$1.75
Hand saw, 26 in., 8 pts.	1.75
Jack plane, 15 in., 2¼ in. cutter.	1.25
Block plane, 6 in.	1.00
Hammer, 1 lb.60
Framing square, No. 100	1.25
Try square, 6 in.40
Expansive bit, ⅞ to 3 in.	1.00
Bits, ¼, ⅜, ½, ⅝ and ¾ in.	1.25
Ratchet brace, 10 in.	1.50
Twist drills, ¼, ⅝, ⅜ and ½ in.	1.00
Socket firmer chisels, ½ and 1½ in.	1.00
Mallet, mortised handle.25
Drawknife, 8 in.75
Screwdriver, 6 in.50
Dividers, 6 in.25
Saw set75
Marking gauge15
Oilstone, 1x2x7	1.00
Rule, 2 ft.25
Wood rasp, 10 in. half round.50
Saw vise75
Hand axe75
Nail set10
Sliding T bevel25
Gimlets, No. 5 and No. 7.15
Pliers, 6 in.75
Files, 5 in. and 6 in. slim taper.20

ADDITIONAL TOOLS

If it is desirable to make up some of the more complicated articles shown on the following pages, it is necessary to have additional tools, such as clamps, scraper, spokeshave, fore plane, rabbet plane, and countersink.

QUALITY OF TOOLS

It pays to buy tools of good quality. In most cases their usefulness and length of life are determined by the material used in making them. The name of a manufacturer with an established reputation for making good tools is usually a guaranty of good quality. If the dealer sells a new brand, it is desirable that either he or the manufacturer stand ready to replace defective tools. Cheap tools of inferior quality are usually a disappointment to the purchaser.

• CARE OF TOOLS

Oil will need to be used on many of the bright tools to prevent rusting.

It is important to keep all edge tools sharp that the work may be accomplished with ease and accuracy. An edge satisfactory for most work can be procured by holding the tool on a grindstone or grinder in such a position as to form a bevel of twenty-five degrees, and then whetting on an oilstone at an angle of thirty-five degrees.

Each tool should have its place and should be returned to it when a job is finished. A good way to insure the return of tools is to draw an outline of them on the wall, then paint in the space with black paint.

MATERIALS

Ash is suitable for use in making such articles as tool chests and butter workers. It resembles oak somewhat but is not so strong. It works easily. Brown ash is commonly carried by dealers in hardwood.

Filler is pastelike material used for filling the pores of open-grained woods like ash and oak. It gives a smooth surface on which to apply varnish or wax. It can be obtained at paint or hardware stores. Directions are given on the can as to the method of using.

Hickory is the hardest, toughest wood in common use. Second growth is tougher and hence more desirable for handles. It is too hard to be nailed. It costs about as much as oak and is carried in stock by dealers in hardwood.

Oak is one of the best woods for cabinet work. There are two kinds used—white and red. White is the stronger and more valuable but is harder to work. Quarter-sawed oak costs more but is desirable

for many uses, such as table tops. For the best work, oak should be kiln-dried. Hardwood dealers carry oak, as there is a considerable demand for it.

Paint is a protective covering of oil, white lead, zinc oxide, colors, etc., which conceals the surface it beautifies. Directions are given on the cans. It can be obtained at paint, hardware, or drug stores.

White pine is the one of many varieties of pine which is the most desirable for woodworking exercises. It can be obtained from dealers who carry a complete line of softwood lumber. It takes paint well or may be finished nicely with shellac.

Raw linseed oil is used for finishing hammer handles and similar work. It is very durable when worked into the wood by brisk rubbing with the bare hand.

Shellac varnish is used in work where quick drying is an advantage and should be applied with as little brushing as possible. It is best kept in a glass bottle or a fruit jar with a hole through the cover for the brush. A sheet of rubber with a small hole in it through which the handle is thrust and which makes a tight fit on the handle will prevent evaporation. Shellac is carried in stock by all paint dealers.

Stain is a coloring matter dissolved in oil, alcohol, or water, used to beautify wood. Many different colors can be obtained. It is very satisfactory for small pieces of woodwork and often nothing is applied but a coat of stain and one of wax.

Varnish is either a transparent resin or a gum dissolved in oil or spirits and is used on high-grade work, such as tables and pianos. Be sure it is dry before handling. Directions are given on cans. See catalogue of paints and varnishes for different grades.

Wax already prepared can be obtained from dealers who carry paints. It is used on many pieces where a dull finish is desired. It is applied by a cloth or waste and after fifteen minutes can be polished with a soft cloth or clean waste.

SELECTION OF EXERCISES

It is believed that the first six exercises can be used for class work in the order shown. The remaining exercises have proved satisfactory, and selection can be made according to the student's ability and the material at hand. The student should make a careful study of the exercise before he begins to get out his material. The dimensions given in the list of pieces are for finished size except for the first six exercises and the drawing board.

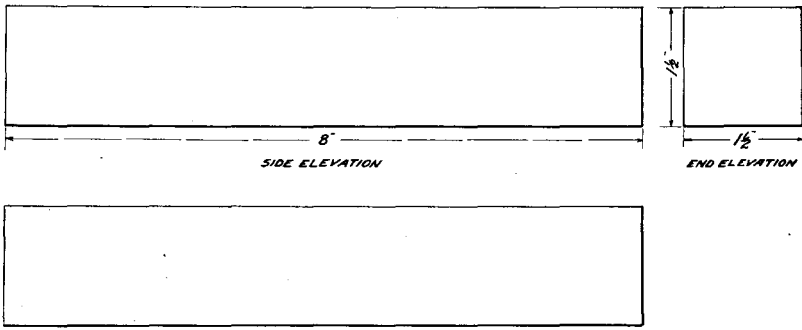
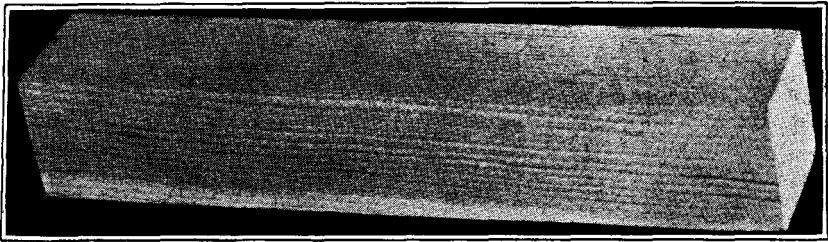

1. "SQUARING-UP" EXERCISE

Gives practice in squaring and working to line

Material: Pine

Pieces	Thickness	Width	Length
1	Inches 15/8	Inches 15/8	Inches 8 1/2

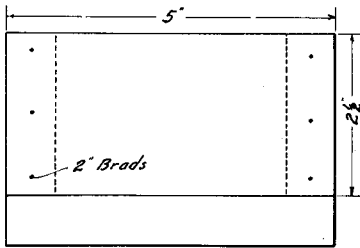
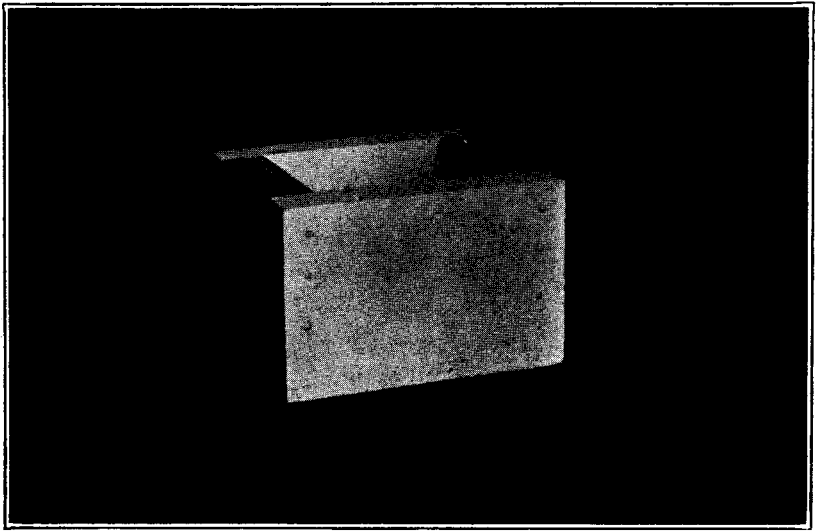

SIDE ELEVATION

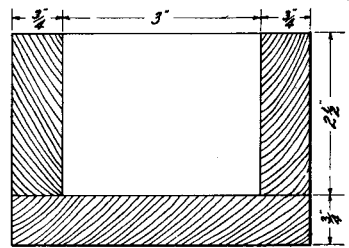

END ELEVATION

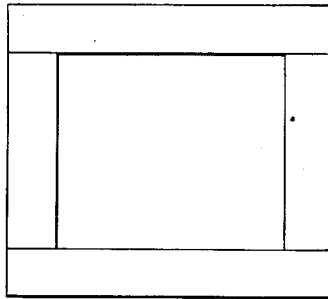

PLAN.

2. Box

Suitable for practice in planing and nailing
Material: Pine

Pieces	Thickness	Width	Length
1	Inches 1	Inches $2\frac{3}{4}$	Inches 18
1	1	$4\frac{3}{4}$	$5\frac{1}{4}$

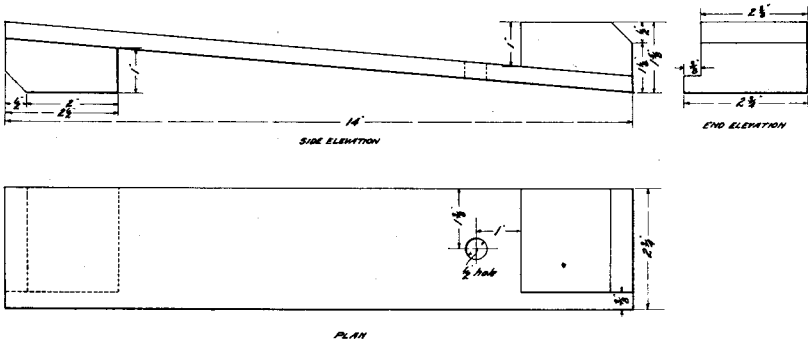
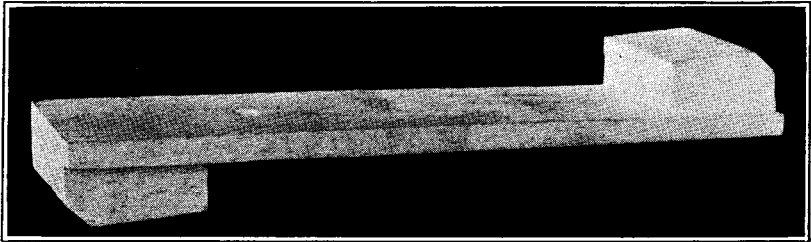

3. BENCH HOOK

Gives practice in squaring and in paring with chisel

Material: Pine

Pieces	Thickness	Width	Length
1	Inches $1\frac{3}{4}$	Inches 3	Inches $14\frac{1}{2}$

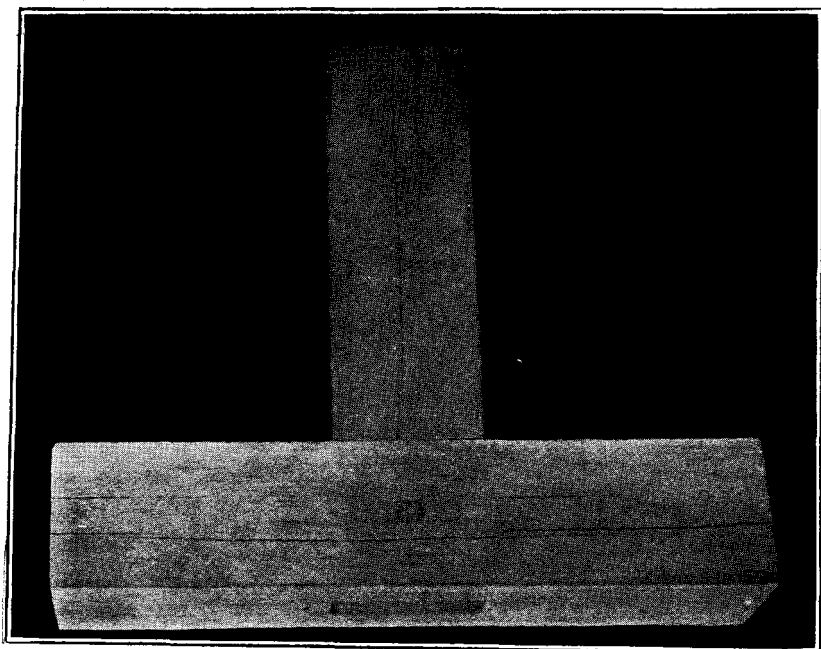

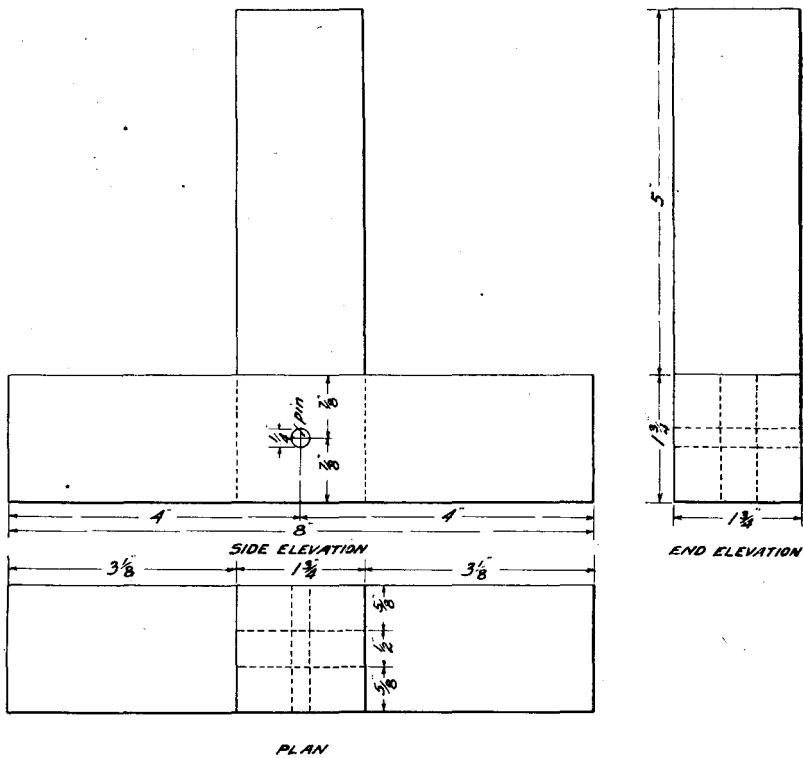

4. MORTISE AND TENON JOINT

Requires careful work in mortising and sawing

Material: Pine

Pieces	Thickness	Width	Length
1	Inches 2	Inches 2	Inches 15 1/2

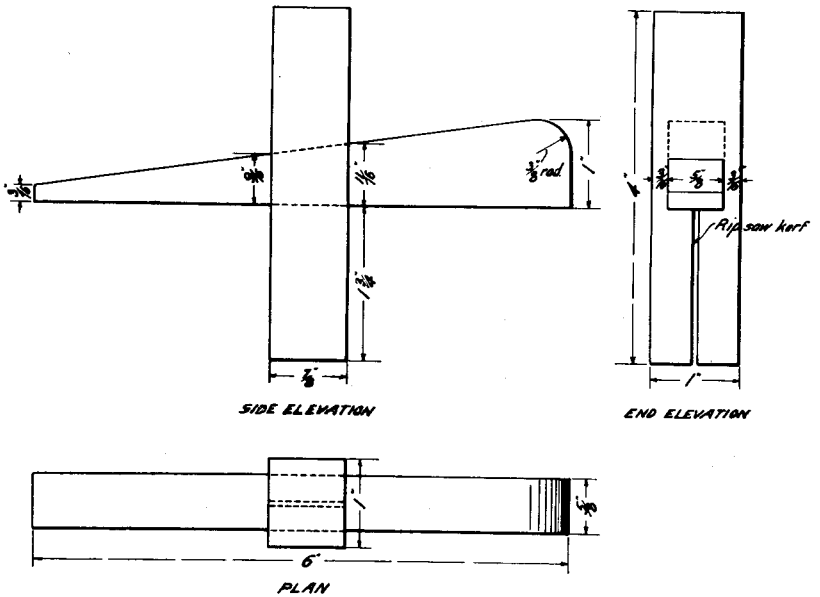
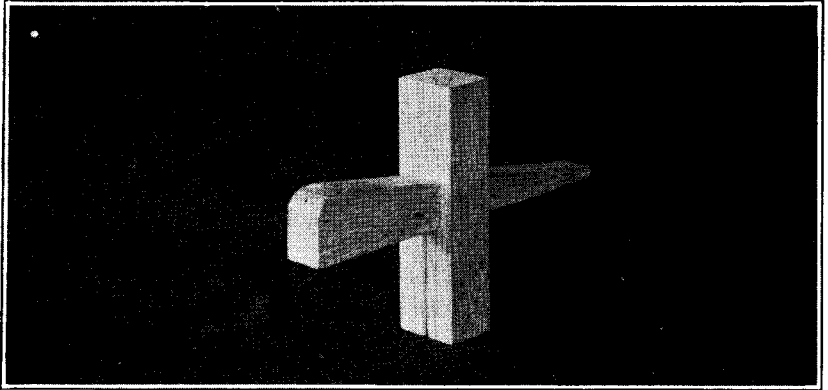

5. SAW JOINTER

Gives practice in working small pieces

Material: Pine

Pieces	Thickness	Width	Length
1	Inches 1	Inches $1\frac{1}{8}$	Inches $10\frac{1}{2}$

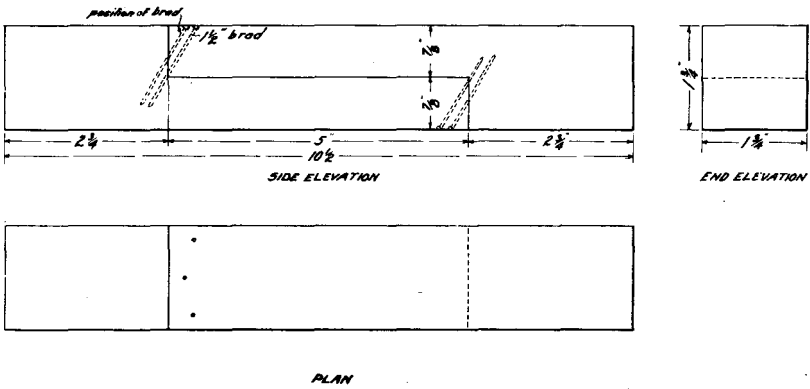

6. HALVED SPLICE

Gives practice in accuracy and nailing

Material: Pine

Pieces	Thickness	Width	Length
1	Inches 2	Inches 2	Inches 16

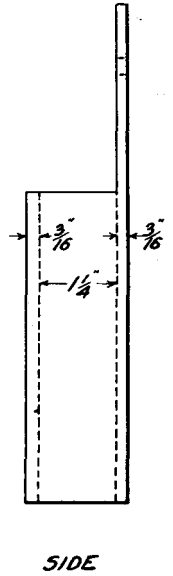
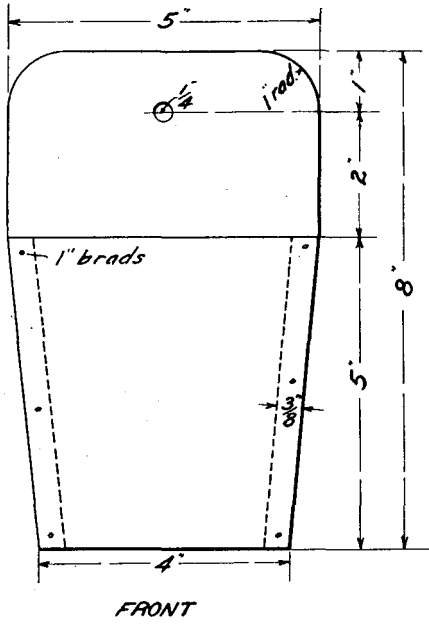

7. WHISK-BROOM HOLDER

To be finished with stain and wax

Material: Pine

Pieces	Thickness	Width	Length
1	Inches $\frac{3}{16}$	Inches 5	Inches 8
1	$\frac{3}{16}$	5	5
2	$\frac{3}{8}$	$1\frac{1}{4}$	$5\frac{1}{4}$

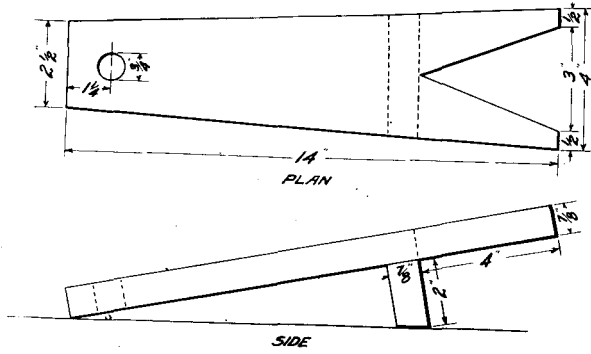

8. BOOTJACK

To be finished with stain and wax

Material: Pine

Pieces	Thickness	Width	Length
1	Inches 7/8	Inches 4	Inches 14
1	7/8	2	4

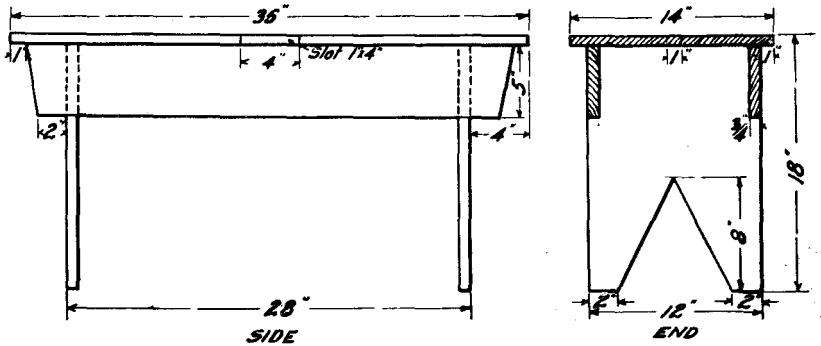

9. BENCH

To be finished with two coats of paint
Material: Pine

Pieces	Thickness	Width	Length
	Inches	Inches	Inches
2	3/4	12	17 1/4
2	3/4	5	34
1	3/4	14	36

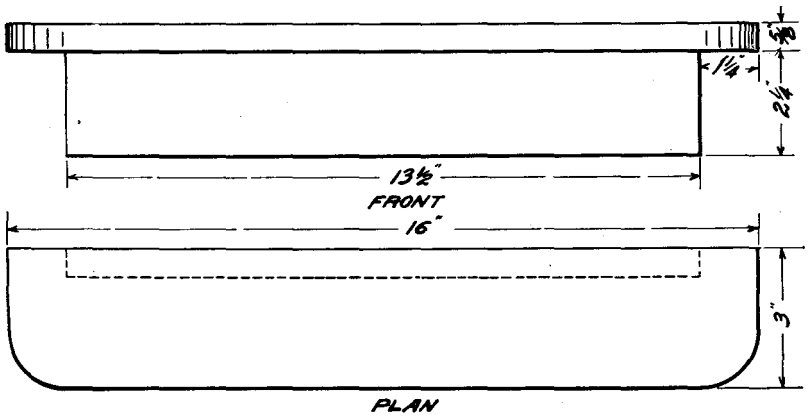

10. SHELF

To be finished with stain and wax
Material: Oak

Pieces	Thickness	Width	Length
	Inches	Inches	Inches
1	5/8	3	16
1	5/8	2 1/4	13 1/2

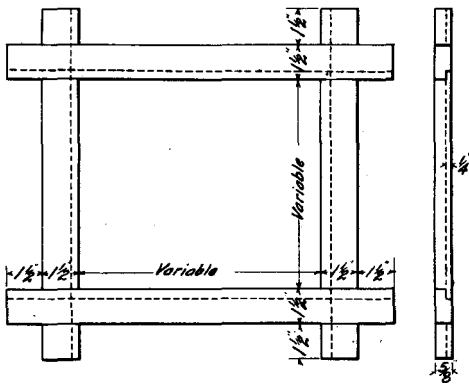

11. PICTURE FRAME

To be finished with stain and wax

Material: Oak

Pieces	Thickness	Width	Length
2	Inches $\frac{5}{8}$	Inches $1\frac{1}{2}$	variable
2	$\frac{5}{8}$	$1\frac{1}{2}$	variable

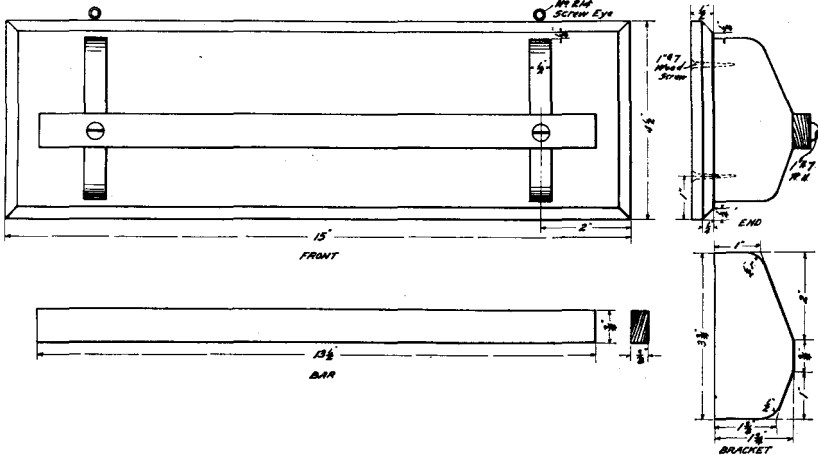

12. NECKTIE RACK

To be finished with stain and wax or wood filler and varnish

Material: Oak

Pieces	Thickness	Width	Length
1	Inches $\frac{1}{2}$	Inches $4\frac{1}{2}$	Inches 15
1	$\frac{3}{8}$	$\frac{3}{4}$	$13\frac{1}{2}$
2	$\frac{1}{2}$	$1\frac{3}{4}$	$3\frac{3}{4}$

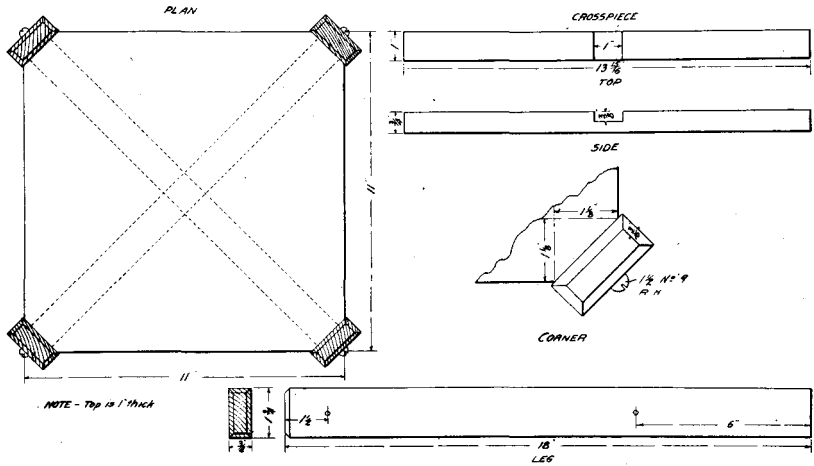

13. PLANT STAND

To be finished with stain and wax

Material: Oak

Pieces	Thickness	Width	Length
1	Inches 1	Inches 11	Inches 11
4	3/4	1 3/4	18
2	3/4	1	13 1/8

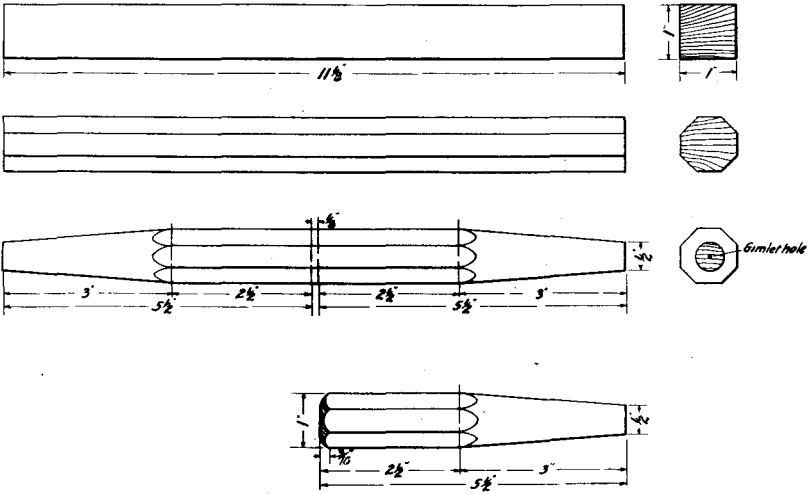

14. FILE HANDLES

To be finished by rubbing with raw linseed oil

Material: Oak

Pieces	Thickness	Width	Length
1	Inches 1	Inches 1	Inches $11\frac{1}{8}$

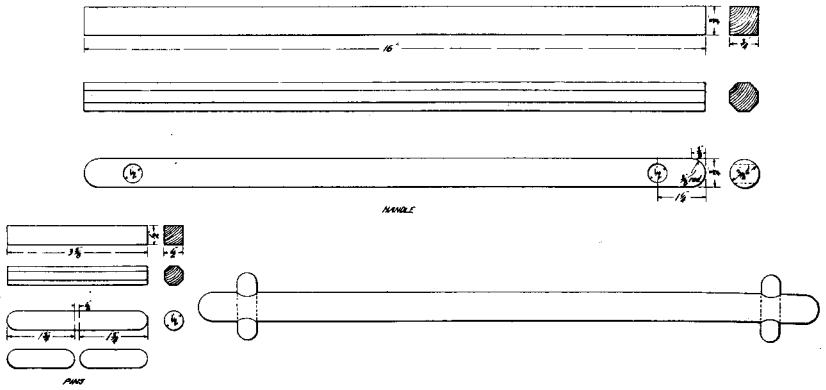

15. VISE HANDLE

To be finished by rubbing with raw linseed oil

Material: Hickory

Pieces	Thickness	Width	Length
	Inches	Inches	Inches
1	$\frac{3}{4}$	$\frac{3}{4}$	16
1	$\frac{1}{2}$	$\frac{1}{2}$	$3\frac{5}{8}$

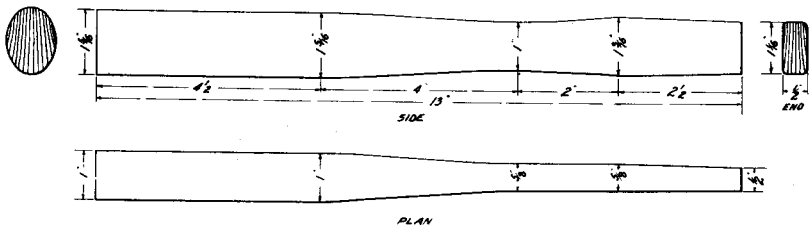

16. CARPENTERS' HAMMER HANDLE

To be finished by rubbing with raw linseed oil

Material: Hickory

Pieces	Thickness	Width	Length
	Inches	Inches	Inches
1	1	$1\frac{1}{8}$	13

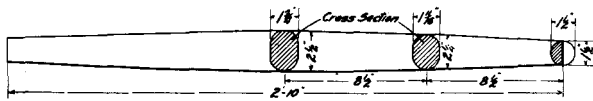
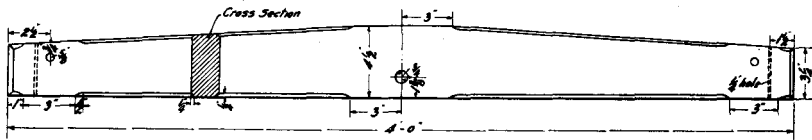

17. EVENER AND SINGLETREE

To be finished with two coats of paint

Material: Hickory or Oak

Pieces	Thickness	Width	Length
1	Inches 2	Inches 4 1/2	Inches 48
2	1 3/4	2 1/2	34

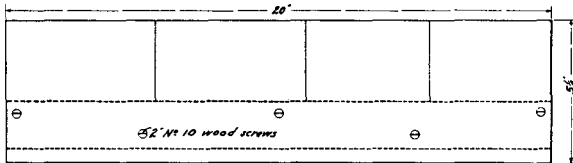
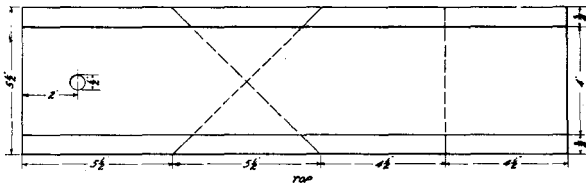

FRONT

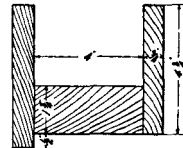

END

18. MITER BOX

To be finished with shellac

Material: Pine

Pieces	Thickness	Width	Length
1	Inches 1 3/4	Inches 4	Inches 20
1	3/4	5 1/4	20
1	3/4	4 3/4	20

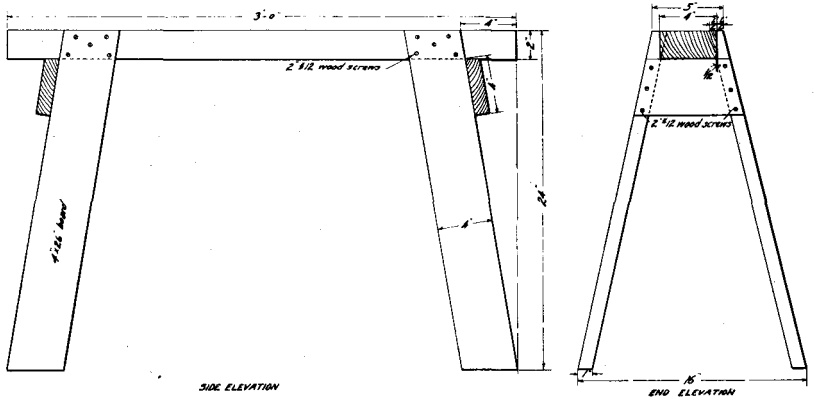

19. SAWHORSE

To be left white
Material: Pine

Pieces	Thickness	Width	Length
	Inches	Inches	Inches
1	2	4	36
4	1	4	26
2	1	4	8

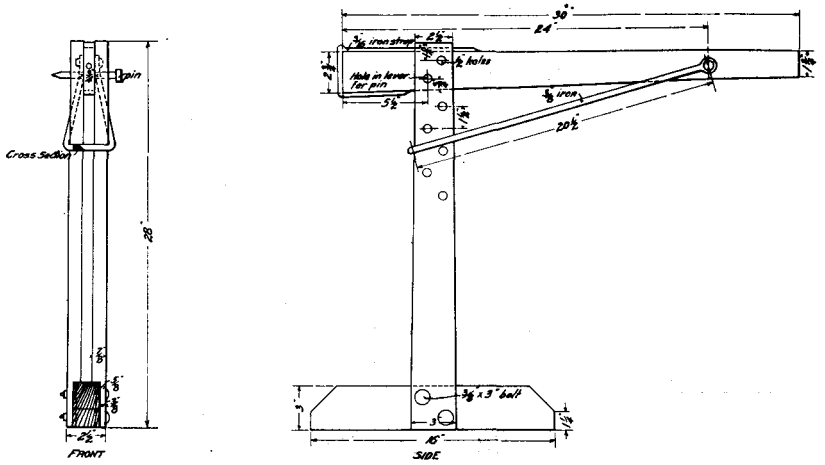

20. WAGON JACK

To be finished with two coats of paint
Material: Oak

Pieces	Thickness	Width	Length
	Inches	Inches	Inches
2	7/8	3	28
1	3/4	2 3/4	30
1	1 3/4	3	16

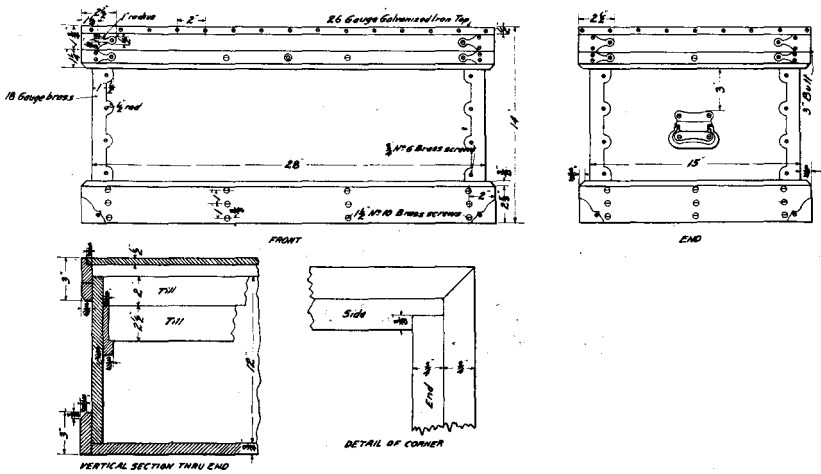

21. TOOL CHEST

To be finished with two coats of paint

Material: Pine

Pieces	Thickness	Width	Length
	Inches	Inches	Inches
2	3/4	12	14 1/4
2	3/4	12	28
2	3/4	3	16 3/4
2	3/4	3	29 3/4
2	3/4	1 3/4	16 3/4
2	3/4	1 3/4	29 3/4
2	3/4	1 1/4	16 3/4
2	3/4	1 1/4	29 3/4
3 D & M	3/4	6	28
3	1/2	10	15 3/4
1	1/2	7	26 3/8
1	1/2	7	25 3/8
2	1/2	1 1/2	26 3/8
2	1/2	2	25 3/8
2	3/4	3 1/2	13 1/2
3	3/4	1 1/2	6
3	3/4	2	6

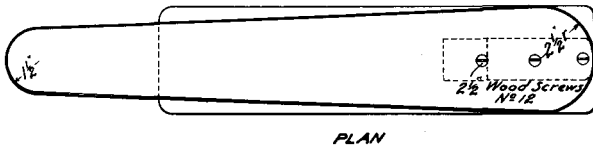

PLAN

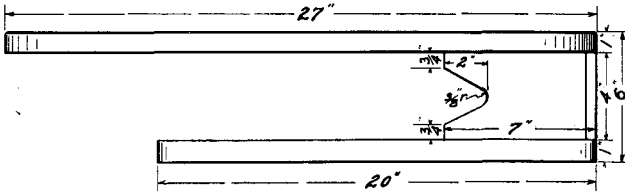

SIDE ELEVATION

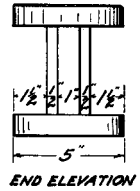

END ELEVATION

22. SLEEVE BOARD

To be finished with shellac
Material: Pine

Pieces	Thickness	Width	Length
	Inches	Inches	Inches
1	2	4	7
1	1	5	27
1	1	5	20



SIDE ELEVATION



END ELEVATION

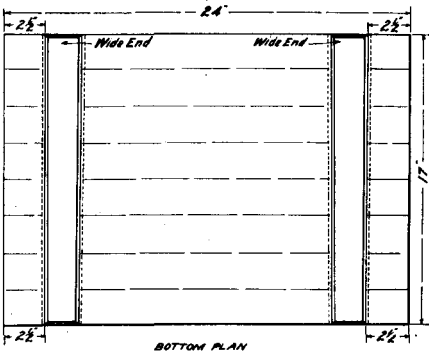

BOTTOM PLAN

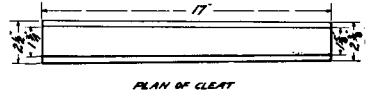

PLAN OF CLEFT

23. DRAWING BOARD

To be left white
Material: White pine

Pieces	Thickness	Width	Length
	Inches	Inches	Inches
8	1	2 1/4	25
2	3/4	2 5/8	18

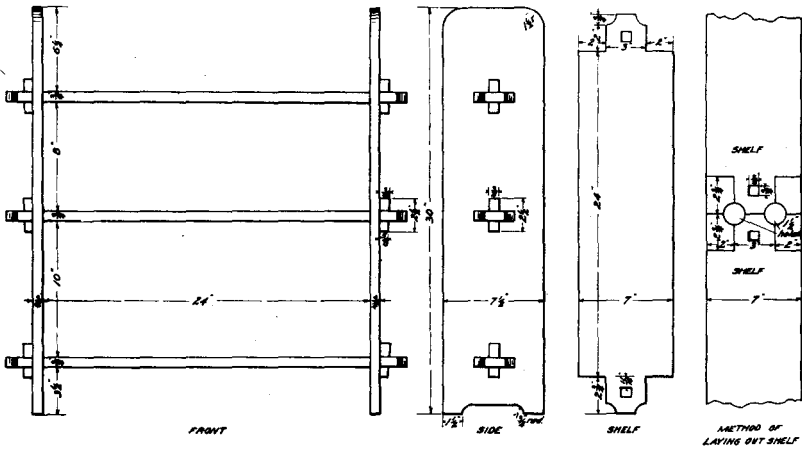

24. KNOCKDOWN BOOKRACK

To be finished with stain and wax

Material: Oak

Pieces	Thickness	Width	Length
	Inches	Inches	Inches
2	3/4	7 1/2	30
3	3/4	7	29 1/2
6	3/4	3/4	2 1/2

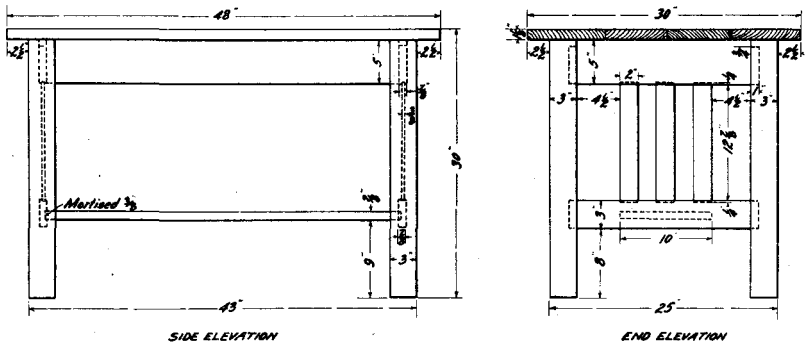

25. LIBRARY TABLE

To be finished with stain and wax, or filler and varnish

Material: Oak

Pieces	Thickness	Width	Length
	Inches	Inches	Inches
4	3	3	28 7/8
2	7/8	5	21
2	7/8	5	39
2	7/8	3	21
6	3/8	2	13 3/8
1	7/8	10	39 7/8
1	1 7/8	30	48

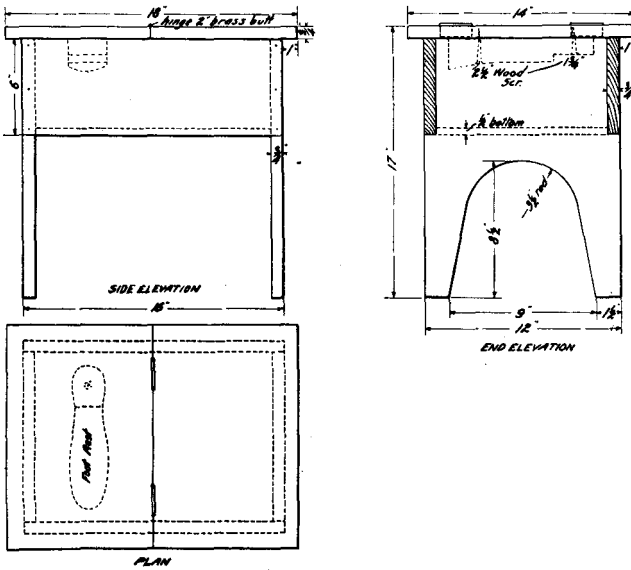
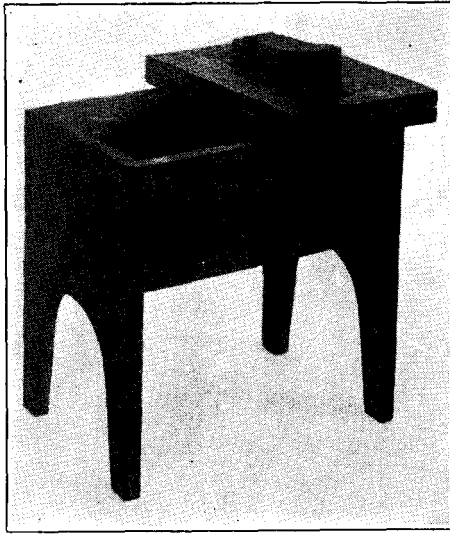

26. BLACKING STAND

To be finished with stain and wax

Material: Pine with oak top

Pieces	Thickness	Width	Length
	Inches	Inches	Inches
2	$\frac{3}{4}$	12	$16\frac{1}{4}$
2	$\frac{3}{4}$	6	16
1.	$\frac{1}{2}$	$10\frac{1}{2}$	$14\frac{1}{2}$
2 Oak	$\frac{3}{4}$	9	14

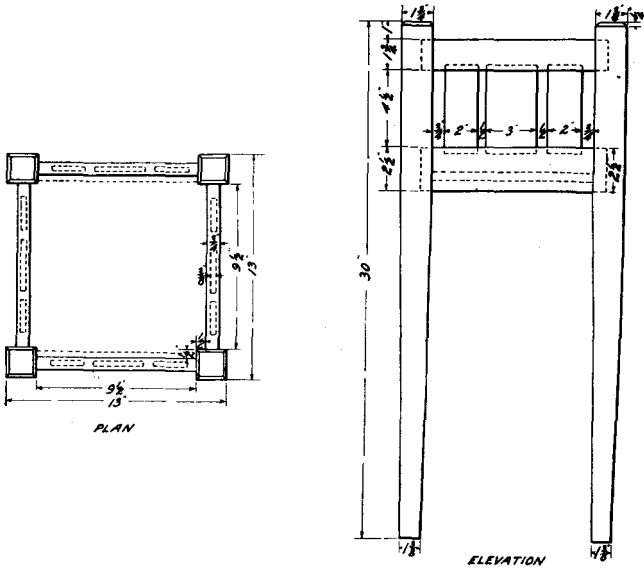
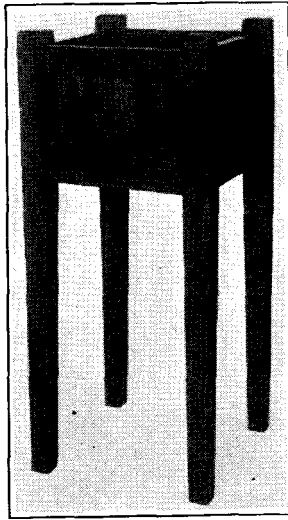

27. WORKBASKET

To be finished with stain and wax

Material: Ash

Pieces	Thickness Inches	Width Inches	Length Inches
4	1 3/4	1 3/4	30
4	3/4	1 3/4	11 1/2
4	3/4	2 1/2	11 1/2
8	3/8	2	5
4	3/8	3	5
2	3/8	3/4	9 1/2
1	3/4	10 1/2	10 1/2

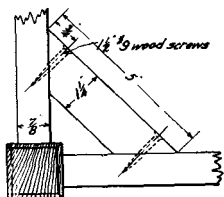
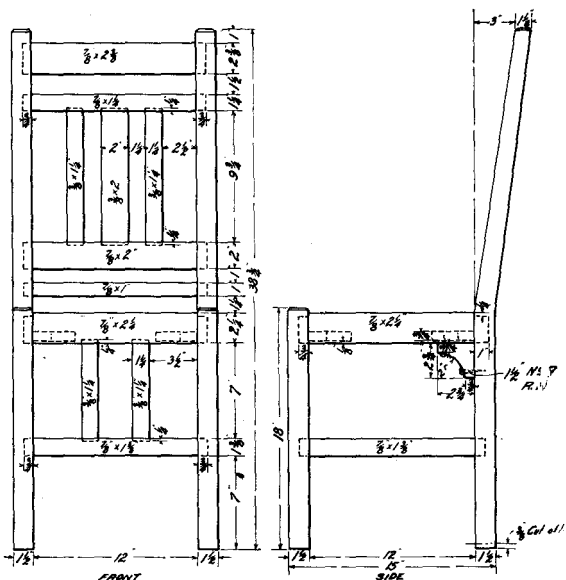
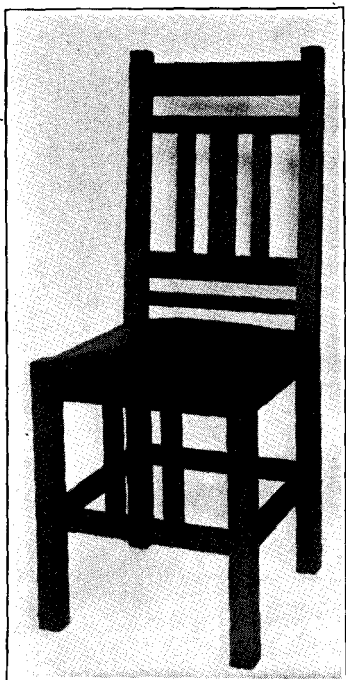

DETAIL OF CORNER BRACING

28. CHAIR

To be finished with stain and wax, or filler and varnish

Material: Oak

Pieces	Thickness Inches	Width Inches	Length Inches
1	1 1/2	5	39
2	1 1/2	1 1/2	18
2	7/8	2 1/4	13 3/4
2	7/8	2 1/4	13 1/2
4	7/8	1 3/8	13 1/2
1	7/8	1	13 1/2
1	7/8	2	13 1/2
1	7/8	1 1/4	13 1/2
1	7/8	2 3/8	13 1/2
4	3/4	1 1/4	5
2	7/8	2 3/4	2 3/4
2	3/8	1 1/4	10 1/4
2	3/8	1 1/4	7 1/2
1	3/8	2	10 1/4
1 Pine	3/4	12 3/4	12 3/4

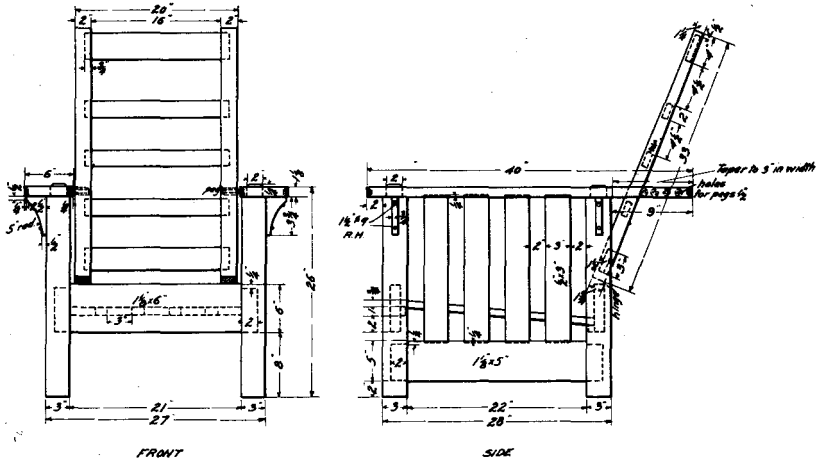

29. MORRIS CHAIR

To be finished with stain and wax

Material: Oak

Pieces	Thickness	Width	Length
	Inches	Inches	Inches
4	3	3	26 $\frac{1}{4}$
2	1 $\frac{1}{8}$	6	40
2	1 $\frac{1}{8}$	5	26
2	1 $\frac{1}{8}$	6	25
2	1 $\frac{3}{4}$	2	33
1	1 $\frac{1}{8}$	3	17 $\frac{1}{2}$
1	$\frac{3}{4}$	4	17 $\frac{1}{2}$
3	$\frac{3}{4}$	2	17 $\frac{1}{2}$
1	$\frac{3}{4}$	2 $\frac{1}{2}$	15
2	$\frac{3}{4}$	1	21
5	$\frac{3}{4}$	3	24
1	1	1	8
8	$\frac{1}{2}$	3	18 $\frac{3}{8}$



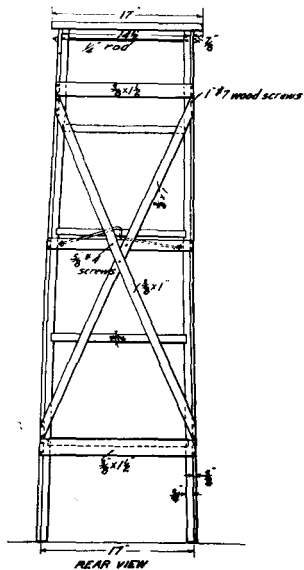
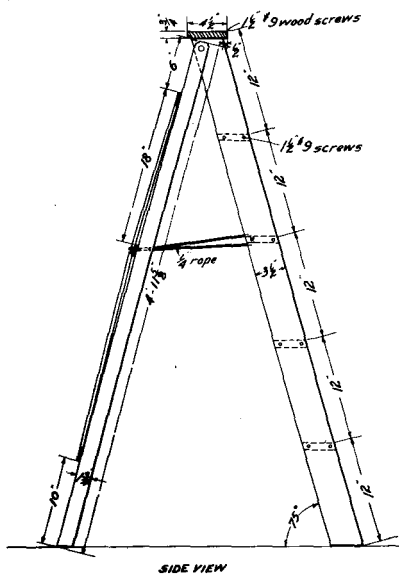
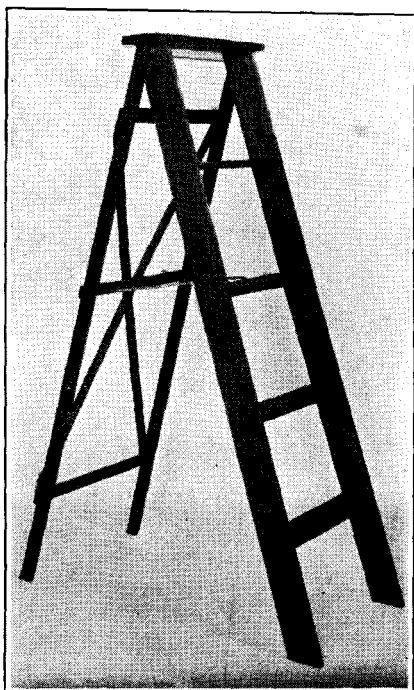

30. STEPLADDER

To be finished with stain and wax

Material: Oak

Pieces	Thickness inches	Width Inches	Length Inches
1	3/4	4	16 1/2
1	3/4	4	16
1	3/4	4	15 1/2
1	3/4	4	15
1	3/4	4 1/2	17
2	3/4	3 1/2	60
2	3/8	1 3/4	59 5/8
2	3/8	1	42
1	3/8	1 1/2	18
1	3/8	1 1/2	16
1	3/8	1 1/4	17

BOOKS ON WOODWORKING AND CARPENTRY

ALLEN, E. G.	Manual Training for Common Schools. Chas. Scribner's Sons, New York.....	\$1.00
BEATTIE, W. R.	The Repair of Farm Equipment, Farmers' Bulletin 347. United States Department of Agriculture, Washington, D. C.	Free
GOSS, W. F.	Bench Work in Wood. Ginn & Company, Chicago.....	.85
GRIFFITH, I. S.	Essentials of Woodworking. The Manual Arts Press, Peoria, Ill.	1.25
HALL, A. N.	Handicraft for Handy Boys. Lothrop, Lee & Shepard Co., Boston.....	2.00
HICKS, I. P.	Builders' Guide. David Williams Company, New York.....	1.00
HODGSON, F. T.	The Steel Square, Vol. I. F. J. Drake & Co., Chicago.....	.50
KIDDER, F. E.	Building Construction and Superintendence Carpenters' Work. William T. Comstock, New York.....	4.00
KING, C. A.	Elements of Construction. American Book Co., Chicago.....	.70

KING, C. A.		
	Elements of Woodwork.	
	American Book Co., Chicago.....	\$.60
KING, C. A.		
	Teachers' Handbook.	
	American Book Co., Chicago.....	1.00
PARK, J. C.		
	Educational Woodworking for Home and School.	
	The Macmillan Co., New York.....	1.00
RICHEY, H. G.		
	The Building Mechanics' Ready Reference.	
	Carpenters' and Woodworkers' Edition.	
	John Wiley & Sons, New York.....	1.50
RITCHEY, S. E.		
	Woodwork.	
	The American Book Co., Chicago.....	1.45
SELDEN, F. H.		
	Elementary Cabinetwork.	
	Rand McNally & Co., Chicago.....	1.00
SELDEN, F. H.		
	Elementary Woodwork.	
	Rand McNally & Co., Chicago.....	1.00
TATE, J. M.		
	Training in Woodwork.	
	Northwestern School Supply Co., Minneapolis.....	.85
WHEELER, C. G.		
	Woodworking for Beginners.	
	G. P. Putnam's Sons, New York.....	2.50
WINDSOR, H. H.		
	Mission Furniture. Three volumes.	
	Popular Mechanics Co., Chicago, per volume.....	.50

INDEX

Additional tools	9
Bench	20
Bench hook.....	13
Blacking stand.....	31
Book list	37-38
Boot jack	19
Box	12
Care of tools.....	9
Carpenters' hammer handle.....	24
Chair	33
Drawing board	28
Evener and singletree.....	25
Farm shop and work-bench.....	5
Farmers' work-bench	7
File handles	23
Halved splice.....	17
Introduction	5
Knockdown bookrack	29
Library table	30
Materials	9
Miter box	25
Morris chair.....	34-35
Mortise and tenon joint.....	14-15
Necktie rack	21
Picture frame	21
Plant stand.....	22
Quality of tools.....	9
Saw jointer	16
Sawhorse	26
Selection of exercises	10
Shelf	20
Sleeve board	28
Squaring-up exercise	11
Stepladder	36
Tool chest	27
Tools for farm shop.....	8
Vise handle	24
Wagon jack	26
Whisk-broom holder.....	18
Work-bench	6
Workbasket	32

