

Extension Bulletin 213 (Rev. Jan. 1935)

# SHEEP

SB

# Equipment

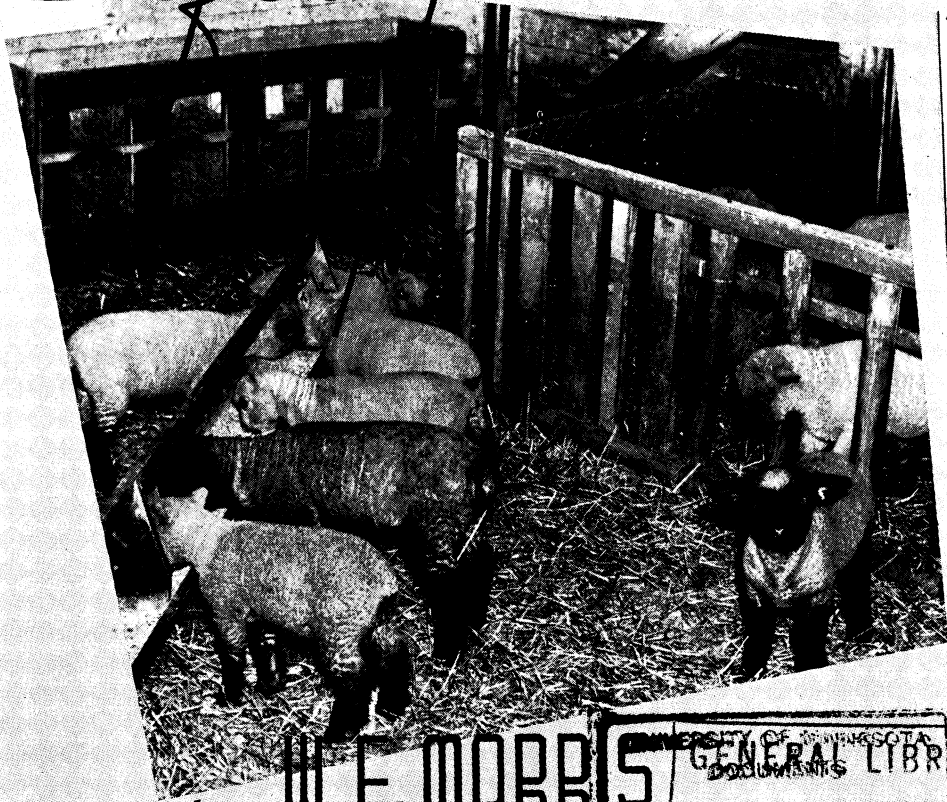

This publication may not be reproduced in whole or in part without the written permission of the U.S. Department of Agriculture. Current information available for University of Georgia Extension Service. See also Extension Bulletin 213.

W. E. MORRIS  
H. G. ZAVORAL

UNIVERSITY OF MINNESOTA  
GENERAL LIBRARY  
DOCUMENTS  
DEC 7 1936 1955  
UNIVERSITY OF GEORGIA

UNIVERSITY OF MINNESOTA  
*Agricultural Extension Service*  
U. S. DEPARTMENT OF AGRICULTURE

# Sheep Equipment

W. E. Morris and H. G. Zavoral

**E**XPENSIVE equipment is unnecessary for sheep raising on Minnesota farms, but protection in winter and in cold, rainy weather is necessary. This need be only housing that provides a dry bed, good ventilation, and freedom from drafts. With the farm flock, such housing should be planned with a view to economy of construction and suitable location for convenience in feeding and other work.

A sheep barn should be located on a dry, well-drained site. Yard space should be adjacent to it. It is best to have the yard and barn located so that they are convenient to the pastures.

In the barn construction, only shelter need be provided. There should be 12 square feet of floor space per ewe. Dirt floors, if well drained, are satisfactory. Wide doors are needed to prevent crowding with its possible injury to pregnant ewes. Doors 8 feet wide are preferable. The barn should be wired for electricity and ample outlets provided, so that heat lamps can be used for lambing in cold weather.

Ample inexpensive feeding equipment should be provided. This will save labor and prevent waste of feed. In feeding troughs for a breeding flock, 15 inches of space per head is needed, while 12 inches is satisfactory for fattening lambs.

Feeding equipment for the breeding flock need not be located in the building although it may be convenient to have the grain troughs there. The grain troughs may be attached to the shed wall or the movable type may be placed on the floor. The roughage should be fed outside except in stormy weather. Feeding outside increases the amount of exercise taken by the ewes, which in turn helps avoid pregnancy disease.

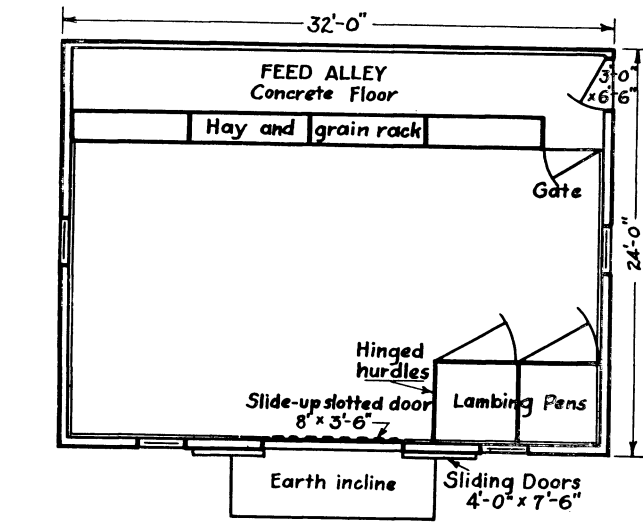

PLAN

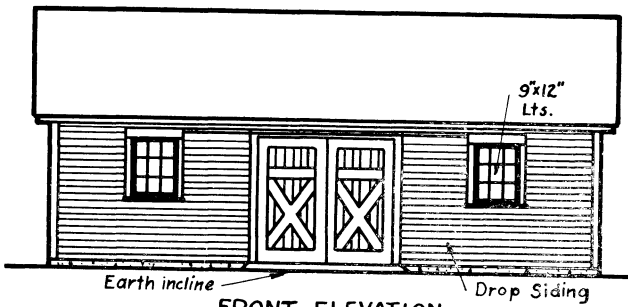

FRONT ELEVATION

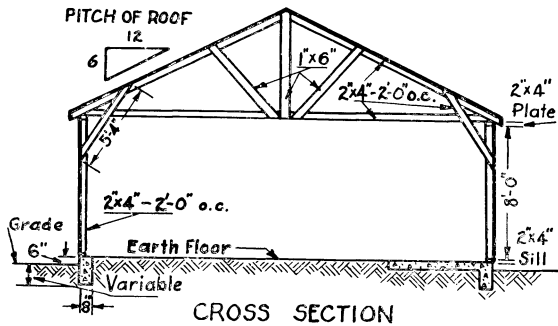

CROSS SECTION

Fig. 1. This one-story type of sheep barn is most satisfactory. It is not expensive, is convenient, and provides suitable shelter. Pole-type construction may also be used.

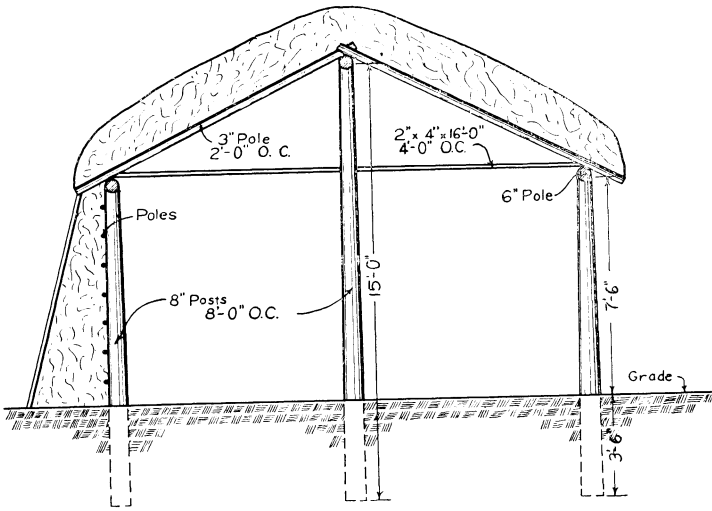

Fig. 2. A straw shed, three sides of straw packed between woven wire or built up with baled straw and a board front, is economical. The top timbers should have woven wire, poles, or boards over them to support the stack roof. A permanent roof of lumber or sheet metal is more expensive, but more permanent. To provide shade in open fields, this type of shed may be set up of lighter construction with all four sides open and a flat roof with a light straw covering.

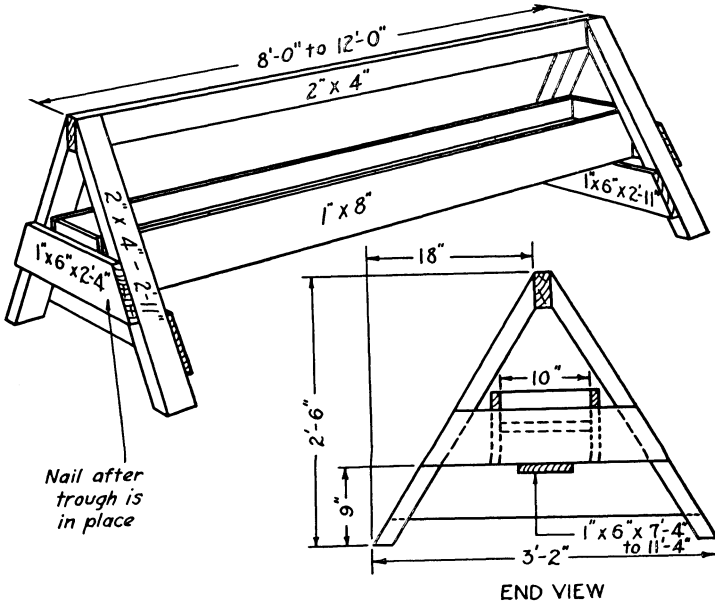

Fig. 3. A movable type of reversible feeding trough. Feeding troughs may be of any length, depending on the individual needs.

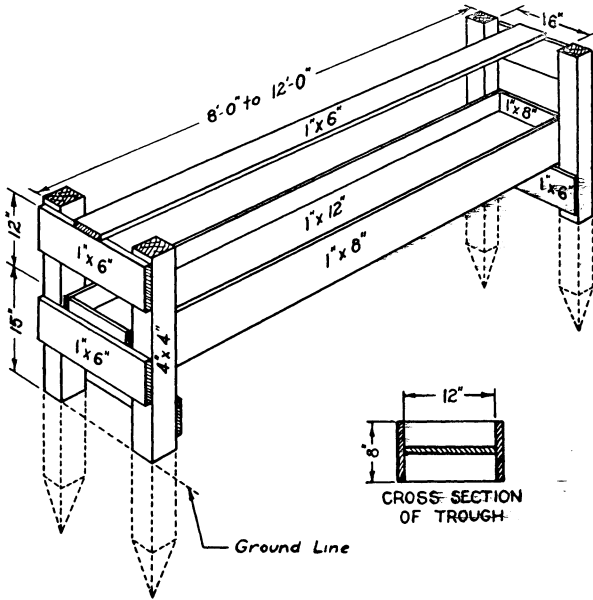

Fig. 4. There are many types of troughs for feeding grain. The double or reversible type is convenient for cleaning and drying out. By flopping it over, the job is done. These are shown in both the movable (Fig. 3) and stationary type (Fig. 4).

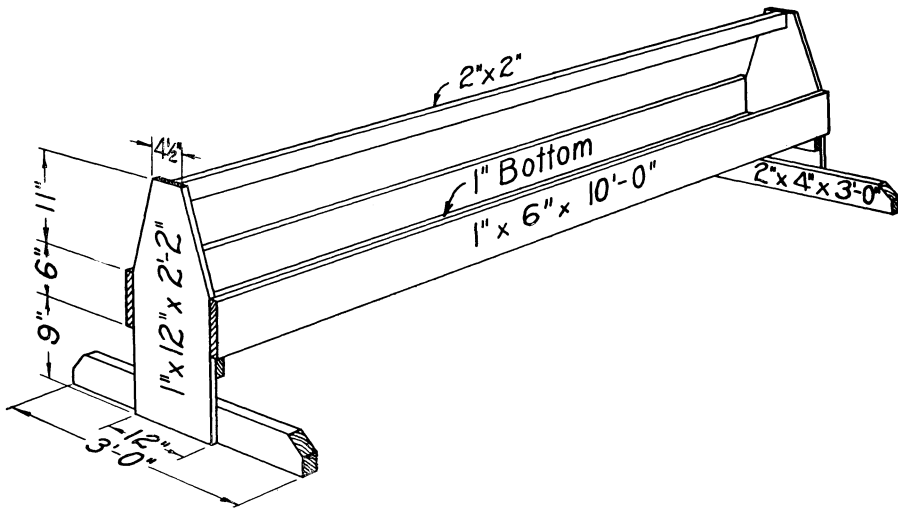

Fig. 5. A single nonreversible trough is shown for cheaper construction. It is not as satisfactory from a cleaning standpoint as the reversible troughs.

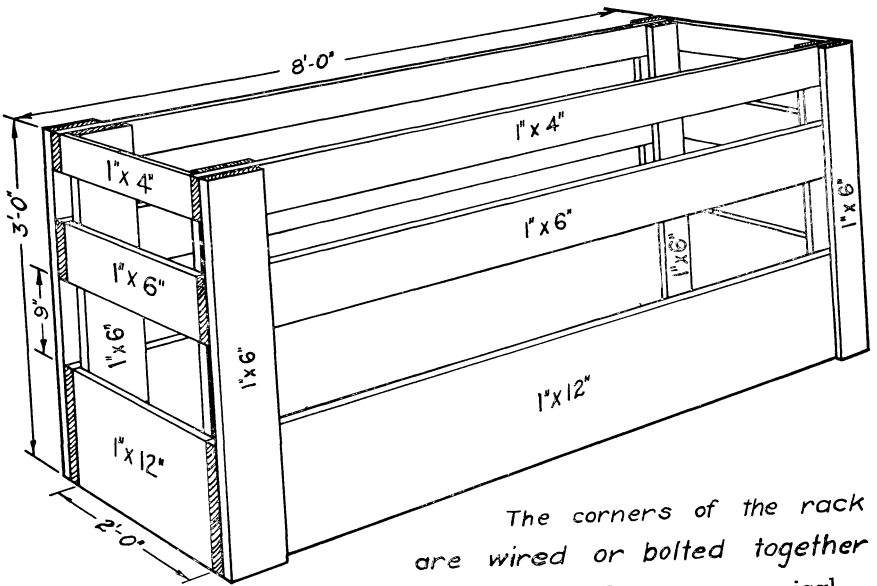

Fig. 6. The knock-down or panel feed rack is an economical piece of equipment for feeding roughage to fattening lambs. These racks can be set up as bunks, as shown in the drawing, or arranged as fences with the hay fed on the far side, the sheep feeding through the fence. They can be used for a breeding flock by placing around a hay stack with the hay being fed against the panels on the inside. Locating the stack away from the shed forces the ewes to exercise.

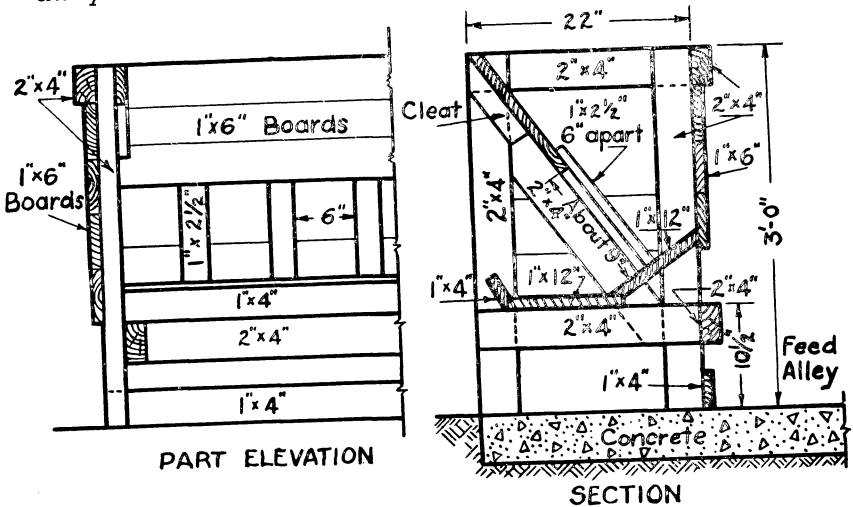

Fig. 7. This rack may be attached to a wall for inside feeding or closed on the back when placed away from a wall. This type will keep the necks fairly free from chaff. Roughage should be fed out of doors except in bad weather.

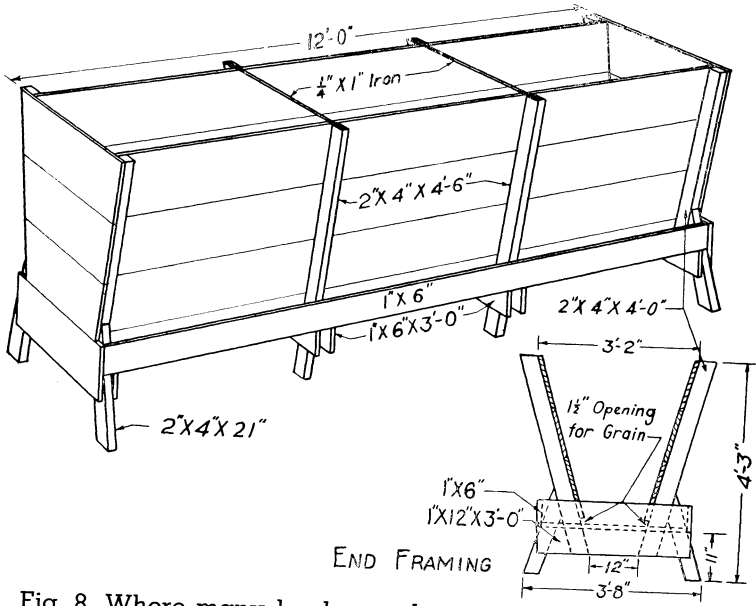

Fig. 8. Where many lambs are being fed, self-feeding may be desirable, using ground hay and grain as the ration. An adjustable feeder permitting feeding down of the feed is necessary. This feeder is cheap and easy to construct. With hand feeding, 12 inches of space is needed for each lamb; with self-feeding, 12 inches for three lambs. Self-feeders need attention several times a day to keep the feed poked down so that it is always available.

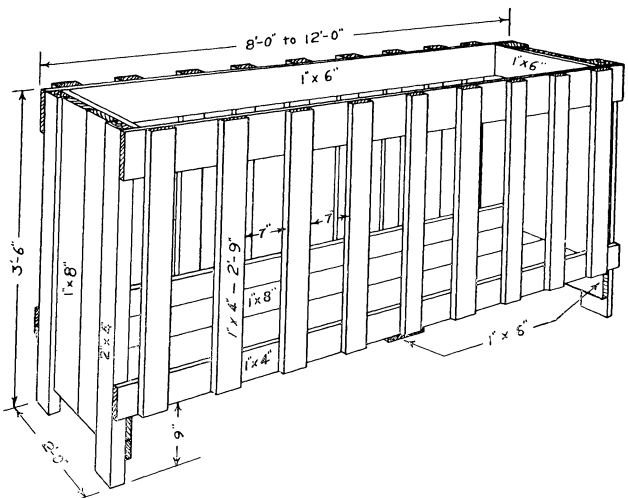
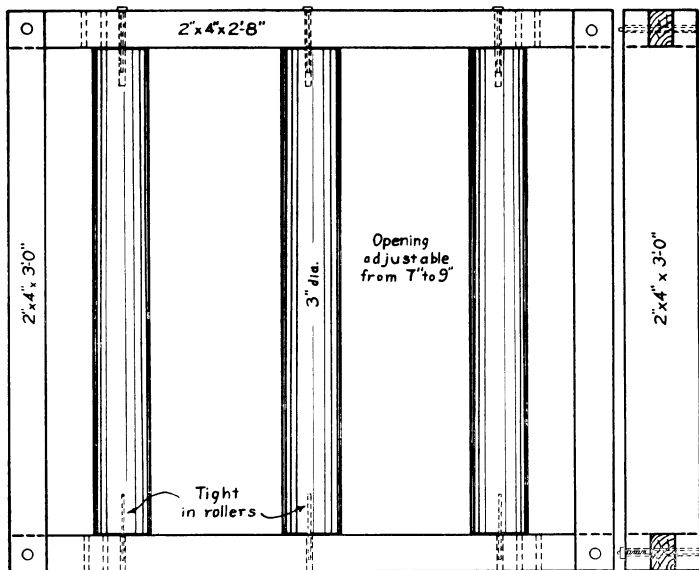
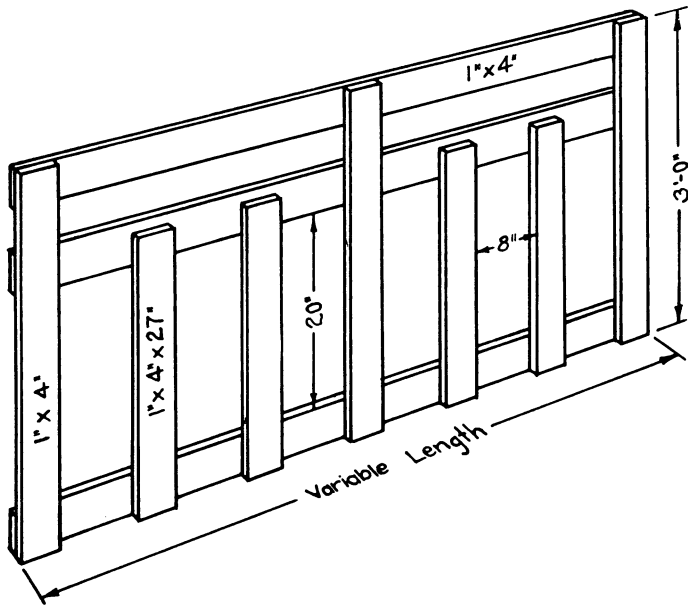

Fig. 9. Combination hay and grain racks are convenient equipment for small flocks. This straight-sided rack will keep fleeces fairly free from chaff, except for the head and neck wool. Chaffy necks can easily be separated at shearing time.



Figs. 10 and 11. A lamb creep is necessary to feed grain and hay to early lambs separately from the ewes. Two types are shown—figure 10 (above) is a light panel; figure 11 (below) is made with rollers. Two to 3-inch cedar posts make satisfactory rollers. This type can be made adjustable by holes in the top and bottom boards through which the pins are inserted into the rollers, thus placing the pins farther apart.



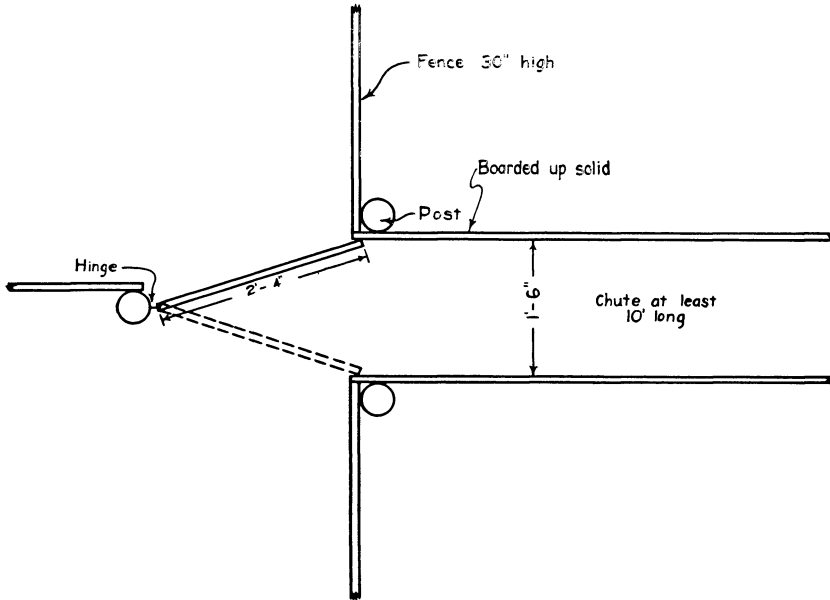

Fig. 12. A sorting chute with a dodge gate is essential to handle a large flock rapidly. These are easily and cheaply constructed. Such a chute is very handy for sorting out top lambs for market or cutting out sheep from the flock.

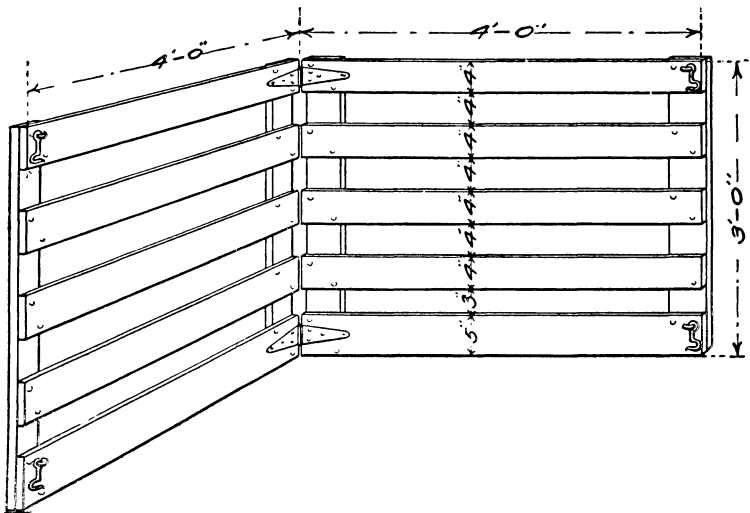

Fig. 13. A 4-foot hinged panel is excellent for a temporary lambing pen. When two are placed together, one of these will form the front and one side for each pen. When not in use, they fold and store away conveniently.

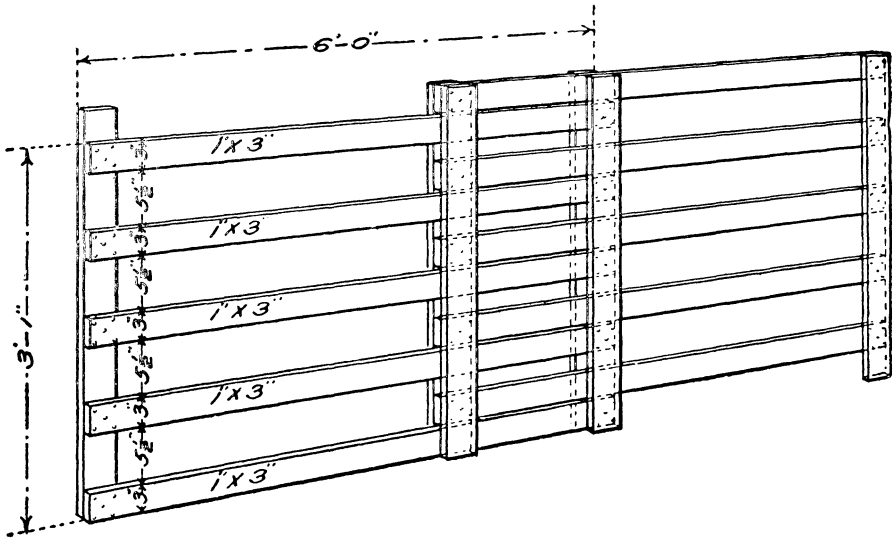

Fig. 14. This type of extension hurdle is valuable around a sheep barn for shutting off a lane or closing a door without excluding the air and light. It is also convenient for moving sheep about the yard.

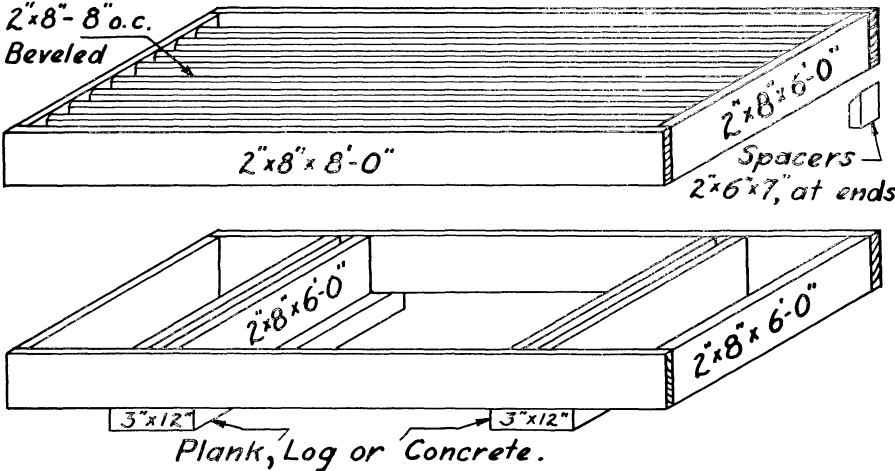

Fig. 15. This cattle or sheep guard set in a road leading to pastures allows a vehicle to pass over without opening gates but will keep the sheep in. Top section rests on bottom section.

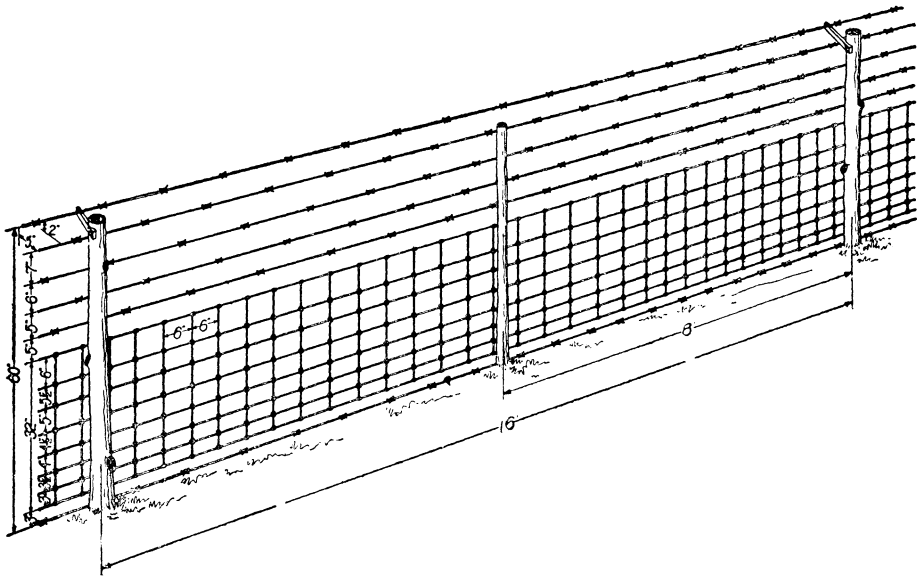

Fig. 16. A dog-proof fence as shown is expensive for pasture fencing. It should be used for a corral where the sheep can be protected at night from dogs. For a corral, 48-inch woven wire with 2 barbs on top is slightly more expensive, but safer.

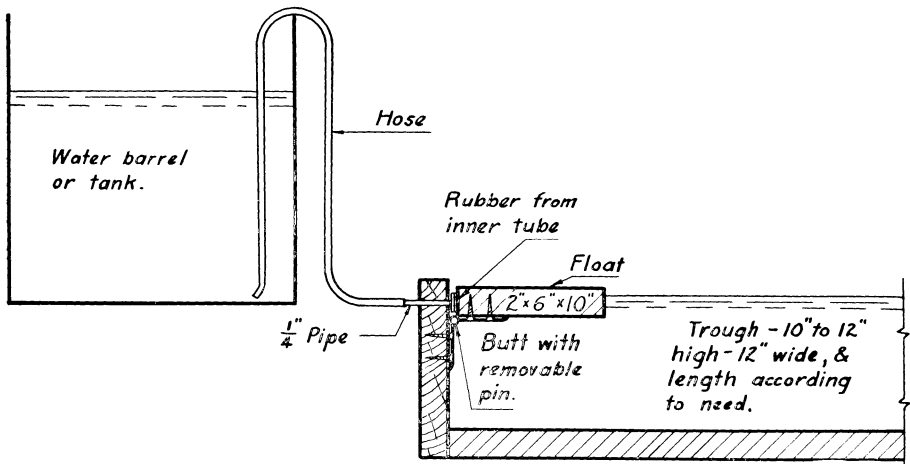

Fig. 17. Frequently it is necessary to pasture sheep where water is not available. This requires the hauling of water. A wagon tank or barrel, according to capacity needed, may be used for this. The water trough illustrated with a float to control the flow makes an inexpensive self-watering piece of equipment when connected to the wagon tank or barrels.

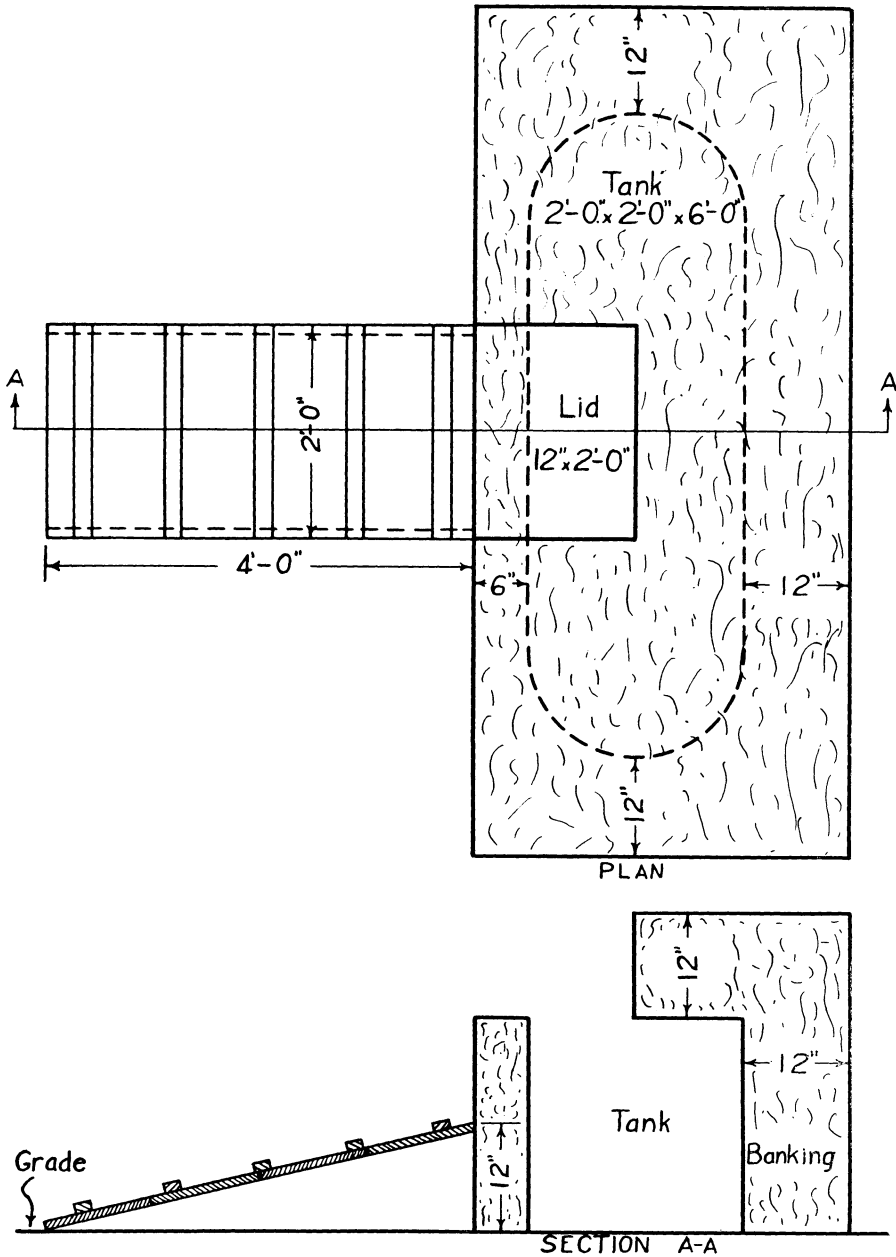

Fig. 18. Sheep need water in winter. A pregnant ewe will drink at least one gallon of water a day where water is well above freezing temperature. A well-insulated tank will keep water at such a temperature, and the flock will benefit from the increased consumption.

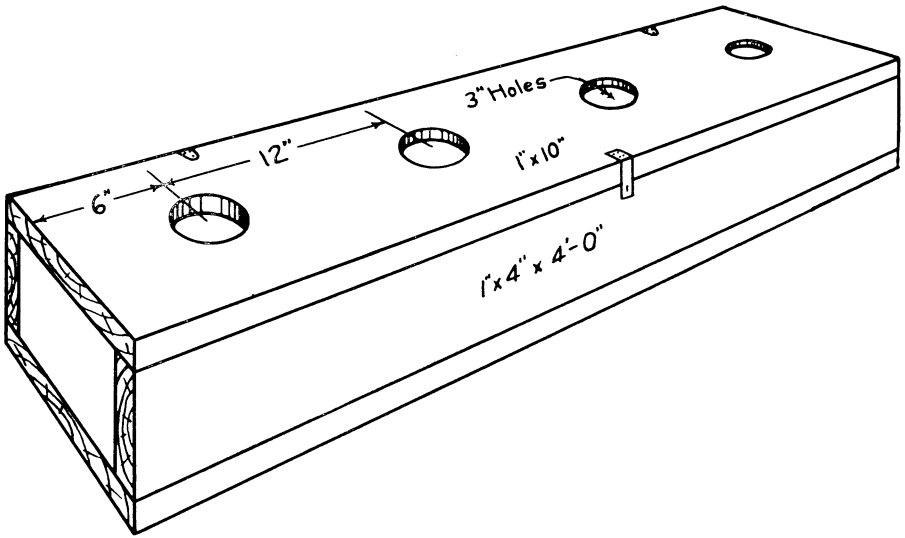

Fig. 19. Prevention is the only control for grub in the head. Pine tar on the noses repels the fly causing the infestation. A salt box with pine tar smeared around the hole that sheep reach through for salt applies the tar where needed. Pads of gunny bagging around these holes hold the pine tar. This salt box is 3 or 4 inches deep and has openings 3 inches across.

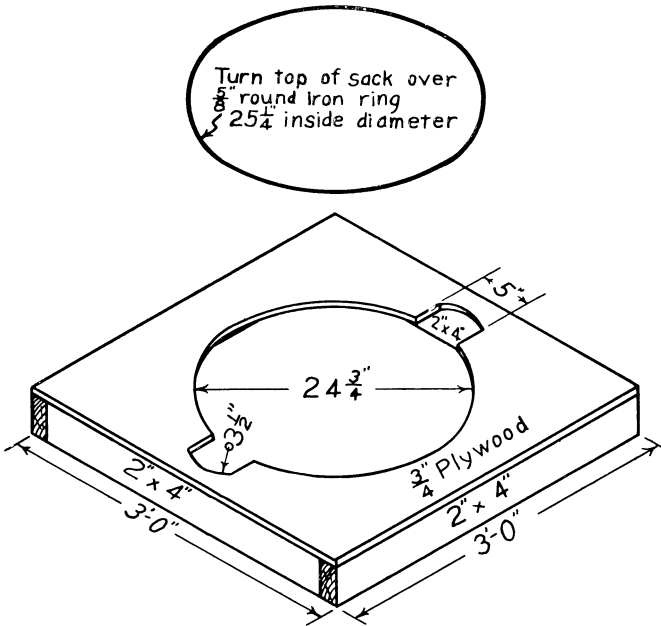

Fig. 20. A wool sack holder is necessary if many fleeces are handled. Sacking is made easier, more fleeces are packed per sack, and the wool is kept in better condition.

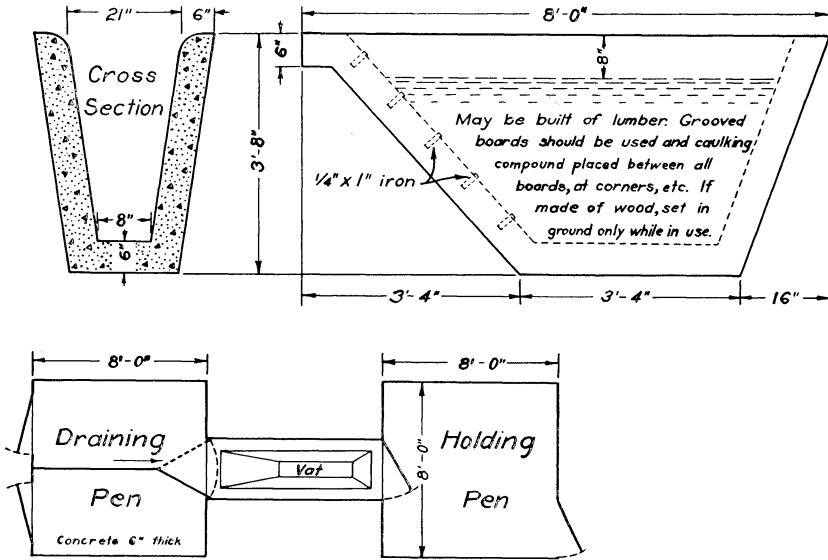

Fig. 21. The above dipping tank may be made of concrete or from lumber in areas where lumber is cheap. This tank may appear narrow, but large sheep can go through easily, and much less dip is needed with these dimensions to accomplish the same results. Drain pens at the outlet of the tank are important to save dip as it drains from the sheep. A holding pen is needed to hold sheep before entering the tank, though a good place to set the tank is at a door through which the sheep are accustomed to going. Portable dipping outfits are available in many areas, offering a convenient dipping service.

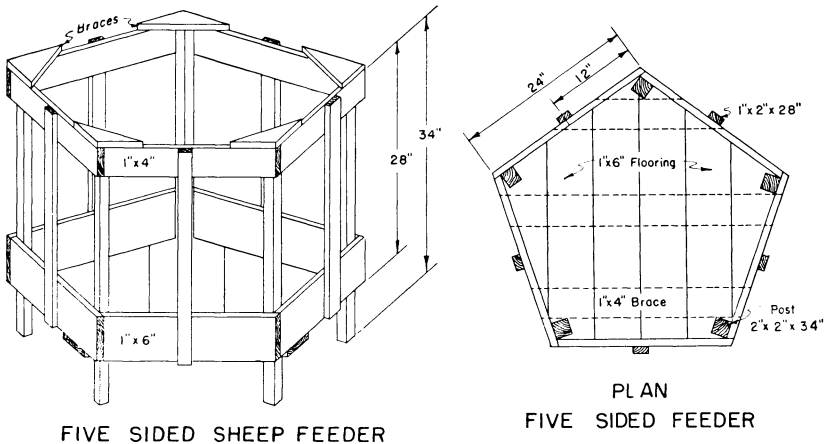

Fig. 22. A convenient combination feeder where space is limited.

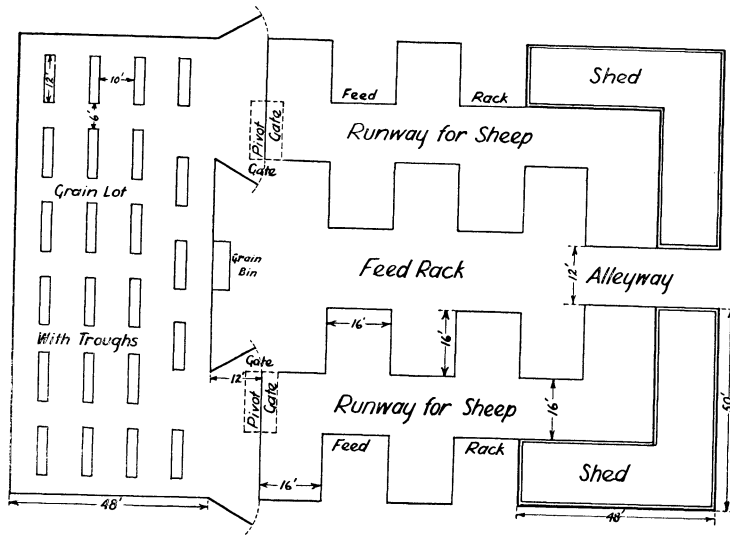

Fig. 23. This plan for a feed lot is designed for 400 fattening lambs. Hay panels as described in figure 6 are arranged irregularly for hay feeding. A wagon can be driven around and hay distributed, with the sheep feeding through the fence. A second lot is provided for the grain troughs. Such an arrangement allows the grain to be put into troughs while the lambs are shut in where feeding on hay. With hand feeding, this arrangement simplifies feeding materially. After the grain is in the troughs, the pivot gates are opened to permit the lambs to enter.

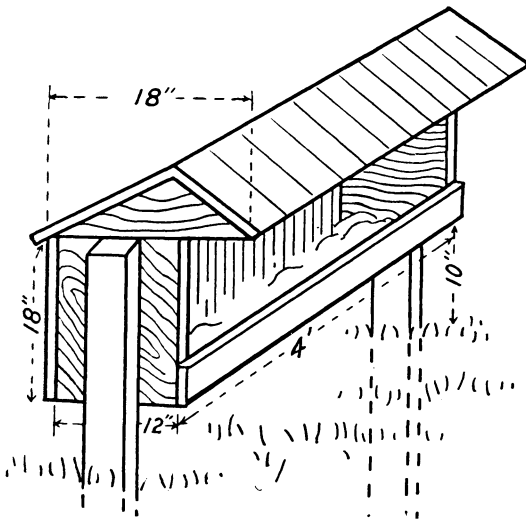

Fig. 24.  
A covered salt box for phenothiazine-salt mixture keeps out rain.

## MISCELLANEOUS EQUIPMENT

For proper and convenient management of a flock, certain tools or special equipment should be provided. Such a tool kit would provide:

1. A good knife for docking, castrating, trimming feet.
2. A pruning shears to be used for docking and trimming feet.
3. A 4-ounce metal syringe for drenching and washing wounds, treatment for maggots, etc.
4. A one-pint, long-necked, small-mouth bottle for drenching if a syringe is not available.
5. For drenching, if preferred: 3 feet of  $\frac{3}{8}$ -inch soft rubber tubing with a 4-inch graniteware funnel on one end and a 6-inch piece of  $\frac{3}{8}$ -inch copper tubing on the other.
6. A 2-ounce jar (an empty cold cream or vaseline jar) to which a wire handle has been attached. This makes a satisfactory measure for measuring drenching doses.
7. A hand sheep shears for trimming long wool locks from around the udder before lambing and for tagging before breeding.
8. An iron chisel about 3 inches wide with a 15-inch handle for docking with a hot iron. This can be made from  $1\frac{1}{4}$ -inch gas pipe.
9. One pint of pine tar for repelling flies after castration and docking and for treatment of other wounds. It is also used for smearing noses during fly time to prevent grub in the head.
10. A wide-mouth bottle (2 to 4 ounces) for dipping navel cord stub with iodine immediately after birth to prevent navel disease.
11. A few ounces of tincture of iodine for disinfection of navel cord.
12. An ear punch or notcher for marking for identification.
13. One ounce of boric acid crystals for treating sore eyes.
14. A pint of turpentine (or of Smear 62 or E. Q. 335)—good for removing maggots.
15. Paper wool twine for tying fleeces.
16. In an emergency a trocar might be handy to relieve bloat.
17. A board  $\frac{3}{4}'' \times 6'' \times 18''$  with holes of  $1\frac{1}{2}''$ ,  $2''$ ,  $2\frac{1}{2}''$  spaced apart. For use with a hot iron in docking, to prevent burning.
18. An earthen or graniteware vessel for mixing bluestone drench.
19. One gallon cresol or similar solution for disinfecting uses.
20. Castor oil—to relieve constipation in lambs.

Figures 13, 14, and 16 were reproduced from USDA Farmers' Bulletin 810 "Equipment for Farm Sheep Raising." Figure 22 was reproduced through the courtesy of Oklahoma A and M College.

UNIVERSITY OF MINNESOTA, INSTITUTE OF AGRICULTURE, ST. PAUL 1, MINNESOTA

Cooperative Extension Work in Agriculture and Home Economics, University of Minnesota, Agricultural Extension Service and United States Department of Agriculture Cooperating, Skuli Rufford, Director. Published in furtherance of Agricultural Extension Acts of May 8 and June 30, 1914.

7500-6-55