

60

MN-2000

EB-60

C.2

# The University of Minnesota

AGRICULTURAL EXTENSION DIVISION

## Special Bulletin No. 60

University Farm, St. Paul

May, 1922

Published by the University of Minnesota, College of Agriculture, Extension Division, F. W. Peck, Director, and distributed in furtherance of the purposes of the cooperative agricultural extension work provided for in the Act of Congress of May 8, 1914.

## SIMPLE STEPS IN LAND CLEARING

By M. J. Thompson and A. J. Schwantes,  
Division of Farm Engineering

### INTRODUCTION

The eighteen counties in the northeastern part of the state embrace a vast acreage of 21,250,000 acres. This territory was originally covered more or less heavily with a growth of pine and other coniferous trees interspersed with considerable areas of hardwood. The timber crop has largely been harvested and a transition from forest to farm is under way on lands suited to agriculture. There are now nearly 35,000 farms in this region. This bulletin will deal with the principles and practices of land clearing adaptable to its development.

### JUSTIFICATION OF CLEARING LAND

To the uninitiated, the job of creating a farm in the cut-over country seems a hopeless task. A few inducements that lead men to attempt it are: (1) The man of limited means can capitalize his labor by converting a piece of raw land into productive land. Many who otherwise would be renters or laborers through life thus acquire a modest competence. (2) The timber on many farms for fuel, fencing, and building, and as a source of income during the winter months through the sale of timber products, is a considerable asset. (3) With the intensive type of farming, dairying, and potato growing in operation, a much smaller cleared acreage is needed than might be supposed. From forty to eighty acres constitutes the family-size farm, and properly managed will afford an income equal to that produced on double the acreage in the grain-growing prairie districts. (4) The lumbering and mining settlements, and the growing towns and cities afford an excellent local market in many places, while cooperative marketing organizations ship much of the surplus. (5) The rainfall is copious and dependable, and total crop failures are unknown. (6) Through the Land Classification Survey, recently begun, by which both state and private lands will be adjudged as agricultural or non-agricultural, the future settler will be protected on the score of soil fertility.

## LAND CLEARING ORGANIZATION

Land clearing is a difficult job at best and consequently organization is very important. It requires the united effort of all concerned to do the job in the cheapest and easiest way possible. There are several different kinds of organizations, but in a general way the purposes of practically all of them may be summed up under three headings: The pooling of funds, the pooling of labor, and the pooling of credit.

### Pooling the Funds

The first of these purposes has to do with the purchase of land clearing materials and equipment, and probably the best illustration of this is the purchasing of explosives in carload quantities. The individual settler buying only a small quantity of explosives must necessarily get it from his local dealer and pay retail prices which usually are 5 or 6 cents per pound higher than carload prices. It is impossible for the dealer to sell for any less and make a profit, but a group of settlers can combine their orders until there are enough to make up a carload. Perhaps it will be hard to get enough orders for a carload in one or even in several communities, but banks and other agencies are usually willing to cooperate in assembling orders and extending credit, where this is necessary and feasible, and in that way very little difficulty is experienced in the process of assembling, even though it is necessary to cover a large area. The other essential to the success of this method is that each settler get his share of the material out of the car when it arrives, thus eliminating all storage charges and most of the handling charges. Sometimes dealers are willing to handle orders on this basis at a margin of from  $\frac{1}{2}$  cent to 1 cent per pound. This is a very small charge for the settler to pay for this service and provides for some one to assume the responsibility. It is possible to get the lowest prices from the explosive manufacturers by ordering in carload quantities and the saving on a minimum car will usually amount to at least \$1,000 or \$1,200.

### Pooling Labor

One man working alone at a job like brushing or stumping, works at a decided disadvantage. Community Land Clearing clubs are formed for the purpose of making it possible for several settlers to exchange help and thus work together. The size of crew will vary, depending on conditions. We will assume that six neighbors have organized such a club. They will probably spend two days on each man's farm, thus making one complete circuit in 12 days. The crew will do brushing and pick-up work after the ground has been frozen, and stumping during the stumping season. We will assume that they are stumping and that they are blasting the stumps clear out and piling them. Two men will do the blasting. Three teams will be on the job skidding stumps to the pile and rolling them together and as the pile gets larger one team will pile with the decking chain while the other two will skid the stumps to the pile. The sixth man will remain at the pile helping the team-

ster hitch to the stumps and rolling the smaller ones on the pile. If a stump puller or a mechanical stump piler or both were used a different sized crew might be better, or they might split up into different groups.

### Pooling of Credit

The best example of the pooling of credit is the Bessette law which was passed during the 1921 session of the state legislature. It provides a means whereby the settler may clear his land by the use of county funds which are raised by a bond issue. The money is then paid back to the county in yearly tax assessments for ten or fifteen years. In order to take advantage of this law, two or more settlers who own jointly not less than 400 acres must petition the county board to clear not less than 100 acres. This 100 acres shall be divided so that not more than 20 acres or less than 5 acres are to be cleared on any 40-acre tract. The county board makes the final decision as to whether or not the clearing will be done. Individual contracts may be let for each piece of clearing, and the settler has a right to be his own contractor, thus affording him a means of employment and at the same time developing his farm. It is practically equivalent to a long time loan which is a very important consideration in farm development.

### LAND TYPES

There are, roughly, five main types of lands based upon soil and vegetation (tree crop): White pine, on both clay and sandy soil; Norway pine and Jack pine, both on sandy loams; mixed conifers and hardwoods on both sandy and clay loams; hardwoods, usually on clay loam. All types will be covered in this discussion.

### BEGINNING OPERATIONS

In starting operations, if wisely guided, the settler will build a very cheap but comfortable shelter for his family and his livestock and will conserve his funds and his main effort for his clearing operations. The big job is to get as soon as possible enough land producing to support his family. Some land must be brushed and stumped at once to provide a garden and a cash crop of potatoes. Additional land must be brushed and seeded for hay and pasture. If there is a wild meadow on the place, it usually pays to clean up the logs and windfalls so that a mower may be run over it. Being inexperienced, his first clearing will be his most expensive, so it is desirable that he select that which is the easiest cleared. This also should be well drained upland.

### DEFINITIONS

Since land clearing is to be the settler's main profession for several years, it should be properly defined. It consists of three stages. (1) The removal of brush and timber growth; (2) stump removal; (3) picking of stones, rocks, and boulders, to be removed

at first breaking. The problem is to get the land opened up as rapidly and cheaply as possible, for the cost of his land is not measured by the price he pays but by the sum of this and the cost of clearing. A lower clearing cost means a smaller investment and a larger annual margin of profit from the crop. Economy in clearing is secured by system on the farm and organized co-operative effort in the community. Systematized clearing and practice, the land-clearing calendar, or seasonal program will first be explained.

### LAND CLEARING TYPES AND SYSTEMS

For most of his clearing the settler will have one of two conditions or a combination of both. He may have green timber with a heavy brush undergrowth, and perhaps a considerable sprinkling of pine stumps scattered through it. Or he may have a field of dead pine or hardwood stumps, covered with a small second growth of alder, poplar, birch, and other species but with no standing timber except perhaps a few dry trees.

In the first case the "delayed clearing" plan is the logical procedure. The forest growth is removed during the fall and winter months; grass seed is sown in the early spring between the stumps. This is pastured from three to five years and the stumps are then removed. This plan has four advantages: (1) The stumping cost is reduced fully one-third or more. (2) A pasture crop is afforded harvested by livestock, worth annually on good land at least \$10 per acre in butterfat values. Young stock will gain 150 pounds in five months on it and it will produce an 80- to 100-pound lamb. (3) The clover sod, droppings of livestock, and decaying wood make the soil more productive and extract its wildness. Duluth records indicate an additional yield per acre of 10 to 20 bushels of oats and 50 bushels of potatoes. (4) With a sod formed, the cost of breaking is reduced and a better seedbed is formed.

Following this plan does not mean that the settler is to suspend his stumping for some years. On the contrary, he will brush and close-cut between cropping seasons, and stump and break in summer, following his seasonable program. If all his stumpage is green, the earlier year's work will be more expensive. But the ordinary farm usually has some old stumpage and he will so arrange his work as to uncover this dead stumpage and remove it while the greener portion is ripening. Since brushing proceeds two or three times as rapidly as stumping, in a year or two the seeded acreage will be several years in advance of the stump-removal stage and the program works automatically.

In the second case, where there is a light brush growth covering dead pine stumps, with probably some hardwoods, the same general plan should be followed, altho there will probably be no material saving in the cost of clearing. But the other three arguments hold with equal force and the farmer will find it an advantage to have a sod ahead of him in most of his stumping work. Since many, if not most, farms have both types, a combination such as suggested in the preceding paragraph will be the logical plan to follow.

### Brushing

By brushing is understood the removal of windfalls and that part of the forest growth remaining after the merchantable timber has been removed. In some of the mixed and hardwood districts both operations occur together or brushing just precedes the removal of timber. Sheep and goats are used for killing brush to a limited extent. It may be killed by firing, an uncommon practice and hedged in by legal restrictions. In the absence of large stumps, it is sometimes cut by special sickle adjustments on mowers. A tractor-drawn machine, cutting at an angle, has been devised, and in the brush country, between the timber and the Red River Valley, it is becoming common practice to plow under everything below three or four inches in diameter. If there is any larger growth, it is removed in advance. But for the most part brush is removed with tools. Material under 1 inch in diameter is readily cut with the



Fig. 1. Brush Tools

- A. Brush hook
- B. Brush knife
- C. Double bit ax—wide blade
- D. Brush hoe—made by James H. Mann Co., Lewistown, Pa.
- E. Brush ax—made by O. E. Olesberg, Bawlf, Alta., Canada

brush scythe. A double bitted axe, weighing about  $3\frac{3}{4}$  pounds, and with a wide blade, is the most useful all-round tool for growth of 1 inch and above. The brush hook, operated by a pulling action upward, is used on coarser brush as well, but it is usually slower and more awkward. The brush machete is excellent for brush more than 2 inches in diameter. It has a cutting edge of 22 inches and may be fashioned by a blacksmith from an old auto spring. There are many valuable special tools.

### Burning Brush

By starting a fire and feeding it, brush may be burned any day in the year, not forgetting legal limitations which provide that brush or stumps may not be burned without permit unless there is snow on the ground. It is frequently thrown into long windrows and burned later when dry. The more common practice is to pile it in large heaps, allow it to season for a period, and then fire it. But piling must be carefully done. It must be solid, fairly high so as to make an intense heat, and all particles must lie parallel, ranked up like wood, to secure solidity and exclude air. In coniferous growth, when brushing just precedes logging, it is common practice to fell the trees on top of the piles of brush, top and limb them, thus automatically piling the brush and saving labor. Burning toward evening limits danger of spreading the fire. In burning a large tract, start at the opposite side from which the wind blows. You thus escape the smoke and can go over the field a second time, "branding up" the piles to get a clean burn.

### The Brushing Season

The proper time to cut brush is in the late fall, in winters when there is little snow, and in early spring. Cut it when the foliage is off, or briefly, between cropping seasons. Experience shows no superiority in August brushing when labor costs are high and the crops need attention. A man can work to much better advantage with no foliage to bother his vision. He can get good footing on frozen ground and the frozen brush cuts better. The cost then is less, if hired labor is used, or the farmer himself can capitalize his own time to good advantage. Our studies indicate that it takes an average of from 20 to 30 hours per acre on light brush and a trifle over 60 hours on very heavy brush and windfalls. The increased value of a brushed and seeded acre is \$15 and upwards. The owner then can earn from \$2.25 to \$5 a day in increased land value by selling his time to himself at a season when labor is a drug on the market and his chores keep him close at home. Contract prices on brushing in normal times run from \$5 to \$6 per acre for light work to \$15 per acre for heavy work.

### SOWING GRASS SEED BETWEEN THE STUMPS

The land should be seeded if not to be stumped the same summer. The essentials of good seeding between the stumps are earliness, sufficient moisture, clean seed, and tillage of seedbed. Seeding on the snow is of questionable value to the land. We have

observed much better catches when the land has been stirred up wherever possible both before and after seeding. Tilling may be done with one section of a spring-toothed harrow; a disk; a harrow-toothed cultivator, or a balsam or other coniferous top. In some fields it is impossible to do anything owing to the number of stumps, but crude though the job may be, and though only a small fraction of the field is worked over, centers are thus established from which the grass will extend. Tillage is almost essential if grass is to head off the brush. Five or six pounds of grass seed per acre are sufficient. Two pounds each of alsike clover and timothy,  $\frac{1}{2}$  to 1 pound each of medium red clover and bluegrass, with a trace of white clover, gives good results. April sowing is usually better than May and June. Do not pasture till late fall and then lightly, the first season. Allowing the crop to head and ripen the first year will help to reseed the rest of the pasture.

On large areas it is sometimes desirable to use sheep for keeping back the second growth. This is successful provided the pasture is cross-fenced so as to make several rotation pastures. Shifting the sheep from one to the other keeps the brush cropped down, provides fresh feed, and keeps the sheep in good condition. Grass seed scattered behind the sheep will be worked into the soil by them and is second best to the plan outlined above.

### STUMP REMOVAL

The most of the stumping should ordinarily be done in the spring. Most economical results can usually be obtained immediately after the frost has left the ground, but the annual stumping season will extend until early in July, when hay harvest is at hand. We interpret the annual stumping season, then, as the time between seeding and haying. The ground is then full of moisture and the work is easier and much more economical than when it is dry. It often happens that the settler will have some time in the fall after the regular fall work has been finished and before freezing weather which might very profitably be devoted to stump removal.

The proper method of stump removal to use will depend largely on existing conditions such as the size, kind, and age of the stumps, the kind of soil, etc. Usually a combination of two or more methods is the most economical. A team on a straight pull should be used wherever it is possible to do so. This is the cheapest of all methods. In some cases, especially where the average diameter of the stumps is comparatively small, the block and tackle method works out very nicely. This is comparatively inexpensive. For larger stumps either explosives or a stump puller is used, or a combination of the two.

Explosives are used to best advantage in heavier soils and especially when the ground is wet. 20 per cent dynamite is usually best for stump blasting. It is cheaper than the higher grades and gives more of a slow, lifting action than a cutting or shearing effect like 40 or 50 per cent dynamite. Under exceptional conditions, however, where the soil is loose and dry, and especially if the stumps are green, 30 or 40 per cent might be more efficient.

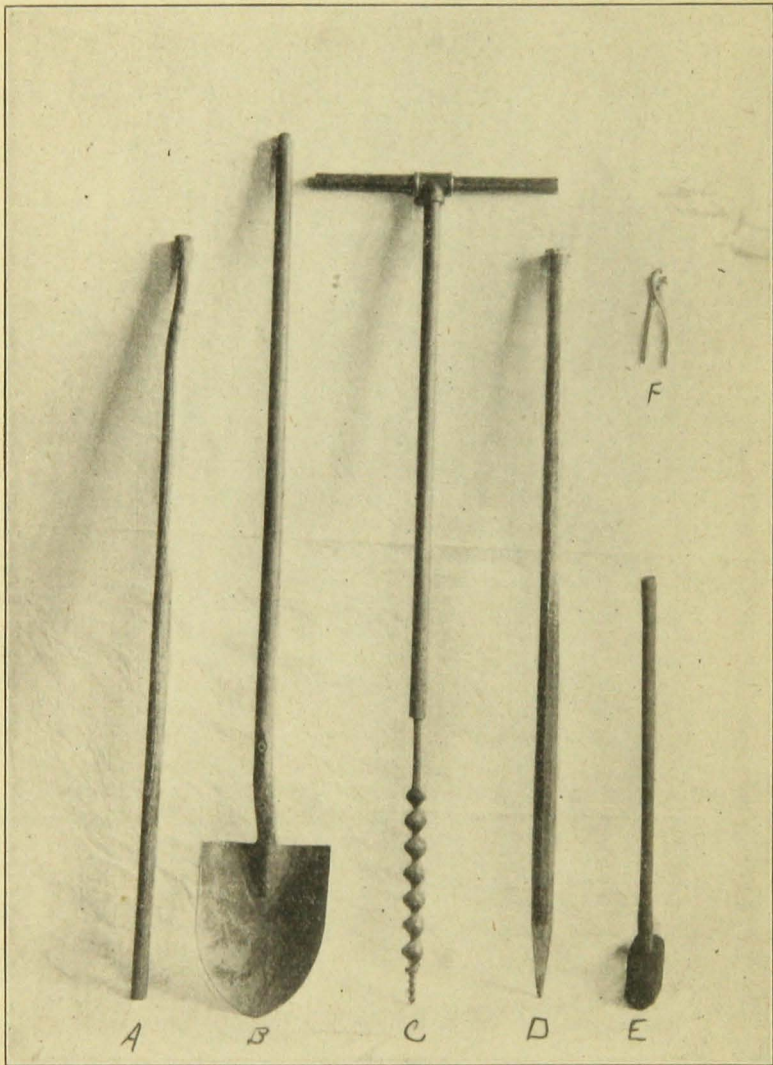

Fig. 2. Blasting Tools

- A. Wooden tamping stick
- B. Long-handled shovel
- C. Soil auger  $1\frac{1}{2}$  inches in diameter.
- D. Punch bar made of octagon tool steel  $1\frac{1}{2}$  inches in diameter and  $4\frac{1}{2}$  feet long
- E. 10-pound sledge for driving iron
- F. Cap crimpers and fuse cutters



Picric acid, a war-salvaged explosive, is being used to a certain extent, and is giving good satisfaction. Because the farmer pays only the cost of cartridgeing, transportation, and handling, it can be purchased comparatively cheap. It is somewhat more powerful than the ordinary dynamites used for stump blasting purposes, and is about as quick acting as 40 per cent dynamite.

The ordinary cap and fuse method of blasting is more commonly used than the electric method. The electric method has its advantages in that it is possible to fire more than one charge at the same time which is especially helpful where blasting large white pine stumps with hollow centers which require more than a single charge. Another advantage of the electric method is that there is less danger of a "hang fire" and the blaster has the time of firing under absolute control and therefore is less dangerous. The cap and fuse method is cheaper. The electric caps cost about five cents each more than the common caps.

Altho one man can get along very well at stump blasting, two or three can work together to much better advantage. Under general conditions an average of from 50 to 75 stumps per man is considered a good day's work.

There are two main classes of stump pullers: man-power pullers and horse-power pullers. We also find some large power pullers, but as yet they have not been adapted to the needs of the individual settler. The most practical type of horse-power pullers is the capstan type fitted with about 125 feet of  $\frac{3}{4}$ -inch cable on the drum. If more cable is desired it should be detachable extension cables in lengths of about 75 feet. It should also be fitted with an anchor cable of sufficient length to enable the team to pass between the machine and the anchor stump, one or two "take-ups" which make it possible to hitch a stump any place along the line of the main pull cable, and a strong root hook weighing not more than 50 pounds. The horse-power puller can be most efficiently operated with a crew of three or four men and a team. A crew of this size with a well equipped machine can pull about an acre of stumps in ten hours. Generally speaking, the rate of pulling will average about ten stumps per hour.

One-man pullers are built in several different styles and sizes. Generally speaking, the smaller sizes adapted for lighter pulling are more practical than the larger sizes, chiefly because of the difference in speed of operation.

Where there is a light soil especially when it is dry, a stump puller is usually cheaper than explosives alone. In order to use a puller effectively, however, it is very desirable that the stumps have solid tops which will not be cut off by the wire cable during the process of pulling. Under these conditions, and especially where the stumps are thick, comparatively small, and come out clean, a puller is a matter of economy. It must be borne in mind, however, that the matter of getting the stumps out of the ground is only a part of the job and that they must be piled and burned afterwards. Therefore the stump must be in such shape that it can be handled with a team after it is out of the ground. If the stump is too big to be handled in this way, it should be cracked with a small charge of dynamite either before or after pulling. This will

break it up and will also shake some of the dirt off the roots. It makes little difference whether this shooting is done before or after pulling. It takes about the same amount of explosive either way, but requires less skill in placing the charge if done before pulling.

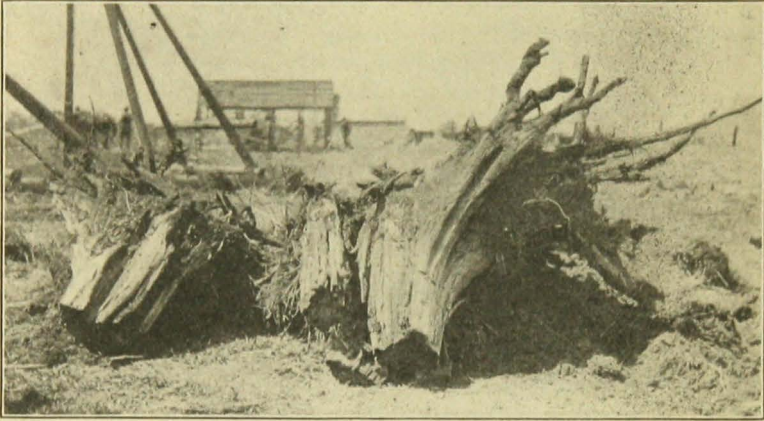

**Fig. 3. White Pine Stump**  
Pulled first and then cracked with dynamite

### PILING STUMPS

The most common way to dispose of the stumps after they have been pulled or blasted, is to pile them in the field and burn them. Where the stumps are comparatively small or where they have been pretty well broken up in the blasting operation, the best and cheapest method is to pile them with a team on a "decking chain." A small pile is started by skidding in the stumps and rolling them together. When the pile gets too high to roll the larger stumps on by hand, a long chain is thrown over the pile and the stumps are hitched so as to roll them on the pile when the team pulls on the chain.

A mechanical piler is used where there are large stumps that can not readily be handled any other way. A suitable piler may be built by the settler himself from timber on the farm, plus a small cash outlay for cables and other metal parts. The Conrath Home-made stump piler is quite popular in northern Minnesota.

The stumps should be piled in as solid and compact a manner as possible. A high and narrow pile will always burn better than a low, wide one. Two or three teams and an extra man make a good sized crew when piling with the decking chain, but a smaller crew can work to advantage. In order to operate the Conrath Piler to best advantage, there should be a crew of three teams and four men; one team to work on the piler while the other two teams skid stumps to the piles. The extra man operates the piler.



Fig. 4. Pile Finished with a Decking Chain

### BURNING STUMPS

The legal restrictions placed on burning hold true for stumps as well as for brush. A good job of stump removal and piling will usually leave but little dirt clinging to the roots. When this is the case, and especially if the stumps are dry, burning can be done practically any time after piling. If, on the other hand, stumps are removed and piled while still green, it is quite necessary that they be allowed to dry out for a while before attempting to burn them.

Where the pieces are so small that most of them can be readily handled by one or two men, numerous small fires are often started about the field and they are then fed by the continuous addition of stumps and roots, making it unnecessary to carry or haul any of the material for any great distance. The more common practice, however, is to make fewer and larger piles, and to clean up the field completely before any of the piles are fired. The proper time of the day to set fires and the general burning practice for burning a large number of piles are the same as for burning brush. Stump piles will very seldom burn up completely the first time. They must be repiled at least once or twice.

### REMOVING STONES

In some sections of Minnesota the land clearer has stones to contend with as well as stumps and brush. Where there are so many stones that the expense of clearing for the plow is prohibitive, the fields are usually seeded to grass and converted into permanent pastures. These pastures can usually be maintained quite satisfactorily by disking them occasionally and putting in new seed.

A large percentage of the best agricultural lands have some rock which must be disposed of. Stones that can be handled readily by

- BILL OF MATERIALS -

POLES

2	1/2" Skid logs 20' long	2	6" Post poles 17' 6" long
2	7" Yokes 9' long	1	6" Boom pole 3' long
2	6" Brace poles 21' long	1	5" Yoke 8" x 8" x 10' long
1	16" Drum pole 8' long		

IRONS

1	Beam Iron	3	1" x 10" bolts	1	Howl back Trip
1	Base	6	3" x 6"	1	Stump Trip
2	Straps	1	1" x 12"	1	Idler Pulley
1	Ring bolt 1" x 10"	1	1" x 9"	1	Rug
1	Cutter Jaw and Washer	1	3" x 7" Eye bolt	7	3" cable clips
1	Sheave Pin 1/2" x 7"	4	1/2" x 1 1/2" Lag Screws	2	3"
1	Sheave Pin 3/4" x 2 1/2"	2	3" x 3"	1	Cable 1/2" x 8 1/2"
6	1/2" x 1 1/2" bolts	2	Sheave Wheels - P-6	1	1/2" x 110"
1	1/2" x 2 1/2"	1	-P-7-	2	1/2" x 50"
6	1/2" x 8"	2	Windlass Strap Irons	1	Swivel Pulley

CONRATH STUMP PILER

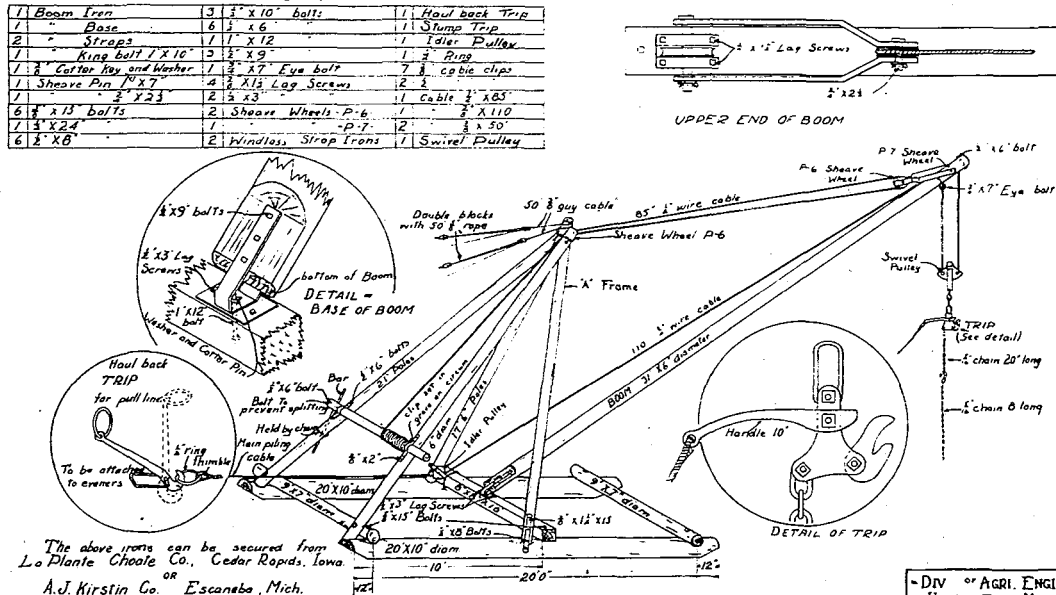

The above irons can be secured from  
 La Plante Chole Co., Cedar Rapids, Iowa.  
 A.J. Kirstin Co. or Escanaba, Mich.

- DIV OF AGRI. ENGINEERING -  
 UNIVERSITY OF MINNESOTA -  
 PLAN NO.      SHEET NO. -

**Fig. 5. Conrath Home-Made Stump Piler (Adapted from Wisconsin Bulletin No. 320)**  
 (Blue prints will be mailed free of charge on request)

one or two men are hauled off without much difficulty. For the larger ones it is necessary to have a specially made wagon or they must first be broken up with dynamite, or both. A wagon with axles hung low so that the bed rides only six or eight inches above the ground is very convenient for the purpose. The smaller stones can be loaded by one or two men and the larger ones can be rolled on with a team and chain. Different kinds of stone boats are also used to advantage. The wagon, however, has the advantage of hauling much more weight.

In connection with the operation of handling large rocks, dynamite may be used in three different ways:

"Mud-capping" perhaps is the most commonly used. By this method rocks may be broken very satisfactorily unless they are exceptionally large. The explosive material should be taken out of the cartridge and placed in a heap on the rock. It should be placed in a natural crevice if there is one, and as nearly in the center of the rock as possible. After the blasting cap has been inserted in the charge, it should first be covered with the paper wrappers from the dynamite cartridges and then with a thick layer of stiff mud.

For breaking very large boulders it is sometimes more economical to drill a hole in the rock into which the explosive material is placed. This method is called "block-holing." Less explosive is required than with the "mud-capping" method, but it requires more labor to prepare for, and to place the charge.

To insure most efficient results with either of the above mentioned methods, it is necessary that all dirt be removed from around the base of the stone. If it is entirely out of the ground it is ready to blast. If, however, it is partly or entirely buried, a charge of dynamite should first be placed under it to blow it out of the ground as a stump would be blown out (this sometimes breaks up the rock also); or a narrow trench may be dug all around it deep enough to reach the bottom of the rock. Which of these methods is used will depend largely on the relative cost of labor and the extra amount of dynamite required for the purpose. This last method of blasting is called "under-drilling."

Fifty or sixty per cent dynamite will give the best results for "mud-capping." For "block-holing" and "under-drilling" the lower grades may be used satisfactorily.



**Fig. 6. A Field Made Productive Before Removing the Stumps**  
The thing for a man with limited capital to do.



**Fig. 7. After Stumping and Before Plowing**

## LAND CLEARING CALENDAR

A Suggested Division of Time for the Year on a Cut-Over Farm  
Where Land Clearing is the Major Project

March 15-April 15.....	Spring Brushing
April 15-May 15.....	Planting Season
May 15-July 1.....	Spring Stumping
July 1-October 1.....	Harvest Season
October 1-November 1.....	Fall Stumping
November 1-December 15.....	Fall Brushing
December 15-March 15.....	Timber Harvest and Winter Brushing