

# Here's How

ST. PAUL CAMPUS  
DEC 28 1964  
UNIVERSITY OF MINNESOTA

**TO MAKE**

Step  
by  
Step

Slip  
COVERS

University of Minnesota  
Agricultural Extension Service



# Step by Step SLIP COVERS

WINONA M. STARKEY  
EXTENSION SPECIALIST  
IN HOME FURNISHINGS



ARE your chairs getting threadbare? Do you need a bit of color? Is everyday wear and tear spoiling the appearance of your upholstery? Maybe some slip covers are the answer.

Anyone who can handle a sewing machine, read and follow directions, and is endowed with some perseverance can make a good-looking slip cover. A slip

cover presents about the same problems that confront you in making a simple dress. Each chair, like each person, presents individual fitting problems, and, like a dress, loses its "chic" if it fails to fit.

Follow these simple step-by-step directions, **take your time, measure accurately, work carefully,** and success is at your finger tips.

## Preliminary Steps

### *Style, Chair Preparation, Measuring, and Fabric Selection*

1. Decide on **style** of cover (with or without flounce).
2. **Measure** chair to determine yardage. (See cutting chart, Figure 8.)
3. **Prepare chair.**  
Make any necessary repairs on springs, frame, or old cover.  
Clean to remove dust and soil that might come through new cover.  
Pad any wood trim to prevent wear on new cover.  
Place a muslin cover over plastic, leather, or mohair chairs to prevent cover from slipping.

#### 4. **Select the fabric.**

Look for labels showing information on dye, fiber, and shrinkage.

Choose closely woven fabrics, for they usually wear well and do not stretch out of shape.

Check grain line on printed fabrics.

Remember that large designs and stripes present matching problems and take more yardage.

Select a color that harmonizes with your other colors.

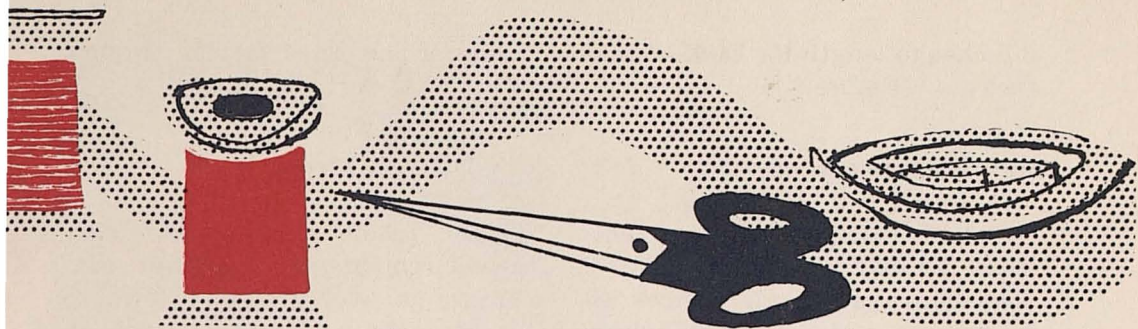

## Measuring and Cutting Steps

### *How To Measure for Yardage, Prepare Fabric, and Make Cording*

Before shopping for your fabric, determine the yardage you will need in different widths of material. Slip cover fabrics are made in 36-inch, 48-inch, or 54-inch material.

Measure chair and then cut paper sections to scale for each piece. Use a scale of one inch equals one foot. Write name of piece and actual measurements on each section. Also indicate the top of each piece.

### *How To Measure*

Follow the main lines of the chair in taking all measurements.

#### **Back Piece**

Take measurements indicated by solid red lines and add a 1-inch seam allowance at each edge. (Figure 1)

#### **Inside Back and Seat Cover**

A big rectangle. Add 1 inch at each side for seam allowance and

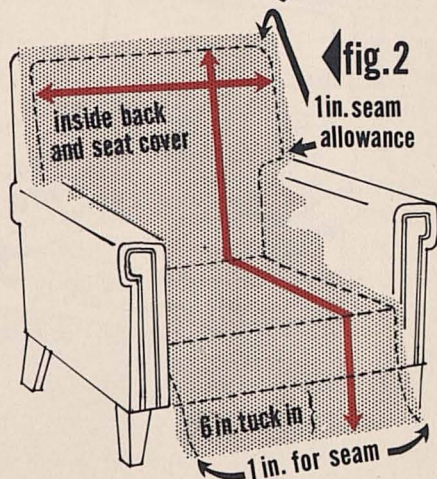
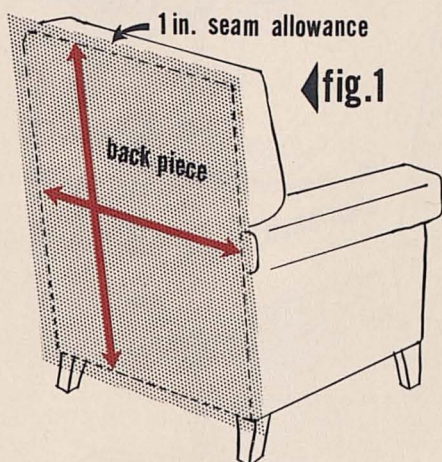

6 inches to length for back-of-seat tuck-in. (Figure 2)

### Outside Arm Pieces

Take measurements as indicated by red lines on Figure 3. Add 1-inch seam allowances on four sides. Cut both a right and left piece. Note: Match design if

using a patterned fabric. (Figure 3)

### Inside Arm Pieces

For inside arm pieces, start measurement at outside arm curve, go over arm and down to inside seat. Add 3-inch tuck-in. Width is figured from front arm to outside back piece plus 1-inch seam allowances at front and back. Cut two pieces. (Figure 4)

### Top Band

Top band width is thickness of chair back. It starts and ends at seams where arm joins chair. It is a continuous piece with no seams. Make usual 1-inch seam allowances on four sides. (Figure 5)

### Front Arm Pieces

Measure from top to bottom and side to side. Use widest and longest measurements and add seam allowances on all sides. Cut

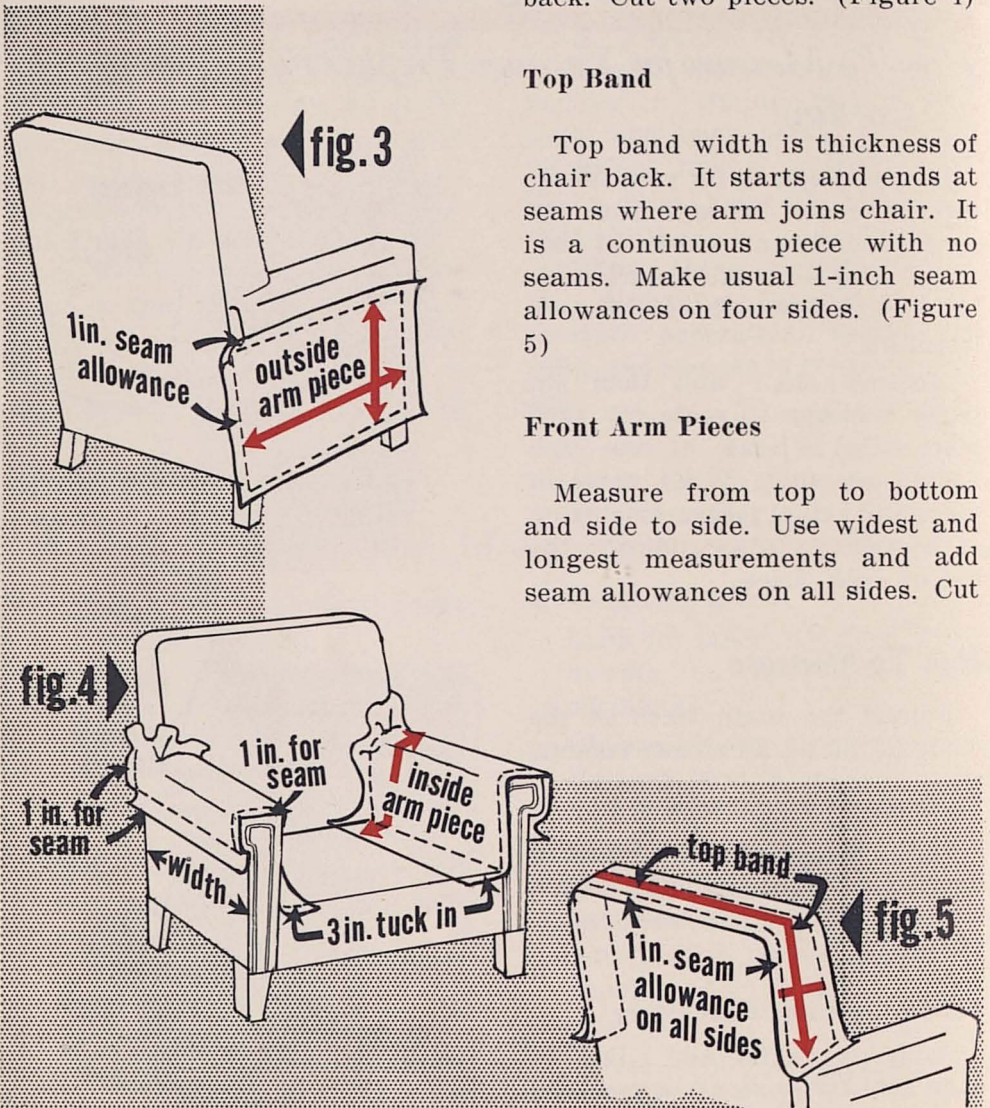

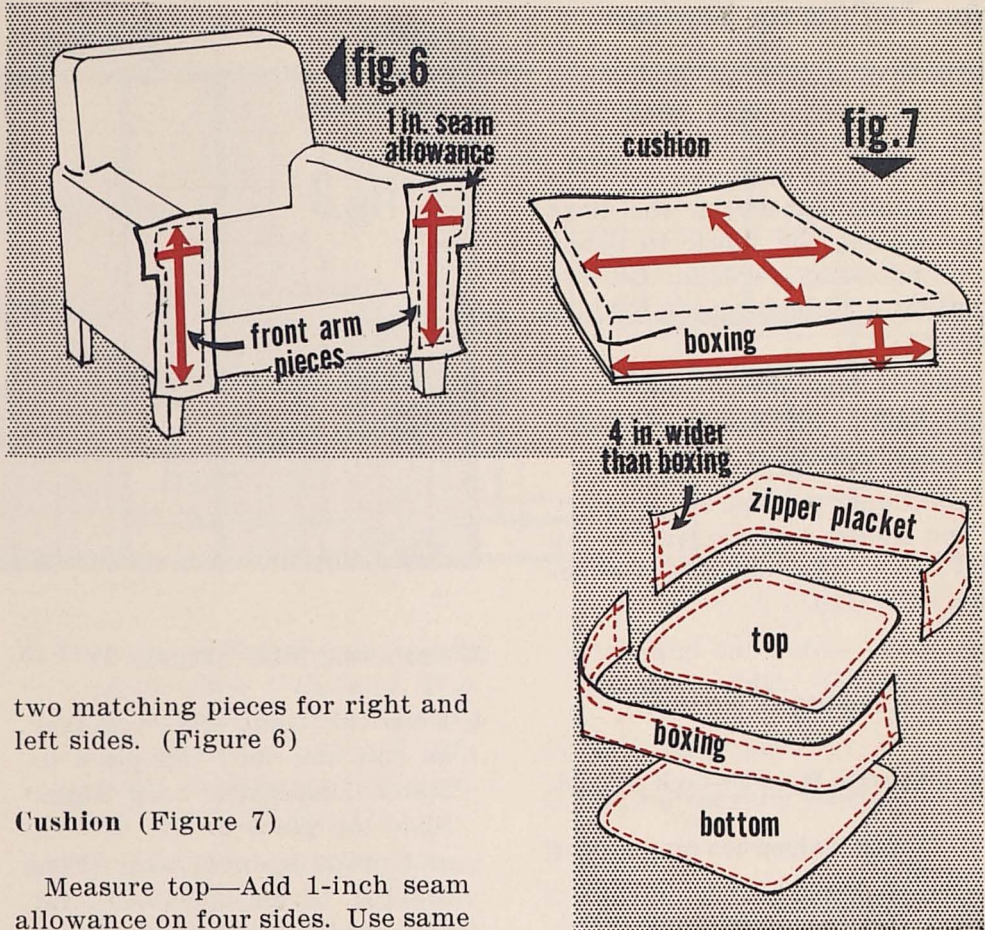

two matching pieces for right and left sides. (Figure 6)

### Cushion (Figure 7)

Measure top—Add 1-inch seam allowance on four sides. Use same measurements for bottom of cushion.

Boxing and zipper placket—Pin zipper to boxing of cushion. Add 1-inch seam allowance at ends. Add 4 inches to boxing width for application of zipper.

Plain boxing—Measure remaining distance around pillow and add 1-inch seam allowance on all sides.

### Prepare the Fabric

- Straighten end by pulling thread, and cut.

- Shrink fabric if it has not been preshrunk.
- Chalk and cut all pieces to closest rectangles, following grain line of fabric. (Use your cutting chart, Figure 8.)

Check and recheck to be sure that you have allowed for all seams and tucks. (Pin name of piece at top and on right side of fabric.)

## How To Plan for Yardage

Draw to scale a piece of fabric approximately 5 to 6 yards long and 36 inches, 48 inches, or 54 inches wide, as in Figure 8. Juggle your sections between the lines representing the fabric to determine necessary yardage. Be sure to allow a 30-inch square for bias cording.

You will also want to determine yardage for other widths of fabrics before you actually shop.

Additional yardage is necessary if you choose a fabric with an up and down, right and left, and repeat of design.

## Make Cording Strip

Cut bias strip from 30-inch square.

1. Be sure all sides are on straight of fabric.
2. Fold into triangle. (Figure 9)

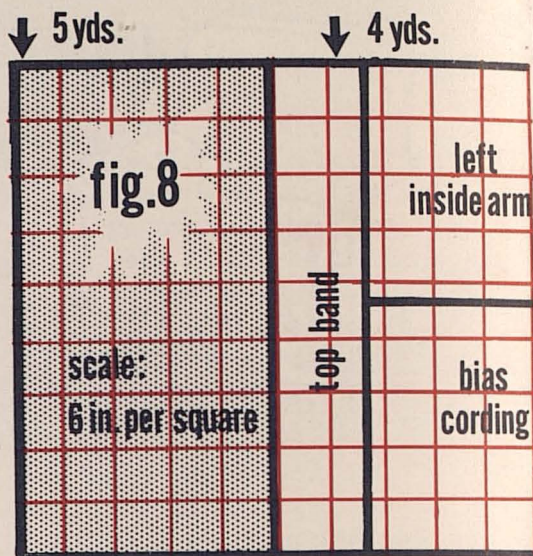
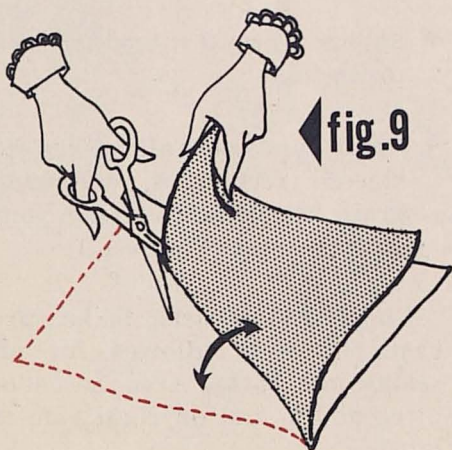

3. Cut along fold. (Figure 9)
4. Keep the right sides together as cut, and turn top piece to match lengthwise warp edges. Slide top piece to left  $\frac{1}{2}$  inch and make  $\frac{1}{2}$ -inch seam (Figure 10). Press open and trim off points. See detail.

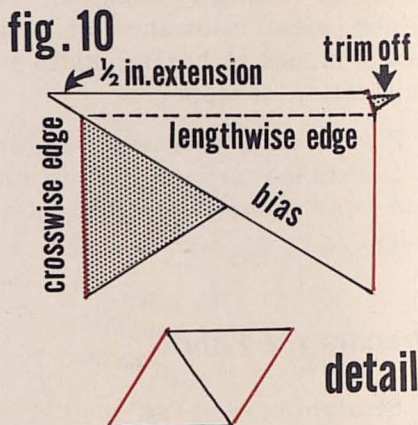

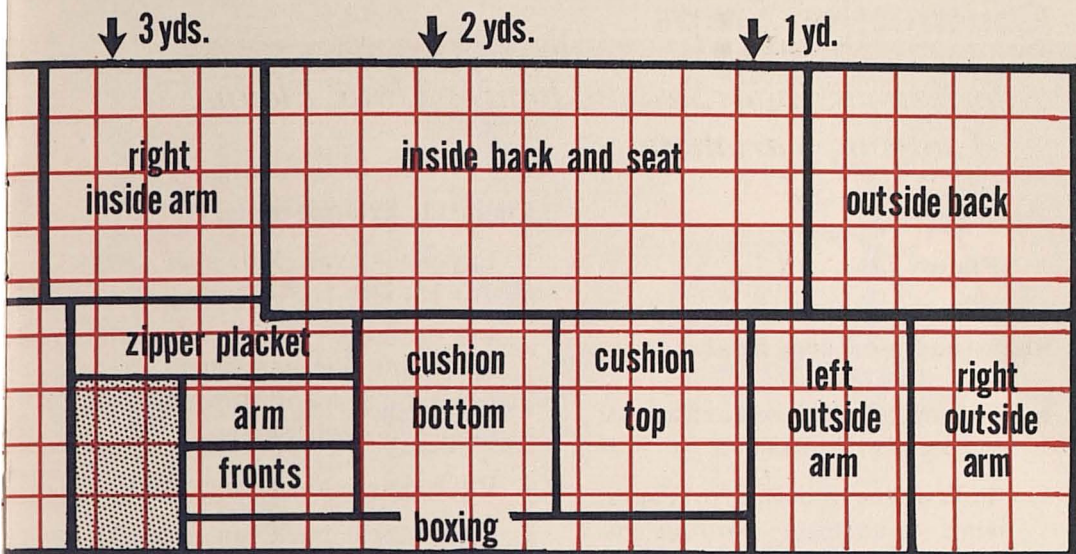

5. Roll in cylinder and match straight edges (red lines, Figure 11). Slide edges so that  $1\frac{1}{2}$  inches extend at each end. Pin in place and sew  $\frac{1}{2}$ -inch seam. Press open. (Figure 11)
6. You now have a cylinder. Use  $1\frac{1}{2}$ -inch measuring guide on scissors or other measuring de-

vice, and cut entire bias strip the same width. (Figure 12)

**Cover Cord (Figure 13)**

1. Use a preshrunk washable cord.
2. Make all cording at one time.
3. Use a double-edged cording foot on sewing machine.

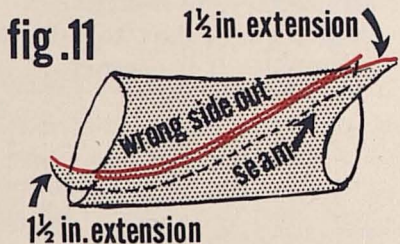

fig. 11



fig. 12

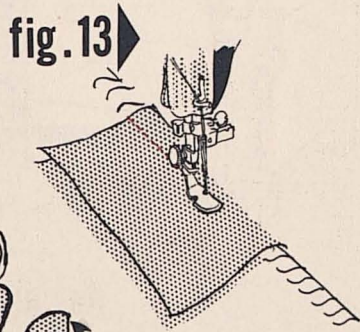

fig. 13

# Construction Steps

## *Arm Sections, Inside Sections, Joining Units, Flounce, Cushions, Variations*

### **Arm Section**

(Figure 14)

#### **Shape and cord arm front.**

1. Pin arm front rectangles to arm fronts of chair.
2. Chalk shape of both arm fronts, using upholstery cording on chair as guide. Then cut 1 inch outside of chalk line.
3. Sew cord on chalk line around edge of each arm front. (Do not cord bottom edge.) Clip on curves. (See detail, Figure 14.)

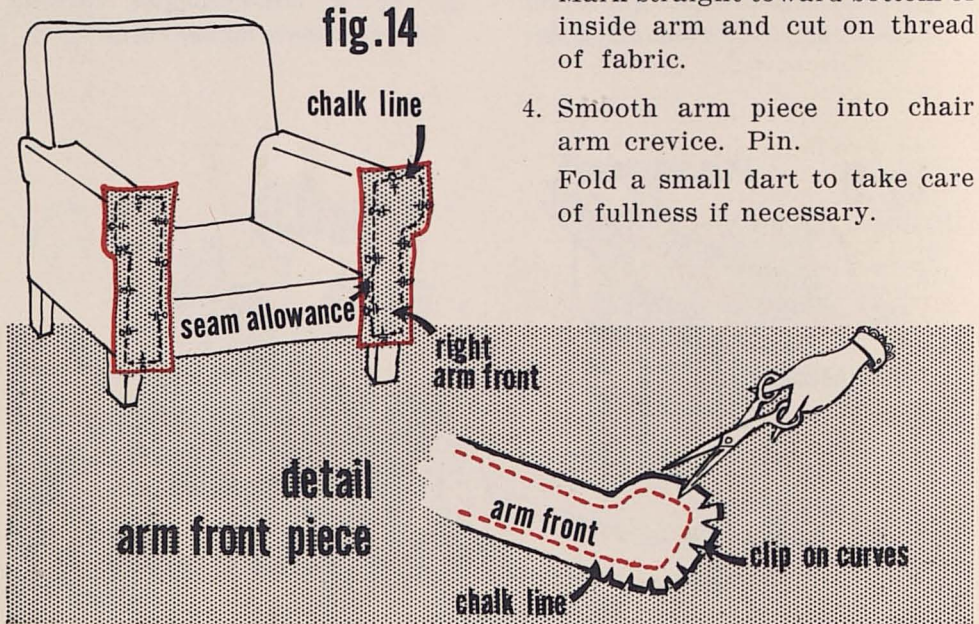

#### **Fit inside arm piece.**

1. Lay piece over chair arm. (Figure 15)  
Leave 1-inch seam allowance below outside arm curve.  
Let 1-inch seam allowance extend over arm front.
2. Pin to keep fabric on grain line.
3. Fold fabric back, as in detail, Figure 15, where chair arm and inside back join.  
Make chalk mark at edge of chair back.  
From this point on the fold make chalk mark to edge of fabric.  
Cut to within 3 inches of inside chair back on this line.  
Mark straight toward bottom of inside arm and cut on thread of fabric.
4. Smooth arm piece into chair arm crevice. Pin.  
Fold a small dart to take care of fullness if necessary.



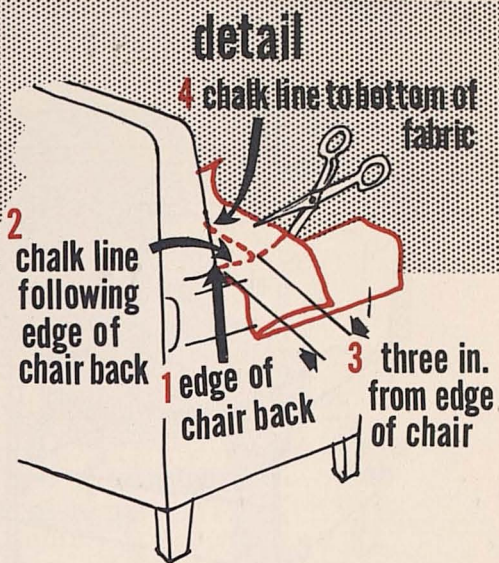
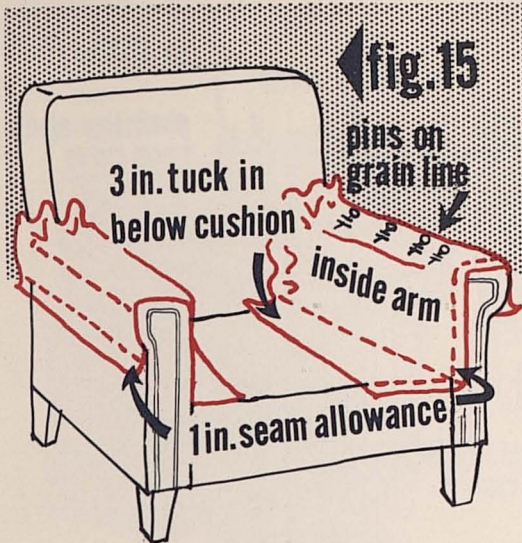

### Fit outside arm piece.

1. Fold a seam allowance on top edge and press. (See detail, Figure 16.)
2. Place over inside arm piece. (Figure 16)
3. Pin at front, smooth toward back and pin.
4. Pin seam under arm curve.

### Fit arm front. (See detail.)

1. Pin corded arm front in place. (Pin to fabric but not to chair.)
2. Remove entire arm section from chair and stitch.  
Top stitch long seam to join inside and stitch. (A to B, Figure 16)  
Make dart at back of arm if necessary. (Figure 16)  
Top stitch arm front to side pieces from C to D. (Figure 17)
3. Make other arm section.

Cord front side of top band and top and sides to back piece.

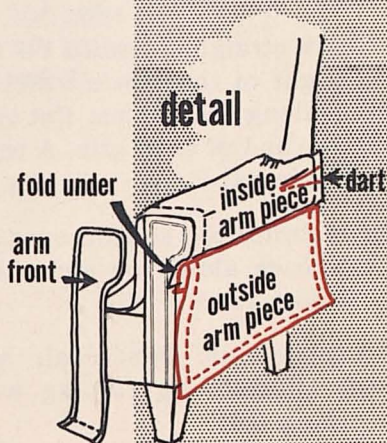
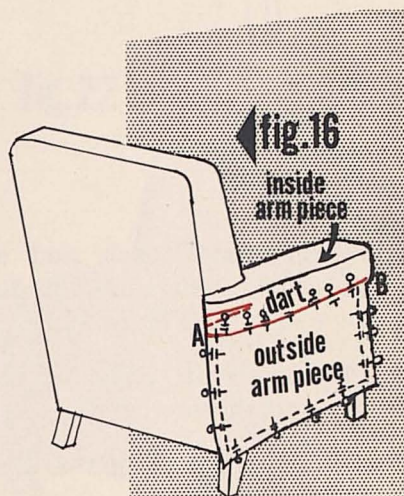

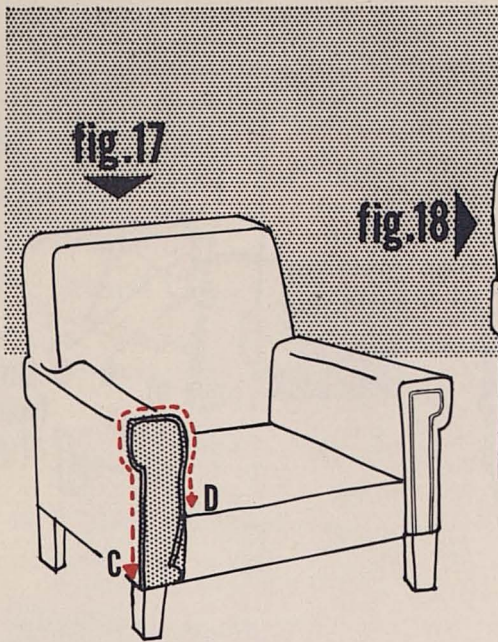
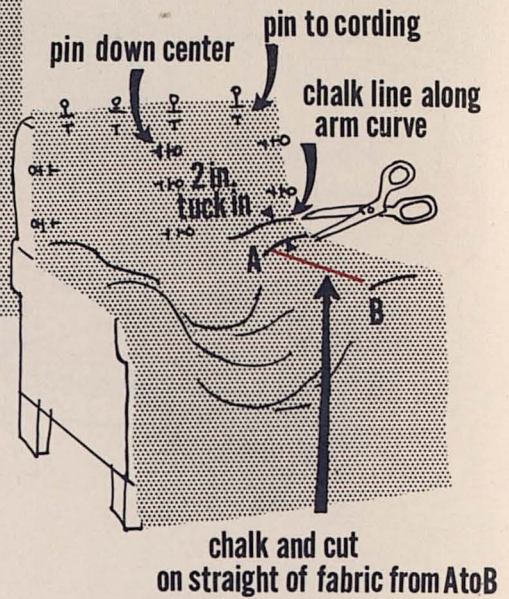

fig. 18



### Inside Section

- Center inside back and seat piece on chair and pin down center. (See Figure 18.)
- Pin firmly in place at chair top and sides.
- Chalk along arm curves, allowing 2-inch tuck-in.
- Chalk straight forward on the straight of the fabric which is laid along chair arms. Cut only to the end of each arm, A to B. (Figure 18)
- Pin corded top section over inside back along top and sides. (Figure 19)

Remove unit from chair and top stitch along cording with cording foot.

fig. 19

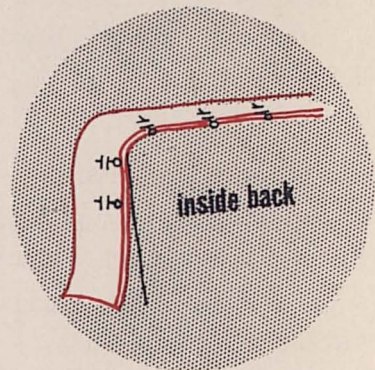

- Put unit back on chair and anchor at top and sides.
  1. Bring fabric 1 inch below bottom edge of chair.
  2. Allow enough tuck-in at sides to fit into spring of

**fig.20**

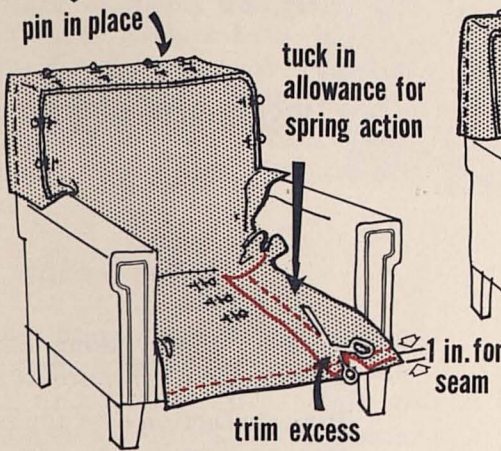

**fig.21**

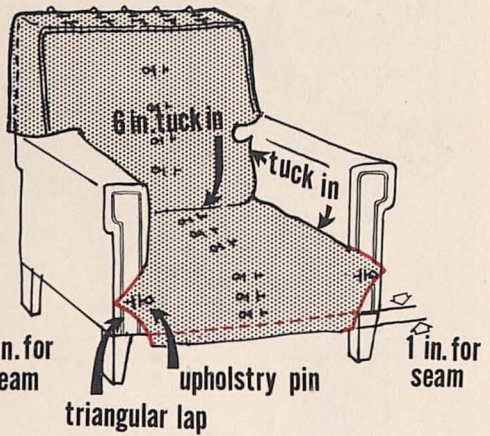

chair. (Figure 20) Cut off any excess.

3. Anchor fabric in from center of chair seat with upholstery pins. (Figure 21) Push fabric at sides down into spring tuck-in crevice. (This will create a triangular lap.) Pin lap over front arm upholstery with an upholstery pin.
4. Tuck in extra fabric along sides and back of chair seat.
5. Leave inside and seat section pinned to chair and replace both arm sections.

Slip triangular lap under corded arm front which was left open when you made the arm sections. (Figure 22)

Pin open section of arm front over lap. (Figure 22)

**fig.22**

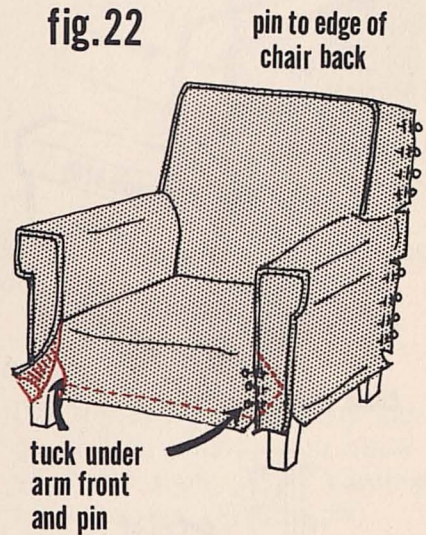

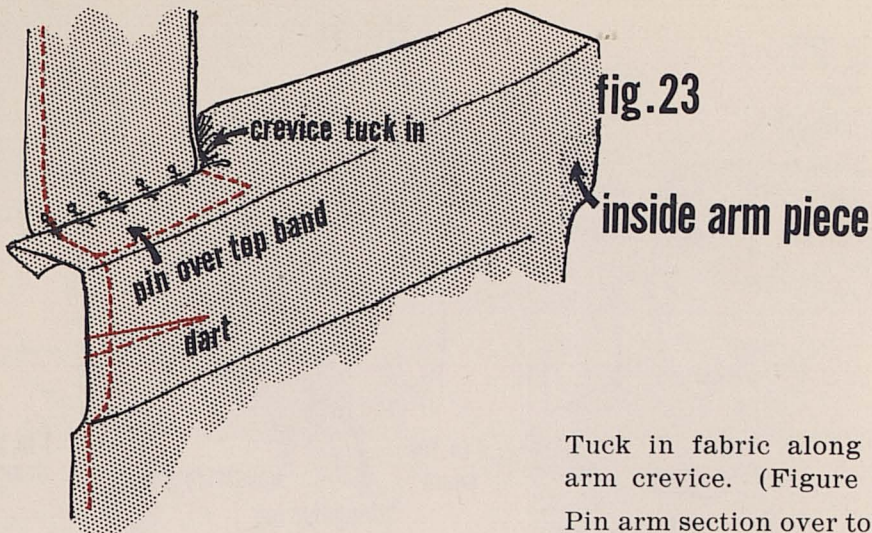

fig.23

inside arm piece

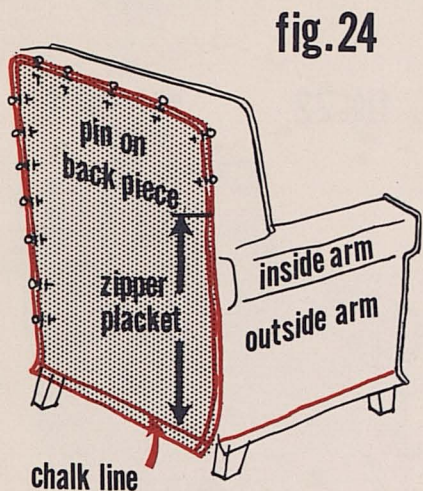
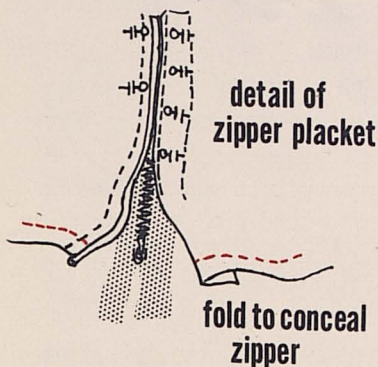

fig.24

chalk line



Tuck in fabric along chair arm crevice. (Figure 23)

Pin arm section over top section and anchor to edge of chair back. (Figure 23)

Pin corded back piece in place over seam allowance to top band and side pieces (Figure 24). Do not pin to chair.

Unpin back seam for zipper. Make opening higher than chair arm. (Figure 24)

Chalk fabric along bottom edge of chair if not using a flounce.

Insert zipper in placket and pin so that one side of teeth meets cord stitching and side of back forms  $\frac{1}{2}$ -inch fold over teeth to conceal closing. Leave 1-inch seam allowance below end of zipper. (Detail, Figure 24)

6. Remove slip cover.

### Joining Slip Cover Units

1. Top stitch unstitched seams of front arms. (Figure 25)

2. Stitch seat tuck-in seams with 1-inch plain inside seam. (Figure 26)

Start at front of chair and stitch to back, A to B.

Start from arm back to end of first stitching, C to B.

3. Top stitch corded back piece and attach zipper. (Figure 27)

## To Make Flounce

Measure distance around chair and add allowances for seams, hem, and pleats. Stitch plain 1-inch hem at bottom. Make pleats. Cord top. Re-pin corded flounce on slip cover. Turn seams down as you pin. Remove cover and top

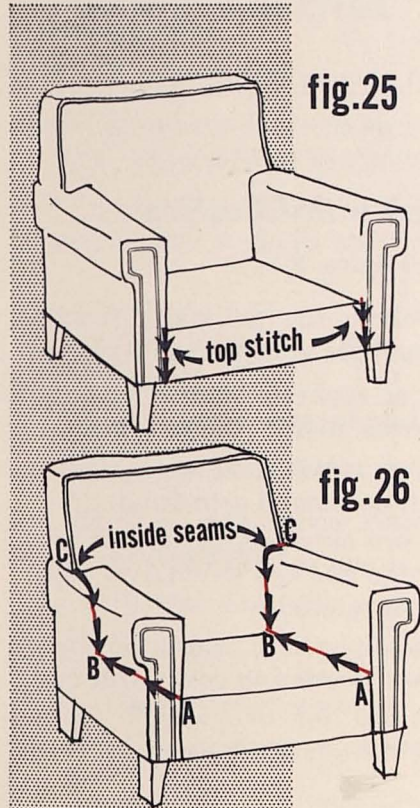

fig.25

fig.26



fig.27

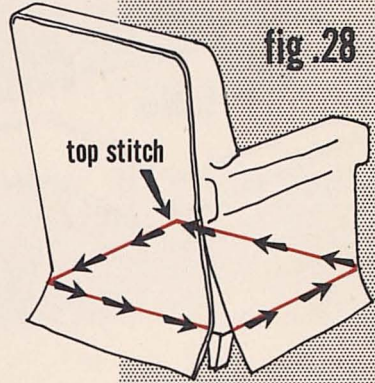

fig.28

stitch, and add hook and eye at cord.

## Cushion

1. Cut top and bottom exact size of cushion plus a seam allowance of 1 inch. Apply cording on seam line. (Figure 29)
2. Measure cushion for boxing. Center zipper on back of cushion, and pin in place. Measure distance around pillow from ends of zipper. Add 2 inches. Measure depth of pillow. Add two-inch seam allowance. Cut lengthwise of material. Measure length of zipper and add 2 inches. Cut the zipper section

fig.29

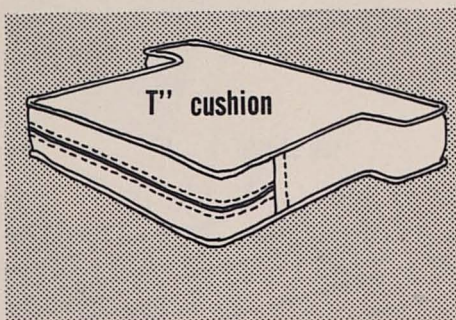
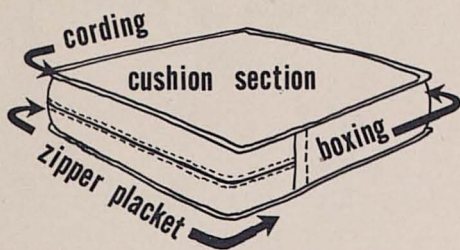

1½ inches wider than the other section of boxing.

3. Sew zipper in placket strip. First, cut placket strip of boxing in half lengthwise. Make ¼-inch turn to wrong side, on side of one length. Pin to zipper tape along edge of teeth. Turn ¾ inch to wrong side along one edge of the other strip. Pin to other edge of zipper teeth. Stitch both strips to zipper. Sew one end of placket to end of boxing strip.
4. Pin boxing to cushion sections with placket centered at back. (Figure 29) Hold boxing side toward you. When boxing meets other end of placket, pin, seam, and stitch. Stitch top and bottom to boxing.

## Variations

### *For Other Types of Chairs*

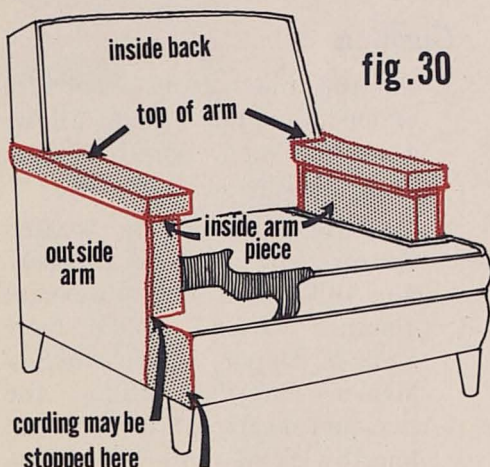

T-section - inside back and seat piece [add or piece]

### *Chair with T Cushion*

(Figure 30)

Follow the general directions, with these exceptions:

1. Cut separate pieces for top of arms, and cord the edges.
2. Cut inside arm piece to continue around arm front.
3. Cord outside arm piece at front edge and top stitch over inside arm piece.
4. Allow added width on inside arm section to cover arm front.
5. Allow for or piece T section width on inside back.

## Wing Chair

(Figure 31)

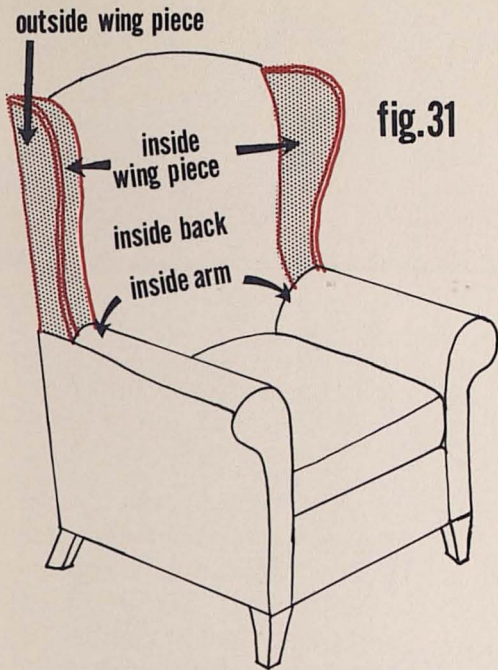

1. Cord outside edge of inside wing piece.
2. Top stitch inside wing piece over outside wing piece.
3. Top stitch wing over inside arm without cording.
4. Use plain inside seam to join inside back and wing.
5. Allow for the wing tuck-in, both in cutting and stitching.

## Finishing Touches

- Press cover before placing on chair.
- Check seam lines to be sure that they follow construction lines on the chair, especially at the points where the arms meet the chair.
- Keep tuck-in allowance in place by pushing folds of tissue or newspaper down between chair arm and seat.

## Evaluate Your Cover

Does it fit snugly with no wrinkles?

Does it belong to the room in which it is used?

Is it made of well-chosen material and suited to the furniture in texture, color and design?

Are the seams carefully made?

Has each section been cut on the grain of the fabric?

Is the placket inconspicuous?

Is the flounce parallel to the floor?



Publications such as this are one of the educational services provided by the University of Minnesota Agricultural Extension Service. These services to the people of Minnesota are financed jointly by your county, state, and federal governments. Agents at your county extension service office can provide help in many problems. They work in agriculture, home economics-family living, 4-H, marketing, and community and resource development. Their services are available to all residents of Minnesota. Publications on some 500 subjects and a list of available publications are available at your County Extension Office or from the Bulletin Room, University of Minnesota, St. Paul, Minnesota 55101.

Adapted for Minnesota use by Myra Zabel, extension specialist, home furnishings, from material prepared by Winona M. Starkey, extension specialist in home furnishings, Kansas State University, and published as circular 271 by Kansas State University Extension Service, Manhattan, Kansas. Published in furtherance of cooperative extension work in agriculture and home economics, acts of May 8 and June 30, 1914, in cooperation with the U. S. Department of Agriculture. Luther J. Pickrel, Director of Agricultural Extension Service, University of Minnesota, St. Paul, Minnesota 55101.

5M—11-64