

**Design of a constant-voltage-source to array of sensors to  
optimize heart-beat detection**

A THESIS

SUBMITTED TO THE FACULTY OF THE GRADUATE

SCHOOL

OF THE UNIVERSITY OF MINNESOTA

BY

SAYALI A. KULKARNI

IN PARTIAL FULFILLMENT OF THE REQUIREMENTS

FOR THE DEGREE OF

MASTER OF SCIENCE

Advisors: Dr. Jing Bai & Dr. Debao Zhou

February 2014

©Sayali Kulkarni, 2013

UNIVERSITY OF MINNESOTA

## **Acknowledgement**

I would first like to thank my advisors, Dr. Jing Bai and Dr. Debao Zhou for giving me the opportunity to work under their guidance and for their continuous support and help throughout my study. It was a great experience working with Dr. Bai and Dr. Zhou.

I appreciate the time and effort from Dr. Mohammed Hasan for serving on my thesis committee. I want to extend my thanks to Dr. Imran Hayee for allowing me to use the EE 2111 lab for circuit testing.

My appreciation also goes to the Department of Electrical Engineering (EE) at the University of Minnesota Duluth (UMD) for all the support during my graduate study. I acknowledge the research assistantship (RA) by the research grant from the Whiteside Institute of Clinical Research and the teaching assistantship (TA) from the EE department.

Most especially to my father Ashwinikumar Kulkarni and mother Arati Kulkarni for always being there for me.

## **Abstract**

In this project, we designed a circuit to capture the signal from the skin-like heart beat sensor and convert it to an electrical signal. The circuit is one part of the optical heart beat detection system which also includes the skin-like optical sensor array and the laser source and data processing unit. The circuit will be connected with the sensor array and be able to detect the sensing signal at each dot of the array. The sensor system could also be applied to contact form detection in other biomedical system.

The sensing element of the sensor system is currently under investigation by our collaboration group in MIE department. The circuit we designed in this project will power the circuit with a sequence of pulses and the output should be distinguishable corresponding to each pulse. The circuit is expected to be able to handle single input and multiple outputs. Testing results show that the prototype of our circuit built on breadboard can meet the design criteria with the defect of non-zero offset at the output when the circuit is not powered. This defect will be a key problem that should be solved in the continuous effort of this research. Based on the breadboard circuit, the final circuit will be fabricated through CMOS technology on 3mm×3mm silicon chip in order to accommodate the real application of the sensor.

## Table of Contents

|   |    |
|---|----|
| Acknowledgement.....  | i  |
| Abstract.....   | ii |
| List of figures.....  | v  |
| Chapter 1 Introduction .....                                      | 1  |
| 1.1 Background .....  | 1  |
| 1.2 Motivation .....  | 4  |
| 1.3 Scope .....   | 5  |
| Chapter 2 Theoretical Background on Circuit Design .....          | 7  |
| 2.1 How to measure heartbeats?.....                               | 7  |
| 2.1.1 Manual method (Taking Pulse).....                           | 7  |
| 2.1.2 Using stethoscope .....                                     | 8  |
| 2.1.3 Monitor method .....  | 9  |
| 2.2 Sequence of pulse generation.....                             | 12 |
| 2.2.1 SIPO.....   | 13 |
| 2.2.2 D Flip-Flop.....  | 14 |
| Chapter 3 Power Supply Circuit Design for the Sensor System ..... | 16 |
| 3.1 Expected function of the circuit .....                        | 16 |
| 3.2 Components used in the circuit .....                          | 18 |
| 3.2.1 D Flip-Flop,.....   | 18 |
| 3.2.2 Diode.....  | 19 |
| 3.2.3 Capacitor .....   | 20 |
| 3.2.4 Resistor .....  | 21 |
| 3.2.5 Breadboard .....  | 22 |
| 3.3 Circuit design methodology .....                              | 23 |
| 3.4 Circuit design with Multisim software.....                    | 24 |
| 3.5 Layout of circuit for PCB fabrication by EAGLE software.....  | 30 |

|           |   |    |
|-----------|---|----|
| 3.5.1     | Schematic Capture .....                         | 30 |
| 3.5.2     | Layout Editor .....                             | 32 |
| 3.6       | Gerber Files Generated.....                     | 33 |
| 3.6.1     | Top Copper Layer .....                          | 34 |
| 3.6.2     | Bottom Copper Layer .....                       | 35 |
| 3.6.3     | Top Solder Mask.....                            | 37 |
| 3.6.4     | Bottom Solder Mask .....                        | 38 |
| 3.6.5     | Top Silkscreen Layer .....                      | 39 |
| 3.6.6     | Drill File.....                                 | 40 |
| Chapter 4 | Testing of circuit.....                         | 41 |
| 4.1       | Testing equipments used .....                   | 41 |
| 4.1.1     | Function generator .....                        | 41 |
| 4.1.2     | Power supply.....                               | 42 |
| 4.1.3     | Digital Storage Oscilloscope (DSO).....         | 42 |
| 4.2       | Breadboard circuit .....                        | 43 |
| 4.3       | Testing Setup.....                              | 44 |
| 4.4       | Expected Results .....                          | 45 |
| 4.5       | Testing Procedure.....                          | 45 |
| 4.6       | Testing oscilloscope screenshots (2Hz) .....    | 46 |
| 4.6.1     | Checking the time of pulse .....                | 46 |
| 4.6.2     | Checking the amplitude of pulse.....            | 47 |
| 4.6.3     | Checking the sequence of pulses .....           | 49 |
| 4.7       | Testing oscilloscope screenshots (20 kHz) ..... | 50 |
| 4.7.1     | Checking the time of pulses .....               | 50 |
| 4.7.2     | Checking the amplitude of pulses .....          | 51 |
| 4.7.3     | Checking the sequence of pulses .....           | 52 |
| 4.8       | Summary of testing results.....                 | 53 |
| Chapter 5 | Conclusions and future work.....                | 54 |
| 5.1       | Conclusions .....                               | 54 |

|     |                   |    |
|-----|-------------------|----|
| 5.2 | Future Work ..... | 55 |
|     | References .....  | 56 |

## List of figures

|  |    |
|--|----|
| Figure 1 System Design of Laser-based stethoscope [1].....                           | 3  |
| Figure 2 Testing of the prototype of the system on the dummy human body [1].....     | 4  |
| Figure 3 (a) Taking pulse at wrist (b) Taking pulse at neck.....                     | 8  |
| Figure 4 Heartbeat Testing using Stethoscope.....                                    | 9  |
| Figure 5 ECG [12].....   | 10 |
| Figure 6 Different parts of body along with the signals they give out.....           | 11 |
| Figure 7 Four stage SIPO register.....   | 13 |
| Figure 8 Circuit diagram of SIPO register.....                                       | 14 |
| Figure 9 Outputs required.....   | 17 |
| Figure 10 Logic Diagram of D Flip-Flop.....  | 19 |
| Figure 11 Diode 1N4148 diagram and symbol.....                                       | 20 |
| Figure 12 Capacitor diagram and symbol.....  | 21 |
| Figure 13 Resistor diagram showing color code and symbol.....                        | 22 |
| Figure 14 Breadboard.....  | 23 |
| Figure 15 First circuit designed using multisim.....                                 | 26 |
| Figure 16 Multisim results showing voltage versus time waveforms of the circuit..... | 27 |
| Figure 17 Second (Final) circuit using multisim.....                                 | 28 |
| Figure 18 Multisim results showing voltage versus time waveforms of the circuit..... | 29 |
| Figure 19 Circuit Schematic in EAGLE.....  | 31 |
| Figure 20 PCB Layout in EAGLE.....   | 33 |
| Figure 21 .cmp file.....   | 35 |
| Figure 22 .sol file.....   | 36 |
| Figure 23 .stc file.....   | 37 |



|   |    |
|---|----|
| Figure 24 .sts file.....  | 38 |
| Figure 25 .plc file.....  | 39 |
| Figure 26 .ncd file.....  | 40 |
| Figure 27 Function Generator.....   | 42 |
| Figure 28 Power Supply.....   | 42 |
| Figure 29 DSO.....  | 43 |
| Figure 30 Breadboard circuit.....   | 44 |
| Figure 31 Testing setup.....  | 45 |
| Figure 32 Oscilloscope screenshots showing width of pulse is 500ms at 2Hz<br>frequency.....       | 47 |
| Figure 33 Oscilloscope screenshots showing amplitude of pulse is 4.8V at 2Hz<br>frequency.....    | 48 |
| Figure 34 Oscilloscope screenshots showing sequence of pulses at 2Hz frequency.....               | 49 |
| Figure 35 Oscilloscope screenshots showing width of pulse is 50us at 20 kHz<br>frequency.....     | 50 |
| Figure 36 Oscilloscope screenshots showing amplitude of pulse is 50us at 20 kHz<br>frequency..... | 51 |
| Figure 37 Oscilloscope screenshots showing sequence of pulses at 20 kHz frequency....             | 52 |

# Chapter 1 Introduction

In this chapter, we introduce the background and scope of the current research. The current research is one part of continuing effort of the laser-based heartbeat detection project. The heartbeat detection system has been designed and the prototype has been built in previous research. The ongoing research aims to make the whole heartbeat detection system more compatible and portable. A key issue to overcome in this effort is to make a light and handy heartbeat detection sensor. The sensor adopted in the prototype system is an optical sensor while the whole sensing system includes a laser, a linear optical position sensor and associated DAQ unit. Even with the smallest optical sensor available in the market, the detection system still has to be discrete and not easy to integrate. Therefore, we proposed to develop another sensing system, which is the skin-like pressure sensing system composed of the skin-like sensor and data acquisition (DAQ) circuit. The thesis work presented focuses on the design and testing of DAQ circuit. The skin-like sensor is currently under study by our collaborating collaboration group in MIE department. Next, the background and scope of current research will be presented in detail.

## 1.1 Background

The research is based on the laser-based heartbeat detection system developed in the previous research by our research group [1]. In this laser based system, the heart

signal is correlated to the scattering pattern of a laser beam reflected from the reflective mirror attached to the patient's chest. Vibration of the diaphragm is generated by the acoustic pressure from the heartbeat. With the aid of a time-resolved position sensor, the reflected optical spots can be detected and displayed as continuous waveforms in the time-domain. Optical signal processing and mathematical analysis techniques were applied to classify the heart signals and transform them to the frequency-domain to reveal more details on heart sound murmurs. The system design is shown in Figure 1. The reflective mirror with double-side fashion tape on the back will be attached to the chest skin of the patient. Movement of the mirror with the chest is produced by the acoustic pressure from the heartbeat transmitted through chest tissues and skin. The light beam from the laser source arrives at the chest mirror and is reflected towards the linear optical position sensor. The movement of the optical spot reflected from the chest skin can be detected by the two-dimensional (2D) linear position sensor module and recorded as the visible vibration waveform in the time-domain by the data acquisition (DAQ) system of the sensor. Such movement is directly correlated to the vibration amplitude of the chest.

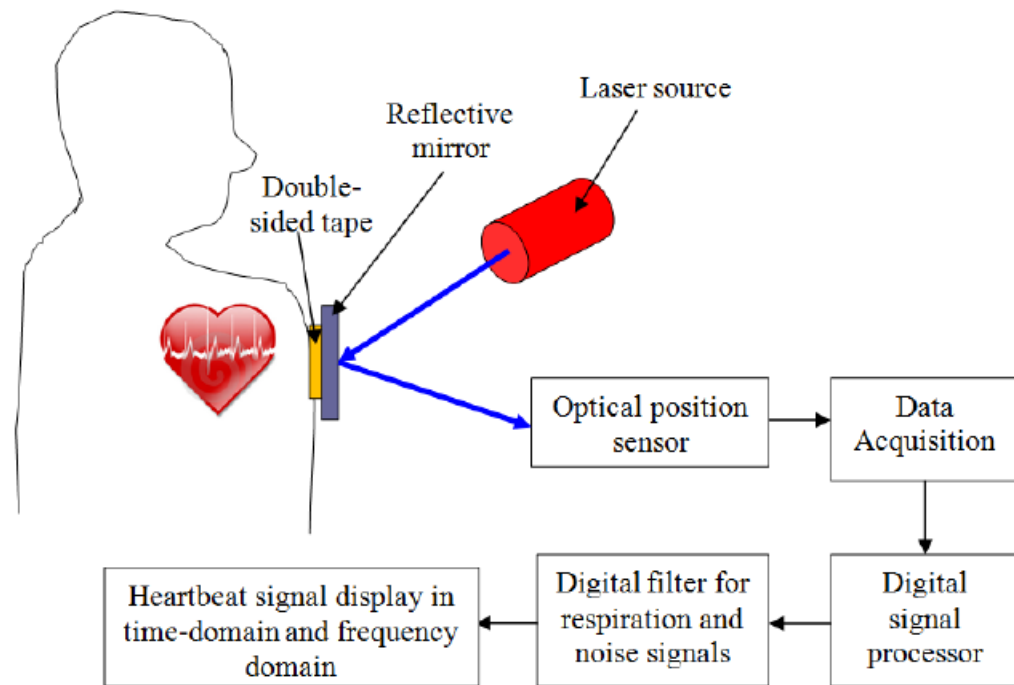

Figure 1 System Design of Laser-based stethoscope [1]

Figure 1 shows the testing setup of prototype of the system on the dummy human body in Medical School at UMD. The reflective mirror is attached to the chest of the dummy. The Aerotech 110SF 5.0mW red laser is used as the laser source. The laser beam is incident on the mirror attached to the dummy body chest. The beam reflected from the mirror is directed to the linear position sensor manufactured by Edmund Optics. The linear position sensor measures the movement of the reflected spot in the time-domain. Such movement is correlated to the vibration of the chest skin with the heart sound. Several heart sound patterns including the normal and abnormal from the database of the dummy body system are picked to demonstrate the measurement results. For each heart

pattern, the testing results from the laser prototype system are compared with the simultaneous results from PCG and good agreement is achieved, which successfully demonstrates the conceptual design of heartbeat detection based on the vibration of chest skin.

However, for the ease of practical application, this heartbeat detection system should be made more compact and portable. The main difficulty for the laser-based system lies in that the laser and optical sensor, which are the two key components are both bulky in order for the best detection resolution. Thus, we focus our current effort on developing a more brisk sensing system for the human chest vibration amplitude with the heartbeat, from which the heartbeat signals can be extracted.



Figure 2 Testing of the prototype of the system on the dummy human body [1]

## 1.2 Motivation

Based on the verified concept in our previous laser-based research [1], in the ongoing research we aim to overcome the difficulty of integration from the laser-based heartbeat detection system, and develop a heartbeat detection system based on pressure sensing. The pressure sensing system includes a skin-like sensor array, the voltage provider for the sensing array and the data acquisition (DAQ) unit. The whole system will be developed through the collaboration between our research group and the research group led by Prof. Debao Zhou in MIE at UMD. The task of our group focuses on the voltage supply circuit design for the sensing array to supply a sequence of voltage potentials each row of the array. The MIE group is working on the development of the sensing array and the DAQ unit.

### **1.3 Scope**

The integrated circuit (IC) we developed should have single input and multiple outputs. The voltage on each output lead is set at 5V, which is required by the sensing array. The sensing array is designed to be 3in by 3in, with 16×16 sensing sensors in each square inch. Thus, the circuit should possess 48 output leads in total. Due to the size limit, one circuit chip could only accommodate several output leads and the 48 leads could be accommodated by several identical chips. The prototype of the designed circuit will be implemented on the breadboard for testing purpose. Finally, the circuit will be built on the 3mm by 3mm semiconductor chip using the microelectronic technology.

The thesis is arranged as follows: Chapter 2 covers the several circuit design schemes; Chapter 3 describes the voltage supply circuit design; we present the testing

results of the designed circuit in Chapter 4; finally, we conclude and offer the future recommendation of this research in Chapter 5.

## **Chapter 2 Theoretical Background on Circuit Design**

In this chapter, we will present an overview of the heartbeat measurement methods and the key methodology used in the circuit design.

### **2.1 How to measure heartbeats?**

Pulse, which is also another name for a heartbeat is generally measured to find if the heart is working properly. Changes in heartbeat rhythm can be a good indication of an arising heart problem. As the heart beats, a pulse can be felt in some specific parts of our body like the wrist or the neck. Pulse rate is more when we exercise, have fever or are under stress.

Pulse rate is measured to check:

- 1) If the heart is working properly and supplying enough blood to the body
- 2) To help find the cause of different diseases like palpitations, dizziness etc.
- 3) Check general health and physical well-being of an individual [9]

#### **2.1.1 Manual method (Taking Pulse)**

The pulse can be measured at some specific parts of our body like the wrist or the neck. It is generally done manually, by placing our hand at the position and count the



number of pulses in a particular time period and multiplying it by a specific number to get the beats per minute (bpm) value. The general process is shown in the figure below.



Figure 3 (a) Taking pulse at wrist (b) Taking pulse at neck

### 2.1.2 Using stethoscope

The widespread use of stethoscope in the medical industry has made the stethoscope an icon in the medical industry.

Working of Stethoscope:

When the heart beats, lungs get filled up with air. There are sound vibrations coming from the body. These sounds are picked up and amplified by the diaphragm. The sound passes through the tube, which is passed into the doctor's earpieces. The doctor can analyze by hearing the 'lub-dub' sound made by the heart. Electrical stethoscopes have a microphone attached to pick up and amplify the sound. Since electrical

stethoscopes lose or distort parts of the sound, acoustic stethoscopes are generally preferred over electrical stethoscopes [11].

At a time when new diagnostic technologies threaten to render the stethoscope obsolete, doctors are shown to want to retain the instrument as a symbol of the skill and knowledge they possess, but which they believe to be increasingly devalued and undermined in modern medicine [10].



Figure 4 Heartbeat Testing using Stethoscope

### 2.1.3 Monitor method

An ECG is used to monitor the heart. When the heart beats, each beat is triggered by an electrical impulse generated by some special cells in the upper right chamber of heart. Electrocardiogram (ECG/EKG) records these electrical signals as they travel through the heart. As shown in figure, electrodes are taped to the chest to record the chest's electrical signals. The signals can be viewed on attached computer or a printer.

ECG can be used by doctor to look for patterns among heartbeats and rhythms to diagnose various heart problems. It is a non-invasive and painless procedure. [12]



Figure 5 ECG [12]

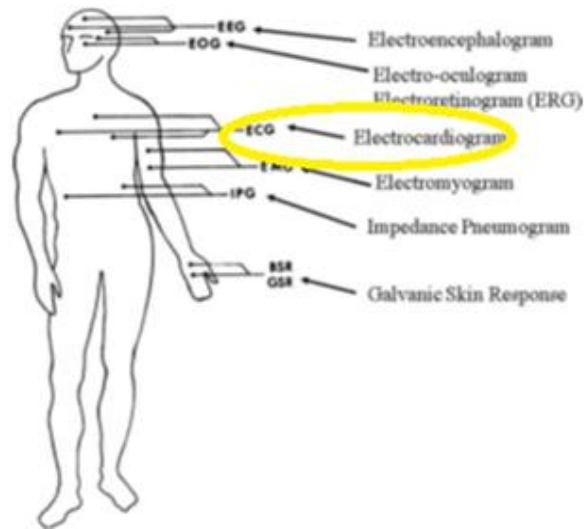

Figure 6 Different parts of body along with the signals they give out

Heart disease is a term that can define many different conditions. All these conditions have some effect on the heart or the blood vessels that supply the heart. Because heart is a part of the human circulatory system, heart disease will cause malfunction of other parts in the system. Hence, it is necessary to diagnose the indications given by the different heartbeat sound. In the process of auscultation, medical professionals use a stethoscope to examine the condition of heart and to gather important audio data

Though there are so many techniques already available for heartbeat detection, new techniques are always being researched, which would give better results. We are using an array of sensors for this project to detect the heartbeats. The array of sensors has to be given supply voltage in a specific way for them to perform satisfactorily. Thus, the task was to design a circuit that would give a series of pulses as an input to the sensors. In this chapter we will be going through a circuit which gives outputs similar to our circuit's requirements.

## **2.2 Sequence of pulse generation**

In digital circuit design, a shift register is a cascade of flip-flops, where the output of the first flip-flop is fed as the input to the next flip-flop in series. After every clock cycle trigger, the data gets shifted from one flip-flop to the next, thus forming a sequence.

Shift registers can have both serial as well as parallel inputs and outputs. There are 4 different types of shift registers based on the way the input is fed and the output is taken out:

- 1) SISO: Serial-in, serial-out shift register
- 2) SIPO: Serial-in, parallel-out shift register
- 3) PISO: Parallel-in, serial-out shift register
- 4) PIPO: Parallel-in, parallel-out shift register

Out of these, the results of the SIPO configuration are most similar to the results expected from the circuit to be designed. It is called a shift register.

### 2.2.1 SIPO

This format allows conversion from serial to parallel format. Data is input serially and taken out in parallel. It shifts data into internal storage elements (D flip-flops) and shifts data out at the output pins, making all the internal stages available as outputs. If four data bits are shifted in by four clock cycles via a single wire at the data in input terminal, then at the end of four clock cycles, the data becomes available simultaneously at the four output terminals  $Q_A$ ,  $Q_B$ ,  $Q_C$  and  $Q_D$ .

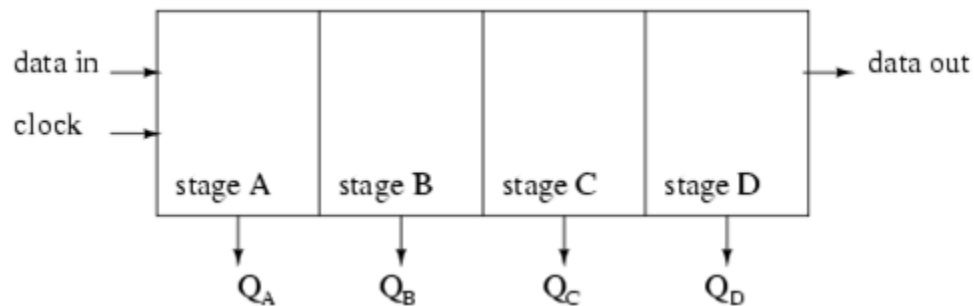

Figure 7 Four stage SIPO register

The actual circuit diagram of a shift register is shown below. The requirements of the circuit were similar to this circuit of shift register. But it did not require output to be fed in serially because if that is the case then we will need the sequence to be dependent on  $n$ , the number of flip-flops used. But since number of flip-flops has to be variable, we cannot use the same circuit. Also, it is much easier if we can give a constant supply

voltage to run the circuit rather than giving pulses, because it will be easier with respect to timing issues.

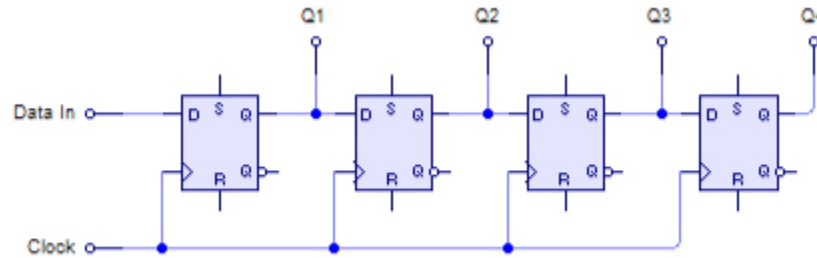

Figure 8 Circuit diagram of SIPO register [18]

The main component used in the circuit is the delay flip-flop or the D flip-flop whose working needs to be studied to get the clear working of the shift register. The following section gives a brief overview of the D flip-flop working.

### 2.2.2 D Flip-Flop

A D flip-flop is a flip-flop which has only one input called the D input. Truth table of a D flip-flop is:

| Input $D_n$ | Output $Q_{n+1}$ |
|-------------|------------------|
| 0           | 0                |
| 1           | 1                |

Thus, basically for a D flip-flop the output follows the input. Transfer of data from the input to the output is delayed till the end of the clock cycle. Hence, it is called

delay (D) flip-flop. The D-type flip-flop is either used as a delay device or as a latch to store 1 bit of binary information.

In addition to this, there are two more stable states for the flip-flop called the set (set to 1) and reset (set to 0). Both the set and reset pins are active low so that they should be made high if we do not want the flip-flop to be stable in one of those states [15].



## **Chapter 3 Power Supply Circuit Design for the Sensor System**

In this chapter, we demonstrate the circuit design methodology, the major function of components in the circuit, the software support for designing the circuit and the layout of the circuit.

### **3.1 Expected function of the circuit**

The sensor under study is a skin-like sensor to measure the contact force caused by the chest skin vibration. The chest skin vibration is directly related to the heartbeat. The sensor contains a matrix form of sensors (16×16). The contact force is measured by the piezoresistive layer in the skin-like sensor. There will be data of contract force read from each sensor, which forms data grid. This could help us identify the spot on the chest skin with the maximum vibration amplitude. That would be the spot which gives the most accurate results for the heart sound. Based on requirement of the sensor under study, to power the sensor, we need to provide 5Vpp voltage pulses in sequence to multiple contact terminals of the sensor. Each pulse should keep constant 5V voltage for at least 0.5 second in order for enough time of sensor measurement. Below we list the detailed design criteria of the circuit based on the sensor working requirement:

- 1) The circuit should provide 5Vpp output pulses in a sequence.
- 2) There should be 8 outputs in each circuit, which is based on the array of the sensors.

- 3) A number of such circuits should be able to be connected in series so that the number of sensors to be used can remain flexible.
- 4) It should operate at frequencies as low as 2Hz.

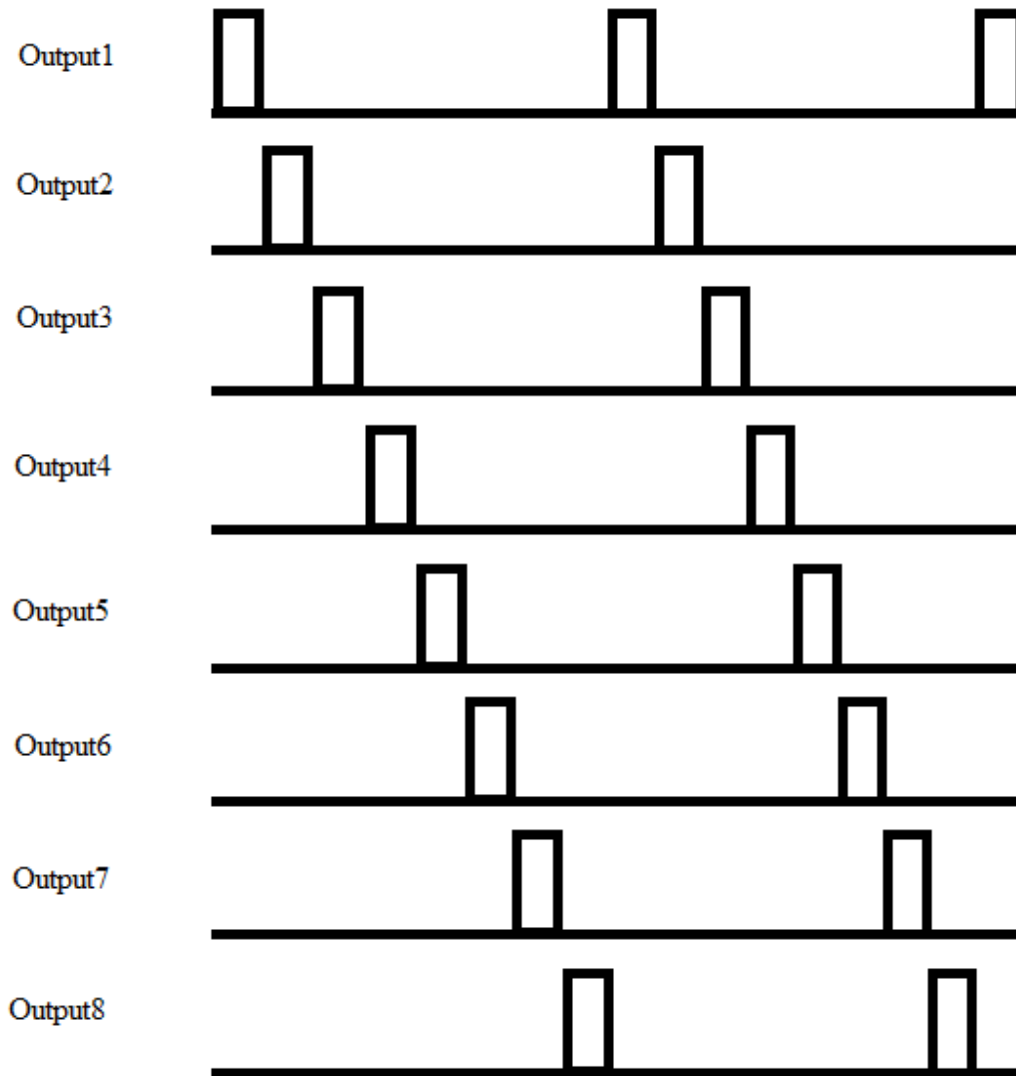

Figure 9 Required outputs

Figure 9 shows the desired output pulses from the circuit. It should give a 5Vpp pulse at each output. Each circuit is to be designed so that it will give 8 such outputs. A number of such circuits when connected in series should still follow the sequence. Thus, first goal is to design a circuit which will give outputs as shown in figure above. This is a comparatively easy task because a number of circuits could give this result. The real challenge is to connect a number of such circuits in series such that the second circuit would start only after the first one stops and the sequence will continue for all the circuits in series and at the end the first circuit will start back again.

### **3.2 Components used in the circuit**

In this supply circuit, we used a number of digital components like flip-flops, diodes, resistors and capacitors.

#### **3.2.1 D Flip-Flop,**

As already discussed in section 2.2.2 earlier, a D flip-flop output follows the input. The flip-flop used for the circuit is the SN74LS74A dual edge-triggered flip-flop. It is a Schottky TTL circuit used to produce high speed D flip-flops. Each D flip-flop has individual set and reset inputs and also Q and complementary Q as outputs. Signal at input D of the flip-flop is transferred to output Q on the positive-edge of the clock since it is a positive edge-triggered flip-flop. The output does not change when the clock input is either HIGH or LOW. It changes only when the clock input goes from low to high, as it is

a positive edge triggered flip-flop. When the clock input is at either the HIGH or the LOW level, the D input signal has no effect.

## SN74LS74A

### LOGIC DIAGRAM (Each Flip-Flop)

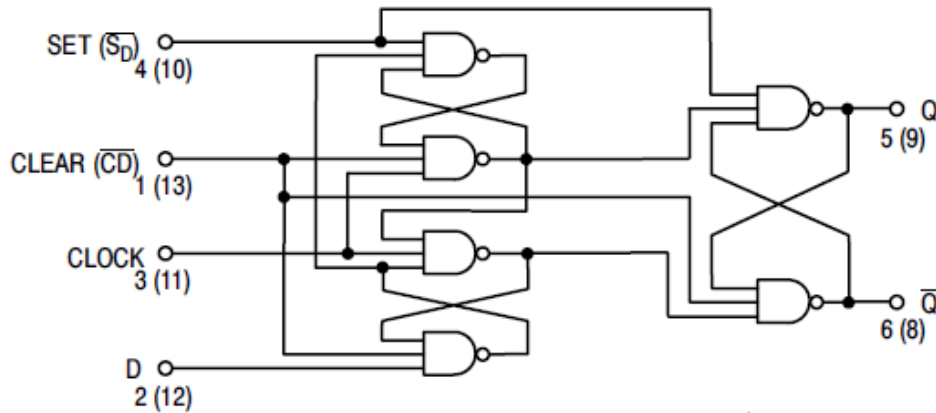

Figure 10 Logic Diagram of D Flip-Flop

### 3.2.2 Diode

A diode is basically a switch which allows current to flow in only one direction and blocks the flow of current in the opposite direction. They are nothing but one-way valves that are used in many circuits. Though there are different types of diodes, the main functionality of all the diodes remains the same.

The 1N4148 is a fast-switching diode fabricated in planar technology and encapsulated in hermetically sealed leaded glass [13]. As stated above, the main reason why the diode has been used in the circuit is because it allows current to flow in only one direction. Thus, when the Q output goes high, the Qbar output goes low, making the

diode forward-biased. Thus the first output of the circuit, which is the input of the first flip-flop remains low because the low Qbar output gets connected to it [14].

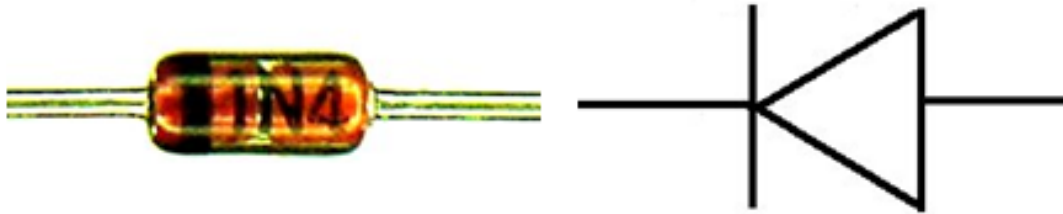

Figure 11 Diode 1N4148 diagram and symbol

### 3.2.3 Capacitor

A capacitor is used to store the electric charge. It is capable of storing electrons but not generating them. A capacitor has two plates, separated by a dielectric material. The dielectric used depends on the application. The capacitance of a capacitor is the ratio of the charge stored by the capacitor and the voltage applied across the capacitor plates. Also, the capacitance of the capacitor is defined as  $C=\epsilon A/d$ ,

Where  $\epsilon$ =permittivity of the dielectric,

A=area of plates,

d=width of the dielectric or distance between plated. [16]

The capacitor used in the circuit is 0.1uF capacitor. It is used in the reset circuitry for the flip-flops. It is required that all the flip-flops should start at the same point when

the power is turned on. The resistor-capacitor circuit is thus used so that all the flip-flops will start at the same initial value.



Figure 12 Capacitor diagram and symbol

#### 3.2.4 Resistor

A resistor is nothing but a current-limiter. They are considered as the most important part of an electronic circuit. As we already know, there are two kinds of elements, the conductors and the insulators. Conductors allow the flow of electrons while insulators do not allow electrons to flow. The amount of electricity that we want to pass depends on the resistor value used. For example, if a large voltage is applied across a conductor, large current will flow through it and a large voltage will be developed across it. But, if a resistor is used in series with the conductor, both current through the conductor and the voltage developed across the conductor can be controlled.

According to Ohm's law, the voltage developed across a resistor is directly proportional to the current flowing through it. This constant of proportionality is called the resistance.

Thus,  $R$  (in ohms) =  $V$  (in volts)/ $I$  (in amperes)

Thus, resistance can be defined as the voltage required making a current of 1A to flow through the circuit. [17]

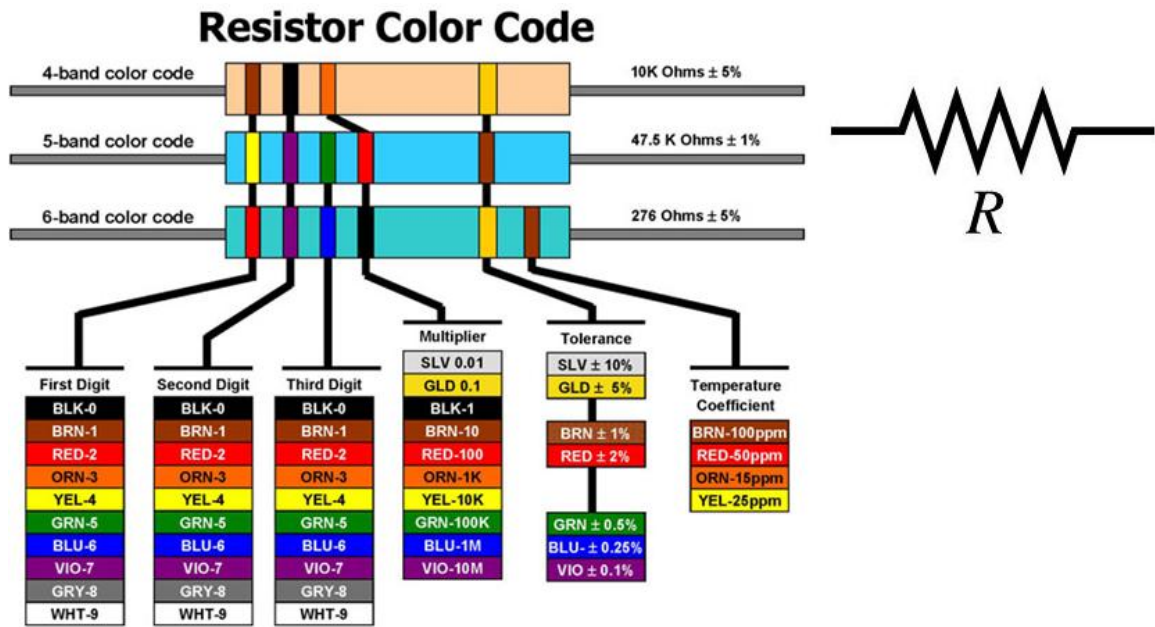

Figure 13 Resistor diagram showing color code and symbol

### 3.2.5 Breadboard

A breadboard, also called as a protoboard is a construction board for prototyping of electronic circuits. Hence, they are reusable. They can be used to prototype small and

big, analog and digital circuits. Really complex circuits which contain a millions of transistors are impossible to connect with breadboards, because it is hard to have so many physical connections. Also, they are so complex that it is also very difficult to debug these circuits on a breadboard. Hence, nowadays simulation softwares are used where we can have the first prototype on the computer and after it is tested on the computer, we can build printed circuit boards for the circuits.

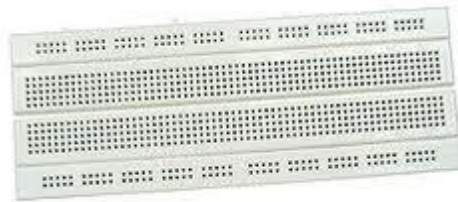

Figure 14 Breadboard

### 3.3 Circuit design methodology

The main aim of the circuit is to give a series of pulses. The operation is similar to the operation of ring counter mentioned in the earlier chapter of thesis. So, D flip-flops are used in the circuit. As it is required that one pulse should stop before the start of the next circuit, it is necessary to use some kind of diodes so that the pulse will remain ON only for one clock cycle and will go to zero at the next cycle. Since it is important to reset the flip-flops so that they all start at the same initial point, the RC circuit was used.

The amplitude of the pulses is required to be 5Vpp, so we use the TTL 74LS74N. It is also suitable for the low frequency of 2Hz. Normally available 1N4148 diodes are



used to make sure that the pulse goes to zero after the clock cycle. Standard values of resistor and capacitors equaling  $1\text{k}\Omega$  and  $100\text{nF}$  are used respectively.

### **3.4 Circuit design with Multisim software**

Multisim is an industry standard and best-in-class SPICE simulation environment. It helps us to simulate the circuit so that a number of prototype iterations can be saved and better PCB boards can be developed. Multisim is used by both students and professionals, to save prototype iterations and develop better boards in fields such as Analog Electronics, Power Electronics and Renewable Energy [4].

The first step in designing the circuit is to use Multisim to simulate the working of the circuit to find whether the circuit is working properly. Different circuits were tried out using Multisim.

Figure 15 shows the first circuit tried using Multisim. The first three flip-flops indicated in the figure act as frequency dividers and finally at the end of the third flip-flop we get a frequency that is 8 times the original frequency. ANDing of the three outputs from the three flip-flops would give the pulse which will go through each D flip-flop after the AND gate and thus constitute the outputs. This was done so that the same clock signal could be used to control all the flip-flops simultaneously, as use of two clock signals would have caused synchronization problems. Thus, we could get the 8 outputs from the circuit, where the first output would be the output of the AND gate and the next

7 outputs would be the outputs of the next 7 flip-flops connected in series and clocked by the same clock signal.

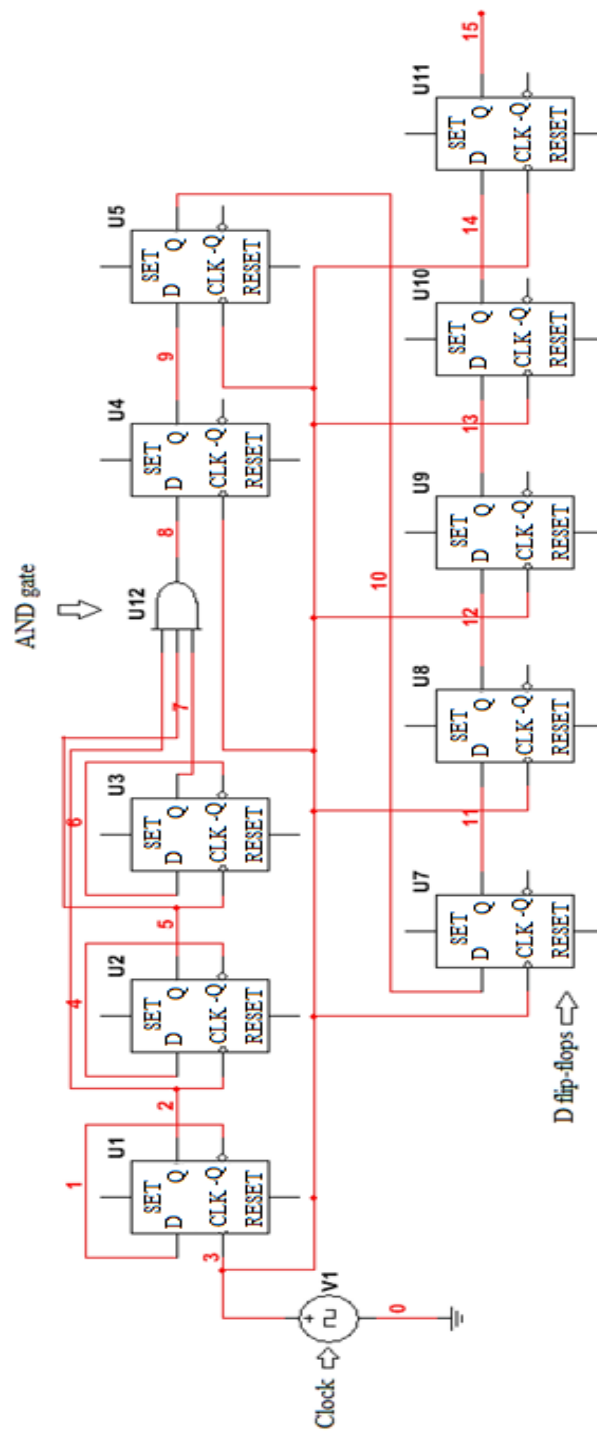

Figure 15 First circuit designed using Multisim

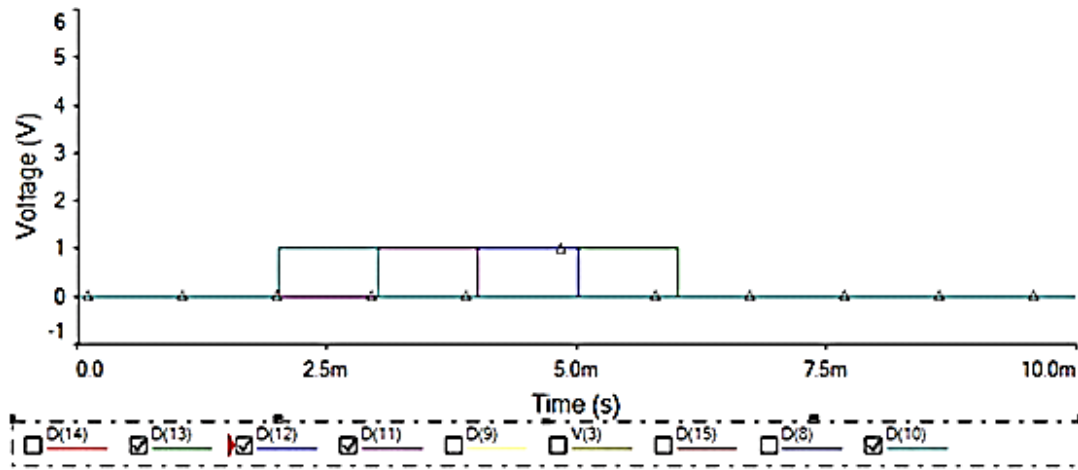

Figure 16 Multisim results showing voltage versus time waveforms of the circuit.

Figure 16 shows that we get the sequence of pulses from this circuit. But, the circuit designed is good for just one circuit. If more than one circuit are connected in series, the sequence is not followed properly. Also, a number of extra components like JK flip-flops are needed to be used for the connection circuitry between the circuits. This makes the circuit much more bulky than it actually needed to be. Though this circuit worked properly on Multisim, it gave many problems in real-time, most of which are timing issues. Moreover, testing a circuit of this magnitude on the breadboard is difficult. Hence, it is needed to design a better circuit which could be easier to test on a breadboard and used lesser components.

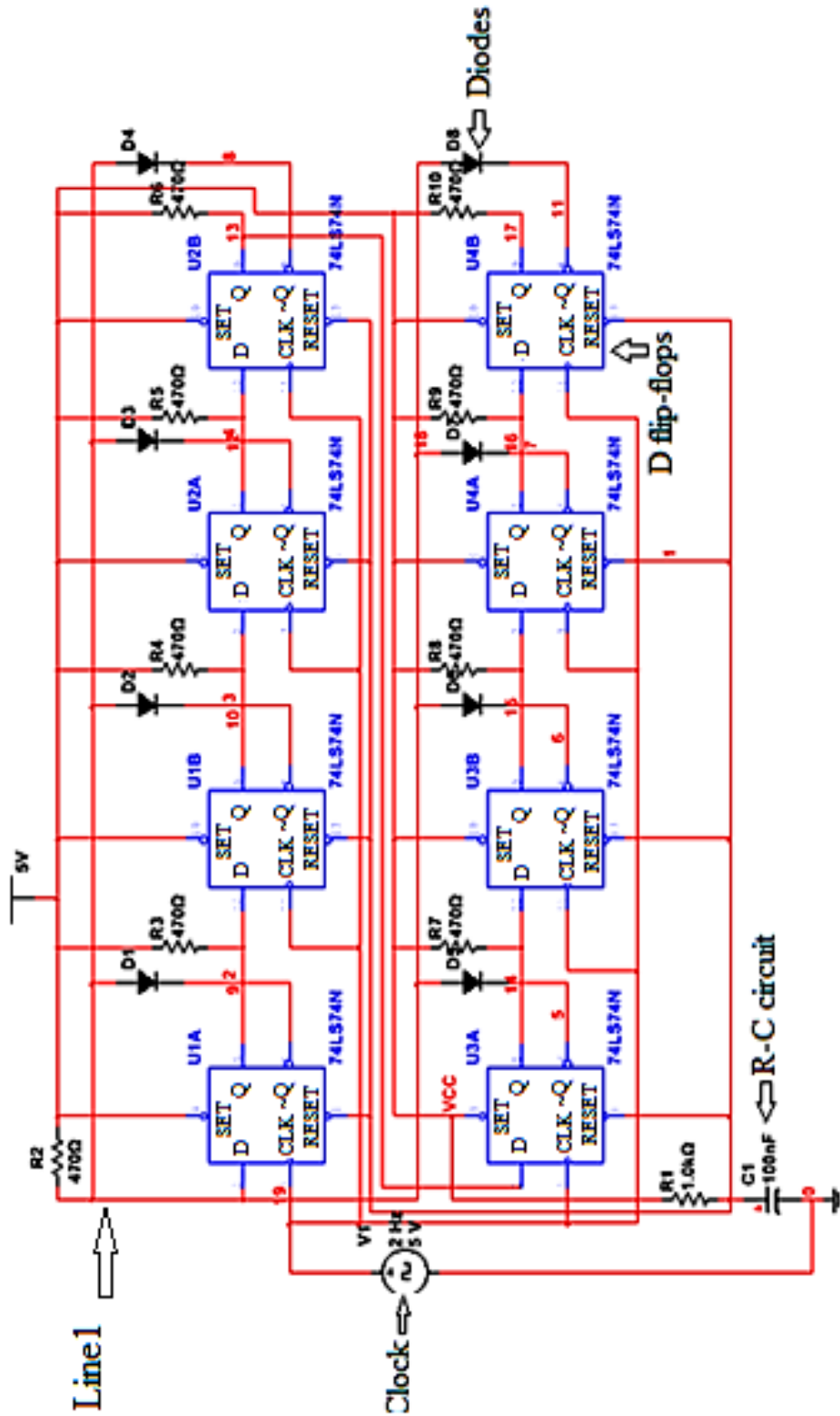

Figure 17 Second (Final) circuit using Multisim

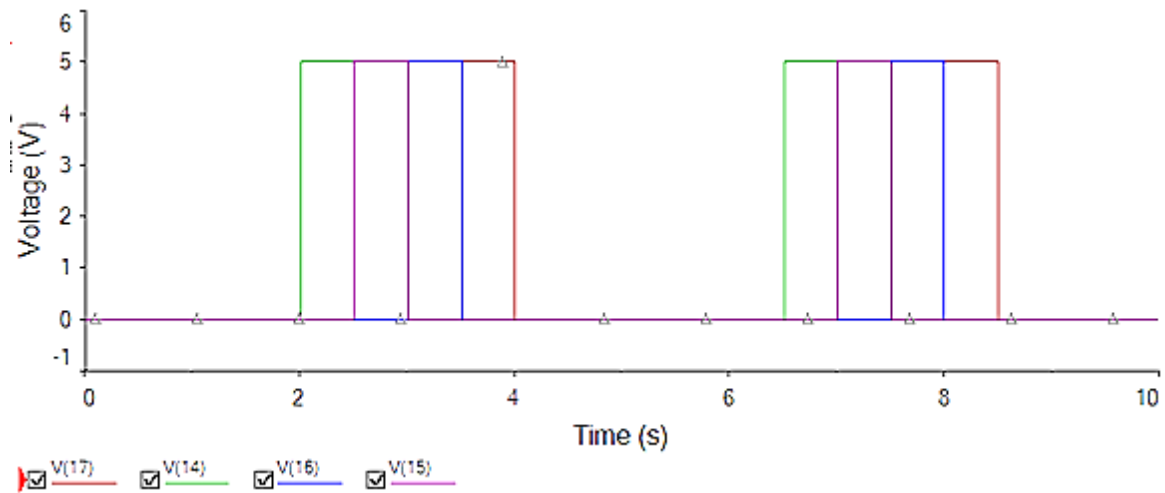

Figure 18 Multisim results showing voltage versus time waveforms of the circuit

Figure 17 shows the second and final circuit tried using Multisim. With this logic, we can add as many outputs as we want. The input to the first flip-flop (output1) is connected to the power supply through a pull-up resistor (Line1). So, initially it goes high because it is connected to the power supply. After the first clock cycle, output of the first flip-flop (output2) goes high. The negative of this output is connected to Line1, but through a diode 1N4148. When the output of the first flip-flop goes high, the inverted output goes low, so that the diode is forward-biased and it starts conducting. This makes the Line1 low, which causes the first output (which is the input to the first flip-flop) to go low. With every clock cycle, this pulse proceeds through the entire circuit and there is a pulse at each output in a sequence. The corresponding inverted output goes low every time, making the diodes forward-biased one at a time, making Line1 low, not allowing the first output (which is input to the first flip-flop) to go high unless the pulse is supposed to go back. When the last output goes from high to low, the last inverted output

goes from low to high, making the diode reverse-biased. Hence, now the first output (which is the input to the first flip-flop) goes high again and the sequence continues. We can connect how much ever outputs we want in a series following this principle.

Figure 18 shows that the required sequence of pulses is properly maintained. Also, the connection between the circuits is not an issue because the same logic can be extended to the number of outputs we require.

### **3.5 Layout of circuit for PCB fabrication by EAGLE software**

EAGLE stands for Easily Applicable Graphical Layout Editor is a software developed by CadSoft Computer and is a flexible and expandable Electronic Design Automation (EDA) application with schematic capture editor, PCB layout editor and auto-router tools.

#### **3.5.1 Schematic Capture**

The main use of the Schematic Capture is to draw the circuit diagrams.

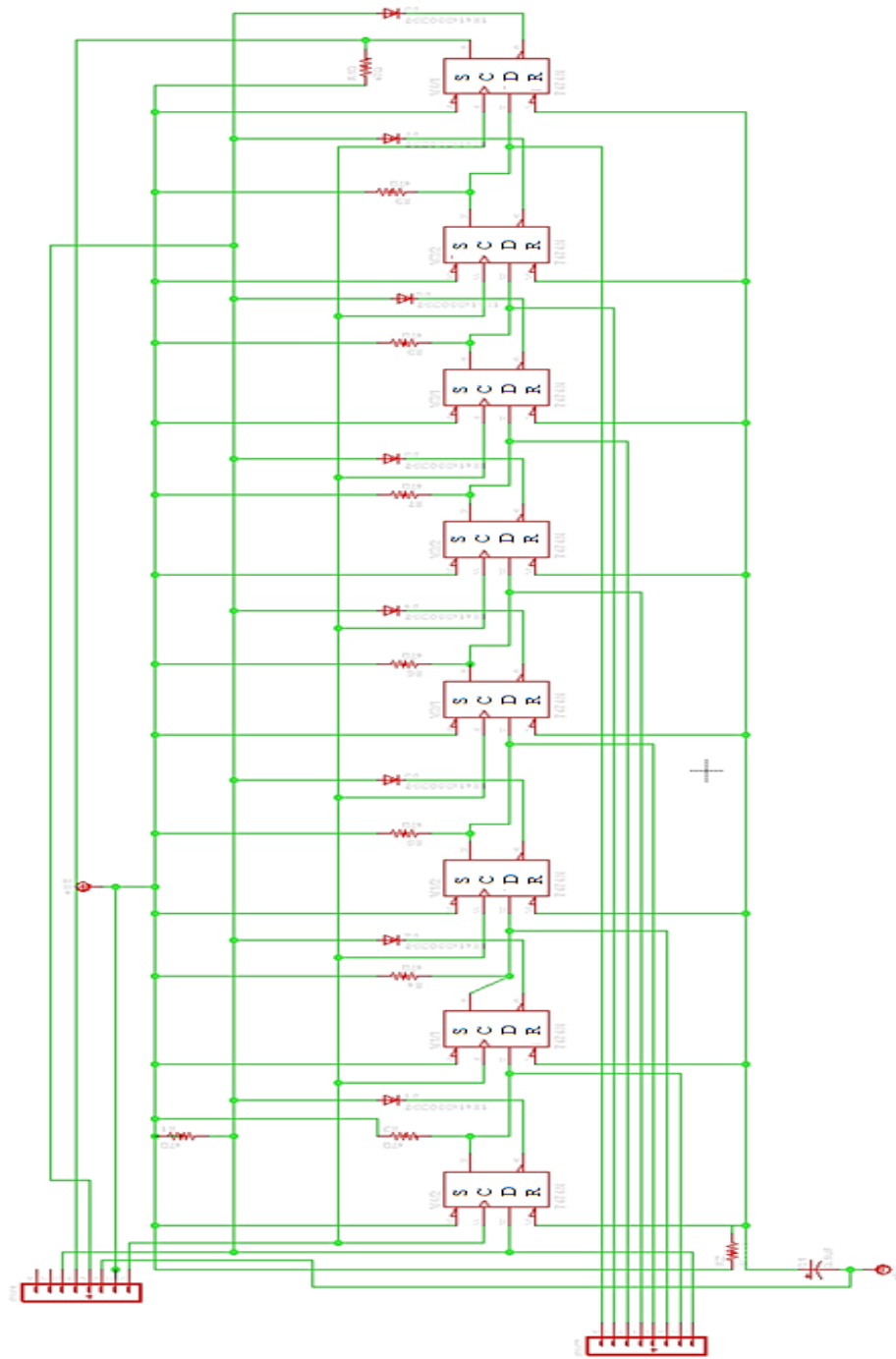

Figure 19 Circuit Schematic in EAGLE



### 3.5.2 Layout Editor

The layout has back-annotation capacity with the circuit so that components in the schematic readily appear in the layout. The components can be connected according to the traces in the circuit schematic. There are two options available: manual-route and auto-route. With auto-route, most of the connections on the PCB board get connected as they are connected in the schematic. But not all the connections can be made using auto-route. The connections which cannot be achieved automatically by the auto-router have to be connected manually. Specifically, if we want a really small and compact board which is really space-efficient, then manual routing is preferred. For all other purposes, auto-routing is good enough.

EAGLE software can be used to create Gerber files which are used by PCB manufacturing companies.

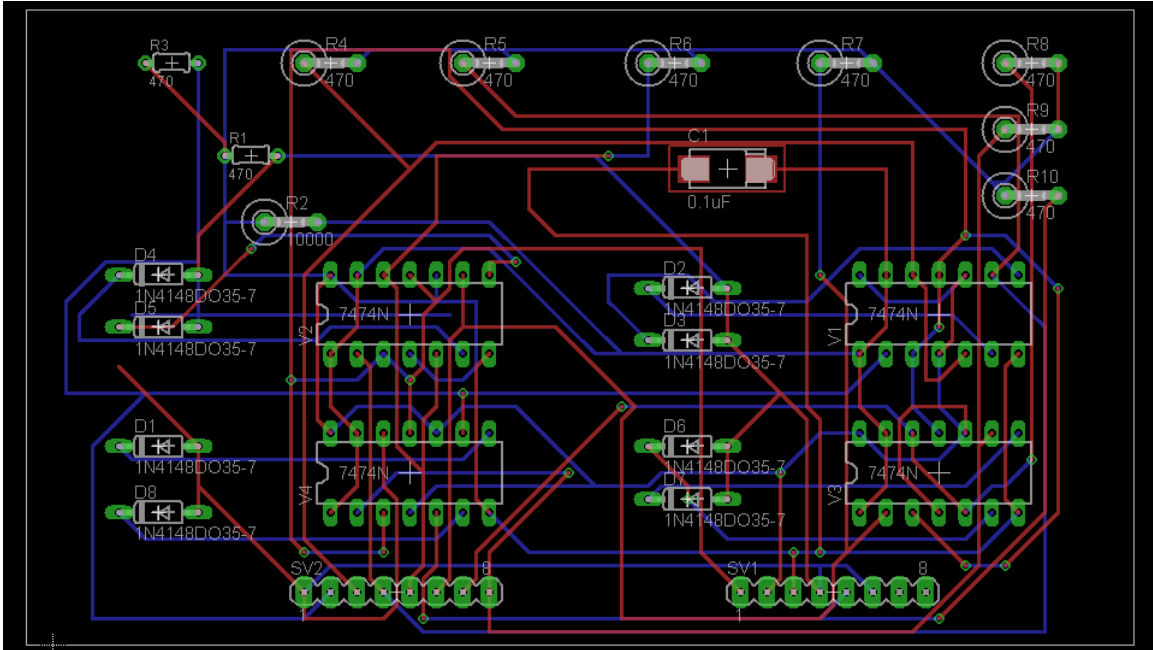

Figure 20 PCB Layout in EAGLE

### 3.6 Gerber Files Generated

Inside many electronic devices, there is a printed circuit board (PCB) on which components are connected. These PCBs are designed using some kind of computer-aided design (CAD). We need to transfer the CAD to a computer-aided manufacturing (CAM) system. Gerber file format is widely used to do the same. Thus, the gerber file format is the printed circuit board (PCB) industry's software to describe the board image's copper layers, solder mask, legend, drill holes etc.

Gerber is a standard file format used to convey information to the PCB manufacturing companies. In general, Gerber files are analogous to the PDF files. Gerber files, being the core component of the PCB manufacturing and supply chain, are required to be created if we need to manufacture a PCB.

For EAGLE software following are the extensions of the different Gerber files.

| File Extension | Description       |
|----------------|-------------------|
| .cmp           | Top Copper        |
| .sol           | Bottom Copper     |
| .stc           | Top Soldermask    |
| .sts           | Bottom Soldermask |
| .plc           | Top Silkscreen    |
| .pls           | Bottom Silkscreen |
| .ncd           | NC Drill          |

### 3.6.1 Top Copper Layer

The .cmp file is an image of the copper conductor for the top side of the circuit board. As there are two sides in a 2 layered PCB, some connections run through the top side while others run through the bottom side of the PCB. The .cmp file in Figure 21 shows how the copper conductors on the top side of the PCB board will look like.

The .cmp files are generated using the top, pads and vias.

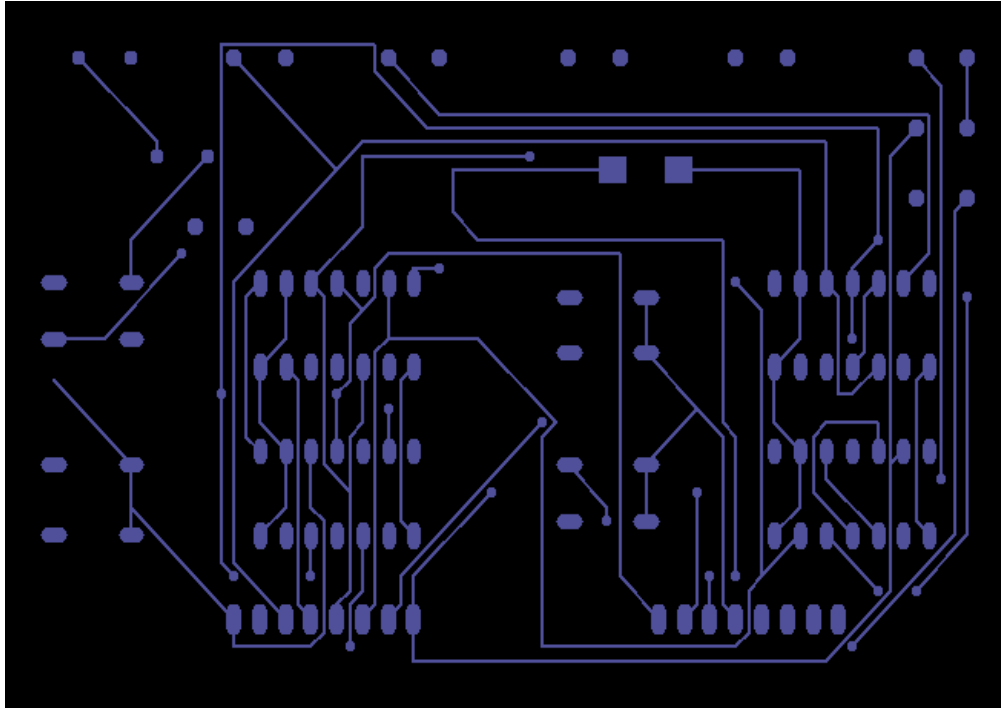

Figure 21 .cmp file

### 3.6.2 Bottom Copper Layer

The .sol file is an image of the copper conductor for the bottom side of the circuit board. As already stated earlier, there are two sides in a 2 layered PCB with some connections running through the top side while others running through the bottom side of the PCB. The .sol file in Figure 22 shows how the copper conductors on the bottom side of the PCB board will look like.

The .sol files are created using the bottom, pads and vias.

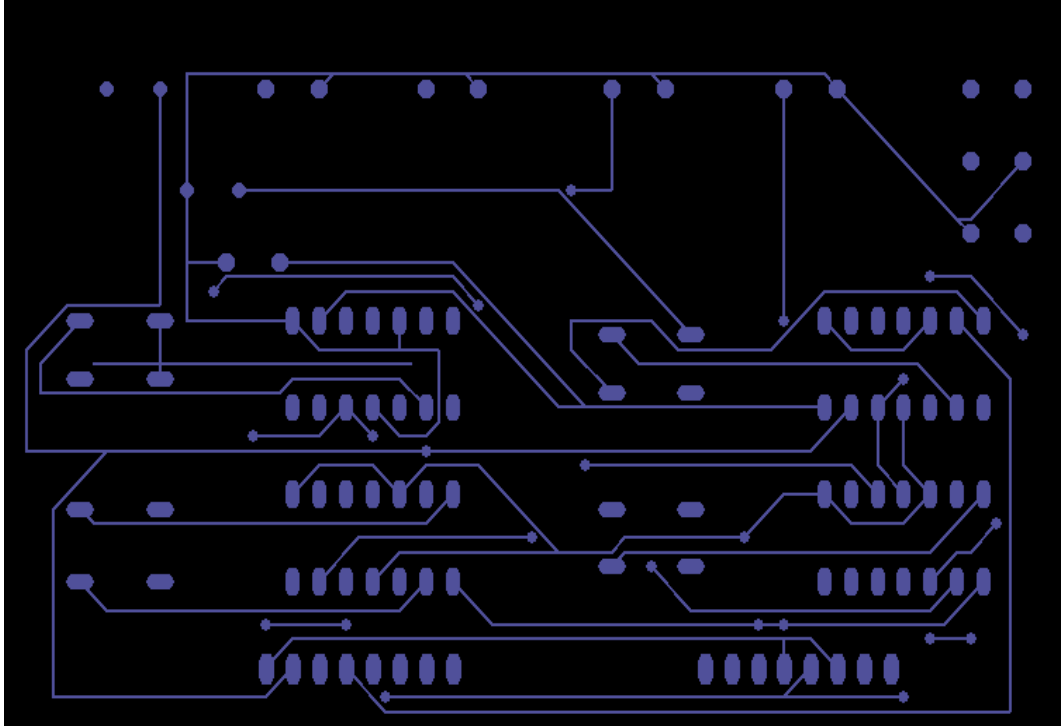

Figure 22 .sol file

### 3.6.3 Top Solder Mask

A solder mask is usually applied to the copper traces of a PCB for protection against oxidation and to prevent the formation of silver bridges between closely spaced solder pads. As there is solder on both the sides of the board, solder mask is also used on both sides of the PCB.

The .stc file shown in Figure 23 is an image of where solder mask is to be applied on the top layer.

The .stc files are created using tStop.

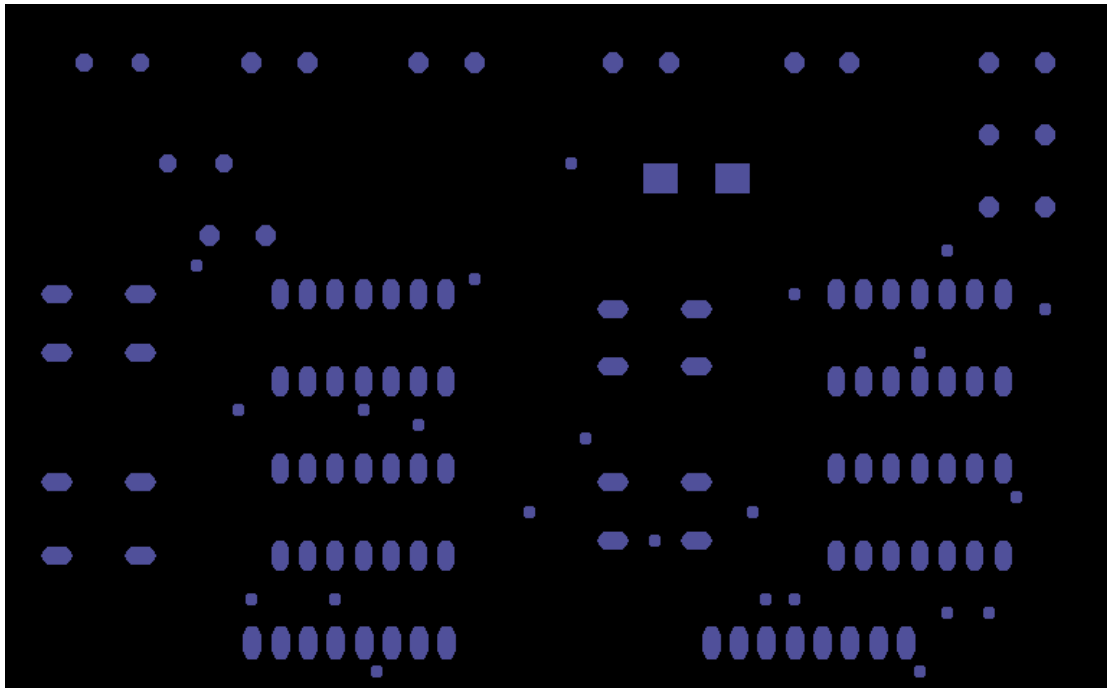

Figure 23 .stc file

### 3.6.4 Bottom Solder Mask

As already mentioned in the earlier subsection, there is solder mask on both the sides of the PCB. The .sts file shown in Figure 24 is an image of where solder mask is to be applied on the bottom layer.

The .sts files are created using bStop.

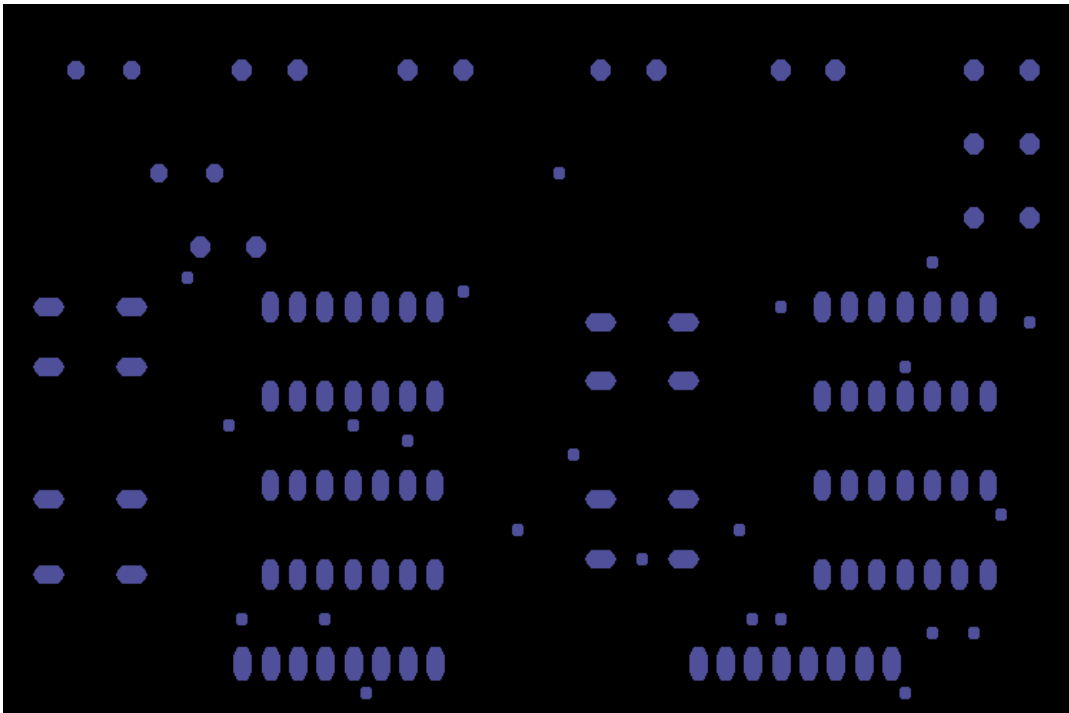

Figure 24 .sts file

### 3.6.5 Top Silkscreen Layer

Text and picture labels may be printed on the surface of a PCB using screen printing. Screen print is also known as silk screen. Thus, the .plc file shown in Figure 25 is an image of where silkscreen is to be applied on the top layer.

The .plc files are created using dimension, tPlace and tNames.

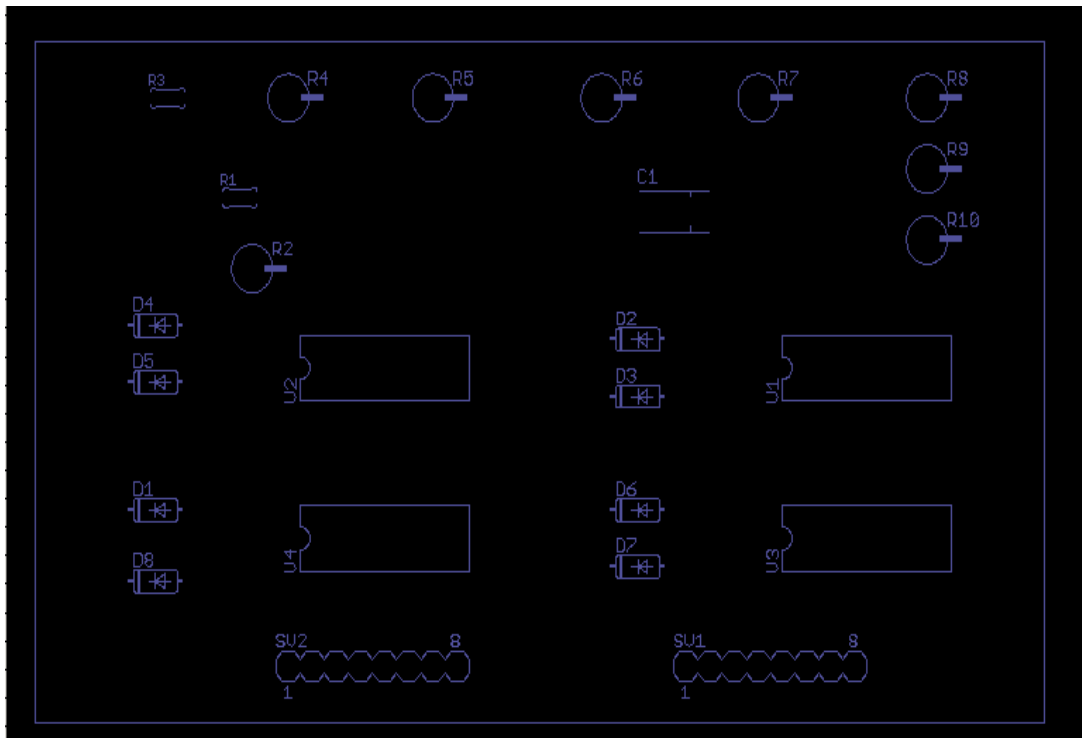

Figure 25 .plc file



### 3.6.6 Drill File

To assemble the components on the PCB, it is required that we drill holes through the PCB so that the components can go through. The .ncd file shown in Figure 26 is an image showing the locations of the drilled holes and descriptions of the properties of the holes.

The .ncd files are created using drills and holes.



Figure 26 .ncd file

## **Chapter 4 Testing of circuit**

The breadboard testing of the circuit was done in MWAH lab 393 using the equipments available in the lab. The purpose of testing was to make sure that the circuit is performing according to the requirements. The circuit was tested with respect to amplitude of each pulse, the width of each pulse and the sequence of pulses. Those were the three basic requirements of the circuit, which were ensured from the testing.

### **4.1 Testing equipments used**

#### **4.1.1 Function generator**

Function generator is used to provide the clock signal to the circuit. The function generator used had a range of 20 MHz, so that the maximum clock signal that could be given was 20MHz. We used a clock signal ranging from 2Hz-20 kHz to test the circuit. This range of frequency testing was chosen based on the fact that the human heart beats approximately 72 times per minute, which gives a frequency of about 1.2 Hz. Hence it was necessary to make sure that the circuit worked with a frequency as low as 2Hz. The higher end of 20 kHz was chosen to make sure that the circuit will work even at 20 kHz if required in future.



Figure 27 Function Generator

#### 4.1.2 Power supply

The power supply was used to give power to all the flip-flop IC 74LS74N chips. It was also used to create the pulse that will move through the circuit giving the required results. The power supplies in the lab were capable of giving a maximum signal voltage of 6V which was enough for our use, because the circuit could work on a supply of 5V.

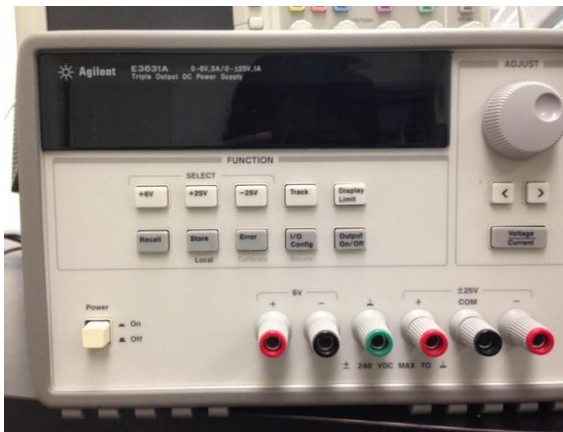

Figure 28 Power Supply

#### 4.1.3 Digital Storage Oscilloscope (DSO)

It was used to view the final signal outputs in real-time. The DSO used in the lab had 4 channels, so that 4 signals could be viewed on the DSO at a time. Viewing 4 signals at a time was sufficient to check the sequence of the circuit.



Figure 29 DSO

#### **4.2 Breadboard circuit**

Here, for testing purposes, we used 3 individual circuits explained in the earlier section. The 3 circuits can be easily found demarcated shown in the Figure 30. The different components in the circuit of Figure 17 are connected on the breadboard through connecting wires.

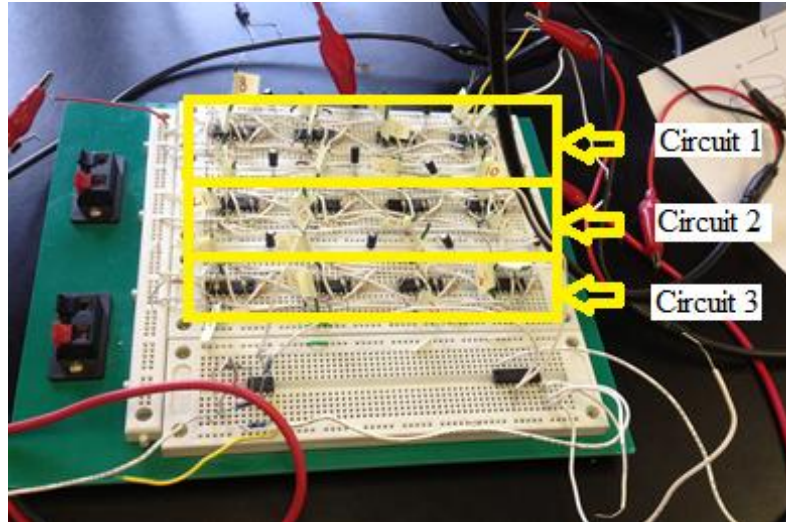

Figure 30 Breadboard circuit

### 4.3 Testing Setup

The Figure 31 shows the testing setup used in the lab. It shows the use of 2 function generators, a power supply and a DSO to test the circuit as mentioned in the sections above. Probes are used to connect the different testing equipments together.

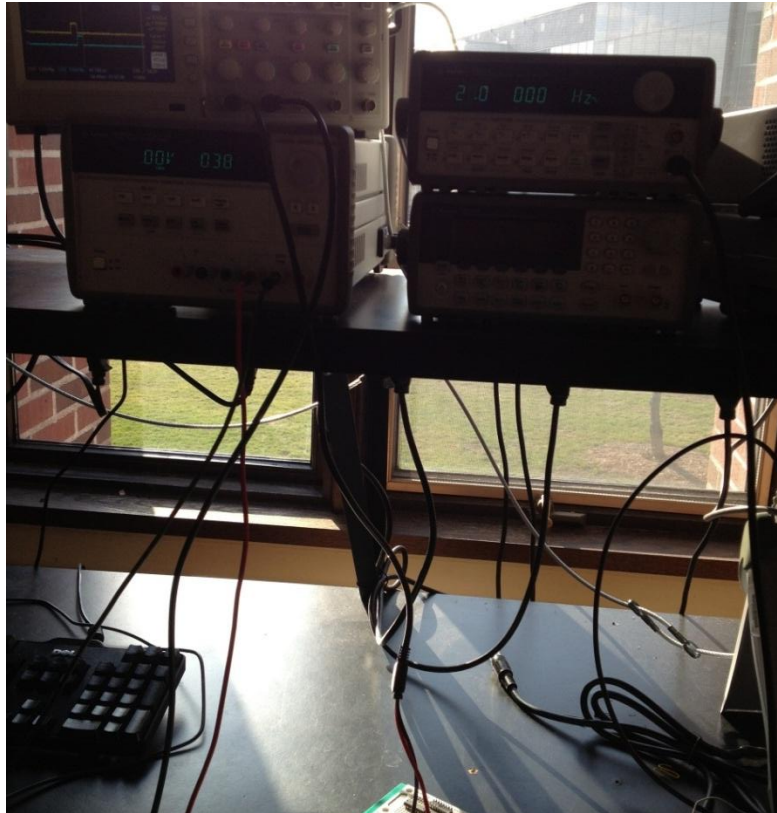

Figure 31 Testing setup

#### 4.4 Expected Results

The results expected from the circuit were consecutive pulses with width equal to the time of one clock cycle and amplitude of 5Vpp.

#### 4.5 Testing Procedure

- 1) The function generator, power supply and the DSO were used to test the circuit.
- 2) The testing was done in MWAH 393 lab of the Electrical and Computer Engineering at University of Minnesota, Duluth.
- 3) The components were assembled on the breadboard and were connected using wires.

- 4) The supply to the circuit was given through a power supply.
- 5) The function generator was used to give the clock signal to the circuit.
- 6) The working of the circuit was verified using a 4-channel DSO, where four signals could be viewed on the screen at a time, making sure that the circuit was working according to the requirements.
- 7) The circuit was tested by giving different values of the clock frequency to make sure that the circuit was working properly over the range of frequencies. We have attached the results for two values of frequency, 2Hz and 20 kHz.

## **4.6 Testing oscilloscope screenshots (2Hz)**

### 4.6.1 Checking the time of pulse

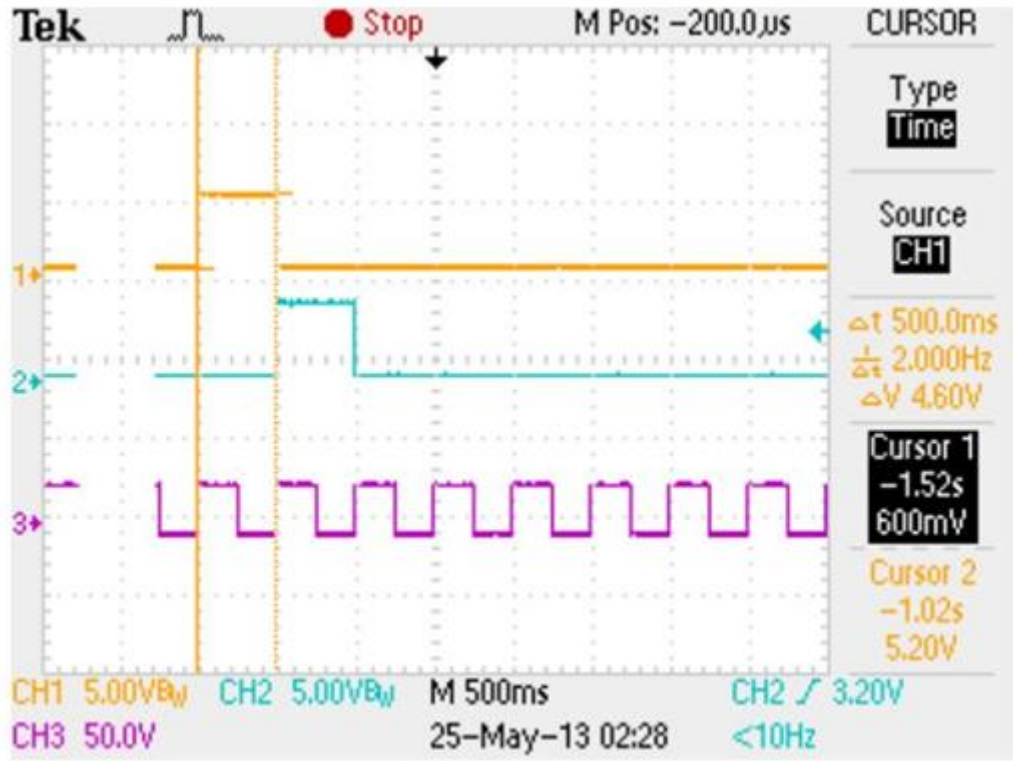

TDS 2024B - 1:10:45 PM 5/24/2013

Figure 32 Oscilloscope screenshots showing width of pulse is 500ms at 2Hz frequency

The width of each pulse is equal to the width of each clock pulse. The frequency of the clock is 2Hz. Thus, the time of each clock pulse is  $\frac{1}{2} = 0.5\text{sec} = 500\text{msec}$ . This can be verified from the figure where vertical time cursors have been inserted. The  $\Delta t$  value given by the cursor can be seen to be 500msec. Thus, it can be verified that there is no error with respect to the timing of the circuit, that is the circuit is good with respect to the timings.

4.6.2 Checking the amplitude of pulse



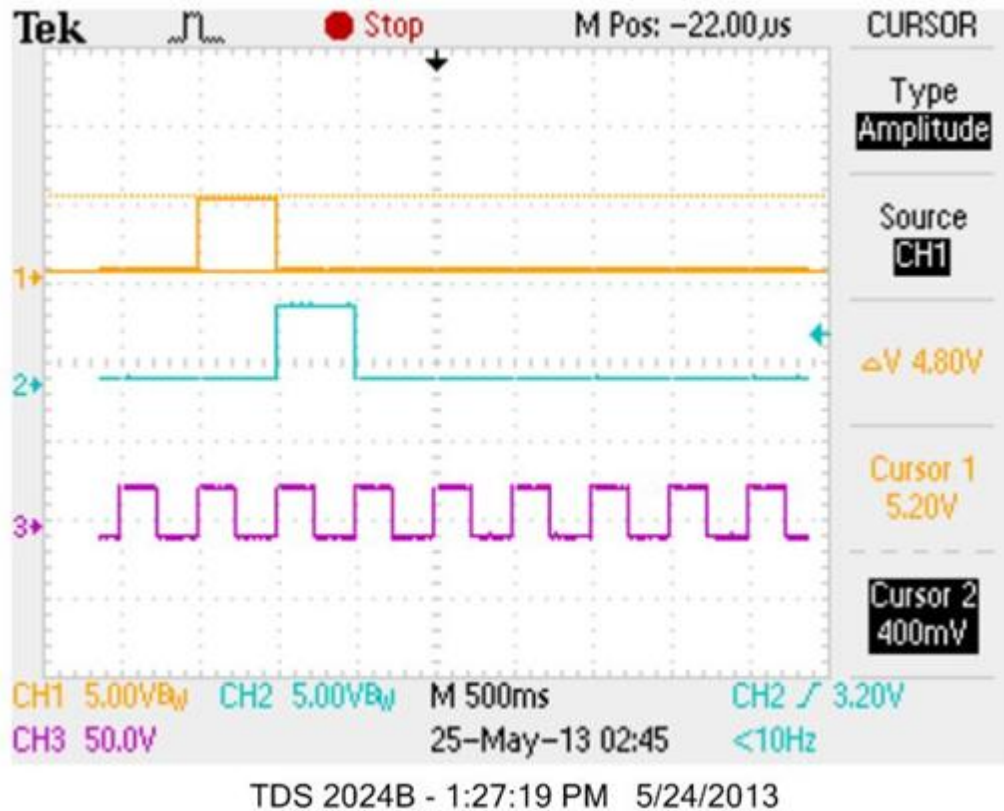

Figure 33 Oscilloscope screenshots showing amplitude of pulse is 4.8V at 2Hz frequency

The amplitude of the pulses should be 5Vpp for the application required. The  $\Delta V$  value given by the cursor can be seen to be 4.8V. There is a little deviation between the actual and expected results. The reason for this is that no chip is ideal, so it will not give an exact voltage of 5Vpp as rated. Also, there seems to be a little offset in the output voltage from the zero volt level. The reason is that TTL outputs are guaranteed to be no higher than 0.4 volts when outputting a logic 0, but they will not be exactly 0 volts.

Even then, it can be verified that this amount of deviation is tolerable and the circuit is good with respect to the amplitude.

#### 4.6.3 Checking the sequence of pulses

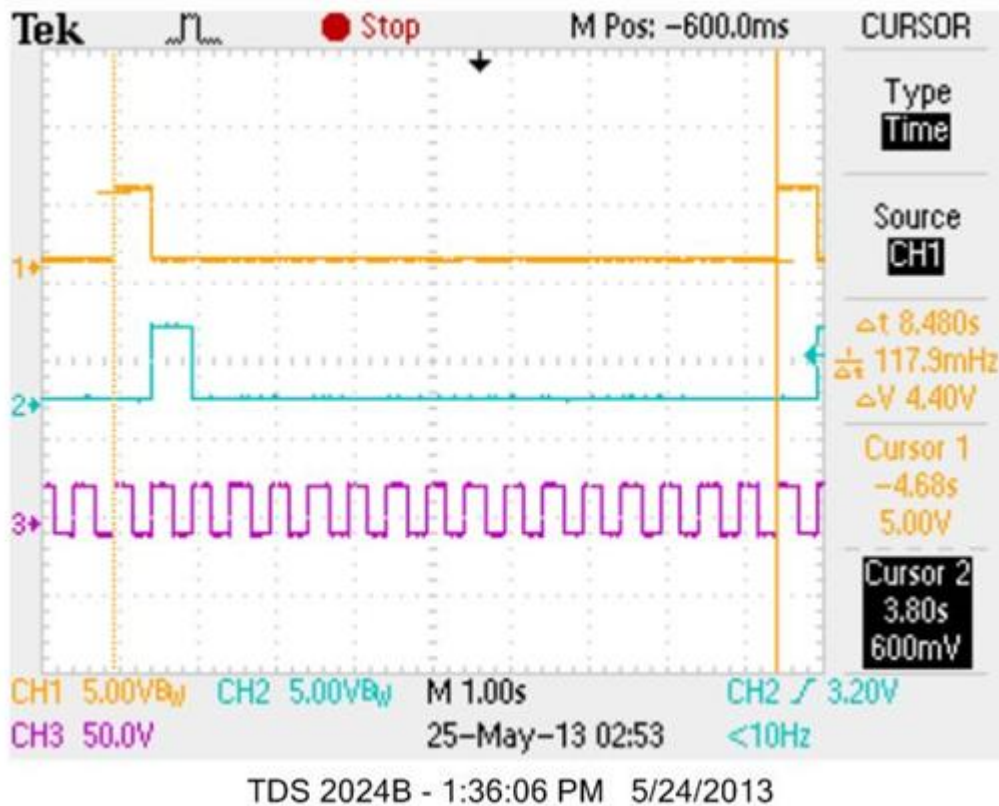

Figure 34 Oscilloscope screenshots showing sequence of pulses at 2Hz frequency

The figure 34 shows the sequence of the pulses. It can be seen from the vertical time cursors inserted that the time difference between two adjacent pulses on the same output pin is 8.50 sec which is correct because there are 17 outputs in the circuit. The duration of each pulse is 0.5 sec. Hence, the time required for 17 outputs is  $17 \times 0.5 = 8.5 \text{ sec}$ . Thus, it can be said that the pulses are repeating after the required time interval and there is no error with respect to the sequence of pulses.

## 4.7 Testing oscilloscope screenshots (20 kHz)

### 4.7.1 Checking the time of pulses

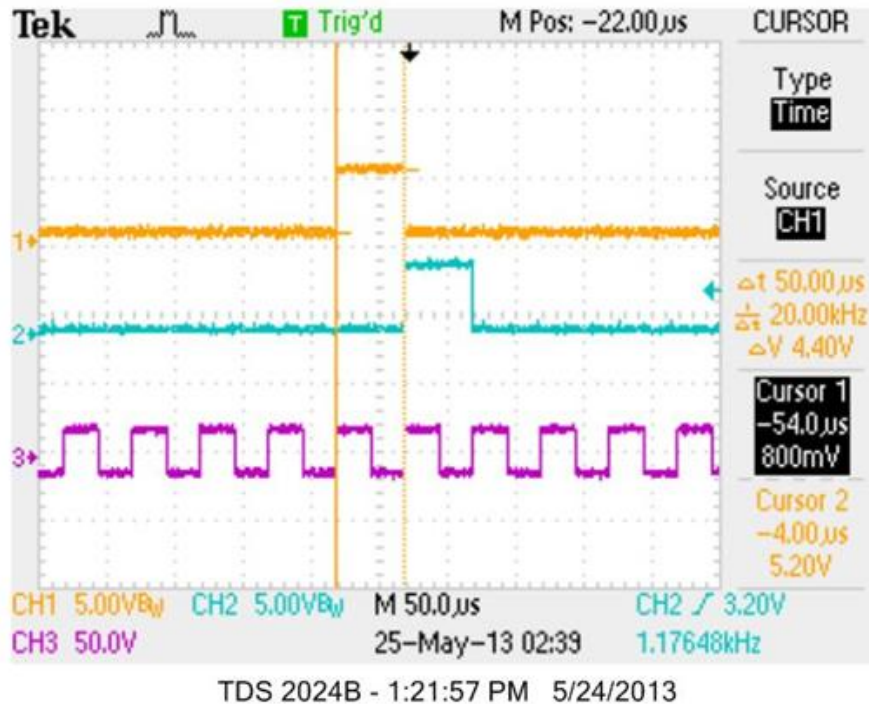

Figure 35 Oscilloscope screenshots showing width of pulse is 50us at 20 kHz frequency

The width of each pulse is equal to the width of each clock pulse. The frequency of the clock is 20 kHz. Thus, the time of each clock pulse is  $0.05\text{msec}=50\text{usec}$ . This can be verified from the figure where vertical time cursors have been inserted. The  $\Delta t$  value given by the cursor can be seen to be 50usec. Thus, it can be verified that there is no error with respect to the timing of the circuit, that is the circuit is good with respect to the timings.

#### 4.7.2 Checking the amplitude of pulses

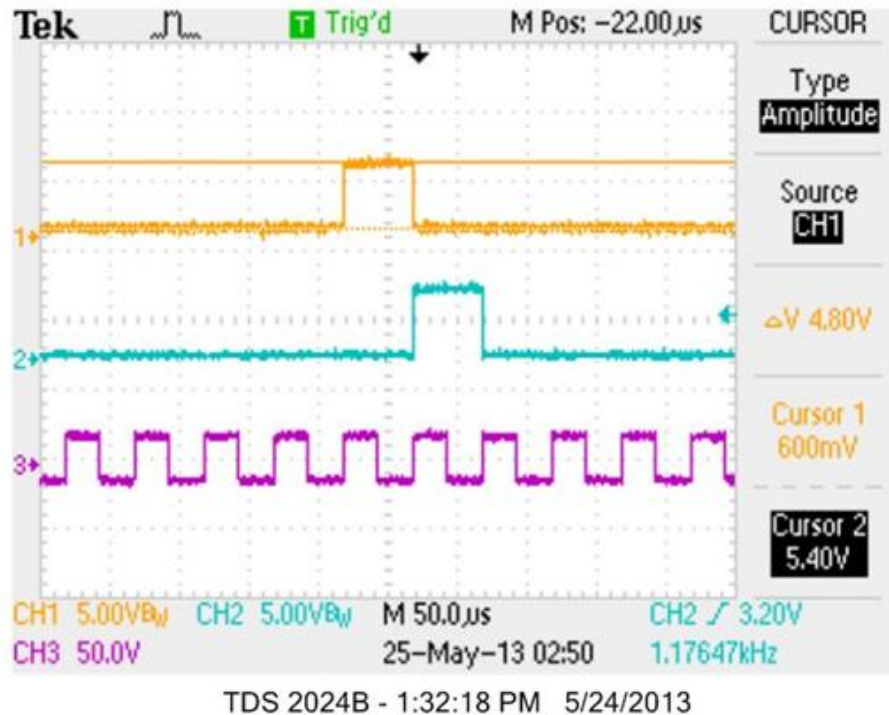

Figure 36 Oscilloscope screenshots showing amplitude of pulse is 50µs at 20 kHz frequency

The amplitude of the pulses should be 5Vpp for the application required. The  $\Delta V$  value given by the cursor can be seen to be 4.8V. Similar to the situation in the previous section, there is a little deviation between the actual and expected results. The reason for this is that no chip is ideal, so it will not give an exact voltage of 5Vpp as rated. Also, there seems to be a little offset in the output voltage from the zero volt level. The reason is that TTL outputs are guaranteed to be no higher than 0.4 volts when outputting a logic 0, but they will not be exactly 0 volts.

Even then, it can be verified that this amount of deviation is tolerable and the circuit is good with respect to the amplitude.

#### 4.7.3 Checking the sequence of pulses

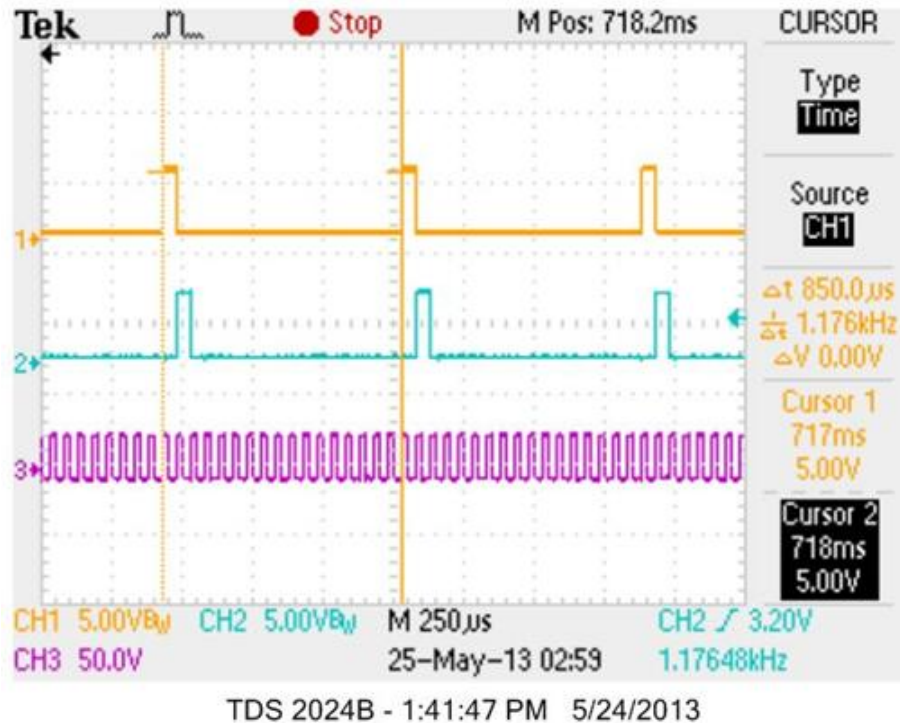

Figure 37 Oscilloscope screenshots showing sequence of pulses at 20 kHz frequency

The figure shows the sequence of the pulses. It can be seen from the vertical time cursors inserted that the time difference between two adjacent pulses on the same output pin is 850µsec which is correct because there are 17 outputs in the circuit. The duration of each pulse is 50µsec. Hence, the time required for 17 outputs is  $17 \times 50 \mu = 850 \mu \text{sec}$ . Thus, it can be said that the pulses are repeating after the required time interval and there is no error with respect to the sequence of pulses.

## 4.8 Summary of testing results

It can be seen that the testing results vary a little from the expected results.

- 1) Firstly, the output voltage is not exactly 5Vpp, but a little less than that. The reason for this error is that there is a voltage drop in any circuit and hence it is impossible to maintain the exact 5Vpp voltage.
- 2) Secondly, there is certain level of offset in the output voltage from the zero volt level. The offset is measure to be 0.3V. The reason is that TTL outputs are guaranteed to be no higher than 0.4 volts when outputting a logic 0, but they will not be exactly 0 volts.
- 3) The circuit shows similar results for both frequencies of 2Hz and 20 kHz. Though the application requires that the frequencies should be low, the circuit is also capable of working at higher frequencies.

## Chapter 5 Conclusions and future work

In this chapter, we give an overall summary of the part of the completed project and what steps need to be taken next.

### 5.1 Conclusions

As already stated earlier, the main aim of the ongoing research was to overcome the difficulty of integration from the laser-based heartbeat detection system, and develop a heartbeat detection system based on pressure sensing. The voltage provider circuit for the sensor array used for pressure sensing is a critical part of the project.

The main strategy to design the circuit which will meet all the expectations was to go through a number of circuits which give results similar to the required results. The closest circuit studied was a SIPO (Serial Input, Parallel Output) register. The D flip-flop is the most useful component of the shift register. Thus, studying the working of the D flip-flop led to a number of good ideas which could give the desired results.

The results of the research have been already presented in chapter 4. The main requirements were that the pulses should be of 5Vpp amplitude with width equal to the time of one clock cycle and the pulses should follow the sequence. It can be seen that the results fulfill the requirements. Still, there are some small errors which need to be removed from the circuit. The two main errors are that the voltage pulse is not exactly 5Vpp and there is a slight offset in the pulse voltage. Both these errors could be minimized further by using different components in the circuit. For example, using

74HC74N chip instead of the normal 74LS74N chip, that is replacing TTL by CMOS could be one of the solutions.

## **5.2 Future Work**

- 1) The final aim of the project is to manufacture a 3mmx3mm chip corresponding to each individual circuit in the project. As breadboard testing is having a few errors, first step would be to fix those errors by trying out a few methods.
- 2) After that, the next step before fabricating the chip is to manufacture a PCB and make sure that the PCB is working efficiently. The reason this step needs to be performed is to make sure that the circuit is working properly according to the requirements, before the chip is fabricated. Once the chip is fabricated, it is impossible to make any changes in that. Also, manufacturing the chip again and again is not a feasible option because it is a costly affair. Hence, before manufacturing the chip we need to be absolutely sure that the circuit design is according to our requirements.
- 3) The final step in the project would be to manufacture the chip and test the working of the chip to make sure that it is according to our requirements.



## References

- [1] Girum A. Sileshi, "Optical System Design of a Laser-Based Stethoscope", University of Minnesota Duluth, June 2012
- [2] L.A. Geddes, "Birth of the Stethoscope", Engineering in medicine and Biology Magazine, IEEE, volume 25, 2005
- [3] Dandan Song, Lijuan Jia, Yao Lu, Linmi Tao, "Heart Sounds Monitor and Analysis in Noisy Environments", 2012 International Conference on Systems and Informatics
- [4] D. Kumar, P. Carvalho, M. Antunes, J. Henriques, A. S´a e Melo, J. Habetha, "Heart Murmur Recognition and Segmentation by Complexity Signatures", 30th Annual International IEEE EMBS Conference, Vancouver, British Columbia, Canada, August 20-24, 2008
- [4] NI Multisim website accessed on 7/4/2013:  
"<http://www.ni.com/multisim/applications/>"
- [5] <http://circuitpeople.com/Blog/WhatIsAGerberFile.aspx>
- [6] McConnell, Michael E., "Pediatric heart sounds"
- [7] Mayo Clinic website accessed on 5/2/2013: <http://www.mayoclinic.com/health/heart-murmurs/DS00727>
- [8] [Health](#) Encyclopedia, University of Rochester Medical Center
- [9] Heart Disease Health Center, WebMD

[10] [Tom](#) Rice, University of Exeter, UK, “‘The hallmark of a doctor’: The stethoscope and the making of medical identity”

[11] Isaiah David, “How does a stethoscope work?”

[12] Mayo clinic website accessed on 6/2/2013:

“<http://www.mayoclinic.com/health/electrocardiogram/MY00086>”

[13] [1N4148](#) datasheet

[14] Diode datasheet

[16] Capacitor datasheet

[17] Resistor datasheet

[18] Digital Electronics by R.P. Jain