



# RESEARCH

2009-23

Development of a Platoon-Priority Control Strategy  
with/out Smart Advance Warning Flashers for  
Isolated Intersections with High-Speed Approaches

Take the



steps...

*Research...Knowledge...Innovative Solutions!*

**Transportation Research**

## Technical Report Documentation Page

1. Report No. MN/RC 2009-23	2.	3. Recipients Accession No.	
4. Title and Subtitle Development of a Platoon-Priority Control Strategy with/out Smart Advance Warning Flashers for Isolated Intersections with High-Speed Approaches	5. Report Date July 2009		6.
	7. Author(s) Henry Liu, Sundeep Bhimireddy		
9. Performing Organization Name and Address Department of Civil Engineering University of Minnesota 500 Pillsbury Dr. S.E. Minneapolis, MN 55455	8. Performing Organization Report No.		
	10. Project/Task/Work Unit No.		
12. Sponsoring Organization Name and Address Minnesota Department of Transportation 395 John Ireland Boulevard Mail Stop 330 St. Paul, Minnesota 55155	11. Contract (C) or Grant (G) No. (c) 89261 (wo) #24		
	13. Type of Report and Period Covered Final Report		
15. Supplementary Notes <a href="http://www.lrrb.org/PDF/200923.pdf">http://www.lrrb.org/PDF/200923.pdf</a>		14. Sponsoring Agency Code	
16. Abstract (Limit: 250 words)  <p>Most of the rural or suburban high-speed isolated intersections have higher traffic volumes on the major approach compared to the minor approach. The vehicle platoons on major approach are often forced to stop frequently due to conflicting calls placed by few vehicles on the minor approach. To overcome this issue, platoon-priority signal control systems have been developed to progress platoons efficiently at these intersections in a number of previous studies. In addition, Advance Warning Flashers (AWF) are used at these intersections to provide advance warning of end of green to the motorists. The conventional method uses trailing overlap green which holds the green for a fixed time after gap-out. This trailing overlap green replaces the existing dilemma-zone protection provided by loop detectors and also increases delay on the minor approach. Recently, Advance Warning of End of Green System (AWEGS) has been developed to provide advance warning at these intersections without having to hold green after gap-out. The purpose of this research study is to develop and evaluate the benefits of an integrated system which provides platoon-priority, advance warning of end-of-green, and also dilemma-zone protection at the end-of-green for rural high-speed isolated intersections. Cabinet-in-the-loop tests were performed using a real world scenario. These study results showed 50 percent reduction in delay and stops on the major approach with platoons. It was found that the total intersection delay and stops were reduced by as much as 20 percent. The system was also successful in providing advance warning to the motorists by predicting gap-outs 7 to 8 seconds earlier in the majority of the cases.</p>			
17. Document Analysis/Descriptors Platoon Priority, Advance Warning Flashers, Queuing Model, Vehicle Actuated Signal Control		18. Availability Statement No restrictions. Document available from: National Technical Information Services, Springfield, Virginia 22161	
19. Security Class (this report) Unclassified	20. Security Class (this page) Unclassified	21. No. of Pages 77	22. Price

# **Development of a Platoon-Priority Control Strategy with/out Smart Advance Warning Flashers for Isolated Intersections with High-Speed Approaches**

## **Final Report**

*Prepared by*

Henry Liu  
Sundeep Bhimireddy

Department of Civil Engineering  
University of Minnesota

**July 2009**

*Published by*

Minnesota Department of Transportation  
Research Services Section  
Transportation Bldg.  
395 John Ireland Boulevard, Mail Stop 330  
St. Paul, Minnesota 55155-1899

This report represents the results of research conducted by the authors and does not necessarily represent the views or policies of the Minnesota Department of Transportation and/or the Center for Transportation Studies. This report does not contain a standard or specified technique.

The authors and the Minnesota Department of Transportation and/or Center for Transportation Studies do not endorse products or manufacturers. Trade or manufacturers' names appear herein solely because they are considered essential to this report

## **Acknowledgements**

The authors would like to thank Susan Zarling, Minnesota Department of Transportation (Mn/DOT); Steve Misgen, Mn/DOT; and other members of the Technical Advisory Panel (TAP) for their guidance and invaluable assistance throughout this project.

# Table of Contents

<b>Part I</b>	<b>Introduction and Background .....</b>	<b>1</b>
1	INTRODUCTION.....	1
1.1	Problem Statement .....	1
1.2	Research Objectives.....	1
1.3	Report Organization.....	2
2	BACKGROUND.....	3
2.1	Platoon-Priority Signal Control Systems .....	3
2.2	Advance Warning Flasher Systems.....	3
<b>Part II</b>	<b>Analytical Model for Platoon-Priority Signal Control.....</b>	<b>6</b>
3	METHODOLOGY.....	6
3.1	Introduction.....	6
3.2	Problem Statement .....	6
3.3	Analysis .....	9
4	SIMULATION STUDY .....	21
4.1	Specific Scenario: Comparison and Calculation of Performance Measures.....	21
4.2	Sensitivity Analysis.....	23
4.3	Conclusion .....	29
<b>Part III</b>	<b>Integrated Platoon-Priority and AWF System.....</b>	<b>30</b>
5	SYSTEM DESCRIPTION .....	30
5.1	System Architecture .....	30
5.2	Integrated System.....	33
5.3	Module Descriptions.....	33
5.4	Platoon-Priority System Algorithm.....	39
5.5	Advance Warning Flasher System Algorithm.....	42
5.6	Improvements on Previous Systems .....	52
6	CASE STUDY .....	53
6.1	Cabinet-in the-Loop Architecture .....	53
6.2	Study Site.....	55
6.3	Data Collection .....	56
6.4	Simulation Study Results.....	68
<b>Part IV</b>	<b>Concluding Remarks .....</b>	<b>74</b>
7	CONCLUSION .....	74
<b>References.....</b>	<b>.....</b>	<b>75</b>

## List of Tables

Table 5-1 Time Based Dilemma-Zones .....	46
Table 6-1 T. H. 55 Speed Data Descriptive Statistics .....	62
Table 6-2 Argenta Trail Speed Data Descriptive Statistics .....	63
Table 6-3 Signal Timing Data for Argenta Trail intersection.....	66
Table 6-4 Signal Timing Data for T. H. 55 intersection.....	67
Table 6-5 Platoon-Priority System Performance.....	69
Table 6-6 Advance Warning System Performance.....	69
Table 6-7 Integrated System Performance .....	69

## List of Figures

Figure 2-1 Trailing overlap green operation .....	4
Figure 3-1 Analytical model intersection layout.....	7
Figure 3-2 Priority scheme phases.....	11
Figure 3-3 Queue length curve .....	12
Figure 3-4 Scenario tree for computation in Priority scheme.....	15
Figure 3-5 No-priority scheme phases.....	16
Figure 3-6 Queue length curve .....	17
Figure 3-7 Queue length curve .....	18
Figure 3-8 Scenario tree for computation in No-priority scheme.....	20
Figure 4-1 Priority scheme justified scenario .....	22
Figure 4-2 No-priority scheme justified scenario .....	23
Figure 4-3 Delay reduced trends.....	26
Figure 4-4 Delay reduced trends.....	27
Figure 4-5 No. of stops reduced trends.....	28
Figure 5-1 Existing system architecture .....	31
Figure 5-2 Proposed system architecture.....	32
Figure 5-3 Integrated System flowchart.....	34
Figure 5-4 Platoon-priority algorithm flowchart .....	40
Figure 5-5 AWFS algorithm flowchart .....	43
Figure 5-6 MnDOT dilemma zones and detector configuration (MN MUTCD).....	45
Figure 5-7 Predict gap-out flowchart.....	47
Figure 5-8 Simultaneous gap-out logic flowchart.....	49
Figure 5-9 Watch dog task flowchart.....	51
Figure 6-1 Cabinet-inthe-loop architecture.....	54
Figure 6-2 Cabinet-inthe-loop equipment.....	55
Figure 6-3 Study site layout.....	56
Figure 6-4 PM peak hour data (Argenta Trail intersection).....	58
Figure 6-5 PM peak hour data (T. H. 149 intersection).....	59
Figure 6-6 AM peak hour data (Argenta Trail intersection).....	60
Figure 6-7 Speed data collection sites .....	61
Figure 6-8 T. H. 55 speed data .....	62
Figure 6-9 Argenta Trail speed data.....	63
Figure 6-10 Argenta Trail intersection layout.....	64
Figure 6-11 T. H. 55 intersection layout .....	65
Figure 6-12 Advance warning time histogram (AWF, 1000 ft.) .....	70
Figure 6-13 Advance warning time histogram (AWF, 1250 ft.) .....	71
Figure 6-14 Advance warning time histogram (AWF, 1500 ft.) .....	71
Figure 6-15 Advance warning time histogram (Integrated, 1000 ft.).....	72
Figure 6-16 Advance warning time histogram (Integrated, 1250 ft.).....	72
Figure 6-17 Advance warning time histogram (Integrated, 1500 ft.).....	73

## **Executive Summary**

Most of the rural or sub-urban high-speed isolated intersections have higher traffic volumes on the major approach compared to the minor approach. Often, these intersections are not close enough to one another to provide coordination and not far enough to disperse vehicle platoons completely on the major approach. These vehicle platoons on major approach are forced to stop frequently due to conflicting calls placed by few vehicles on the minor approach. As a result, these intersections operate poorly, especially during peak periods. In addition, Advance Warning Flashers are used at these intersections to provide advance warning of end of green to the motorists. The conventional method uses trailing overlap green that holds the green for a fixed time after gap-out. This trailing overlap green replaces the existing dilemma-zone protection provided by the loop detectors and also increases delay on the minor approach. This research study developed an integrated system that provides both platoon progression and advance warning of end of green and evaluated its performance in terms of delay, stops, and advance warning time. Cabinet-in-the-loop tests were performed using a real world scenario. These study results showed 50 percent reduction in delay and stops on the major approach with platoons. It was also found that the total intersection delay and stops were reduced by as much as 20 percent. The system was also successful in providing advance warning to the motorists by predicting gap-outs 7 to 8 seconds earlier in the majority of the cases.

Also in the research study, an analytical model is proposed to study the effects of “one time green extension for vehicle platoon on major approach” (platoon-priority) on the delays in subsequent cycles of both major and minor approaches. This model was developed for a two-phased vehicle actuated signal at an isolated intersection between two one-way approaches, one is major and the other is minor. Using this model, we examined the effects of various parameters like platoon size and density, number of vehicles waiting on the minor approach, approach volumes and speeds, advance detector location on the amount of delay reduced and the number of stops reduced by giving priority to platoon.

# Part I Introduction and Background

## 1 INTRODUCTION

### 1.1 Problem Statement

Most of the rural or suburban highways have high-speed isolated intersections which have higher traffic volumes on the major approach and comparatively less traffic volumes on the minor approach. Often, these intersections are not close enough to provide coordination or not far enough to ignore platooning effect of vehicles. The vehicle actuated signal control is designed for Poisson arrivals, not for batch or platoon arrivals. Therefore, vehicle platoons from upstream intersection are often forced to stop due to the conflicting calls placed by few vehicles on minor approach. As a result, these intersections operate poorly, especially during peak periods. Recently, platoon-priority signal control systems have been developed in a number of previous studies to deal with this problem ([Wasson et al., 1999](#); [Nadeem et al., 2003](#); [Jiang et al., 2002](#)).

Furthermore, Advance Warning Flashers (AWF) are used on rural high speed signalized intersections to provide advance warning of end of green to the motorists. The conventional method uses trailing overlap green ([MN MUTCD](#)). A fixed length green-hold (trailing overlap green), typically 7 to 8 seconds, is placed at the end of phase. The advance warning beacons located upstream of intersection start flashing along with trailing overlap green. In addition, dilemma-zone detectors are used on high speed approaches to prevent a gap-out when there is a vehicle in dilemma-zone. But, when the advance warning flashers are used, there is a fixed length hold on the phase after gap-out and no more green extensions are granted afterwards. This eliminates the dilemma-zone protection provided by the detectors, and also, the routinely placed fixed time hold at the end of phase increases delay on the minor approach. Advance Warning End of Green System (AWEGS) has been developed by Texas Transportation Institute to provide advance warning without having to hold green when not necessary ([Messer et al., 2003](#)).

Both Platoon-Priority systems and AWEGS systems have a lot in common in terms of hardware requirements and operation. Both systems use advance detection to collect information regarding the future vehicle arrivals at the intersection, analyze collected information in regard to respective system objectives, and, when necessary, override normal signal controller operations to achieve their purpose. However, there is very limited literature on the integration of these systems. The purpose of this research study is to develop and evaluate the benefits of an integrated system which provides platoon-priority, advance warning of end-of-green, and also dilemma-zone protection at the end-of-green for rural high-speed isolated intersections.

### 1.2 Research Objectives

In summary, the objectives of this research study are as follows:

- Develop an analytical model to evaluate platoon-priority traffic signal control and conduct sensitivity analysis to study effects of various parameters



- Development an Integrated Platoon-Priority and Advance Warning Flasher (AWF) System for high speed isolated intersection
- Conduct hardware-in the-loop simulation tests for parameter tuning of the system for future field implementation

### **1.3 Report Organization**

Part I presents the motivation behind the research study and background literature. Part II of the report proposes an analytical model to evaluate platoon-priority signal control. It also discusses the results of sensitivity analysis tests carried out using the developed analytical model. Part III proposes integrated system architecture and presents the developed Integrated Platoon-Priority and AWF system with the descriptions of algorithms. It also presents the results of hardware-in the-loop simulation tests conducted on test intersection. Finally, Part IV summarizes the conclusions of this research study.

## 2 BACKGROUND

### 2.1 Platoon-Priority Signal Control Systems

Platoon based signal control is not new; it has been studied since 1970's. Various platoon dispersion models were developed for effective signal timing and co-ordination between a series of intersections (El-Reedy and Ashworth, 1978; Robertson, 1969; Manar and Baass, 1996; Michalopoulos and Pisharody, 1980; Yu and Benekohal, 1997). However, all these studies were focused on passive systems. The intersections' signal timing plans are programmed and coordinated based on dispersion models such that there is a smooth progression of platoons all along the corridor. One of the earliest works on active platoon-priority system is the one by Wasson et al. (1999). In this system an advance loop detector is used to detect the arrival of a platoon, and all the vehicles are assumed to travel with same speed. With this information platoon arrival pattern is estimated and green is provided during that platoon arrival time on the priority approach. Expanding this system Nadeem et al. (2003) developed and field tested a Platoon Identification and Accommodation System (PIAS). A speed trap with inductive loop detectors is used to identify vehicle type and speed at the far upstream of intersection ( $\approx 1000$  ft.). Using this information platoon arrivals at the intersection are predicted in real-time and signal controller is overrode to provide green on priority approach. The system uses low-priority preemption call to provide green on subject phases. Field test studies showed that the system was able to accommodate the detected platoons reliably and efficiently when there was light demand for conflicting phases.

Jiang et al. (2002) developed a platoon-based traffic signal timing algorithm for major-minor intersection types. This system uses variable green extensions to reduce interruptions to vehicle platoon movements on major roads. These variable green extensions are based on platoon size and average headway as detected by advance platoon detectors. The study showed through simulation results that the platoon-based signal control yielded lowest traffic delay compared to the conventional signal control methods at major-minor intersection types.

### 2.2 Advance Warning Flasher Systems

Advance Warning Flashers are used on rural high speed signalized intersections to provide advance warning of end of green to the motorists. The conventional method is to use trailing overlap method. Once the signal gaps out, a fixed length hold is placed on the phase. Typically, for a high speed approach this fixed hold length is about 7 – 8 seconds (MN MUTCD). The advance warning beacons located at 500- 800 ft. upstream of intersection start flashing as soon as the phase gaps out and continue flashing until the phase turns green again. The operation of trailing overlap green is illustrated in Figure 2-1. Dilemma-zone detectors are used on high speed approaches which avoid gap-out when there is a vehicle in dilemma-zone area. This is achieved by giving green extensions when there is a vehicle in dilemma-zone. But when Advance Warning Flashers are used there is a fixed length hold after gap-out. This eliminates the dilemma-zone protection provided by the detectors and also the routinely placed fixed hold at the end of phase increases delay on minor approach.

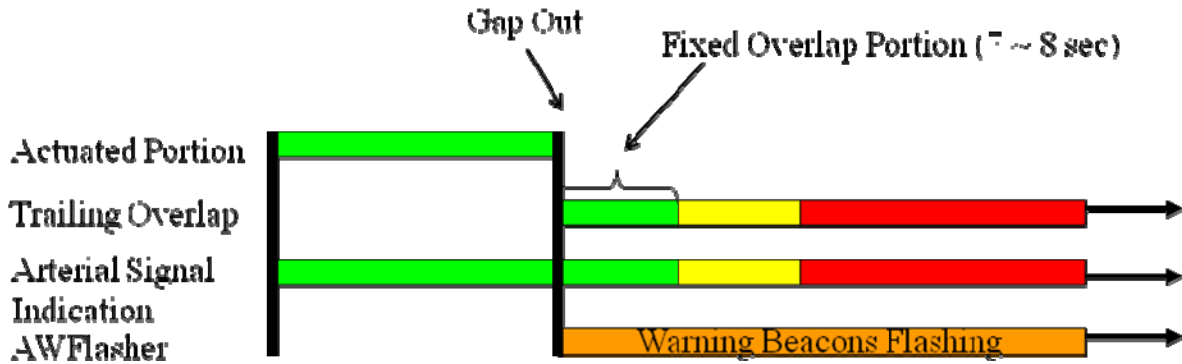

Figure 2-1 Trailing overlap green operation

Several research studies have been done on effectiveness of AWF signs. The accident studies conducted on isolated high-speed signalized intersections in California (Klugman et al., 1992) and Ohio (Pant and Xie, 1995) indicated that the advance warning signs are effective in reducing accidents. Although the results of an accident study in Minnesota (Hughes, 2000) are mixed, the study recommended advance warning signs on approaches with posted speed limit of 55 mph or higher. Another study in British Columbia (Sayed et al., 1998) indicated reduction in total number of accidents, but the reduction was found to be statistically insignificant. Mc Coy and Pesti (2002) developed a new design combining advance detection and active advance warning signs to provide dilemma zone protection. This new design was shown to reduce the frequency of max-outs, thus improving the dilemma-zone protection, over conventional dilemma-zone detector design, especially at higher volume locations.

Texas Transportation Institute has developed Advance Warning of End of Green System (AWEGS) (Messer et al., 2003). The system has two level technologies: Level 1 and Level 2. In Level 1, only one advanced inductive loop detector is used to detect the presence of vehicles upstream of the intersection. If the phase is about to gap out, and if there is a vehicle in between the advance detector and dilemma-zone detectors, a fixed hold is placed on the phase. The hold length is predetermined based on approach speed and distance between advance detectors and dilemma-zone detectors (usually 5 seconds). Therefore, the system holds the phase and provides advance warning only if there is a vehicle in the detection zone. If there are not any vehicles in dilemma-zone, advance warning is not required and not provided. But a problem with the Level 1 technology is that even though a vehicle requires less than 5 seconds it is given 5 seconds hold, this encourages the following vehicles to enter into their dilemma zone by the end of hold. Improving on Level 1, Level 2 places variable holds on the phase to accommodate a vehicle between the advance detector and first dilemma zone detector if and when necessary. This is achieved by using a speed trap instead of a single loop detector. The speed trap provides individual vehicle speeds and types. This variable hold is calculated for each vehicle individually based on vehicle speed (or travel time) and its dilemma -zone. Dilemma-zone protection is provided, only if required, for cars and trucks separately based on perception reaction times and braking power specific to vehicle type. In both Level 1 and Level 2 technology, the system predicts when the phase is going to gap out by measuring headways of vehicles upstream of

intersection at the advance detectors. The system has been field tested at two locations in Texas. During the field tests, AWECS on an average provided advance warning of 3-5 seconds about the end-of-green phase. The study results also showed that AWECS was very effective in reducing red-light –running (40-45 percent decrease).

# Part II Analytical Model for Platoon-Priority Signal Control

## 3 METHODOLOGY

### 3.1 Introduction

In this chapter we develop an analytical model to study the effects of “one time green extension for vehicle platoon on major approach” (platoon-priority or platoon-extension) on the delays in subsequent cycles of both major and minor approaches. This model is developed for a two phase vehicle actuated signal at an isolated intersection between two one way approaches. Our model is built upon the queuing model developed for a simplified adaptive control by Mirchandani and Zou (2007), with significant extensions to account for vehicle actuations after queue clearance time. The model quantifies the benefits of platoon-priority signal control in terms of amount of delay reduced and number of stops reduced; therefore it can be used to evaluate the applicability of platoon-priority signal control given the major and minor approach volumes. We shall see that platoon-priority is not always better even if there is only one vehicle waiting on the minor approach. Because, various other parameters like platoon size, average headway in the platoon, platoon speed, major and minor approach arrival rates, and advance detector location have a significant role in determining whether platoon-priority signal control is beneficial or not.

In the following section, we define an initial scenario and problem statement. Following that we present expressions for conditional expected queue discharge time, given multiple vehicles waiting at the start of green phase. We also present expressions for expected free flow time and expected number of vehicles released during a phase for a vehicle actuated signal control. We use these expressions later to analyze Priority and No-Priority signal schemes.

### 3.2 Problem Statement

Consider an isolated vehicle actuated signalized intersection with two one way streets, major (W-E) and minor (N-S) approach, without turning movements. We assume that there are only two green phases each dedicated to traffic in one direction. Let the arrival rate and intersection service rate of the major (minor) approach be  $\lambda_L(\lambda_s)$  veh/s and  $\mu_L(\mu_s)$  veh/s respectively. Let the vehicle gap extension of the major (minor) approach be  $\Delta_L(\Delta_s)$ . We will assume that there is sufficient intersection capacity so that the total flow ratio, which is summation over all the approaches,  $\rho_i = \lambda_i / \mu_i$  is less than one. We further assume that the lost times from switching to the major and minor approaches are the same, denoted by  $L$ . We assume that vehicle arrival is a Poisson process. This is reasonable given that the intersections are assumed not to be too close to each other. When intersections are located at close proximity to one another, vehicles arrive in batches and typically follow coordinated signal control. Our primary focus is on isolated signalized intersections with significant platoon formations on major approach.

### 3.2.1 Initial scenario

Now we define the situation at the intersection at time  $t = 0$ . The major approach has the green phase, but it is just about to gap out and switch from the major to the minor approach. At the same time, a platoon of size  $N_L$  with an average headway of  $h_p$  between the vehicles in platoon is detected on the major approach by the advance detectors as shown in Figure 3-1. Now the decision to be taken is whether to extend the green phase on the major approach to release the platoon (Priority scheme), or switch the green phase to serve the minor approach (No-Priority scheme). The signal control strategy of these two schemes is discussed in detail in the following sub-section. In our study we analyze both these schemes: Priority scheme and No-Priority scheme to evaluate which one will be a better signal scheme. We use performance measures, delay and number of stops, for comparing these two schemes.

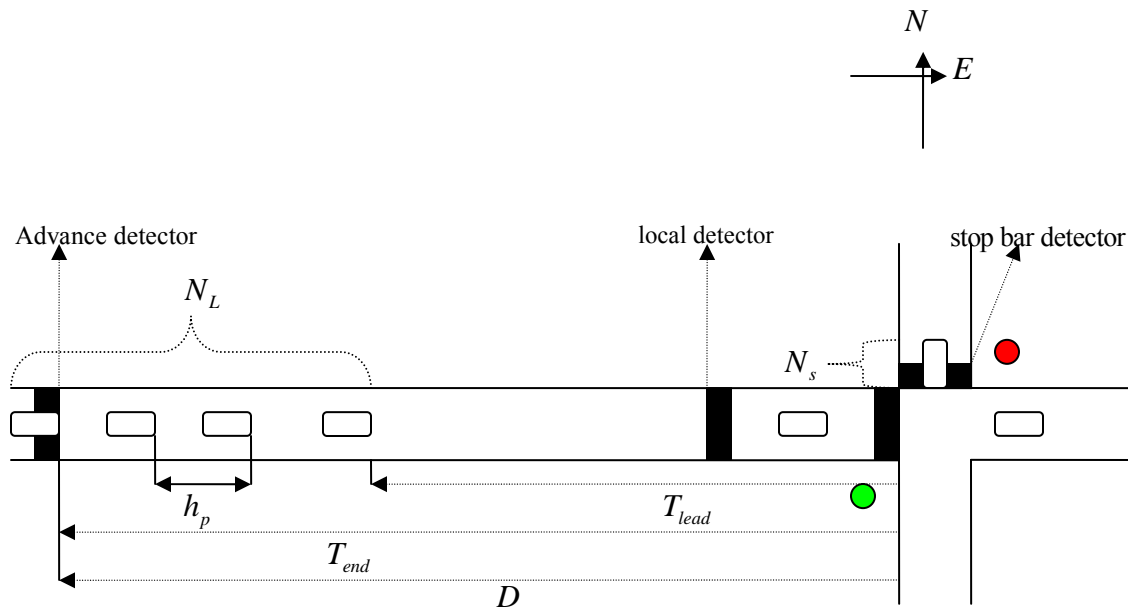

Figure 3-1 Analytical model intersection layout

$N_L$  - No. of vehicles in platoon

$N_s$  - No. of vehicles waiting on minor approach

$h_p$  - Average inter vehicle headway in platoon

$T_{lead}$  - Travel time of lead vehicle in the platoon to the stop bar

$T_{end}$  - Travel time of last vehicle in the platoon to the stop bar

$D$  - Advance detectors distance from the stop bar

### 3.2.2 *Implemented signal control strategy*

For the defined initial scenario we implement two signal schemes: Priority scheme, and No-Priority scheme. Basically, No-Priority scheme is a do-nothing alternative where the signal control operates under its normal mode i.e. through phase on major approach terminates and serves minor approach thus forcing the platoon to stop. Where as in the Priority signal scheme the green phase on the major approach is extended by a fixed time interval, depending on the advance detector location and approach speed, to accommodate the detected platoon. Once this green extension ends the signal control switches to the minor approach and goes back to its normal operation mode. No more green extensions are provided for vehicle platoons after the initial one.

Following is a brief description about the operation of vehicle actuated signal control including expressions for its expected green periods and expected number of vehicles released during that period. These expressions will be used in section 3 for analysis.

#### Vehicle actuated signal control

Each phase in a vehicle actuated signal control has two distinct parts: queue clearance time and free flow time.

a) Queue clearance time: It represents the time during which there is a presence of vehicular queue on the approach. This part of green phase ends once the queue on the corresponding approach becomes zero.

b) Free flow time: It represents the total extension period due to vehicle actuation after clearing the queue in Queue clearance time. When there is no vehicle arrival on the current approach during *vehicle extension* or *unit extension* this part of green time comes to an end and the green phase switches to its conflict approach.

#### Expected green times and number of vehicles served

##### *Queue clearance time $C_i^a$*

Let's assume that there are  $k_i$  vehicles waiting on an approach at the beginning of a green phase. Then, from queuing theory, the expected green time  $E[C_i^a | k_i]$  to dissipate this queue of  $k_i$  vehicles is given by

$$E[C_i^a | k_i] = \frac{k_i}{\mu_i - \lambda_i}$$

A detailed proof is available in Mirchandani and Zou (2007). One may simply take it as follows. Per unit time net discharge rate is  $\frac{1}{\mu_i - \lambda_i}$ . It takes time  $\frac{k_i}{\mu_i - \lambda_i}$  to clear  $k_i$  vehicles. From here

on, for the sake of mathematical maneuverability we denote  $\frac{1}{\mu_i - \lambda_i}$  by  $Z_i$  and ignore the standard notation of expected value. And therefore represent it as follows,

$$C_i^a = k_i Z_i \quad (1)$$

During queue clearance time vehicles are released at saturation flow rate. Therefore, the expected number of vehicles released during this time will be the product of queue clearance time and saturation flow rate.

$$V_1^a = k_i Z_i * \mu_i \quad (2)$$

*Free flow time  $C_i^b$*

The length of the free flow time is a function of critical gap and vehicle arrivals. The distribution and expected length of it is given by Wang (2007).

The expected free flow time is,

$$C_i^b = \frac{1}{\lambda_i} e^{\lambda_i \Delta_i} - \frac{1}{\lambda_i} \quad (3)$$

The expected number of vehicles that will be released during free flow time is given as,

$$V_i^b = e^{\lambda_i \Delta_i} - 1 \quad (4)$$

### 3.3 Analysis

#### 3.3.1 Analysis of Priority Scheme

In Priority scheme, the green phase on the major approach is extended so that the platoon could pass through the intersection without stopping. Once this green extension on the major approach ends, the green phase switches to the minor approach and the signal control goes back to its normal operation, i.e., no more green extensions are granted to the platoons here after.

For the convenience of our analysis, the time axis is divided into horizontal and vertical half cycles as shown in Figure 3-2. The horizontal (vertical) half cycles represents the green phases on major (minor) approach. Each half cycle,  $c_i$  consists of a lost time  $L$  followed by a green phase. The green phase on the major approach is extended by time  $T_{end}$  (i.e., time it takes for the last vehicle in the platoon to reach the stop bar) at time  $t = 0$ . Hence, we start with half cycle  $c_0$  of length  $T_{end}$  on the major approach (see Figure 3-2). Here the control process is Markovian. As we have assumed a known number of vehicles in the minor direction, such a starting time point



of our choice is reasonable. Since it is a vehicle actuated signal system and vehicle arrivals follow a Poisson process, the half cycle lengths  $c_1, c_2, c_3, \dots$  are random variables. Instead of using the actual length and distribution of a current half cycle to move to the next half cycle we use the expected length of the current half cycle. Fluctuation of green phases adds to the total delay, although we believe it is not significant here. Based on these expected half cycle lengths, we calculate the expected delays and number of vehicles stopped and released in each half cycle. Following is the analysis of each half cycle for Priority scheme.

### Half cycle $C_0$

The length of the half cycle is

$$C_0 = T_{end}$$

Number of vehicles  $n_0$  released during this half cycle is the major approach detected platoon size.

$$n_0 = N_L$$

Number of vehicles  $S_0$  stopped during this half cycle on the major approach is

$$S_0 = 0$$

Since the platoon is released total delay on major approach during this half cycle is zero.

$$D_0 = 0$$

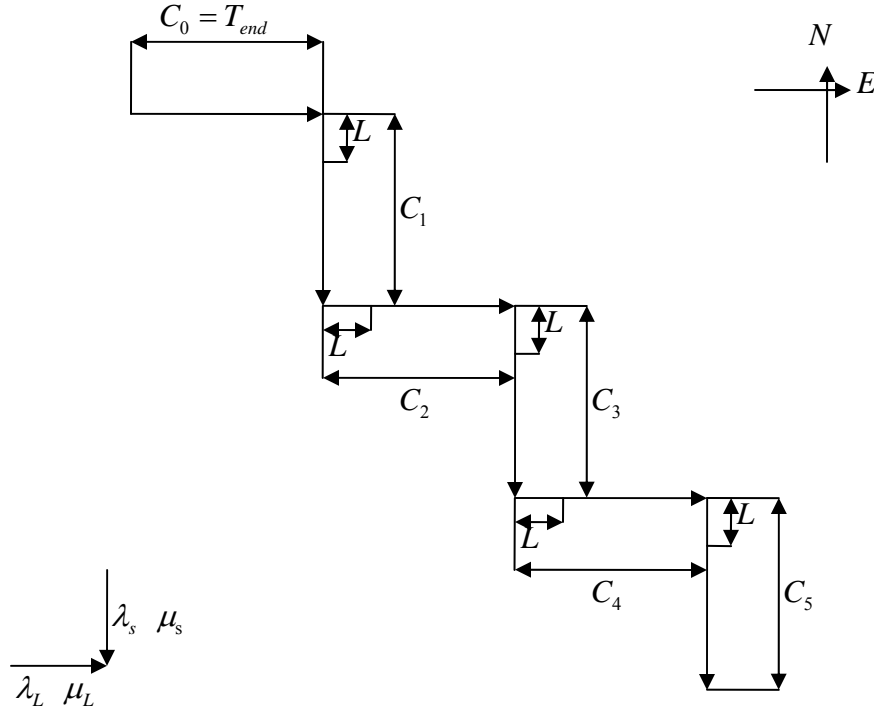

Half cycle

Figure 3-2 Priority scheme phases

At time  $t=0$  there are  $N_s$  vehicles waiting on the minor approach. Let  $X_0$  represent the number of vehicles that arrive on the minor approach during time  $C_0 + L$ . Then the probability mass function (PMF) of  $X_0$  is given by

$$P_{k_0} = P(X_0 = k_0) = \frac{[\lambda_s * (C_0 + L)]^{k_0} e^{-\lambda_s * (C_0 + L)}}{k_0!}$$

Therefore total number of vehicles waiting on minor approach at the start of green phase is  $N_s + k_0$ . From Equation 1 we can get the conditional (given  $X_0 = k_0$ ) expected queue discharge time of half cycle  $C_1$

$$C_1^a = (N_s + k_0)Z_s$$

From Equation 1 & 3 we can get the conditional (given  $k_0$ ) expected total length of half cycle  $C_1$

$$C_1 = C_1^a + C_1^b + L = (N_s + k_0)Z_s + C_1^b + L \quad (5)$$

$C_1^b$  is calculated from Equation 3. The conditional (given  $k_0$ ) expected total number of vehicles released during half cycle  $C_1$  is given by Equation 2 & 4 as

$$n_1 = V_1^a + V_1^b = (N_s + k_0)Z_s * \mu_s + V_1^b$$

The total number of vehicles stopped during cycle  $C_0 + C_1$  on minor approach is the number of vehicles that stopped during red phase  $C_0$  plus the number of vehicles that joined the queue during queue clearance time  $C_1^a$ . This total number of vehicles that are stopped during cycle  $C_0 + C_1$  and the number of vehicles that are released during queue clearance time  $C_1^a$  are the same. Therefore, the total number of stops during  $C_0 + C_1$  on minor approach is

$$S_1 = V_1^a = (N_s + k_0)Z_s * \mu_s$$

To calculate the total expected delay on minor approach during cycle  $C_0 + C_1$  we need the distribution of vehicle arrival times in this cycle. But in a Poisson process, given the number of vehicle arrivals in an interval, the arrival times of these vehicles are independently and uniformly distributed in that interval (Ross, 1997). Therefore the conditional (given  $k_0$ ) expected queue length curve during cycle  $C_0 + C_1$  on minor approach is shown in Figure 3-3.  $C_1^a$  and  $C_1^b$  are the queue discharge time and free flow time of cycle  $C_1$  respectively. Note that during free flow time queue length is zero. The conditional expected total delay  $D_1$  of minor approach vehicles during the cycle is given by the area under the curve.

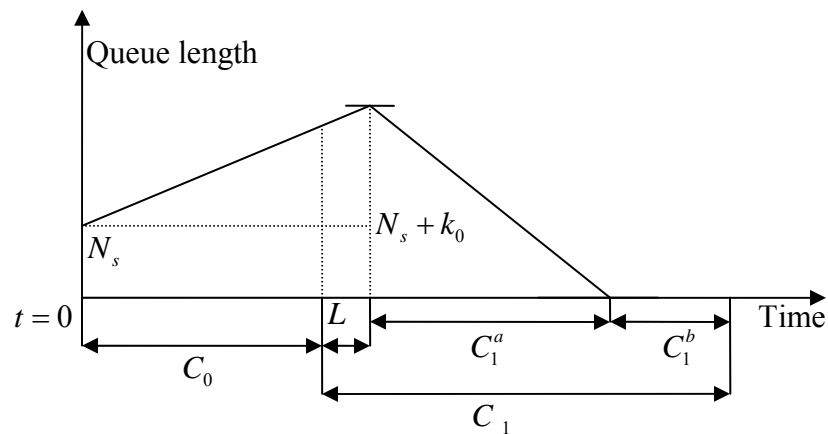

Figure 3-3 Queue length curve

$$D_1 = N_s * (C_0 + L) + \frac{1}{2} k_0 * (C_0 + L) + \frac{1}{2} (N_s + k_0) * C_1^a$$

And the unconditional expectation of total delay and total number of stops can be calculated by summing up the conditional expected delays on all possible values of  $X_0$

$$E[D_1] = \sum_{k_0=0}^{\infty} P_{k_0} D_1$$

$$E[S_1] = \sum_{k_0=0}^{\infty} P_{k_0} S_1$$

Similarly unconditional expected half cycle lengths, number of vehicles released and number of stops can be calculated for each half cycle. It should be noted that actual distribution of half cycle length is not used to calculate the unconditional expected delays. Instead, linear relationship between the conditional expected half cycle length and the number of vehicle arrivals is used. As stated earlier this wouldn't affect the results significantly.

### Half Cycle $C_2$

The conditional expected half cycle length  $C_1$  is itself a discrete random variable whose value depends upon  $k_0$ . Its distribution is given by Equation 5. Therefore calculating the PMF of  $X_1$ , the number of vehicles arriving on major approach during half cycle  $C_1 + L$ , is different. For a specific value of  $C_1 + L$  the conditional distribution of  $X_1$  is given as

$$P(X_1 = k_1 | (C_1 + L)) = P(X_1 = k_1 | k_0) = \frac{[\lambda_L * (C_1 + L)]^{k_1} e^{-\lambda_L * (C_1 + L)}}{k_1!}$$

$$\text{where } C_1 = (N_s + k_0)Z_s + C_1^b + L$$

By taking summation over all the possible values of  $C_1 + L$  one can get the unconditional PMF of  $X_1$  as

$$P_{k_1} = P(X_1 = k_1) = \sum_{k_0=0}^{\infty} P_{k_0} * P(X_1 = k_1 | (C_1 + L)) = \sum_{k_0=0}^{\infty} P_{k_0} * \frac{[\lambda_L * (C_1 + L)]^{k_1} e^{-\lambda_L * (C_1 + L)}}{k_1!}$$

Now we have the exact probability of  $k_1$  vehicles arriving on major approach during half cycle  $C_1 + L$ . As before, the conditional expected queue discharge time and total half cycle length is given by

$$C_2^a = k_1 Z_L$$

$$C_2 = k_1 Z_L + C_2^b + L$$

Note that there was no initial queue on the major approach when the half cycle  $C_1$  started. So the queue discharge time is just  $k_1 Z_L$ . The conditional expected number of vehicles released on major approach during this half cycle is given by

$$n_2 = k_1 Z_L * \mu_L + V_2^b$$

During this cycle the expected number of stops is given by

$$S_2 = V_2^a = k_1 Z_L * \mu_L$$

During this cycle the conditional expected delay on major approach is given by

$$D_2 = \frac{1}{2} k_1 (C_1 + L + C_2^a)$$

The unconditional delays and stops are given by

$$E[D_2] = \sum_{k_0=0}^{\infty} P_{k_0} \left[ \sum_{k_1=0}^{\infty} P_{k_1|C_1+L} D_2 \right]$$

$$E[S_2] = \sum_{k_0=0}^{\infty} P_{k_0} \left[ \sum_{k_1=0}^{\infty} P_{k_1|C_1+L} S_2 \right]$$

We calculate the performance measures similarly for all the succeeding half cycles till it reaches a steady state. Steady state is defined as the state at which the performance measure values of an approach in a half cycle do not differ from the values of its previous half cycle by more than a given threshold. The convergence speed depends on the total flow ratio of the intersection and the conditions during initialization. In our initialization in Priority scheme, we started out with half cycle  $C_0$  (green extension) on major approach. In No-Priority scheme, as stated earlier signal shifts to the minor approach at time  $t = 0$ , therefore we start with half cycle  $C_1$  on minor approach. These two schemes give rise to what called semi-markov renewal processes. Even though these two schemes have different initialization conditions and convergence speed, they both converge to the exact same steady state after a long enough time. In fact the only parameters that affect the final steady state are the flow rates and critical gap.

One thing that needs to be discussed here is the computational load. Since variables  $X_0, X_1, X_2, \dots$  can assume infinite possible values the number of possible scenarios goes up exponentially. The scenario tree for computation is schematically represented in [Figure 3-4](#). But if we ignore the extremely low probability scenarios, the computational load becomes manageable. At any stage, we ignore a node in the scenario tree when its probability is below a given threshold. We then can get a relationship of the various measures of interest from one half-cycle to the next one.

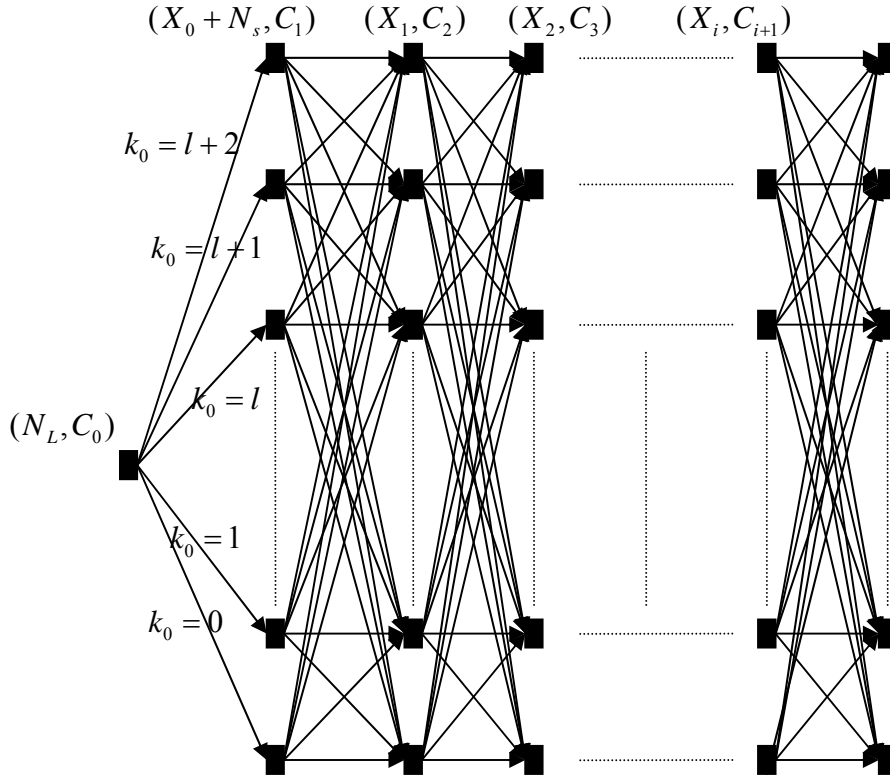

Figure 3-4 Scenario tree for computation in Priority scheme

### 3.3.2 Analysis of Non-priority Scheme

#### Half cycle $C_1$

Once again we start at time  $t = 0$ . But in this scheme of No-priority, the green phase switches from major to minor approach and the platoon on major approach is forced to stop. The half cycle-time diagram for the No-priority scheme is shown in Figure 3-5. At time  $t = 0$  there are  $N_s$  vehicles waiting to be cleared on the minor approach. In addition to these vehicles there will be  $X_0$  (random variable) vehicles arriving during lost time  $L$  of cycle  $C_1$ . If  $X_0$  takes a value  $k_0$  then the total number of vehicles to be cleared on minor approach are  $N_s + k_0$ .

The PMF of  $X_0$  is given by

$$P_{k_0} = P(X_0 = k_0) = \frac{(\lambda_s L)^{k_0} e^{-\lambda_s L}}{k_0!}$$

The conditional expected value of queue discharge time is

$$C_1^a = (N_s + k_0)Z_s$$

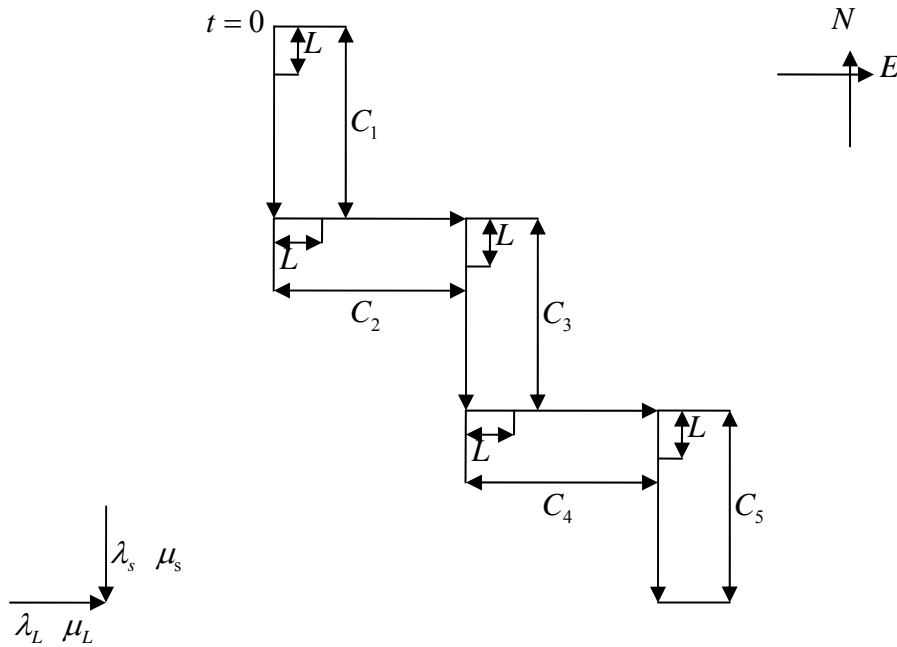

Figure 3-5 No-priority scheme phases

Then the conditional expected half cycle  $C_1$  is given by

$$C_1 = (N_s + k_0)Z_s + C_1^b + L$$

The conditional expected number of vehicles released during this half cycle on minor approach is

$$n_1 = (N_s + k_0)Z_s * \mu_s + V_1^b$$

The conditional expected number of vehicles stopped is

$$S_1 = (N_s + k_0)Z_s * \mu_s$$

The expected queue length curve in this case is shown in [Figure 3-6](#).

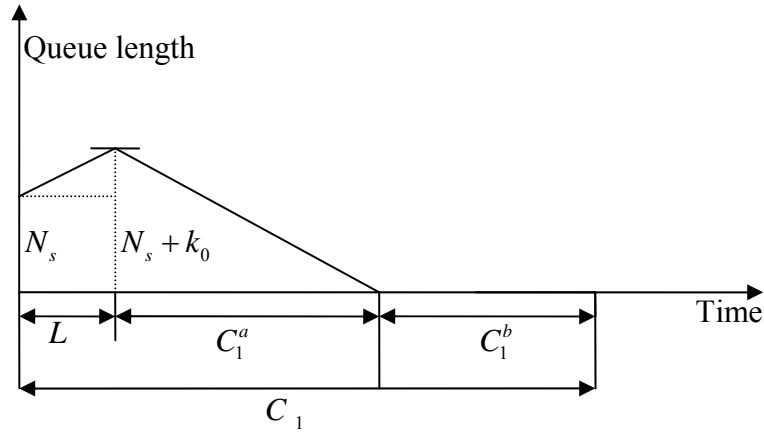

Figure 3-6 Queue length curve

The expected total delay is given by the area of the triangle

$$D_1 = N_s * L + \frac{1}{2} k_0 * L + \frac{1}{2} (N_s + k_0) * C_1^a$$

The unconditional delays and stops are given by

$$E[D_1] = \sum_{k_0=0}^{\infty} P_{k_0} D_1$$

$$E[S_1] = \sum_{k_0=0}^{\infty} P_{k_0} S_1$$

### Half cycle $C_2$

Since there are no vehicles in front of the platoon, the first vehicle to arrive at the intersection is the lead vehicle of the platoon. Until the last vehicle of the platoon joins the queue, vehicles arrive at a constant rate of  $1/h_p$ . Vehicles that arrive after the platoon follow a Poisson process.

Let  $X_1$  represent the number of vehicles that arrive after the platoon during the half cycle  $C_1 + L$ . Therefore these  $X_1$  vehicles arrive at the intersection during the period  $C_1 - T_{end} + L$ .

Therefore, the conditional distribution of  $X_1$  is given by



$$P(X_1 = k_1 | (C_1 - T_{end} + L)) = P(X_1 = k_1 | k_0) = \frac{[\lambda_L * (C_1 - T_{end} + L)]^{k_1} e^{-\lambda_L * (C_1 - T_{end} + L)}}{k_1!}$$

where  $C_1 = (N_s + k_0)Z_s + C_1^b + L$

Unconditional distribution of  $X_1$ ,

$$P_{k_1} = P(X_1 = K_1) = \sum_{k_0=0}^{\infty} P_{k_0} * P(X_1 = k_1 | (C_1 - T_{end} + L)) = \sum_{k_0=0}^{\infty} P_{k_0} * \frac{[\lambda_L * (C_1 - T_{end} + L)]^{k_1} e^{-\lambda_L * (C_1 - T_{end} + L)}}{k_1!}$$

The conditional expected queue discharge time is

$$C_2^a = (k_1 + N_L)Z_L$$

The conditional expected half cycle length is

$$C_2 = (k_1 + N_L)Z_L + C_2^b + L$$

The conditional expected number of vehicles released is

$$n_2 = (k_1 + N_L)Z_L * \mu_L + V_2^b$$

The conditional expected number of vehicles stopped is

$$S_2 = (k_1 + N_L)Z_L * \mu_L$$

The conditional expected queue length curve is shown [Figure 3-7](#).

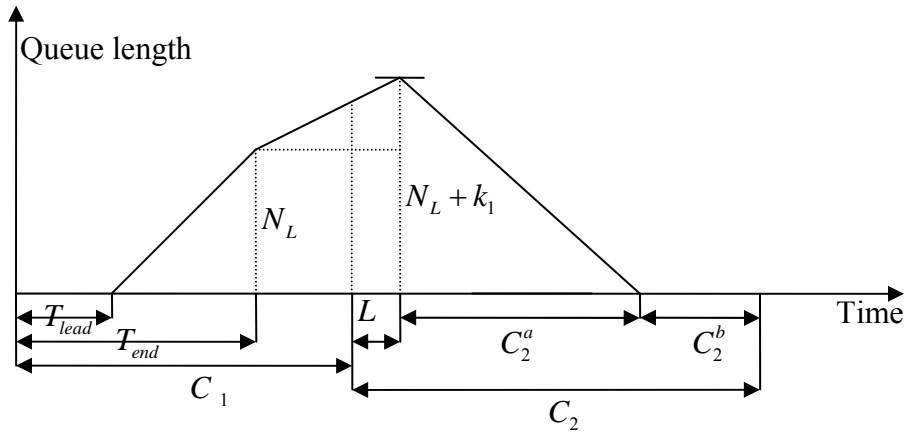

Figure 3-7 Queue length curve

The conditional expected total delay is given by

$$D_2 = \frac{1}{2}N_L * (T_{lead} - T_{end}) + N_L * (C_1 - T_{end} + L) + \frac{1}{2}k_1 * (C_1 - T_{end} + L) + \frac{1}{2}(k_1 + N_L) * C_2^a$$

The unconditional delays and stops are given by

$$E[D_2] = \sum_{k_0=0}^{\infty} P_{k_0} \left[ \sum_{k_1=0}^{\infty} P_{k_1|C_1-T_{end}+L} D_2 \right]$$

$$E[S_2] = \sum_{k_0=0}^{\infty} P_{k_0} \left[ \sum_{k_1=0}^{\infty} P_{k_1|C_1-T_{end}+L} S_2 \right]$$

Half cycle  $C_3$

Conditional distribution of  $X_2$ ,

$$P(X_2 = k_2 | (C_2 + L)) = P(X_2 = k_2 | k_1) = \frac{[\lambda_s * (C_2 + L)]^{k_2} e^{-\lambda_s * (C_2 + L)}}{k_2!}$$

where  $C_2 = k_1 Z_s + C_2^b + L$

Unconditional distribution of  $X_2$ ,

$$P_{k_2} = P(X_2 = k_2) = \sum_{k_1=0}^{\infty} P_{k_1} * P(X_2 = k_2 | (C_2 + L)) = \sum_{k_1=0}^{\infty} P_{k_1} * \frac{[\lambda_s * (C_2 + L)]^{k_2} e^{-\lambda_s * (C_2 + L)}}{k_2!}$$

The conditional expected queue discharge time is

$$C_3^a = k_2 Z_s$$

The conditional expected half cycle length is

$$C_3 = k_2 Z_s + C_3^b + L$$

The conditional expected number of vehicles released is

$$n_3 = k_2 Z_s \mu_s + V_3^b$$

The conditional expected number of vehicles stopped is

$$S_3 = k_2 Z_s \mu_s$$

The conditional expected delay is given by

$$D_3 = \frac{1}{2}k_2(C_2 + L + C_3^a)$$

The unconditional delays and stops are given by

$$E[D_3] = \sum_{k_1=0}^{\infty} P_{k_1} \left[ \sum_{k_2=0}^{\infty} P_{k_2|C_2+L} D_3 \right]$$

$$E[S_3] = \sum_{k_1=0}^{\infty} P_{k_1} \left[ \sum_{k_2=0}^{\infty} P_{k_2|C_2+L} S_3 \right]$$

Similar procedure is followed for all the succeeding half cycles until it reaches a steady state. The scenario tree for computation of No-priority scheme is shown in Figure 3-8.

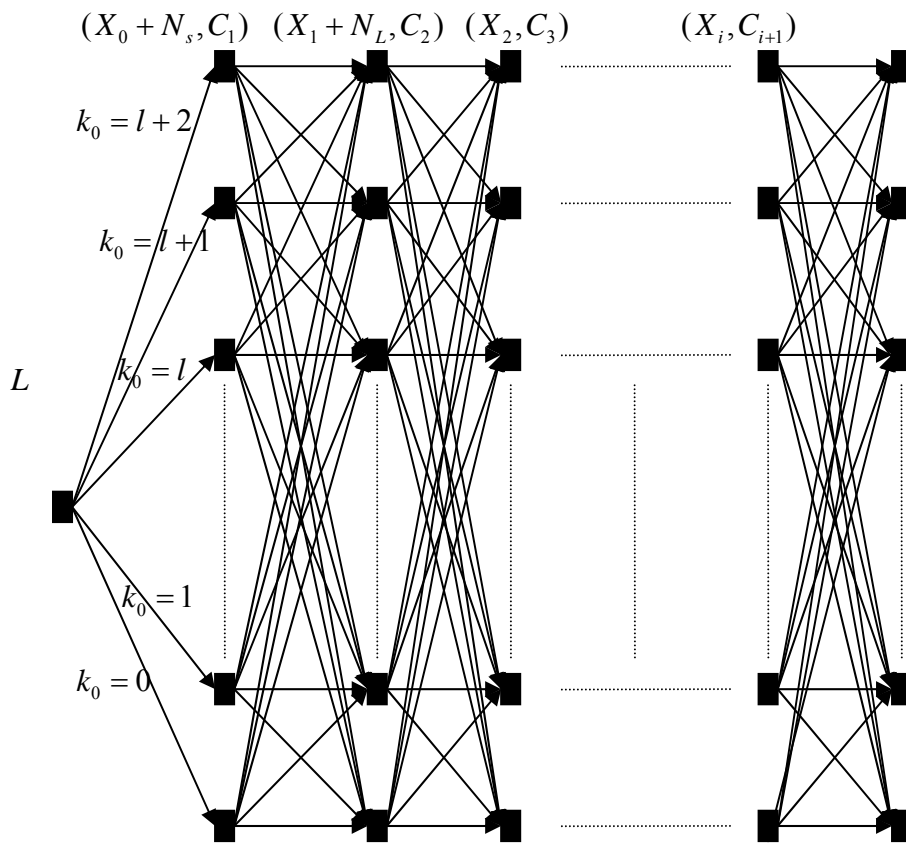

Figure 3-8 Scenario tree for computation in No-priority scheme

## 4 SIMULATION STUDY

The above discussed model is built in MATLAB to evaluate No-priority scheme and Priority scheme for several different initial scenarios. For each of these scenarios we calculate performance measures in terms of reduced cumulative delay and reduced number of stops. We discuss about the estimation of these performance measures later. Based on these measures conclusions can be drawn on whether Priority or No-priority scheme improves signal performance for a given initial scenario and set of parameters.

For all the scenarios tested, service rate of 1900 vph was assumed on both approaches. Advance detectors location from the stop bar and major approach speed were set to 1000 ft. and 55 mph. Vehicle extension or critical gap of 3 seconds was assumed on both approaches. Average headway in between the vehicles in a platoon was set to 1.5 seconds. Lost time  $L$  of 4 seconds per half cycle was assumed. Keeping these parameters fixed at these values the effects of platoon size, number of vehicles waiting on the Minor approach, major and minor approach volumes on performance measures were studied. In the following section, using a specific scenario we demonstrate the calculation of performance measures, reduced cumulative delay and reduced number of stops.

### 4.1 Specific Scenario: Comparison and Calculation of Performance Measures

For estimating the performance measures, delay reduced and number of stops reduced, it is not appropriate to plot and compare the estimates of delay and number of stops for Priority and No-priority scheme against time scale. Because the number of vehicles that were released and the number of vehicles that are present in the system at any point of time is different for both schemes. And it is easy and intuitive to compare these estimates on the basis of number of vehicles released. Therefore, the performances measures are plotted against number of vehicles released.

Take a specific 4-1 case (i.e., platoon size is 4 vehicles and one vehicle waiting on the minor approach) where major approach and minor approach volumes are 600 and 200 vph. Cumulative delay versus number of vehicles released is shown in [Figure 4-1-1](#). The difference between the graphs of No-priority scheme and Priority scheme (No-priority delay – Priority delay) at any point in the [Figure 4-1-2](#) is the cumulative amount of delay reduced at that point by giving platoon-extension. Amount of delay reduced is plotted against the number of vehicles released in [Figure 4-1-3](#). As shown in the graph cumulative amount of time saved converges after few half cycles but fluctuates between two values due to two different half cycles, one on major and the other on minor approach. The lower point is chosen as the total amount of delay reduced by giving platoon-extension as that would be the least amount reduced at any point. For this scenario the total delay reduced by giving platoon-extension would be at least 5.9 seconds. In a similar manner, number of stops reduced can be calculated. Cumulative number of stops is plotted against number of vehicles released in [Figure 4-1-3](#). Number of stops reduced versus number of vehicles released is shown in [Figure 4-1-4](#). The number of stops reduced also converges after few half cycles. And the number of stops reduced by giving Priority to platoon is

3.7 which is slightly less than platoon size. In addition to the performance measure, delay, the number of stops also shows that Priority is better for this scenario. Unlike in this scenario, sometimes the performance measures contradict each other. Following is an example of one such scenario.

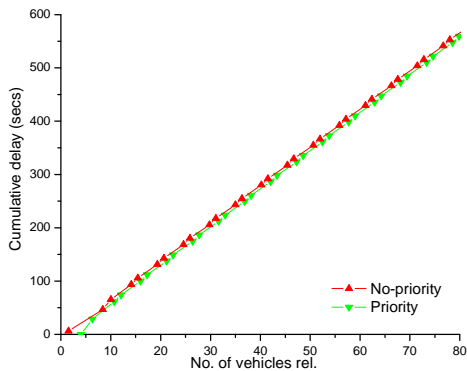

Fig. 9.1 Cumulative delay Vs No. of vehicles released

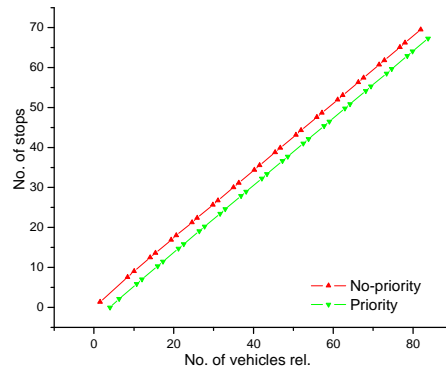

Fig. 9.3 No. of stops vs No. of vehicles released

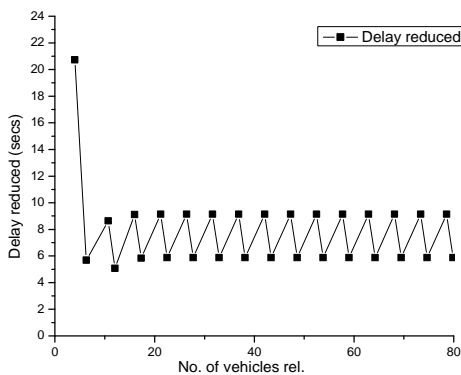

Fig. 9.2 Delay reduced Vs No. of vehicles released

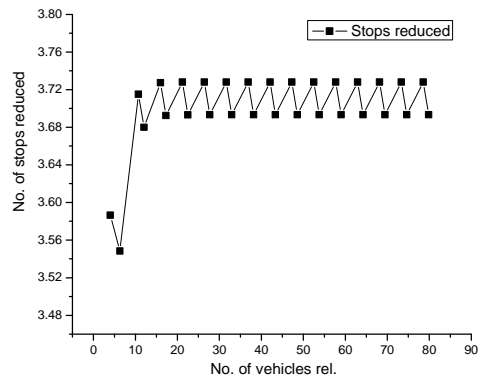

Fig. 9.4 No. of stops reduced vs No. of vehicles released

### Figure 4-1 Priority scheme justified scenario

For the second scenario, major and minor approach volumes were changed to 900 vph and 300 vph. And all the other remaining parameters were kept the same. The resultant graphs were presented in [Figure 4-2](#). In the graph cumulative delay versus no. of vehicles released, the Priority and No-priority curves are intertwined together. And therefore, it can be seen in [Figure 4-2-2](#) that the delay reduced is fluctuating between positive and negative values from point to point. But in [Figure 4-2-4](#) the performance measure, number of stops reduced, clearly indicates that Priority control reduces number of vehicle stops. For this scenario conclusion cannot be made on whether Priority or No-priority is better than the other, easily. In this type of situations the tradeoff between the additional delays imposed and reduced fuel emissions should be considered. These types of situations require a great deal of engineering judgment and

experience to handle. Currently, there is no an agreeable procedure for this. Nonetheless, the analytical model results should provide a basis for traffic engineers to make better engineering decisions.

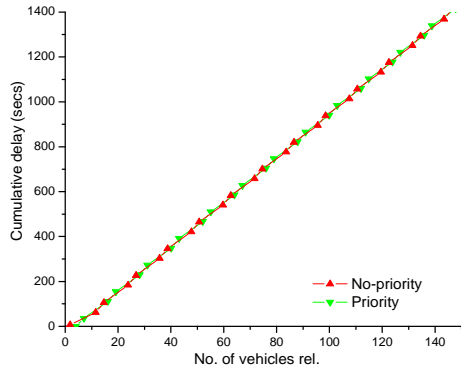

Fig. 10.1 Cumulative delay Vs No. of vehicles released

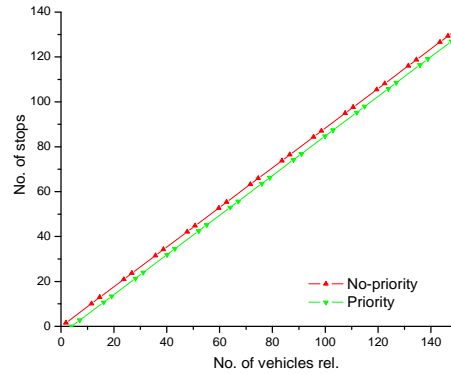

Fig. 10.3 No. of stops vs No. of vehicles released

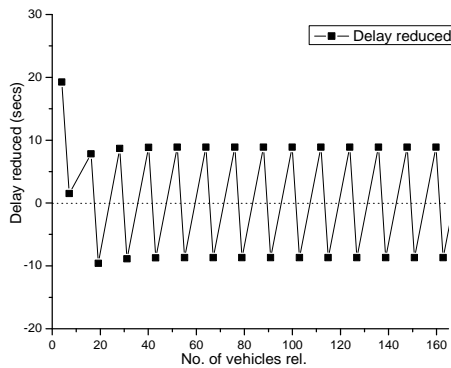

Fig. 10.2 Delay reduced Vs No. of vehicles released

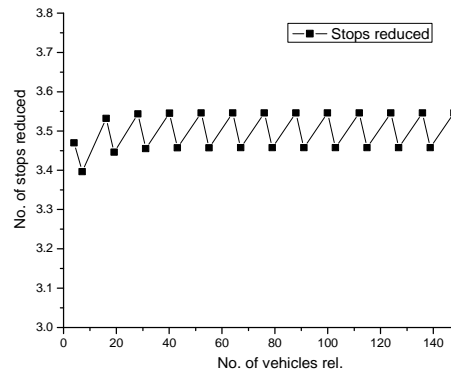

Fig. 10.4 No. of stops reduced vs No. of vehicles released

Figure 4-2 No-priority scheme justified scenario

## 4.2 Sensitivity Analysis

With all the other parameters fixed, studies were conducted by varying the parameters like platoon size, number of vehicles waiting on the minor approach and arrival rates on both the approaches. For all these scenarios the performance measures, delay reduced and number of stops reduced, were calculated as explained in the previous section and presented here. Figure 4-3, 4-4 shows the variations of estimated delay reduced with major approach volume, minor approach volume, platoon size and number of vehicles waiting on the minor approach. Figure 4-5 shows the variations of estimated number of stops reduced with the changes in above mentioned parameters.

#### 4.2.1 *Effect of major approach volume*

When the platoon size is 4 and 5, as the major approach volume increases the performance measure, delay reduced, decreases. This is expected because the platoon size is fixed while the major approach volume is increased. To illustrate this trend let us consider a hypothetical case where the major approach has a volume of 3600 vph. At this level of flow rate a vehicle is expected at every second on an average. In this situation it is not feasible to extend the green phase on major approach by 12.5 secs (1000 ft. advance detector location and 55 mph approach speed) to allow a platoon of 4 vehicles to pass through the intersection. Instead it is better to end the green phase now and release these vehicles at saturation flow rate in the next cycle. At this extreme case No-priority scheme outperforms Priority. Hence, as the major approach volume increases the performance measure, delay reduced, decreases. In 4-1 case when the major approach volume is greater than or equal to 800 vph, No-priority scheme performs better than Priority scheme in terms of delay.

However, this trend should not be confused with the popular belief that as the major approach volume increases and minor approach volume decreases the benefits of platoon based signal timing increases. In our research our interest is only on the benefit of one time green extension for a platoon. Even though the benefit of one time extension decreases as the major approach volume increases, more vehicles travel in platoons consequently increasing the number of platoon extensions (assuming the extensions are justified). This increase in number of platoon extensions increases the total benefits in longer durations.

As the platoon size increases to 6 and 7, it can be seen in [Figures 4-3 & 4-4](#) that the trends change and curves tend to become concave upwards. Because, releasing a platoon of 6 vehicles in 12.5 seconds is close to the saturation flow rate of the approach. And releasing 7 vehicles in 12.5 seconds is higher than the saturation flow rate. It is advantageous to make use of these situations and give green extension to platoon. Therefore in No-priority scheme where platoon is not granted extension, as the major approach volume increases it drastically affects and increases the delays. This results in an increase in the amount of delay reduced as the major approach volume is increased. [Figure 4-5](#) illustrates the trends of reduced number of stops with major approach volume for different minor approach volumes and platoon cases. For the same reasons listed, in case of lower platoon sizes the estimate, number of stops reduced, decreases as major approach volume increases. And at platoon size of 7 vehicles the estimate of reduced number of stops increases as the major approach volume increases.

#### 4.2.2 *Effect of minor approach volume*

[Figure 4-3, 4-4](#) shows the variations in the amount of delay reduced with minor approach volume for different cases of platoon of sizes and major approach volume. Basically it follows two trends. When Priority is justified, as the minor approach volume increases the amount of delay reduced also increases. On the other hand, when Priority is not justified as the minor approach volume increases the amount delay reduced decreases. The reason for this is there are two different things happening as the minor approach volume increases. In Priority scheme, it results in increased minor approach delay because more number of vehicles join the queue on minor

approach during major approach green extension. Where as in the No-priority scheme, as the minor approach volume increases the delay caused to the platoon also increases because the green phase length on the minor approach increases. For the scenarios where Priority is justified, platoon delay in No-priority scheme plays a major role that is why as the minor approach volume increases the amount of delay reduced increases in the area above x-axis. But for the scenarios where No-priority is justified, increased minor approach delay in Priority scheme plays a major role and the graph trend changes below x-axis.

Figure 4-5 illustrates the variation of reduced number of stops with minor approach volume. The performance measure, number of stops reduced, is always positive for all the tested scenarios. Therefore, priority is justified for all the tested scenarios according to the performance measure reduced number of stops. Hence, as the minor approach volume increases the performance measure number of stops reduced also increases.

#### 4.2.3 *Effect of platoon size*

In Figure 4-3, 4-4 it can be seen that as the platoon size increases the amount of delay reduced also increases. This is expected because as the platoon size increase more vehicles are released with zero delay which increases the signal performance. Figure 4-5 illustrates the variation of performance measure, number of stops, reduced with platoon size. As the platoon size increases the number of stops reduced also increases. This is also expected because as the platoon size increases more vehicles pass through intersection without stopping.

#### 4.2.4 *Effect of number of vehicles waiting on the minor approach*

From Figure 4-3, 4-4 it can be seen that as the number of vehicles waiting on the minor approach increases the amount of delay reduced decreases. This is expected because as the initial queue length on minor approach increases to large values No-priority scheme is favored. This means that as the minor approach queue length increases benefits decrease. However, in the case of performance measure number of stops reduced, the parameter number of vehicles waiting on the minor approach doesn't have any effect on the number of stops reduced (Figure 4-5). They remained same up to the level of sixth decimal even though number of vehicles waiting on the minor approach is varied.



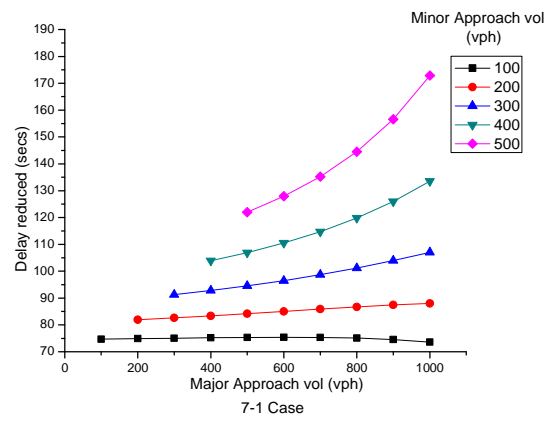
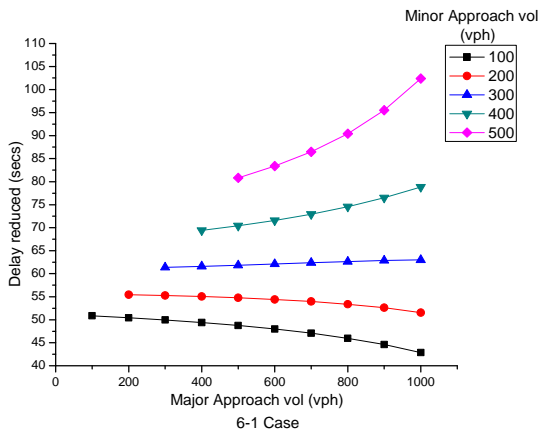
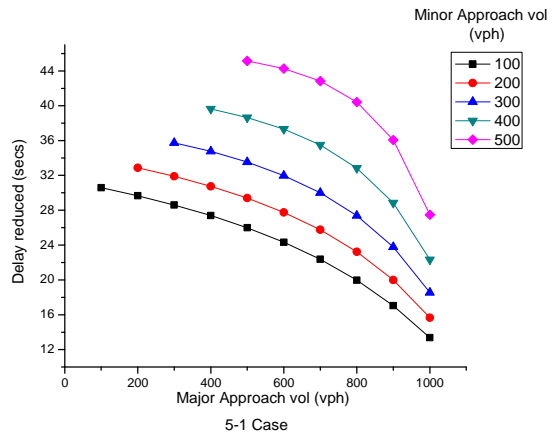
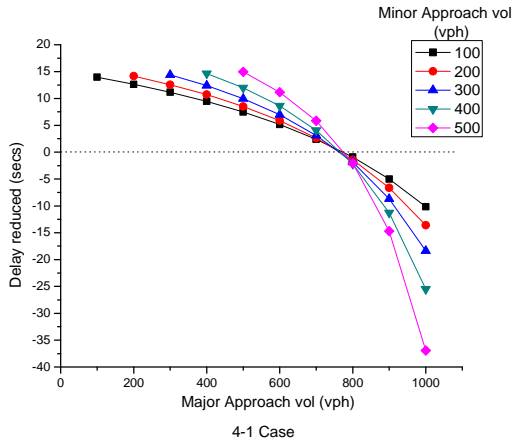

Figure 4-3 Delay reduced trends

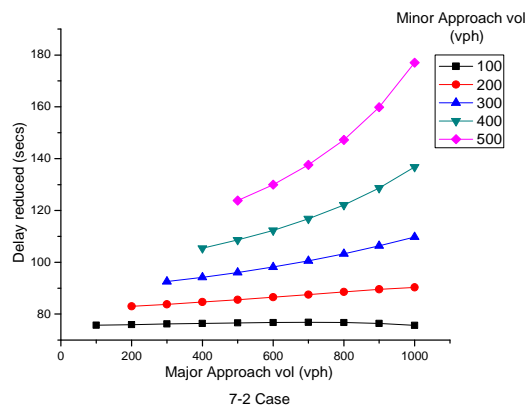
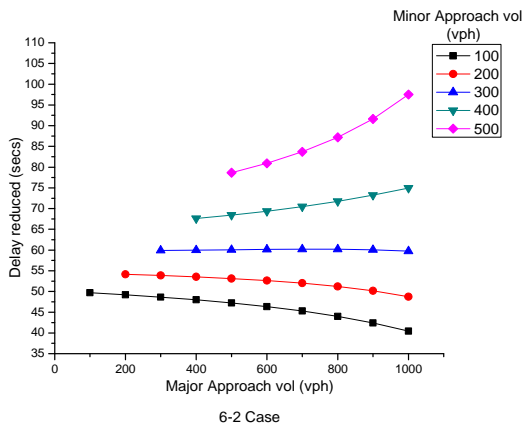
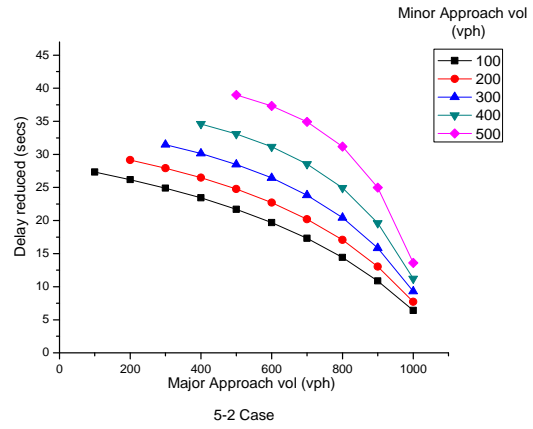
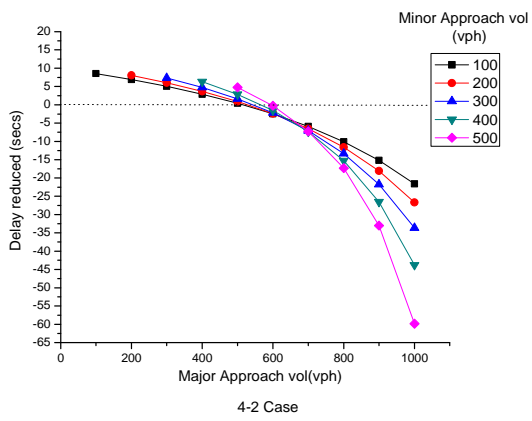

Figure 4-4 Delay reduced trends

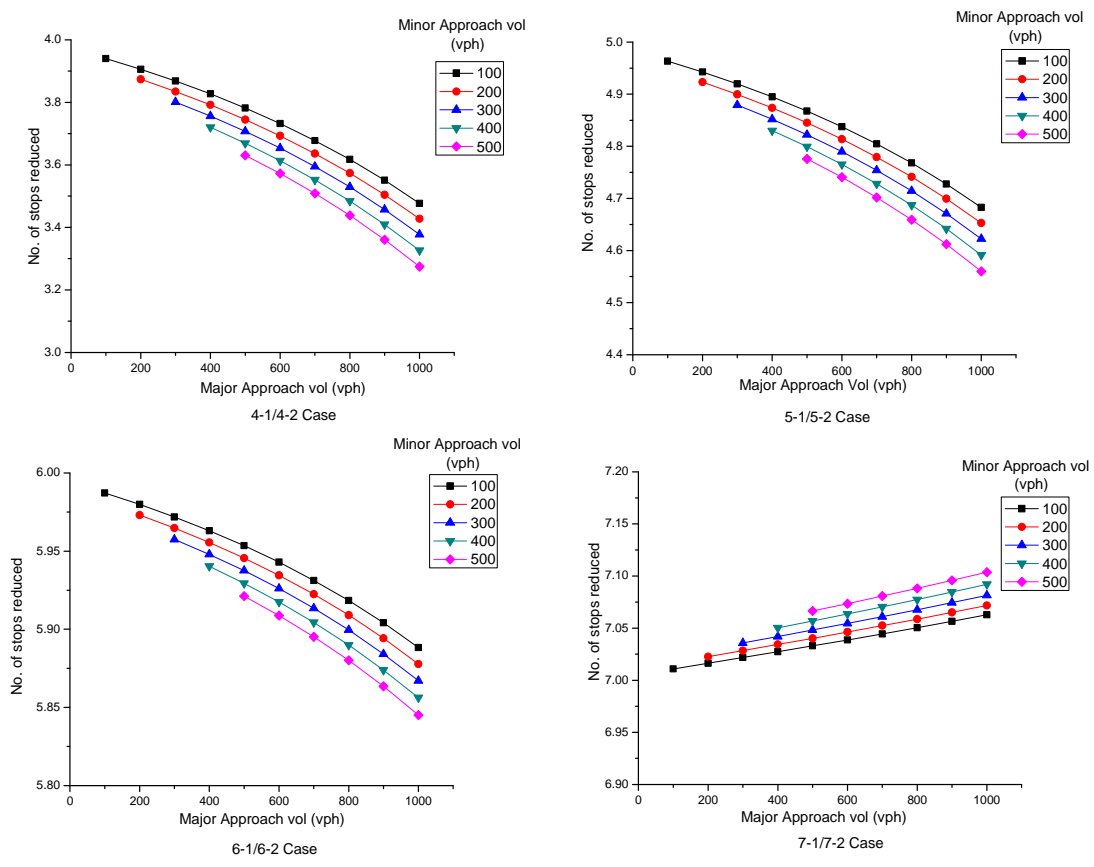

Figure 4-5 No. of stops reduced trends

### 4.3 Conclusion

An analytical model is proposed to estimate the benefits of platoon priority for simple intersection of two one way streets operating under vehicle actuated signal control. For a defined initial scenario we implement two signal schemes Priority and No-priority. The two schemes, No-priority and Priority are compared with each other until they both reach steady state. The convergence speed and point of time at which they both reach the steady state might be different. The total accumulated benefits like delay reduced and number of stops reduced are calculated at a point where both the schemes have reached the steady state. These estimated benefits have been achieved by giving only one time green extension for the first platoon at time  $t=0$  and leaving the system alone to reach steady state. In most scenarios, 70-90 % of the total end accumulated benefit at a point where both have reached the steady state is achieved with in the first cycle after giving platoon-extension. Therefore, the total benefit of giving multiple “one platoon-extension per cycle” in a longer duration period would be much larger and an approximate value can be easily estimated, assuming such extensions granted were justified according to the analysis done in this study.

A sensitivity analysis study was conducted on the effects of flow rates, platoon sizes and other significant parameters on the benefits of platoon-extension. It was found that in certain situations platoon-priority control does not improve the signal performance in terms of the performance measure, delay, even though there was only one vehicle on the minor approach. On the contrary, the performance measure, number of stops, indicated that the platoon-priority control is always better.

# Part III Integrated Platoon-Priority and AWF System

## 5 SYSTEM DESCRIPTION

### 5.1 System Architecture

The existing and proposed Integrated System architecture layouts are illustrated in [Figures 5-1 and 5-2](#). Similar architecture has been used in previous studies ([Chaudhary et al., 2003](#); [Messer et al., 2003](#)). In the existing system, phase detector status is sent to the traffic controller via cabinet back panel. In return, signal status is sent to the cabinet which controls the signal status at the intersection. In addition to this in the proposed system, advance detector information is collected from classifier by an industrial PC running integrated system algorithm. The algorithm also collects signal status from cabinet back panel. After processing the input information, if necessary, the algorithm overrides normal signal operation to accommodate platoons and to provide dilemma zone protection. It also activates advance warning flashers when the main street through phases are predicted to gap out. National Instruments Data Acquisition (NIDAQ) card is used to provide communication between the cabinet back panel and industrial PC.

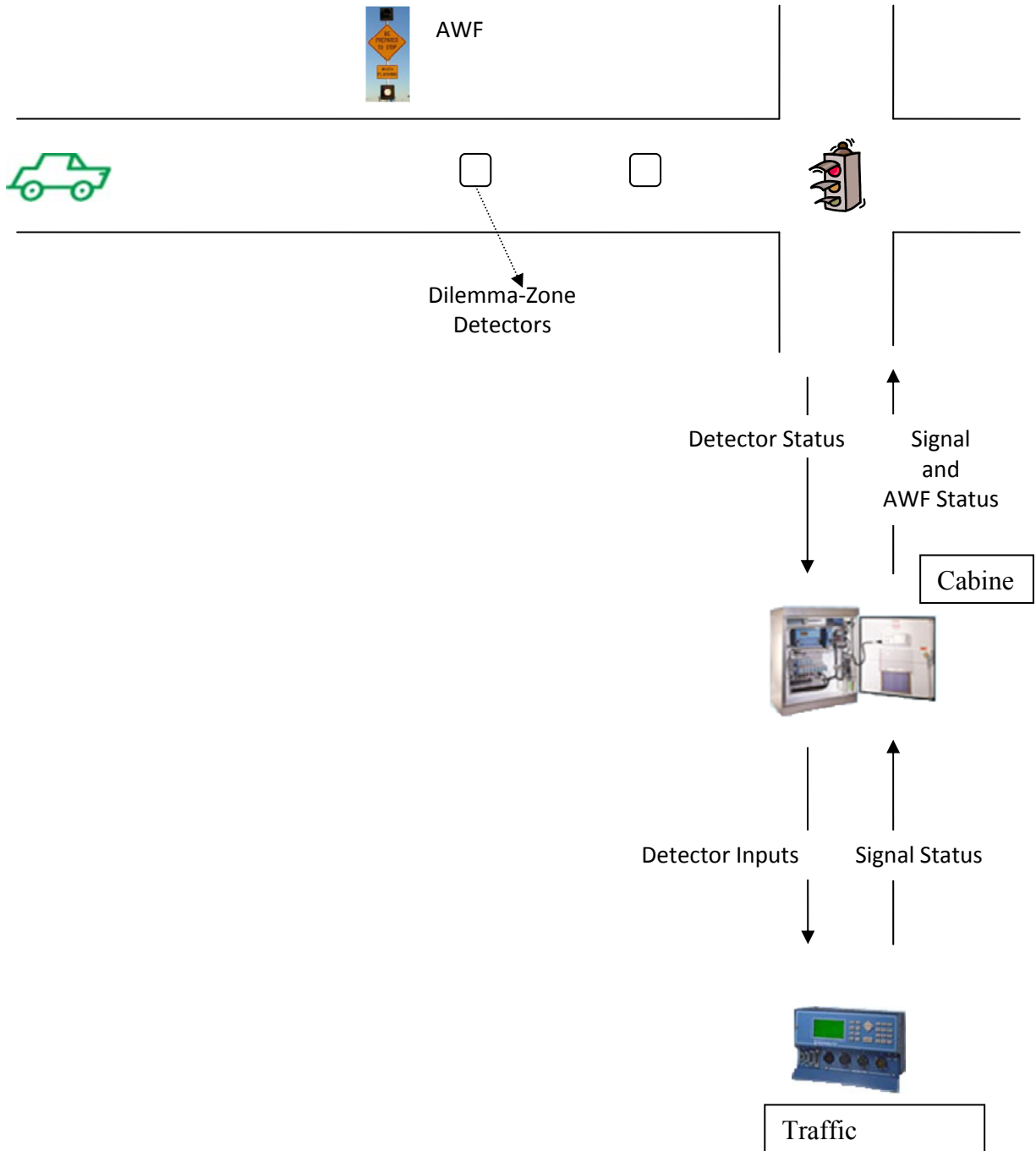

Figure 5-1 Existing system architecture

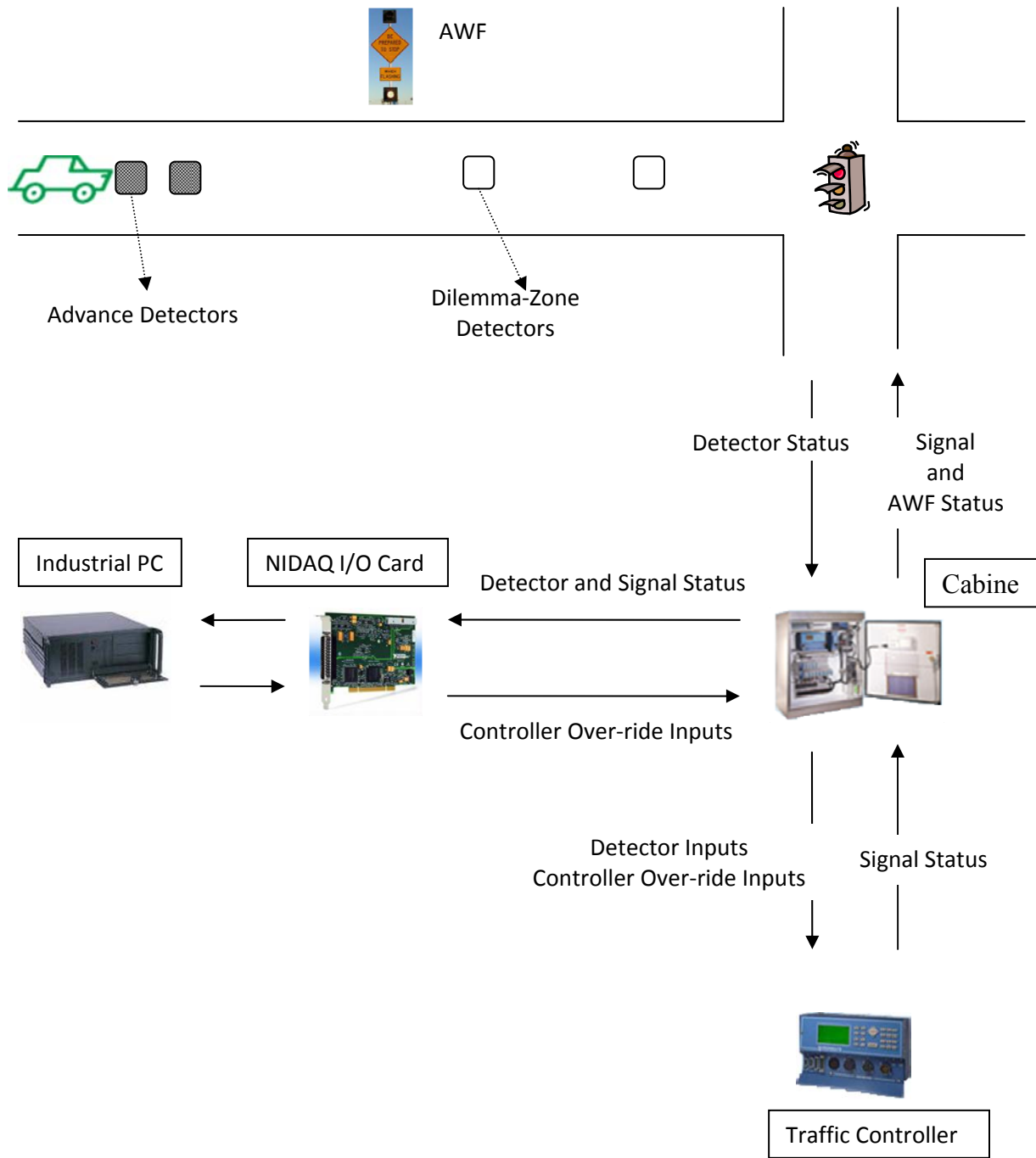

Figure 5-2 Proposed system architecture

## 5.2 Integrated System

The Integrated System uses advance loop detectors (speed trap) and a computer, installed with Integrated System software, to know about future events such as platoon arrivals and dilemma-zone detector actuation times at the intersection. The algorithm estimates the travel time of each vehicle detected at advance detectors to each dilemma-zone detector in its lane and to the stop bar. This is done by assuming that the vehicles travel at same speed as measured by the speed trap from advance detectors to the stop bar and the vehicles do not over take or change lanes. The system overrides normal signal controller operation, using a combination of Transit-Signal Priority (TSP) call and phase-hold, to provide platoon-priority to the detected platoons for an identified priority-phase. In addition, with the future phase detector actuation time information and controller status information, the system predicts future phase gap-outs and provides advance warning of end of green to the motorists on main street phases. Also, the system provides dilemma-zone protection using phase-holds to both cars and trucks separately. The Integrated System software consists of eight different tasks that are performed in a loop in real time as shown in [Figure 5-3](#). Each of these task duties are briefly described below in the order of their execution.

## 5.3 Module Descriptions

### 5.3.1 *Controller Status Data Acquirer*

This task acquires signal status information and phase detector information from the controller via the cabinet back panel. A digital Input/Output card is used to facilitate communication between cabinet back panel and computer. The signal status information is deduced from Phase  $\Phi$  Green On and Ring Status Bit pin terminals in the cabinet. Essentially, Phase  $\Phi$  Green On pins provide the phases that are being served now and Ring Status Bit pins provide the yellow and red clearance period intervals for the phases.



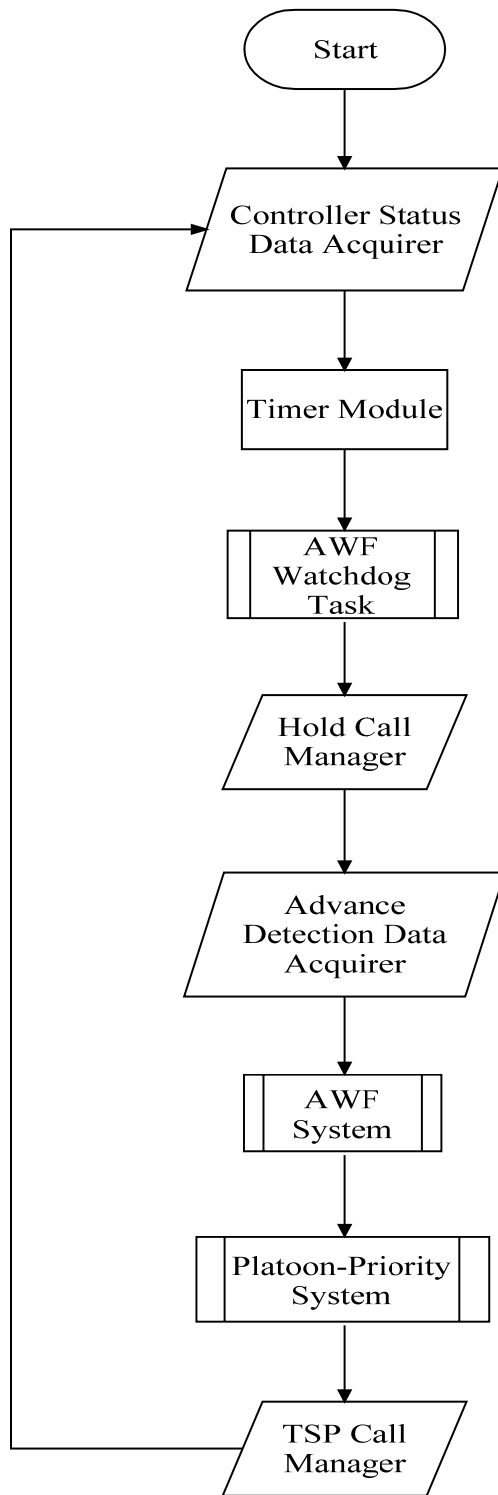

Figure 5-3 Integrated System flowchart

### 5.3.2 *Timer Module*

This task uses the signal timing plan data such as minimum green, maximum green, added seconds per actuation, maximum initial. Timer Module keeps track of minimum green timer, added initial time, and max green timer for each main street through phase separately and updates them in real time. The algorithm includes features such as detector-locking memory in order to update or reset the maximum green timer according to the calls placed or removed on conflicting phases. Also, to estimate the added initial portion of a phase, the algorithm keeps count of number of detector actuations received during the non-green portion of a phase. Depending on the number of actuations, seconds per actuation parameter, and maximum initial green time parameter set for the phase, the algorithm decides the appropriate added initial time for the phase.

### 5.3.3 *AWF Watchdog Task*

This is a watchdog alarm task included in the system to respond safely to unexpected gap outs. Even though the AWF System is designed to accurately predict the green phase terminations, it has limitations. The system assumes that all the vehicles that pass over the advance detectors are through movements and includes them in dilemma-zone detector actuation times, but some of these vehicles may be turning movements which may not pass over all the dilemma zone detectors. Also, the system assumes that the vehicles travel at constant speed when, in fact, the motorists may slow down or accelerate as they approach the intersection. These assumptions result in unexpected gap outs. To accommodate these cases, the watchdog alarm task keeps track of passage timer and identifies any impending gap outs within next 0.2 seconds. The system supports simultaneous gap out feature provided in controllers. The task also verifies if there are any phase-hold calls placed by the Hold Call Manager while determining gap outs. If the algorithm determines that the green phase is going to terminate in the next 0.2 seconds, the algorithm calls Dilemma-Zone Protection module (DZP) to provide dilemma-zone protection. The Dilemma-Zone protection module is described in detail later. In short, it places a hold on the phase if there are any vehicles that will be caught up in their respective dilemma-zones. If the DZP module has not placed a phase hold, the watchdog task activates the advance warning flasher beacons immediately. Or else, the watchdog alarm task determines that the phase is not going to terminate and waits to evaluate in the next loop cycle.

### 5.3.4 *Hold Call Manager*

The Hold Call Manager manages the phase hold calls placed on main street through phases (AWF phases) and platoon-priority phase. If there is a hold-phase request from the DZP module or the Platoon-Priority Scheduler since the previous execution time, the algorithm places a hold on the respective phase. If there is currently a hold placed on a phase, the algorithm will remove or continue it based on the duration requested by DZP or Platoon-Priority Scheduler. The hold calls are placed on Phase  $\Phi$  hold input pins via the cabinet back panel.

### 5.3.5 Advance Detection Data Acquirer

In order to predict future arrival times of vehicles at the stop bar and the dilemma zone detectors, the algorithm needs information about the approaching vehicles in advance. The algorithm needs vehicle detection time at the advanced detectors location, vehicle speed, and vehicle type to estimate arrival times. This data is acquired by the Advance Detection Data Acquirer from a vehicle classifier (if a speed trap with inductive loops is used). Video detection system can also be used to acquire the required data. But the previous research studies (Nadeem et al., 2003) indicated concerns about video detection and stated that inductive loops are more reliable. The whole system performance relies on vehicle arrival times estimated from advance detection data. Therefore, accurate advanced detection data is very critical to the system.

### 5.3.6 AWF System

The AWF System estimates the future arrival times of vehicles on to its each dilemma zone detector for each lane. It also estimates the detector presence time depending on vehicle's speed and type. Using this information and phase timing data parameters like minimum green timer, maximum green timer the algorithm predicts the phase gap-out time. The algorithm estimates the phase detector on and off times based on vehicle arrival times and detector presence times, and then it searches for a detector off period which is greater than the passage time set in the controller. As the algorithm searches for the period, it removes any information related to the detector on/off times that are deemed to extend the green. This process continues for each phase until the interval is found or it runs out of advance information provided by the advanced detection. If the algorithm runs out of advance detection information and there are not any new vehicle information over the advance detectors, it waits until critical hot time. Critical hot time is the estimated last detector off time plus the difference between passage time and the threshold travel time between the advance detectors and first dilemma zone detector. This threshold travel time is computed using the 99 percentile speed. Once the critical hot time expires the algorithm declares that the phase is going to gap out. If a detector off period greater than passage time is found, then the passage timer's expiration time in that period is the phase's gap-out time. The algorithm features simultaneous gap-out feature used on most of the isolated high-speed approach intersections. With the presence of simultaneous gap-out logic, both phases 2 and 6 needs to gap out simultaneously or one phase gap-out and the other max-out or both phases max-out to cross the barrier. In the absence of simultaneous gap-out logic, both phases gap-out individually and the first one to gap-out waits for the other to gap-out to cross the barrier. In this mode, once a phase gaps out it ignores any future vehicle calls and does not extend its green. These both logics are programmed into the algorithm and anyone can be used depending on intersection setting.

Once the algorithm determines that the AWF phases are going to terminate, it checks if there is going to be a phase hold during the determined green termination time. If there is a hold then the algorithm determines that the phase is not going to gap-out and waits to evaluate in the next loop cycle. If there is no hold placed, then the algorithm calls the Dilemma-Zone Protection module. DZP module provides dilemma-zone protection, only if required, by a placing a hold the respective phase. If the DZP module doesn't place a call, then the task turns on the advance warning flasher beacons. Otherwise, it waits until next loop cycle to predict phase gap-out.

### 5.3.7 *Platoon-Priority System*

This module detects future platoon arrivals at the stop bar using the data provided by the advance detection system. The algorithm only keeps track of last  $n$  (minimum number of vehicles that can be deemed as a platoon or minimum platoon size) vehicles that passed over the advance detectors on a First-in First-out (FIFO) basis. The algorithm has two stages for platoon-priority scheduling:

- Platoon Identification Stage
- Platoon Extension Stage

During the Platoon Identification Stage, the algorithm evaluates the last  $n$  vehicles on a rolling horizon basis. If the difference between the arrival times of first and last vehicle of the last  $n$  vehicles detected at the stop bar is less than a pre-determined arrival time threshold value ( $T$ ), the algorithm recognizes the group of vehicles as a platoon and schedules an initial platoon-priority interval with start and end times. Once the initial platoon-priority interval is scheduled, the algorithm switches to Platoon Extension Stage. During this stage, all additional vehicles that pass over the detector are evaluated individually to determine whether they are a part of the previously detected platoon. This is determined by comparing the headway between the subject vehicle and the last vehicle of the platoon with a pre-defined extension threshold value ( $T_e$ ). If the headway is less than the threshold value, the algorithm extends the initially scheduled priority interval end time to accommodate the current vehicle. This process continues until a headway that does not meet the threshold criterion is found or the maximum priority green time is reached. The algorithm parameters - minimum platoon size ( $n$ ), arrival time threshold value ( $T$ ), and extension threshold value ( $T_e$ ) - are pre-determined based on platoon arrival characteristics at the intersection.

### 5.3.8 *TSP Call manager*

The behavior of this module depends upon the status of the priority phase during the platoon-priority start time. If the priority phase status is green during the platoon-priority start time, the module informs the Hold Call Manager to hold the priority phase green until the platoon-priority end time. If the priority phase status is not green, the module sends a continuous pulsating signal to the controller activating Transit-Signal Priority (TSP) sequence. As soon as the priority phase turns green, the TSP call is dropped and Hold Call Manager is informed to hold the green for the remaining platoon-priority interval.

### 5.3.9 *Controller Manipulation*

#### *Platoon-Priority*

For the Platoon-Priority treatment the system requires an easy and flexible way to over-ride normal controller operations. When a platoon is detected on the priority phase approach, the signal status could be in green or non-green portion of the cycle. If the signal status is not green,

the system needs to safely terminate the phase that is currently being served and skip all other un-served phases and switch to the priority phase by the time the first vehicle in the platoon arrives at stop bar. If there is already a queue, it needs to be discharged before the platoon joins the queue avoiding unnecessary stops. There are several ways to implement this. One way is to force-off the phase that is being served and issue phase omit calls to all the other un-served non-priority phases, and hold the priority phase for the required period. But this method results in more complex algorithm and hardware architecture. The simplest way is to issue a low-priority preemption call (bus preemption) for the required interval period so that the platoon gets served. When the priority call is dropped, the controller resumes normal signal control operation in the phase that was held by the bus preemptor. If the priority-phase has not timed its minimum green time by the time the priority sequence was activated, the controller resumes normal operation by timing its minimum green. And also the controller does not consider the priority green time served while counting down the max timer. This results in sluggish performance. And also, the AWF system needs to hold the AWF phases for variable period in order to provide dilemma-zone protection when required. Since the priority phases generally are also the AWF phases, issuing bus-preemptor calls and phase-hold calls at the same time results in complex signal operation. It becomes very difficult to predict the controller operations and complicates the end of green predictor algorithm. Therefore to overcome these problems and to efficiently achieve the system objectives, the controller is manipulated using a combination of bus-preemptor calls and phase holds. When a platoon is detected on the priority phase approach, the signal status could be in green or non-green portion of the cycle. If the signal status is not green, the system needs to safely terminate the phase that is currently being served, and skip all other un-served phases, and switch to the priority phase by the time the first vehicle in the platoon arrives at stop bar. If there is already a queue, it needs to be discharged before the platoon joins the queue. To achieve this, the controller is overridden using a combination of TSP calls and phase holds. The controller manipulation depends on the status of priority phase during the priority start time. The signal can be in either one of these two states:

- Green
- Non-green (yellow or red)

The controller manipulation for these two cases is described below:

**Green:** If the signal status is already green, a phase hold is issued from the time a platoon is detected until the platoon-priority interval end time. This ensures that the phase does not gap out until all the vehicles in the platoon pass through the intersection. This phase hold is subject to the maximum green timer of that particular phase and is not applied past the max timer expiration. This restriction is placed to avoid higher delays on conflicting approaches.

**Non-green:** In this case, the system issues a TSP call so that the phase being served is terminated and priority phase is served by omitting all other un-served phases (TSP settings are set accordingly). As soon as the current serving phase enters into its yellow clearance interval, the TSP call is dropped and a phase hold is applied until the priority interval end time. This process is called early green. If the priority-phase receives an early green, the algorithm is locked at the end of priority phase until all the non-priority phases that have calls are served once. This

restricts giving back-to-back early greens to the priority phase which incurs unreasonable delays on non-priority phases.

### Dilemma-Zone Protection

The Dilemma-zone protection is provided only when the subject phases are green. Therefore, only the phase hold option is used to over-ride the normal signal control operation. Also, the dilemma-zone protection is not provided to avoid higher delays on minor approaches if the phase max timer expires.

## **5.4 Platoon-Priority System Algorithm**

The PPS algorithm is a two stage algorithm. In the first stage, the algorithm keeps track of vehicle arrivals at the intersection in order to detect a platoon qualified for priority and schedules platoon-priority window; this stage is *platoon identification stage*. Once a qualified platoon is detected, the algorithm jumps to the second stage called *platoon extension stage*. In the platoon extension stage, the algorithm evaluates each additional vehicle following the platoon to determine whether to provide platoon-priority to the vehicle along with the platoon or not. The algorithm uses the following user-defined parameters:

- Minimum platoon size ( $n$ )
- Platoon's cumulative headway threshold value ( $T$ )
- Phase clearance time ( $c$ )
- Advance detector distance from the stop bar ( $D$ )
- Platoon extension threshold value ( $T_e$ )

Figure 5-4 provides the flowchart of the PPS algorithm. Advance detector data acquires The following subsections provide descriptions of the two stages in the algorithm.

### *5.4.1 Platoon Identification Stage*

In real-time, the algorithm keeps track of the last group of  $n$  vehicles that passed over the advance detectors. The algorithm records the vehicle speed, length, and departure time at advance detector for all these vehicles. Using this information and advance detector distance ( $D$ ), the algorithm estimates the arrival times at the stop bar for all the vehicles. The arrival times at

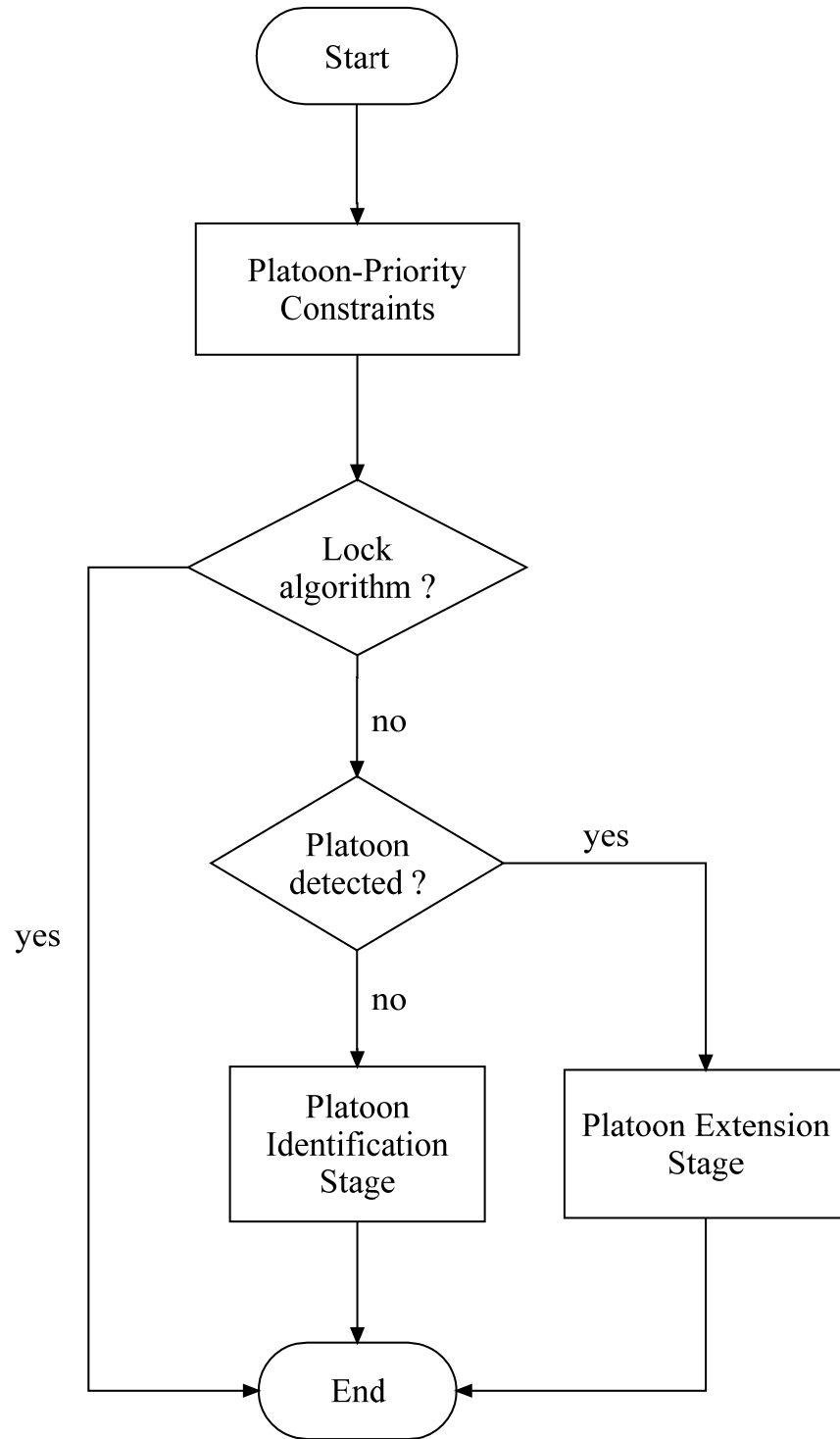

Figure 5-4 Platoon-priority algorithm flowchart

the stop bar are estimated by taking in to account the minimum safe headway; i.e., if the arrival time of a vehicle at the stop bar is less than the arrival time of the preceding vehicle in the same lane plus the minimum safe headway, the arrival time is set to the arrival time of the preceding vehicle plus the minimum safe headway. Once these arrival times are estimated, the first and last vehicles of the group of  $n$  vehicles at the stop bar can be readily determined. Then the difference between the arrival times of the first and last vehicle gives the cumulative headway ( $t_c$ ) of the vehicle group. If this cumulative headway ( $t_c$ ) is less than the user-defined threshold value ( $T$ ), the platoon qualifies for priority treatment and the algorithm schedules platoon-priority time window with start time and end time. While the platoon-priority end time is the arrival time of the last vehicle in the platoon at the stop bar, the start time is a bit complex. In order to prevent any disruption to platoon progression, the phase on priority approach should be green by the time the lead vehicle in the platoon approaches the intersection. Therefore, any conflicting phase should be terminated safely and the signal should jump to priority phase. In addition to that the priority phase queue should also be cleared by that time. Hence, the platoon-priority start time is lead vehicle arrival time minus the phase clearance time ( $c$ ) and queue clearance time ( $q_c$ ). Phase clearance time is the time required to safely terminate the phase, which is yellow interval plus all-red interval. Queue clearance time ( $q_c$ ) is dynamic as it depends on queue size at that moment. Queue clearance time is given by the following equation:

$$q_c = \frac{q_t}{\lambda} * 3600$$

Where

$\lambda$  is saturation flow rate,

$q_t$  = Queue size at time  $t$ .

Queue size at any given point of time is estimated using Input-Output flow conservation equation,

$$q_{t+\Delta} = q_t + Input_{t,t+\Delta} - Output_{t,t+\Delta}$$

Where,

$Input_{t,t+\Delta}$  = Number of vehicles joining the queue during time period  $t, t + \Delta$ ,

$Output_{t,t+\Delta}$  = Number of vehicles leaving the queue during time period  $t, t + \Delta$ .

The algorithm assumes that the intersection is not over-saturated i.e. the size is zero at the start of red phase.  $Input_{t,t+\Delta}$  is determined using the estimated arrival times of vehicles at the stop bar.

$Output_{t,t+\Delta}$  depends on signal status and is as follows,

$$Output_{t,t+\Delta} = \begin{cases} \lambda * \Delta & \text{if signal status is green during } t, t + \Delta \\ 0 & \text{otherwise} \end{cases}$$



Once the platoon-priority window is scheduled, the algorithm shifts to *platoon extension stage*.

#### 5.4.2 *Platoon Extension Stage*

During the platoon extension stage, the algorithm evaluates each additional vehicle that is detected after the platoon to determine whether to include it in the platoon-priority window or not. This is determined by comparing the headway between the subject vehicle and the last vehicle of the platoon at the stop bar with the user-defined platoon extension threshold value ( $T_e$ ). If the headway is less than the threshold value, the algorithm extends the initially scheduled platoon-priority end time to accommodate the current vehicle. This process continues until platoon-priority end time or the maximum green time of the priority phase expires.

#### 5.4.3 *Platoon-Priority Constraints*

The following constraints are placed on platoon-priority algorithm:

- If the platoon-priority results in early green for the priority phase, the algorithm is locked from scheduling a platoon-priority at the end of the phase until all the non-priority approach phases are served once.
- Back-to-back platoon-priorities in same phase are given until maximum green time of the priority phase expires. Platoon-priority is not issued if the priority end time goes beyond the maximum green time.

These two constraints prevent the algorithm from giving indefinite number of back-to-back early greens or platoon-priorities which can result in unreasonably high delays on non-priority approaches and sluggish intersection performance.

### 5.5 **Advance Warning Flasher System Algorithm**

This section describes the algorithm of Advance Warning Flasher System (AWFS). The AWFS algorithm uses the advance detector information and signal controller status information in real-time to predict phase gap-outs in future. Similar to estimation of arrival times at stop bar in the PPS algorithm, the AWFS algorithm estimates arrival times of each vehicle at each dilemma zone detector in the vehicle's lane. These are called detector actuation start times. Using vehicle's speed and dilemma-zone detector lengths, detector actuation end times are also estimated. These times give phase detector on and off times in future. How much into the future depends on the location of advance detector. The farther the advance detectors are from the stop bar the more into the future we can look into. With the available future data of phase detector on and off times the algorithm searches for a phase detector off period in future which gives the predicted gap out time. However, whether the phase ends when the phase gaps out depends on the setting simultaneous gap out feature. When this feature is set to on both through phases should gap out simultaneously in order for the phases to end. Following is a detailed description of the algorithm. [Figure 5-5](#) illustrates the flowchart of AWFS algorithm.

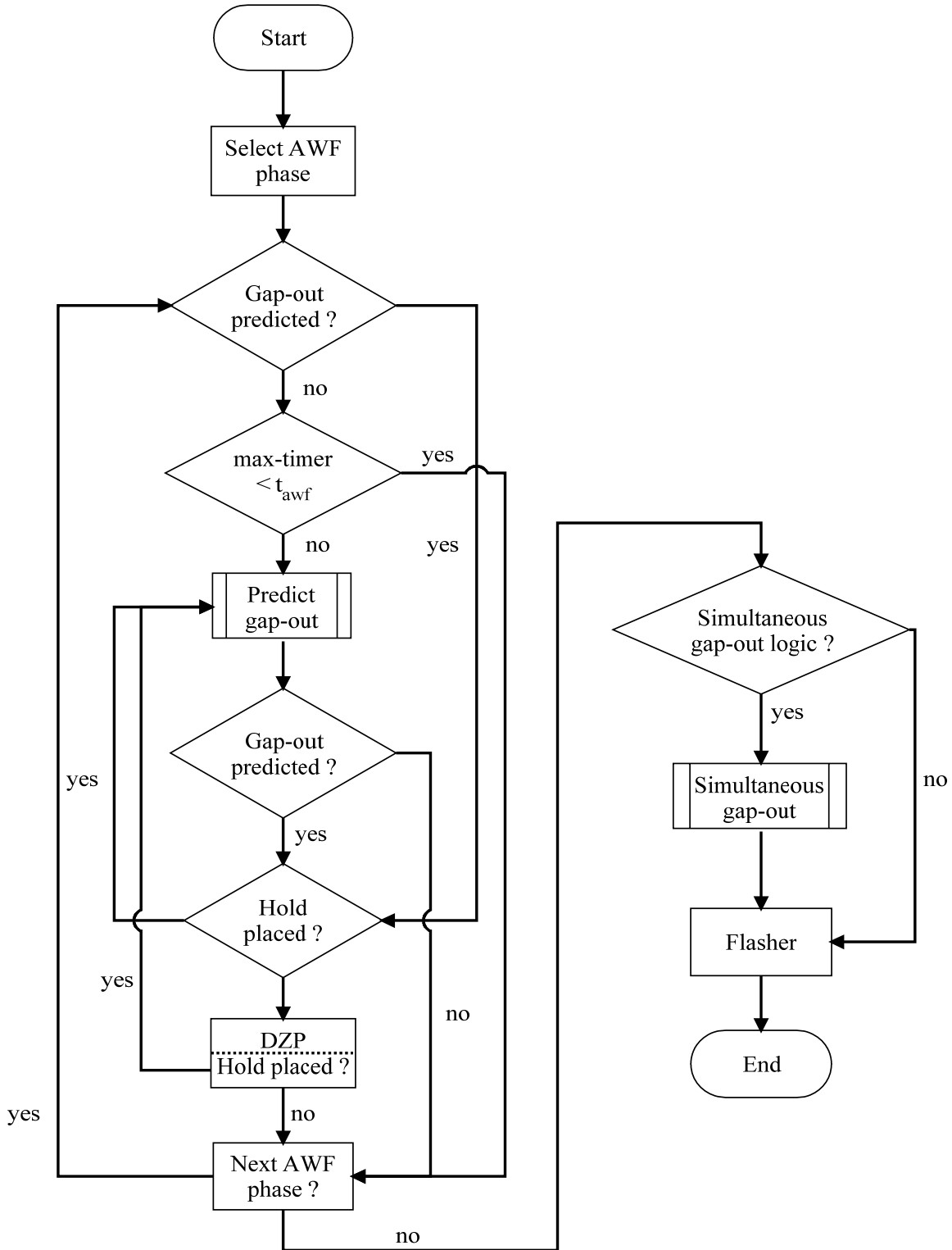

Figure 5-5 AWFS algorithm flowchart

The flow chart consists of two subroutines (*Predict gap-out* and *Simultaneous gap-out*) which are explained in detail later. During each step run, the algorithm checks for each AWF phase whether it already predicted to gap out. If it is already predicted to gap out, then the algorithm jumps to the step of checking whether a hold call is placed. Otherwise, the algorithm first checks if the maximum green time countdown timer is less than the desired advance warning time ( $t_{awf}$ ). If it is less than  $t_{awf}$ , the algorithm predicts a gap out for the phase and jumps to evaluate next AWF phase. Otherwise, the algorithm calls the subroutine *predict gap-out* for the phase.  $t_{awf}$  is a user-defined parameter value, which depends

on approach speed and advance warning flasher location. The recommended values for different speeds and locations are given in MnDOT detector configuration manual (MN MUTCD). For a typical 65 mph approach, the advance warning flashers are located at 850 feet from the intersection. The MnDOT recommended advance warning time for this scenario is 7.5 seconds. The subroutine, *predict gap-out*, predicts if the phase is going to gap out sometime in the future with the available future data. It returns true or false depending on whether the phase gap-out is predicted or not. It also returns the predicted gap out time for the phase. If the gap-out is not predicted, the algorithm jumps to next AWF phase. If the gap out is predicted, the algorithm checks if there is a hold call placed during the predicted gap out time. If there is a hold call placed, the algorithm goes back to call the subroutine, *predict gap-out*, to predict next gap-out after the current predicted gap-out time. If a gap-out is predicted and a hold call is not placed, the algorithm calls the subroutine Dilemma-Zone Protection (DZP) routine to provide dilemma-zone protection. DZP is provided using hold call if there is a vehicle in dilemma-zone during the predicted phase gap-out time. If a hold call is placed to provide dilemma-zone, the algorithm jumps back to the subroutine *predict gap-out* again. If a hold call is not placed, the algorithm goes to next phase. After both the AWF phases are evaluated for gap-out, the algorithm runs the subroutine, *simultaneous gap-out*, if the simultaneous gap-out feature is used. Even though the gap-outs occur individually, both the phases end at the same time to cross the barrier. Once the phases' end time is predicted, the algorithm begins the *flasher* subroutine. In the *flasher* subroutine, the advance warning flashers are activated only if both the phases are predicted to end.

### 5.5.1 Dilemma-Zone Protection

A dilemma-zone is defined as the area in between which 90% of the motorists do not stop and 90% of the motorists stop (Parsonson, 1974; Zegeer 1977). This is typically the area between 2.5 and 5.5 seconds travel time to the stop bar. The exact area depends on vehicle speed and its type. These dilemma-zone times for cars are estimated from the dilemma-zone areas defined for different speeds in MnDOT manual on detector configuration (MN MUTCD).

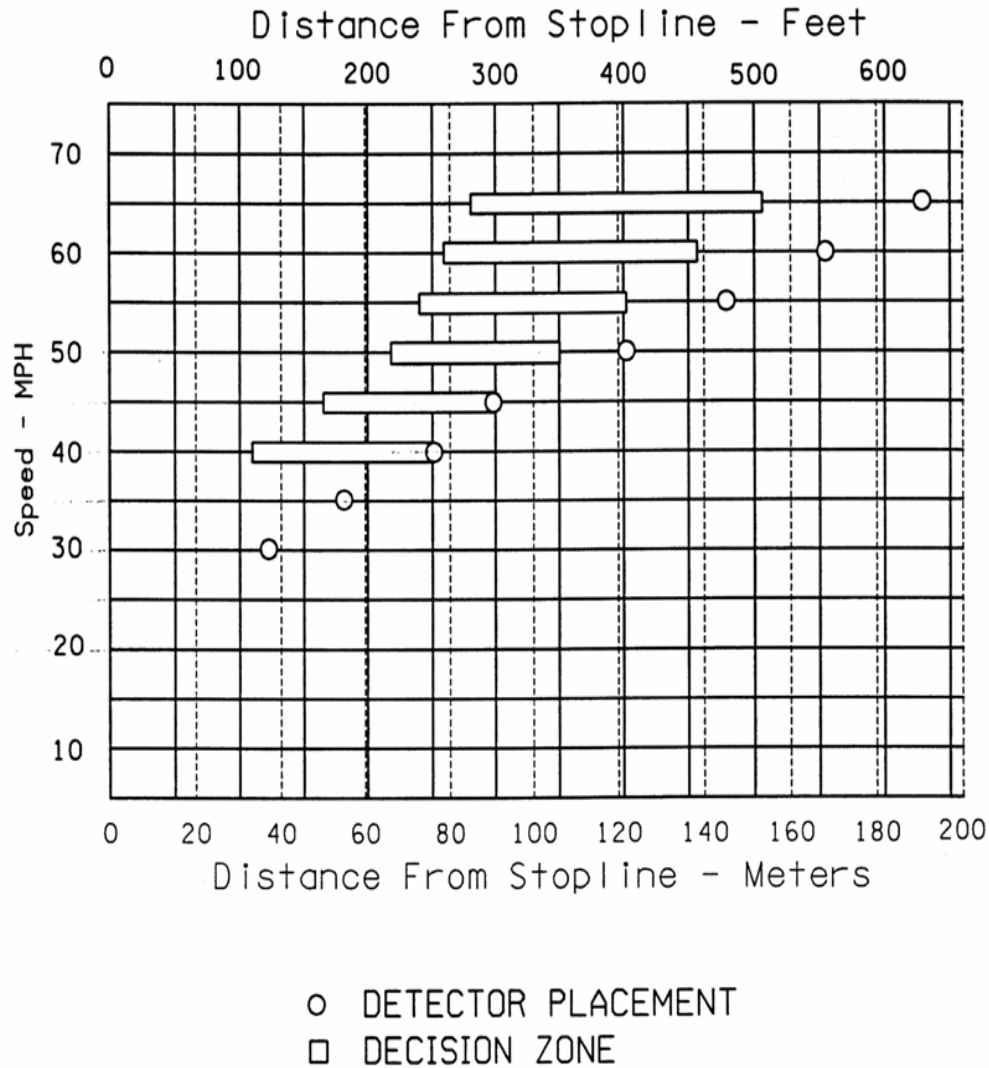

Figure 5-6 MnDOT dilemma zones and detector configuration (MN MUTCD)

The current MnDOT detector configuration layout and defined dilemma zones is shown in [Figure 5-6](#). A research study conducted by Zimmerman (2007) concluded that trucks get benefited by an additional 1.5 seconds dilemma-zone protection over cars as they require longer stopping distance. The dilemma-zone times used for cars and trucks in this research study are shown in [Table 5-1](#). If a vehicle is predicted to be in its dilemma zone during predicted phase end time, the algorithm places a hold on the phase to safely clear the vehicle from its dilemma zone.

Table 5-1 Time Based Dilemma-Zones

Speed (mph)	Car (sec.)		Truck (sec.)	
40	1.9	4.3	1.9	5.8
45	2.4	4.6	2.4	6.1
50	3.0	4.8	3.0	6.3
55	3.0	5.0	3.0	6.5
60	3.0	5.2	3.0	6.7
65	2.9	5.4	2.9	6.9
70	2.9	5.5	2.9	7.0

### 5.5.2 Predict gap-out

As said earlier, the algorithm estimates and maintains data like detector actuation start and end times in future for each dilemma zone detector. The data that becomes obsolete and unnecessary is cleared accordingly to prevent memory overflow. The subroutine uses the following variables during decision making process.

- $t_{dst}^n$  - next detector actuation start time
- $t_{det}^p$  - previous detector actuation end time
- PG - Passage gap set in controller
- TT – Travel time from dilemma zone detector to first dilemma zone detector at 95<sup>th</sup> percentile speed
- $P_i.go$  - Phase  $i$  gap out predicted
- CT – current time

The sequential logic flowchart for this subroutine is shown in [Figure 5-7](#). The algorithm compares difference between the next earliest detector actuation start time ( $t_{dst}^n$ ) and previous detector actuation end time ( $t_{det}^p$ ) with the passage gap (PG) of the phase. If the difference is greater than the passage gap and all the lanes have at least one vehicle in between the first dilemma zone detector and the advance detector, the algorithm declares that the phase will gap-out at time  $t_{det}^p + PG$ . If the difference is less than the passage gap and there are future actuation times remaining to evaluate, the algorithm sets the  $t_{dst}^p, t_{det}^p$  to the following values:

$$t_{dst}^p = t_{dst}^n$$

$$t_{det}^p = t_{det}^n$$

Next, the algorithm sets the  $t_{dst}^n, t_{det}^n$  to the following values,

$$t_{dst}^n = \text{next earliest detector actuation start time after } t_{dst}^p$$

$$t_{det}^n = \text{detector actuation end time corresponding to } t_{dst}^n$$

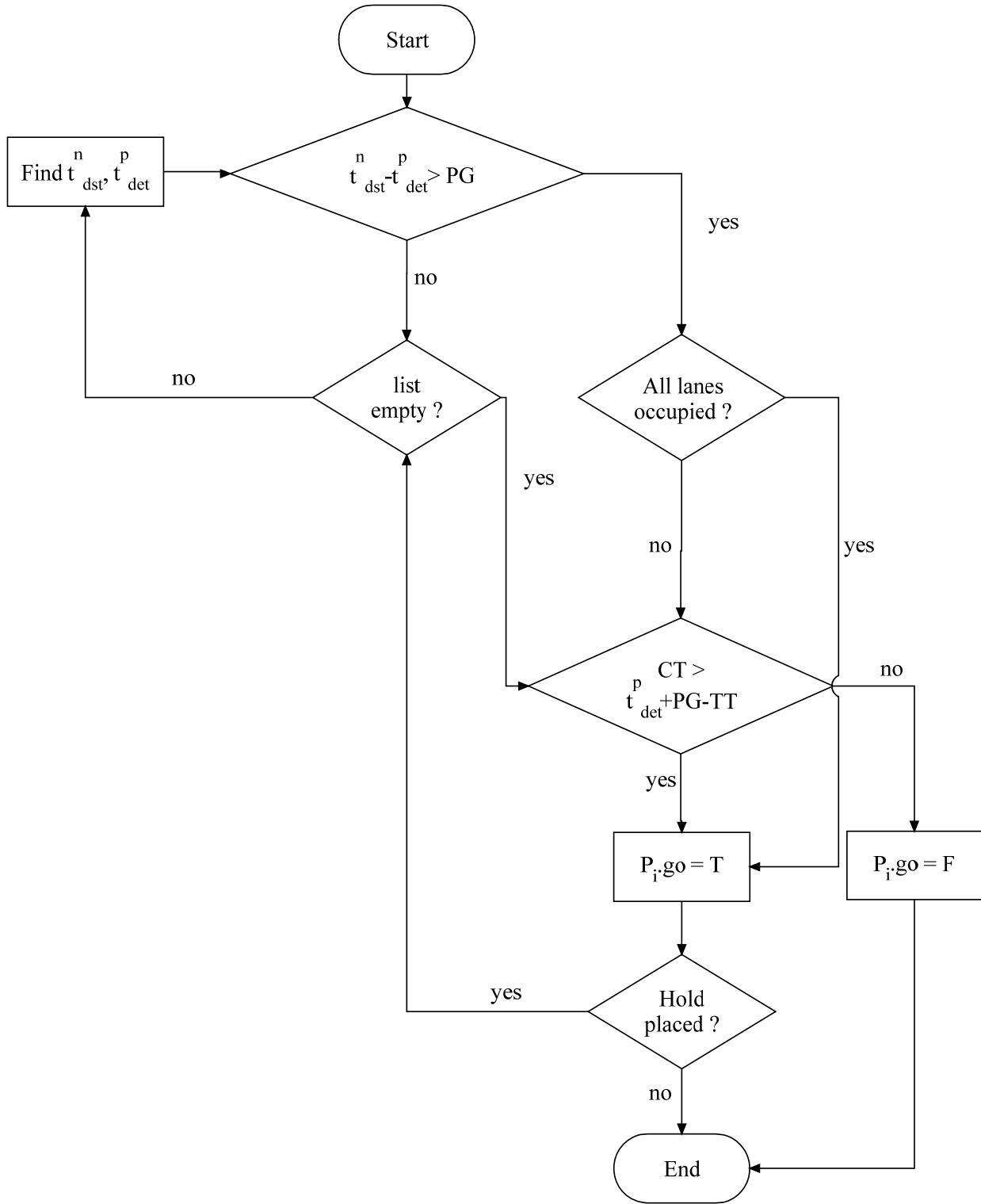

Figure 5-7 Predict gap-out flowchart

If there no more known future detector actuation times remaining to evaluate, the algorithm waits until the time  $t_{det}^p + PG - TT$  before declaring that the phase will gap-out at time  $t_{det}^p + PG$ . The algorithm has no idea of what would be the speed of the next vehicle detected by the advance detectors is going to be. Since  $TT$  is calculated using 95<sup>th</sup> percentile value of the speed distribution on the approach, the probability that a next detected vehicle would make it to the dilemma zone detector before gap-out at time  $t_{det}^p + PG - TT$  is very less. Therefore, the algorithm assumes that the phase will gap-out at time  $t_{det}^p + PG$ . Once the algorithm predicts that the phase will gap-out, the algorithm checks for any hold calls at that time. If there is or is going to be a hold call active during the predicted gap-out time the algorithm goes back to check for next gap-out time.

### 5.5.3 Simultaneous Gap-out Logic

The subroutine uses following variables:

- $P_i.go$  - Phase  $i$  gap out predicted
- $P_i.got$  - Phase  $i$  gap out predicted time
- $TT$  – Travel time from dilemma zone detector to first dilemma zone detector at 95<sup>th</sup> percentile speed
- $P_i.t_{dst}^n$  - Phase  $i$ 's next detector actuation start time

Figure 5-8 illustrates the flowchart diagram for the subroutine. When the simultaneous gap out feature is on, both the phases end only when they both gap out simultaneously or max out. Therefore, if any of the phases is not predicted to gap out, the subroutine ends by setting both the phases' gap out predicted variable to false. If both the phases are predicted to gap out, the algorithm sorts the phases as  $P_1^*, P_2^*$  according to their predicted gap out times.  $P_1^*$  is the phase which has early predicted gap out time and  $P_2^*$  is the phase which has late predicted gap out time. Once the phases are sorted, the algorithm checks if the next detector-actuation start time of phase  $P_1^*$  is greater than predicted gap out time

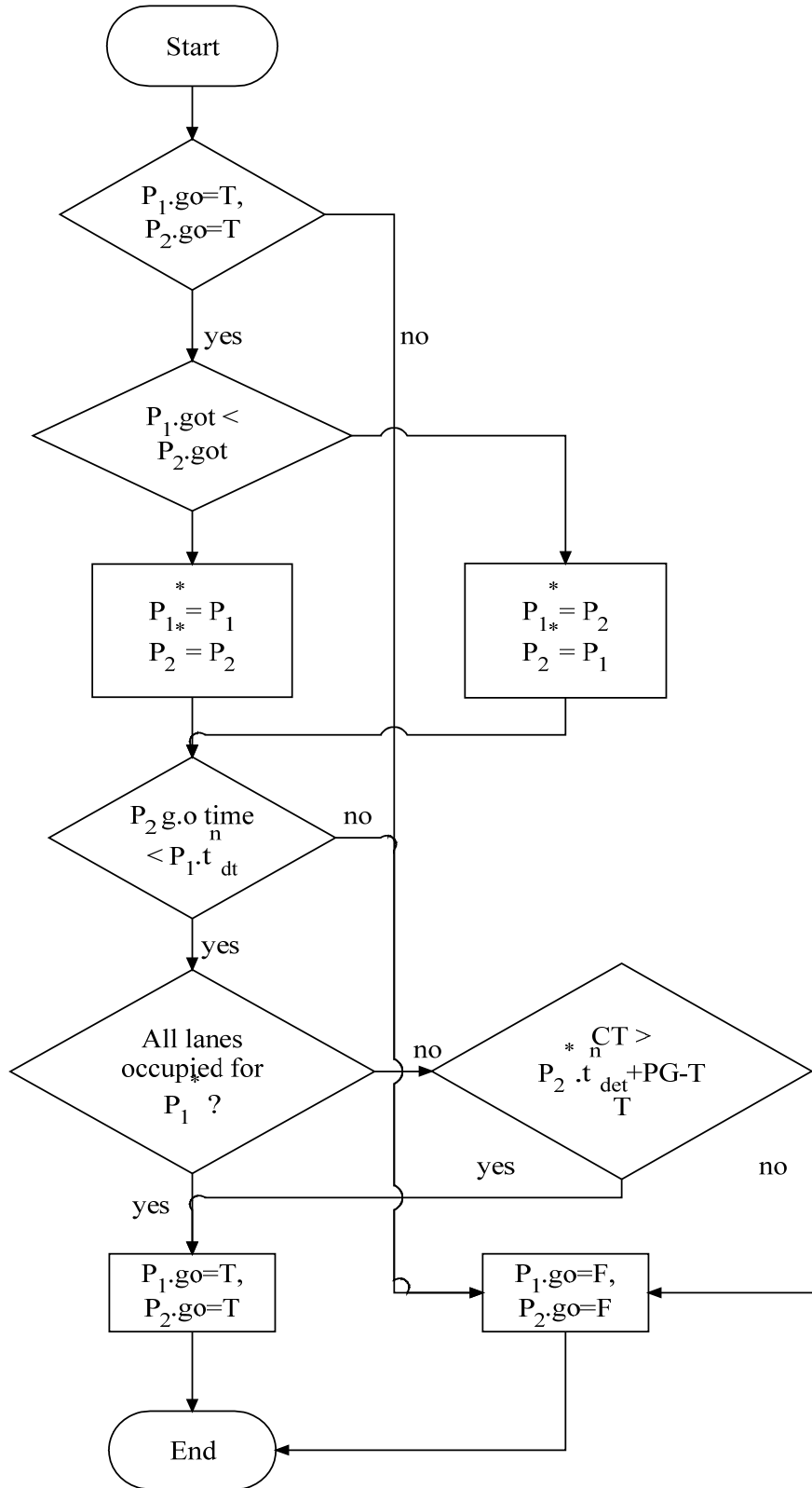

Figure 5-8 Simultaneous gap-out logic flowchart



for phase  $P_2^*$ . If it is true, the algorithm sets both the phases predicted gap out variables to false. Otherwise, if all the lanes of phase  $P_1^*$  have at least one vehicle in between the first dilemma zone detector and advance detector, the algorithm sets both the gap out Boolean variables to true. If all the lanes in between dilemma zone detector and advance detector are not occupied, the algorithm has to wait until time  $P_2^*.got - tt$  before declaring that the phase will end. Therefore, if all the lanes are not occupied and current time is greater than  $P_2^*.got - tt$ , both the gap out variables are set to true. Otherwise, the gap out variable for both the phases is set to false.

#### 5.5.4 AWFS Watch Dog Task

This task uses the following variables:

- $P_i.gtimer$  - Phase  $i$  gap out timer
- $P_i^e.go$  - Phase  $i$  emergency gap out predicted

Figure 5-9 shows the flowchart diagram for this task. The watch dog task keeps track of phase status using ring status bits for each phase i.e., whether the phase status is in extension timing, or in minimum timing. If a phase is serving its minimum green (minimum timing), the algorithm sets the value of  $P_i^e.go$  to false. If a phase is not serving extension timing and minimum timing but a hold is placed, the algorithm sets the value of  $P_i^e.go$  to false. If a phase is not serving extension timing and minimum timing and a hold is not placed, the phase is waiting for the concurrent phase to gap out. In this case, the algorithm sets the value of the waiting phase to true. If the phase is in extension timing, the algorithm watches the gap out timer ( $P_i.gtimer$ ). If the gap out timer counts down to a value less than 0.2 seconds, the algorithm assumes the phase is going to gap out after 0.2 seconds. In this case, the algorithm provides dilemma zone protection if there are any vehicles in dilemma zone by placing a hold on the phase for appropriate amount of time. If a hold is placed, the algorithm sets  $P_i^e.go$  to false, or else to true. This process is

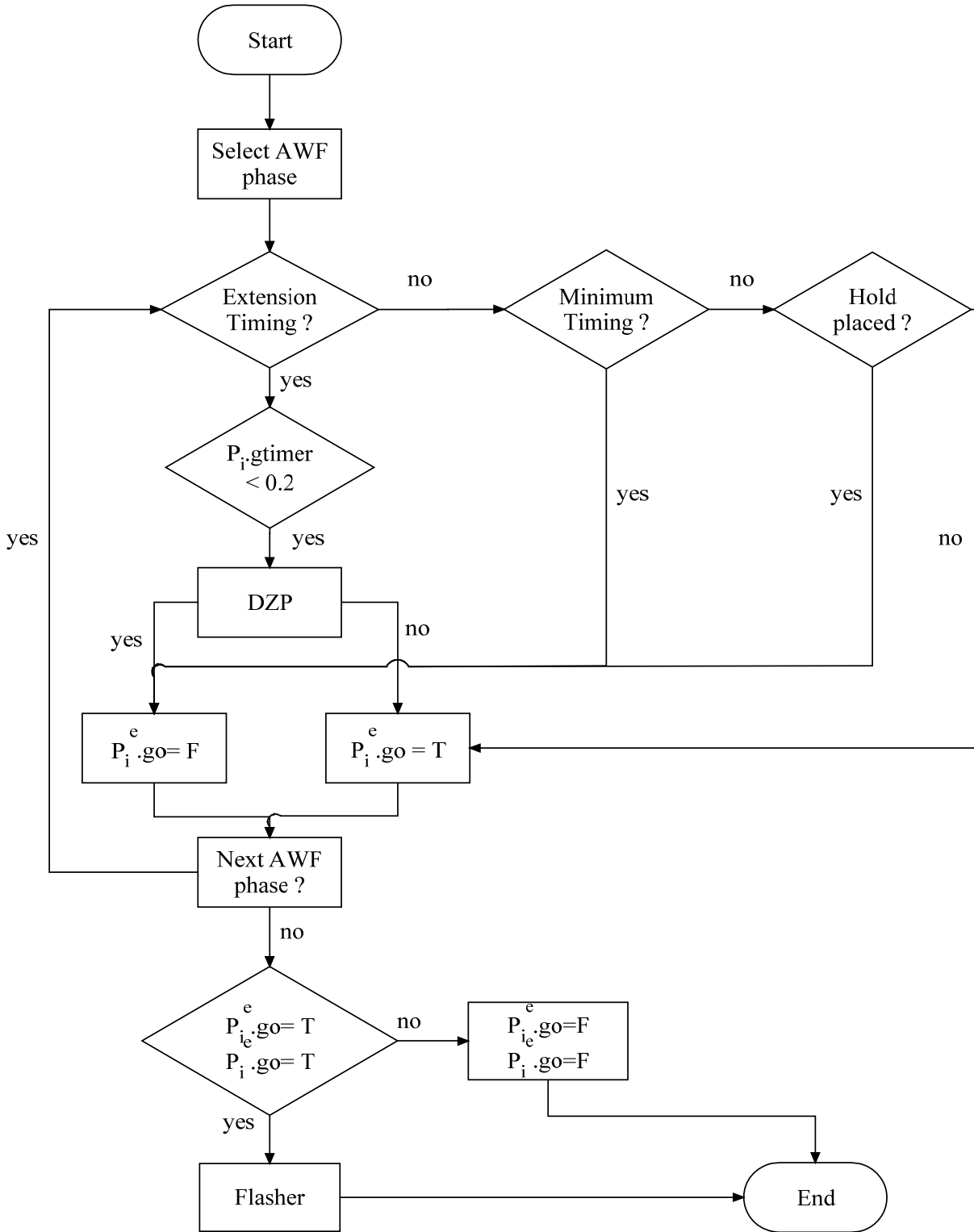

Figure 5-9 Watch dog task flowchart

repeated for each AWF phase. If both the phases are predicted to gap out, the algorithm activates advance warning flashers through Flasher module. If any one of the phase is not predicted to gap out, the algorithm sets both the phase values to false.

## **5.6 Improvements on Previous Systems**

### *5.6.1 Platoon-Priority System*

In the Platoon Identification and Accommodation System developed by TTI (Nadeem et al., 2003), platoons are accommodated through low-preemption call. The system provides users with options to either lock the system for specified time period after a platoon is serviced or to specify conflicting phases that need to be served before another platoon is served. If the algorithm is set to the most restrictive, platoon progression will be affected. On the other hand, the least restrictive settings results in better platoon progression with very high delays on minor approach. In this research study, the algorithm is locked at the end of priority phase from giving another platoon-priority only if it was an early green. The lock is released after serving all the conflicting phases that have demand during priority phase. As long as the priority phase max timer has not expired, back-to-back platoons can be served in the same phase by holding green. This design provides system optimal performance as multiple platoons can be served without building huge delays on minor approach.

### *5.6.2 Advance Warning Flasher System*

AWEGS (Messer et al., 2003) assumes that the intra-detector gap out on dilemma-zone detectors does not occur. However, on Mn/DOT roads, two detector dilemma-zone detector configuration is used. On a typical high speed approach, the two detectors are located fairly far away. As a result, a higher passage gap has to be set in the controller to avoid intra-detector gap outs. This will result in higher Maximum Allowable Headway, which in turn results in frequent max outs and inefficient signal timing. Hence, the passage gap set in the field usually does not cover all the vehicles and intra-detector gap out is possible. The Integrated System is designed in such a way that the actuations at all dilemma zone loop detectors are considered. This helps in predicting all types of gap outs including intra-detector.

In AWEGS, once the gap out is predicted, the advance warning flashers start flashing even though a green hold has been applied to provide dilemma-zone protection. During the hold time, new vehicles might enter on to dilemma-zone detectors qualifying for green extensions. As a result, the advance warning provided can be too long in some cases. On long run, this can have a negative effect, as motorists stop trusting the advance warning flasher beacons. In the developed Integrated System, the algorithm considers holds placed on phases while predicting gap outs. As a result, the system predicts actual gap outs more accurately and reduces cases of unreasonably longer advance warning times.

## 6 CASE STUDY

### 6.1 Cabinet-in the-Loop Architecture

The Integrated System was designed to work in conjunction with a traffic controller in real time. There are not many software-emulators that mimic the behavior of NEMA controllers. Software-emulators lack advanced features such as phase-holds. Therefore, the algorithm was tested in a cabinet-inthe-loop system with an actual traffic controller. [Figure 6-1](#) illustrates the system architecture for cabinet-inthe-loop simulation setup. It primarily consists of three components: PC, cabinet, and controller. In real time, the cabinet sends vehicle detector calls and any controller over-ride input calls (Transit Signal Priority - TSP and Phase Hold inputs) to the controller and, in turn, receives signal status from the controller. Econolite ASC/2S traffic controller installed with TSP software is used for this research study. The PC consists of two sub-components VISSIM simulation software and Integrated System software running on it. At each simulation time step, the vehicle detector calls generated by VISSIM are sent to the cabinet and the current signal status from the cabinet is acquired and updated in VISSIM accordingly. The Integrated System software receives advance detector information such as vehicle type and its speed, from VISSIM at each time step. It also receives phase detector status and signal status from the cabinet at each time step, and, when required, sends controller override input calls to the cabinet. A digital Input/Output card is used to provide communication between the computer and cabinet. A picture showing the Cabinet-in the-Loop hardware equipment used for this study is shown in [Figure 6-2](#).

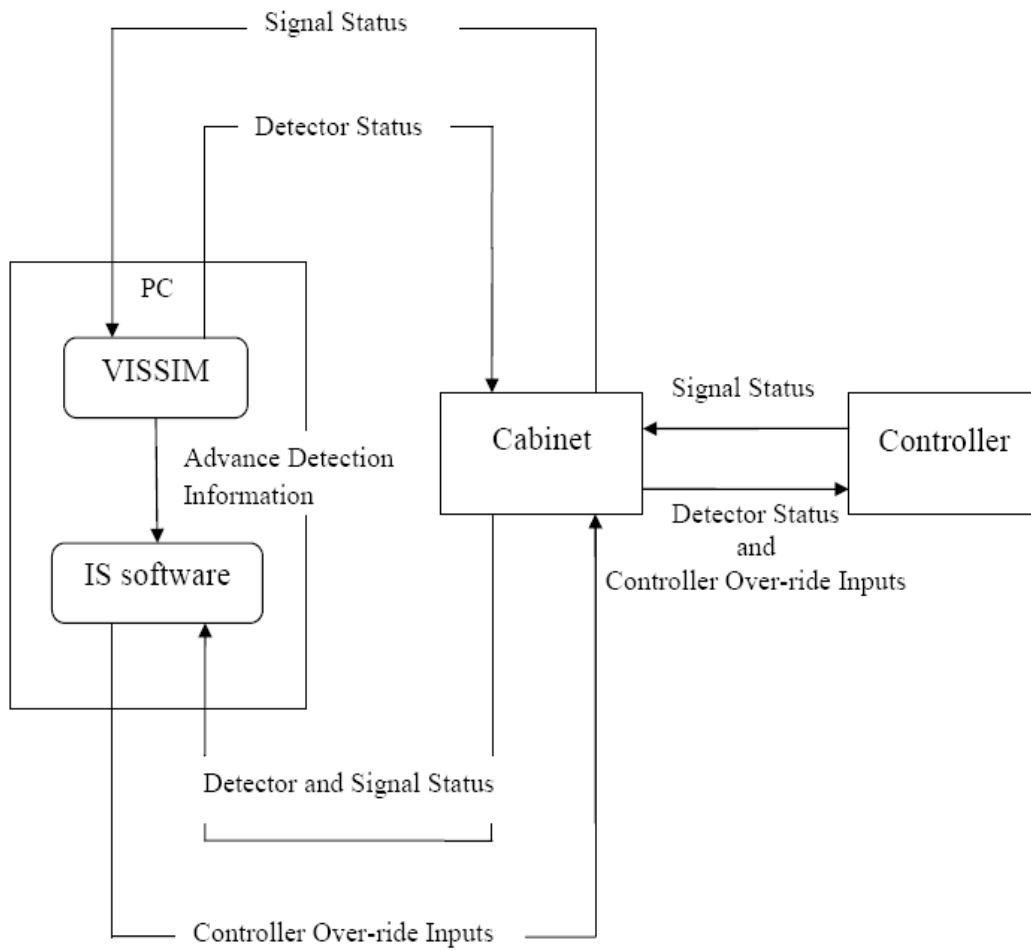

Figure 6-1 Cabinet-in-the-loop architecture

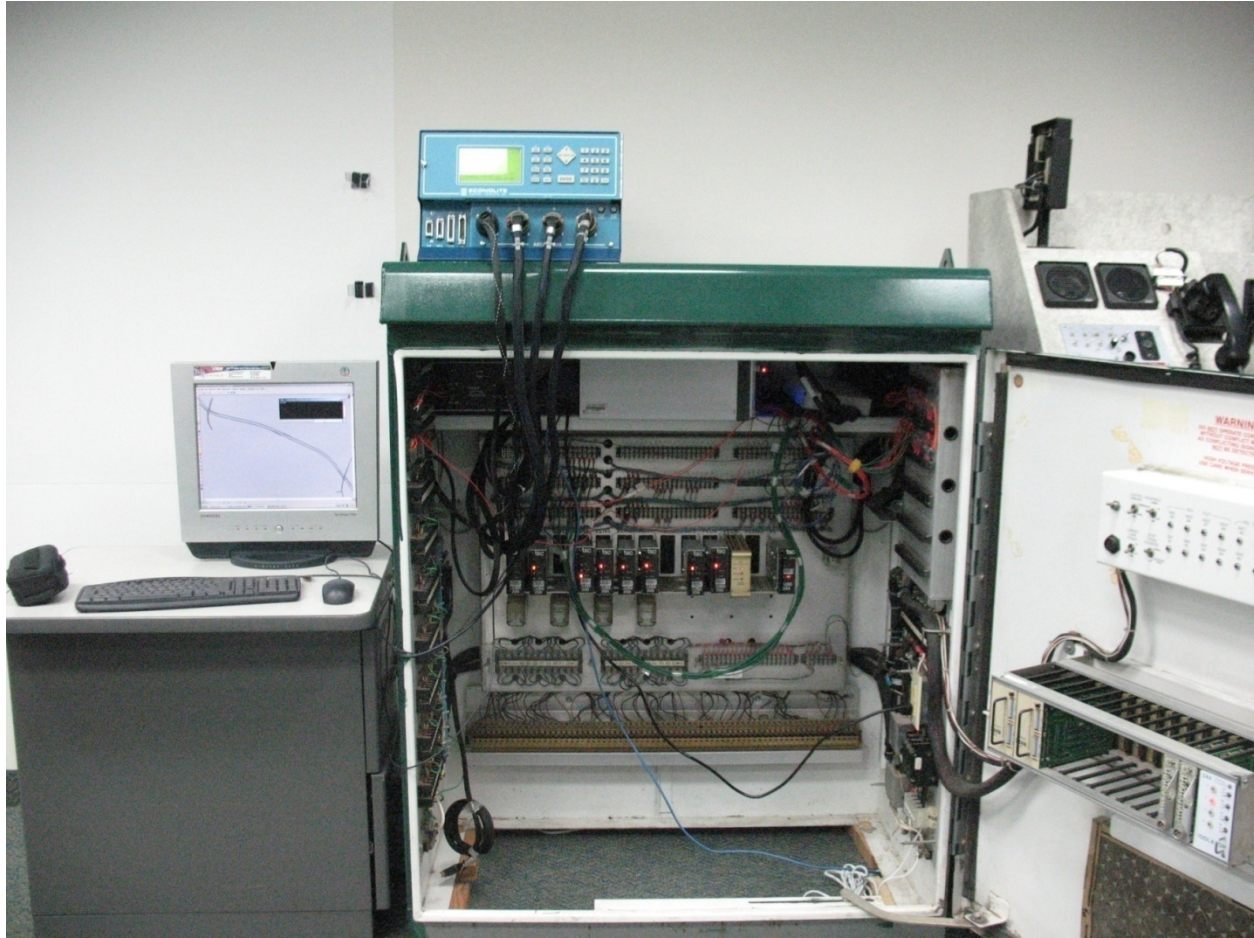

Figure 6-2 Cabinet-in-the-loop equipment

## 6.2 Study Site

The developed Integrated Platoon-Priority and Advance Warning Flasher System was tested in cabinet-in-the-loop architecture for the intersection of Trunk Highway 55 and Argenta Trail in Inver Grove Heights, Minnesota, shown in [Figure 6-3](#). The intersection is a high-speed fully actuated isolated signalized intersection with a major (T. H. 55) and minor approach (Argenta Trail). It is located 1.2 miles southeast from the intersection, Trunk Highway 55 and Trunk Highway 149, and 0.8 miles northwest of the diamond interchange, T. H. 55 and S Robert Trail. T. H. 55 is a two-lane two-way divided highway with a posted speed limit of 65 miles per hour. Argenta Trail is a two-lane, undivided highway with a posted speed limit of 45 miles per hour. The left turn movements on T. H. 55 are protected, where as the left turn movements on Argenta Trail are protected/permissive left turns.

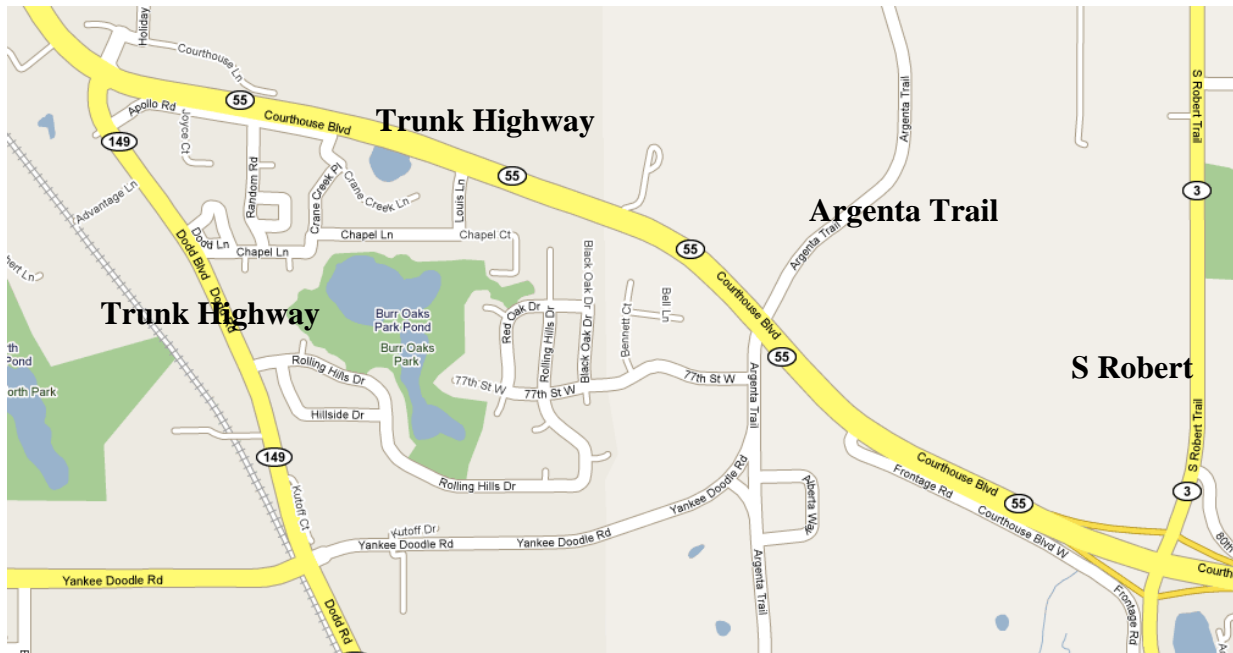

Figure 6-3 Study site layout

The link between T. H. 149 and Argenta Trail does not have any major side streets passing through it. Therefore, the queue of vehicles when released at the upstream intersection, T. H. 55 and 149, during the start-of-green reaches the subject intersection as a partially dispersed platoon. The intersection experiences significant number of these platoons from the upstream intersection during the PM peak period. This makes the intersection ideal for testing Platoon-Priority system. However, platoons are not formed on T. H. 55 westbound approach at the intersection since the approach does not have a signalized intersection nearby.

### 6.3 Data Collection

#### 6.3.1 Volume Data

The traffic volume data for the PM peak hour at the T. H. 55 and Argenta Trail intersection is shown in Figure 6-4. The figures shown here include both car and truck volumes, but the truck volumes were also recorded separately. On the T. H. 55 eastbound approach, 94 percent of the total traffic is through traffic. On the T. H. 55 westbound approach, 34 percent of the total traffic is left turn traffic. Since the T. H. 55 eastbound approach experiences platoons and has higher through traffic volume, the through movement phase on this approach was selected as the priority phase for the PM peak period. The only non-conflicting phase to the priority phase that has higher traffic volume is the T. H. 55 westbound through phase. Therefore, this phase was selected as concurrent priority phase. When the system issues an early green call to serve a platoon on the priority approach, both the priority and concurrent priority phases get early green.

The PM peak hour volume data for the upstream intersection, T. H. 55 and T. H. 149, is shown in [Figure 6-5](#). The inflow and outflow volumes for the eastbound and westbound links of T. H. 55 do not match. Therefore, a dummy sink and a dummy source were added at Louis Lane to balance the inflow and outflow volumes. The AM peak hour data for the intersection of T. H. 55 and Argenta Trail is shown in [Figure 6-6](#). During the AM peak period, the westbound approach on T. H. 55 has very high volume. Researchers initially wanted to test the Platoon-Priority System for this period with the westbound approach being the priority phase. Since the vehicle arrival process on westbound is Poisson process, these simulation test results could provide desired data to evaluate and compare Platoon-Priority System performance for the Poisson arrival process. However, the left turn movements on the westbound approach are so high that the queue spilled back on to the main approach blocking through movements during the initial simulation test runs. This caused errors in predictions by both Platoon-Priority system and Advance Warning Flasher system.

This is due to the following main core assumptions of these two systems:

- Vehicles travel at a constant speed (as measured by the advance detectors) downstream of the advance detectors
- Vehicles maintain the same lane and no overtaking takes place

These assumptions failed terribly when the queue on left turn lane spills back on to the main approach. The predicted arrival times of platoons and gap-out times were way off from the actual values. The Integrated System was primarily developed to operate at intersections where the through movements are predominant and turning movements are very less. Therefore, the idea of testing the system for the AM peak period data was dropped. However, the initial test runs pointed out the limitations of the system and how sensitive the system performance is to the assumptions made.



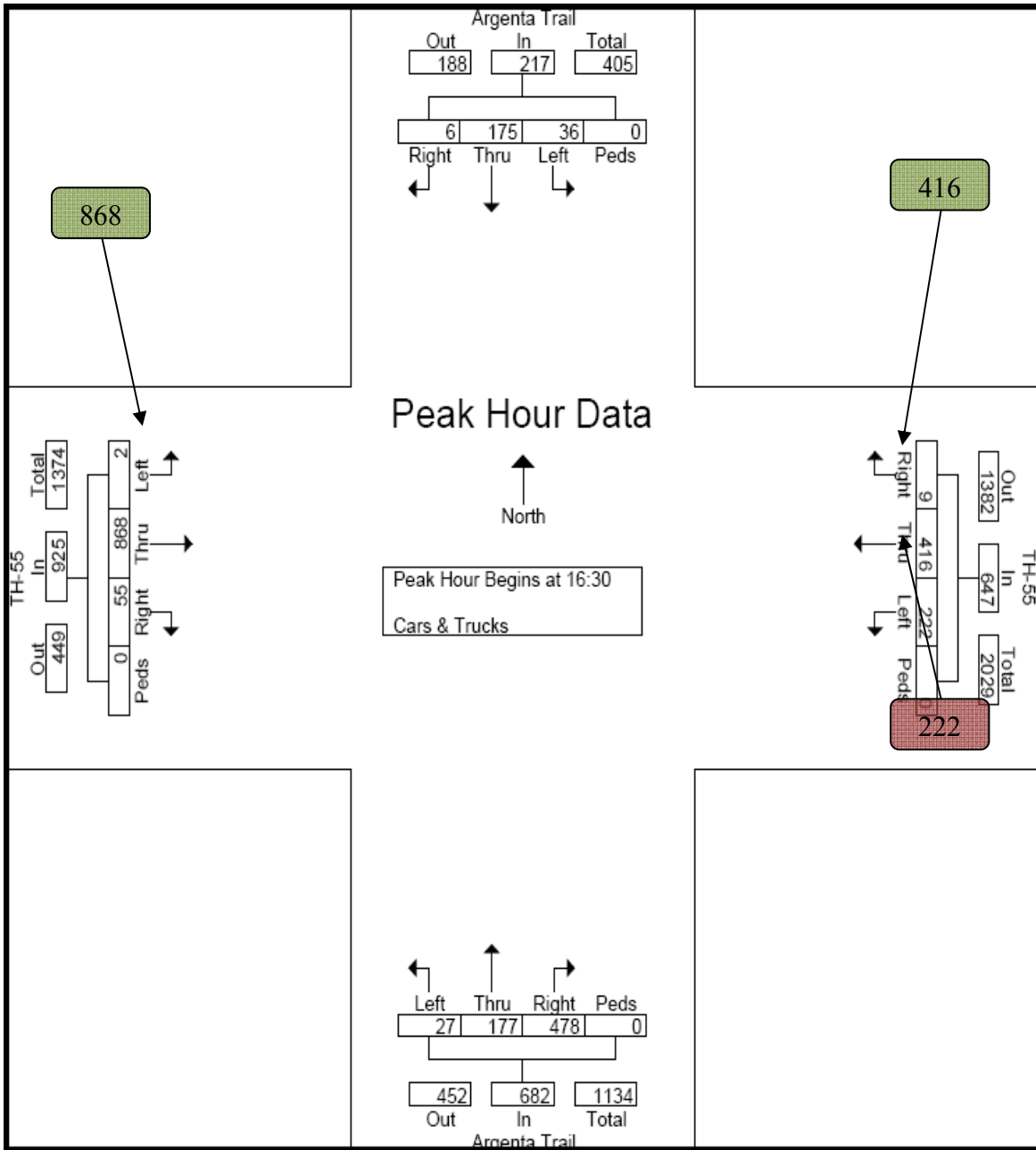

Figure 6-4 PM peak hour data (Argenta Trail intersection)

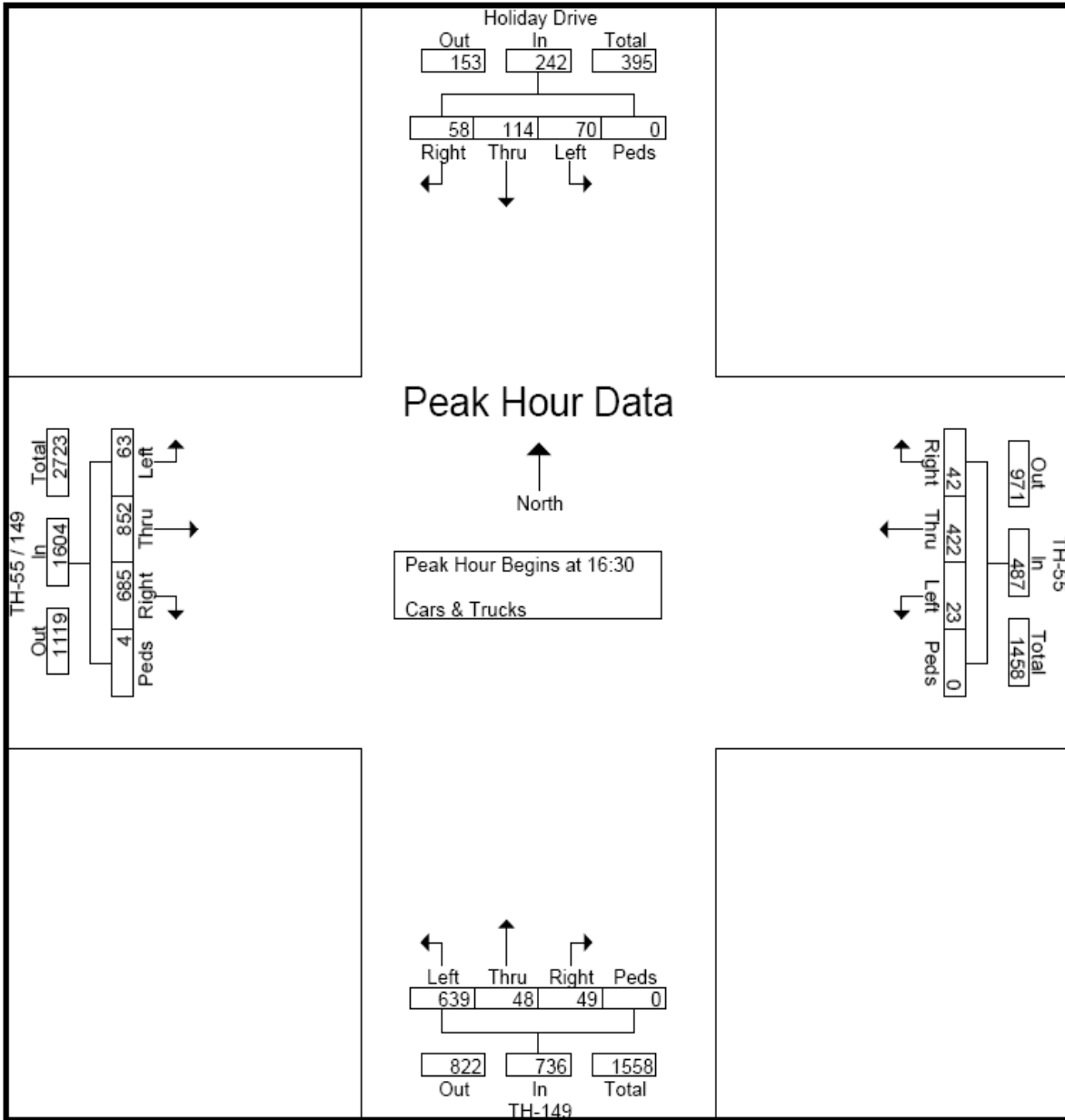

Figure 6-5 PM peak hour data (T. H. 149 intersection)

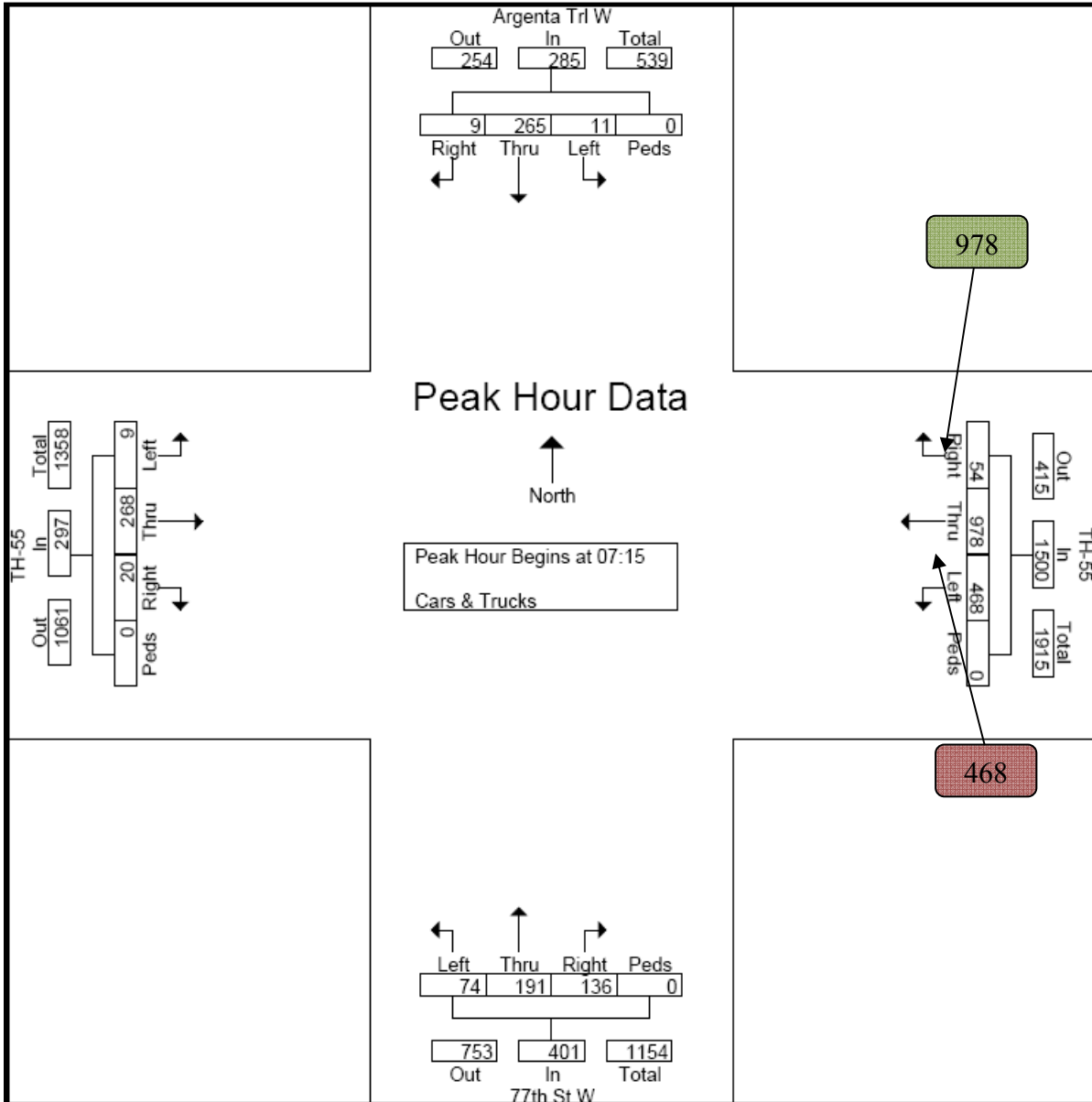

Figure 6-6 AM peak hour data (Argenta Trail intersection)

### 6.3.2 Speed Data

To calibrate the vehicle speeds in simulation model speed distribution data is required. The T. H. 55 and Argenta Trail have different posted speed limits and differ in lane configuration. These two arterials have different speed distributions. Therefore, two sites were selected, one on T. H. 55 and one on Argenta Trail. These data collection sites are shown in [Figure 6-7](#).

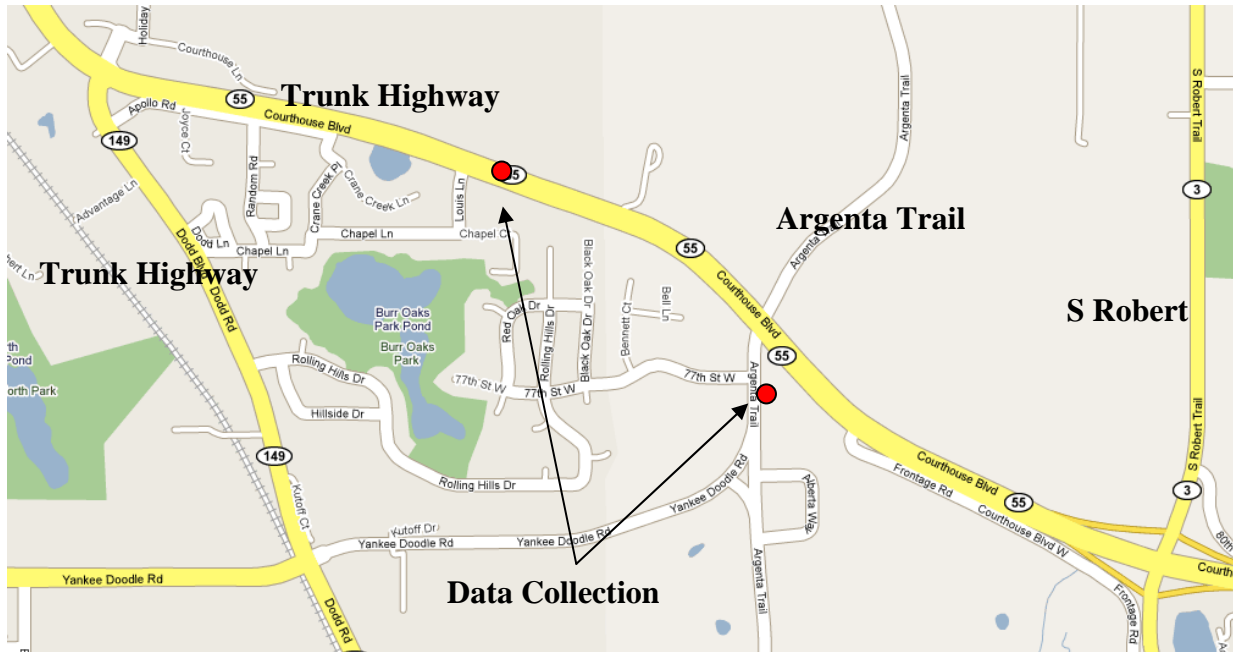

Figure 6-7 Speed data collection sites

The sites selected were sufficiently far away from the intersection such that the measured vehicle speeds were not impacted by the intersection operations. Vehicle speeds were collected using a laser speed gun. On T. H. 55, speed data was collected on eastbound approach. On Argenta Trail, speed data was collected on northbound approach. The descriptive statistics of the speed data collected are presented in [Tables 6-1 and 6-2](#). The histogram and the cumulative distribution plots for these two arterials are shown in [Figures 6-8 and 6-9](#). The 85<sup>th</sup> percentile value for these both arterials is more or less equivalent to the posted speed limit. The free-flow speed distributions in VISSIM simulation model were adjusted to match the speed distributions observed in the field.

Table 6-1 T. H. 55 Speed Data Descriptive Statistics

# of Observations	Mean (mph)	Std. Deviation	Min. (mph)	Max. (mph)
110	40	4.04	26	52

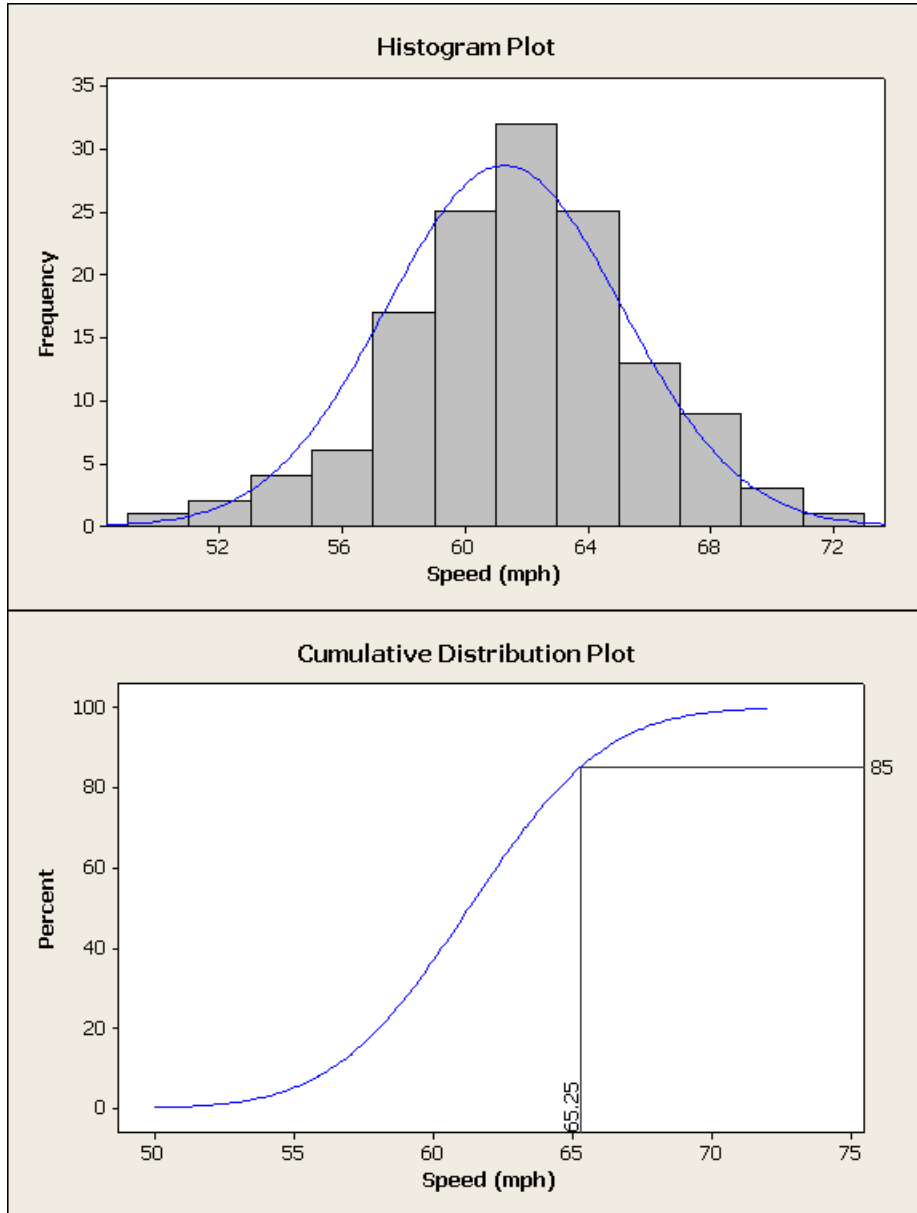

Figure 6-8 T. H. 55 speed data

Table 6-2 Argenta Trail Speed Data Descriptive Statistics

# of Observations	Mean (mph)	Std. Deviation	Min. (mph)	Max. (mph)
110	40	4.04	26	52

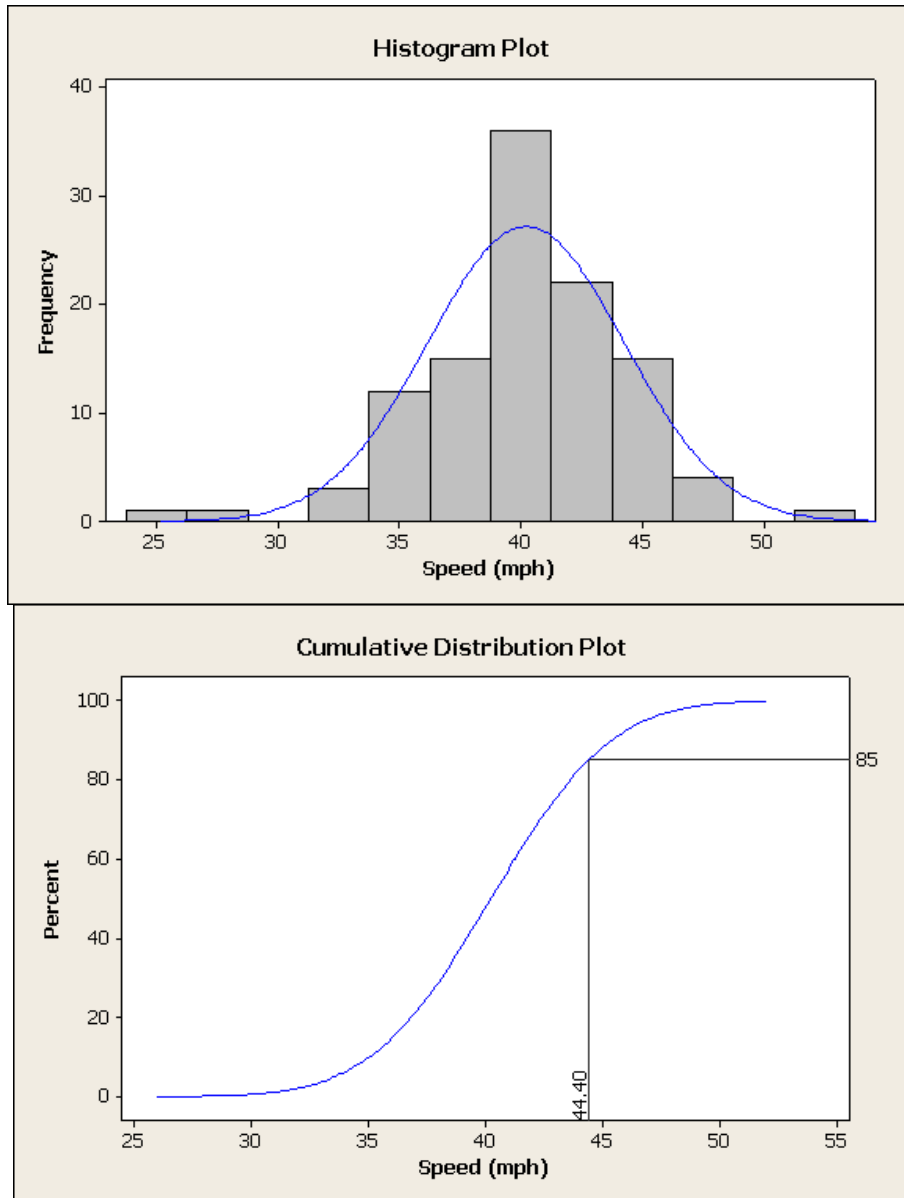

Figure 6-9 Argenta Trail speed data

### 6.3.3 Intersection Layout and Signal Timing Data

The intersection layouts and signal phasing diagrams for the two intersections are shown in [Figures 6-10 and 6-11](#). All the left turn movements are protected except the ones on Argenta Trail which are protected/permissive movements. All the right turn movements are permissive movements. The detector configuration in the simulation model was laid out according to the field configuration. The signal control settings were also set according to the field settings reported by MnDOT. These settings are shown in [Tables 6-3 and 6-4](#).

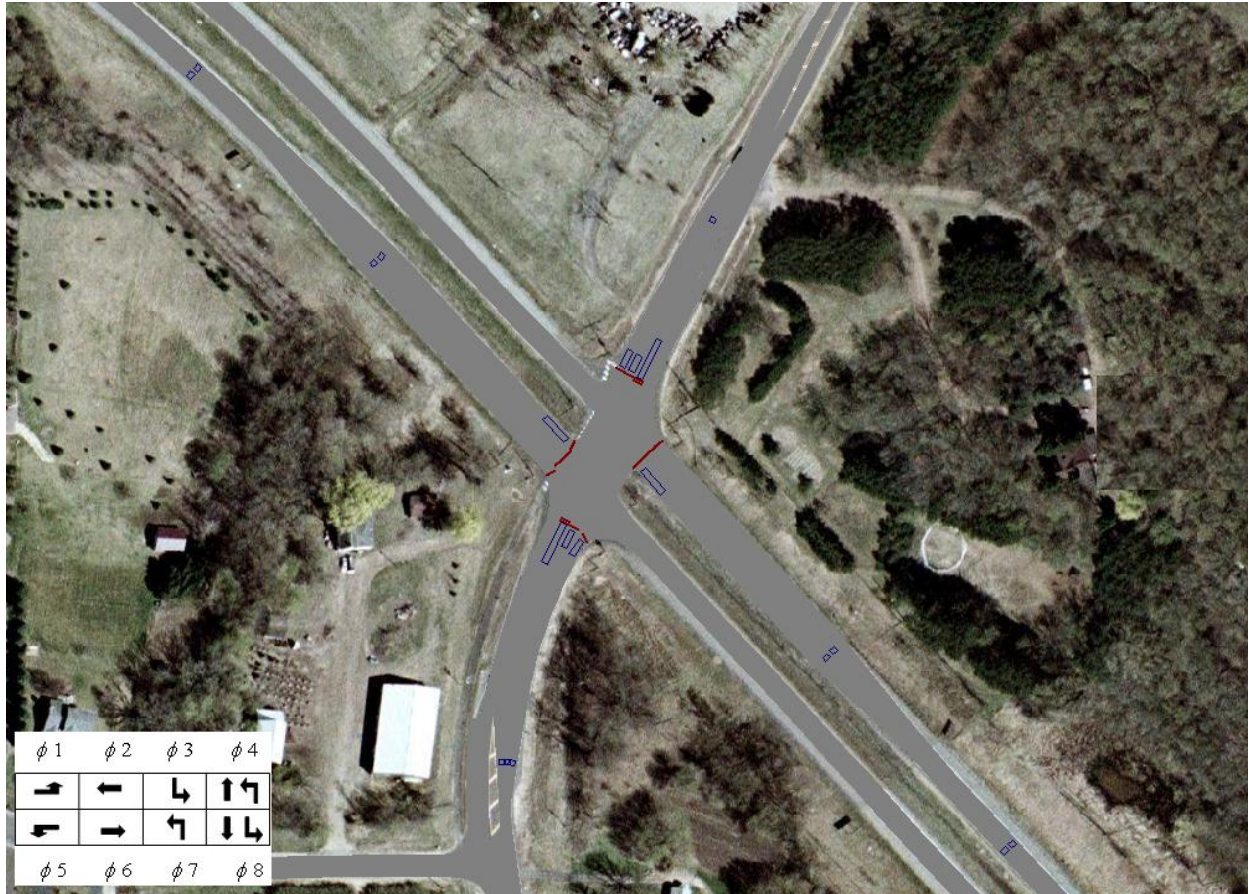

Figure 6-10 Argenta Trail intersection layout

The main street through phases 2 and 6 were set on recall at both intersections so that the controller rests in these two phases whenever there is no demand on other phases. The signal control at T. H. 149 is controlled by Vissim NEMA controller, which is software emulator of actual NEMA controller. The signal control at the Argenta Trail intersection is controlled by actual Econolite ASC/2S traffic controller in cabinet-inthe-loop setting.

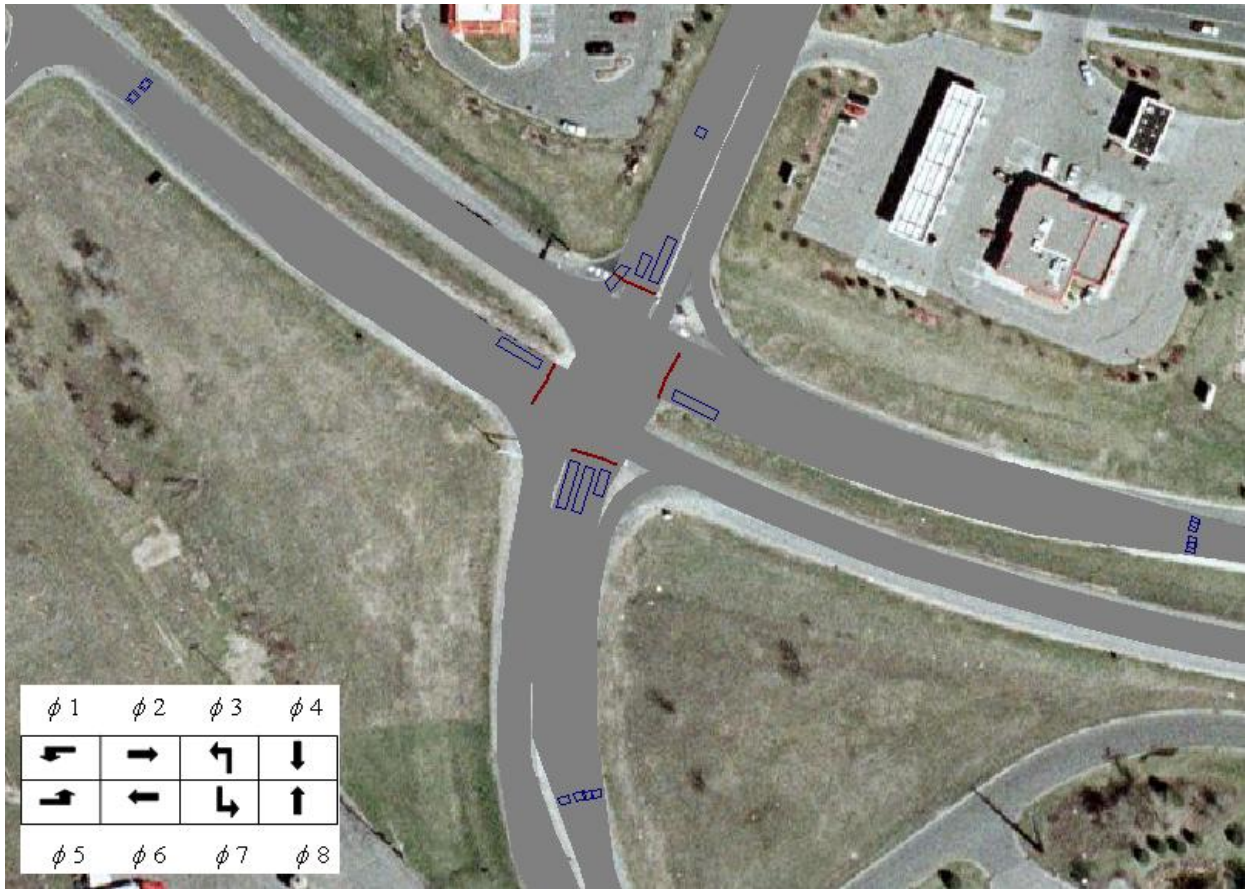

Figure 6-11 T. H. 55 intersection layout



Table 6-3 Signal Timing Data for Argenta Trail intersection

Direction	Phase											
	1	2	3	4	5	6	7	8	9	10	11	12
	EBL	WB55	SBL	NBT	WBL	EB55	NBL	SBT				
Minimum Green	7	20	5	10	7	20	5	10	0	0	0	0
Bike Min Green	0	0	0	0	0	0	0	0	0	0	0	0
Cond Serv Min Grn	0	0	0	0	0	0	0	0	0	0	0	0
Walk	0	0	0	0	0	0	0	24	0	0	0	0
Ped Clearance	7	7	7	7	7	7	7	14	7	7	7	7
Veh Extension	3.0	4.5	3.0	3.0	4.0	4.5	3.0	3.0	0.0	0.0	0.0	0.0
Alt Veh Exten	0.0	0.0	0.0	0.0	0.0	0.0	0.0	0.0	0.0	0.0	0.0	0.0
Max Extension	0	10	0	0	10	10	0	0	0	0	0	0
Max 1	30	90	15	50	45	90	25	50	0	0	0	0
Max 2	0	0	0	0	0	0	0	0	0	0	0	0
Max 3	0	120	0	0	65	120	0	0	0	0	0	0
Det. Fail Max	0	0	0	0	0	0	0	0	0	0	0	0
Yellow Change	3.0	6.0	3.0	4.0	3.0	6.0	3.0	4.0	3.0	3.0	3.0	3.0
Red Clearance	2.0	1.5	2.0	2.0	2.0	1.5	2.0	2.0	1.0	1.0	1.0	1.0
Red Revert	2.0	2.0	2.0	2.0	2.0	2.0	2.0	2.0	2.0	2.0	2.0	2.0
Act. B4 Init	0	0	0	0	0	0	0	0	0	0	0	0
Sec/Actuation	0.0	1.5	0.0	0.0	0.0	1.5	0.0	0.0	0.0	0.0	0.0	0.0
Max Initial	0	45	0	0	0	45	0	0	0	0	0	0
Time B4 Reduction	0	30	0	0	0	30	0	0	0	0	0	0
Cars Waiting	0	0	0	0	0	0	0	0	0	0	0	0
Time To Reduce	0	30	0	0	0	30	0	0	0	0	0	0
Minimum Gap	0.0	3.0	0.0	0.0	0.0	3.0	0.0	0.0	0.0	0.0	0.0	0.0

Table 6-4 Signal Timing Data for T. H. 55 intersection

Direction	Phase											
	1	2	3	4	5	6	7	8	9	10	11	12
	WBLT	EB55	NBL	SBT	EBLT	WB55	SBL	NBT				
Minimum Green	7	20	10	10	7	20	7	10	0	0	0	0
Bike Min Green	0	0	0	0	0	0	0	0	0	0	0	0
Cond Serv Min Grn	0	0	0	0	0	0	0	0	0	0	0	0
Walk	0	7	0	0	0	7	0	7	0	0	0	0
Ped Clearance	7	14	7	7	7	20	7	24	7	7	7	7
Veh Extension	4.0	6.0	3.5	4.0	4.0	6.0	3.5	4.0	0.0	0.0	0.0	0.0
Alt Veh Exten	0.0	0.0	0.0	0.0	0.0	0.0	0.0	0.0	0.0	0.0	0.0	0.0
Max Extension	0	10	0	0	0	10	0	0	0	0	0	0
Max 1	30	70	55	40	30	70	30	35	0	0	0	0
Max 2	0	0	0	0	0	0	0	0	0	0	0	0
Max 3	0	95	0	0	0	95	0	0	0	0	0	0
Det. Fail Max	0	0	0	0	0	0	0	0	0	0	0	0
Yellow Change	3.0	5.0	4.0	3.5	3.0	5.0	3.0	4.0	3.0	3.0	3.0	3.0
Red Clearance	2.0	1.5	2.0	2.0	2.0	1.5	2.0	2.0	0.0	0.0	0.0	0.0
Red Revert	2.0	2.0	2.0	2.0	2.0	2.0	2.0	2.0	2.0	2.0	2.0	2.0
Act. B4 Init	0	8	0	0	0	8	0	0	0	0	0	0
Sec/Actuation	0.0	1.5	0.0	0.0	0.0	1.5	0.0	0.0	0.0	0.0	0.0	0.0
Max Initial	0	35	0	0	0	35	0	0	0	0	0	0
Time B4 Reduction	0	25	0	0	0	25	0	0	0	0	0	0
Cars Waiting	0	0	0	0	0	0	0	0	0	0	0	0
Time To Reduce	0	25	0	0	0	25	0	0	0	0	0	0
Minimum Gap	0.0	4.0	0.0	0.0	0.0	4.0	0.0	0.0	0.0	0.0	0.0	0.0

## 6.4 Simulation Study Results

Several simulation trial runs were conducted to identify optimal parameters for platoon identification. The results indicated minimum platoon size of 6, arrival time threshold of 8 seconds, and extension threshold value of 3 seconds for the test site. These values were used for the following simulation tests. To have a deeper understanding about the effects of systems individually, simulation tests were carried out only enabling one system at a time initially. Finally, both the systems were enabled at the same time and tested. These results are discussed in the following sections.

### 6.4.1 Performance Measure: Delay and Stops

#### Platoon-Priority System

To understand the behavior of Platoon-Priority system and evaluate its benefits, simulation tests were carried out with only Platoon-Priority system enabled. The simulation results are shown in [Table 6-5](#). The table shows that the Platoon-Priority system not only decreased delay and stops for the Priority phase, but also for the whole intersection. For the Priority phase, the advance detector at 1000 feet from the intersection produced lowest delay and fewer stops. In general, the platoon-priority system produced 45-50 percent lower delay and 55-60 percent fewer stops for the priority phase. However, for the concurrent priority phase, the lowest delay and fewer stops are found with advance detectors at 1250 feet from the intersection. As expected, the normal signal timing plan produced better performance on non-priority phases. On a whole, advance detectors at 1000 ft. produced the lowest delay of 21.06 sec/veh and lowest percentage of stops of 50 percent. This is 14 percent decrease in delay and 18 percent decrease in stops over normal signal timing plan.

#### Advance Warning Flasher System

Simulation results obtained from the tests done with only Advance Warning System enabled are shown in [Table 6-6](#) against normal signal timing plan and the Trailing Overlap Green. As expected, Trailing Overlap Green system introduced unnecessary delays on non-priority phases without adding any benefits on priority and concurrent priority phases. This resulted in overall increase in delay and stops. The AWF system provides advance warning by predicting gap out instead of holding the green past gap out, and holds green only when dilemma zone protection is needed. As a result, AWF system produced lower delays and fewer stops than Trailing Overlap Green system. However, AWF system too produced slightly higher delays and more stops than the normal signal timing plan. This is expected as AWF system sometimes holds green to provide dilemma-zone protection for few vehicles on major approach inducing delay on several vehicles waiting on minor approach. It was primarily designed to provide safety at high speed intersections than efficient operation.

Integrated System

The Integrated System performance results are shown in Table 6-7 against Trailing Overlap Green system. There is a slight increase in overall intersection delay over Platoon-Priority system performance. This additional delay is induced by AWF system, as explained previously. However, the AWF system had little to no effect on number of stops. Although the three advance detector locations provided better performance, advance detector location at 1250 ft. provided the best performance. With the advance detectors at 1250 feet, the delays were reduced by 51 percent and stops were reduced by 59 percent for the Priority phase. While considering overall intersection performance, delay reduced was 19 percent and stops reduced was 21 percent.

Table 6-5 Platoon-Priority System Performance

Phase	Normal		Advance Detector Locations					
	Delay	Stops	1000 ft.		1250 ft.		1500 ft.	
Delay			Stops	Delay	Stops	Delay	Stops	Delay
Priority	23.2	53.7	12.1	21.9	12.6	23.0	12.4	23.8
Concurrent	9.9	27.8	11.1	32.0	9.9	27.8	10.4	30.0
Non-Priority	32.1	82.4	33.3	83.7	33.3	84.7	35.7	86.9
Total	24.6	61.3	21.1	50.4	21.2	50.9	22.1	52.1

Delay (s/veh)    Stops (%)

Table 6-6 Advance Warning System Performance

Phase	Normal		Trailing		Advance Detector Locations					
	Delay	Stops	Overlap		1000 ft.		1250 ft.		1500 ft.	
Delay			Stops	Delay	Stops	Delay	Stops	Delay	Stops	Delay
Priority	23.2	53.7	23.8	50.7	21.9	48.9	21.9	46.8	20.9	49.3
Concurrent	9.9	27.8	11.3	31.0	9.6	27.9	10.4	28.8	9.9	28.8
Non-Priority	32.1	82.4	35.7	87.3	33.4	83.0	32.9	84.5	32.4	83.7
Total	24.6	61.3	26.6	62.8	24.8	60.2	24.8	60.4	23.9	60.5

Delay (s/veh)    Stops (%)

Table 6-7 Integrated System Performance

Phase	Trailing		Advance Detector Locations					
	Overlap		1000 ft.		1250 ft.		1500 ft.	
Delay	Stops	Delay	Stops	Delay	Stops	Delay	Stops	
Priority	23.8	50.7	12.4	23.8	11.7	20.9	11.7	20.2
Concurrent	11.3	31.0	9.6	27.0	9.9	28.3	10.4	30.1
Non-Priority	35.7	87.3	35.3	85.2	35.3	85.7	36.2	85.4
Total	26.6	62.8	21.8	50.8	21.6	50.2	22.3	50.6

Delay (s/veh)    Stops (%)

### 6.4.2 Performance Measure: Advance Warning Time

The histograms for advance warning time provided by the Integrated System run for a 10-hour period for different advance detector locations are provided in Figures 6-12, 6-13, 6-14. The results obtained with only AWF system enabled followed similar pattern as of the Integrated System and are shown in Figures 6-15, 6-16, 6-17. The length of advance warning time provided depends on how far the advance detectors are located (the farther they are from first dilemma zone detector, the farther the algorithm can look into future and the longer the algorithm can provide advance warning time). The advance detector location at 1000 ft. provided advance warning time of 3 to 4 seconds majority of times. Similarly, the 1250 feet and 1500 feet locations provided advance warning time of 6 to 7 seconds and 8 to 9 seconds respectively. There were cases when the advance warning time provided was less than 1 second. Ninety percent of these cases were impending gap outs and were predicted by watchdog alarm task. If there were any vehicles in dilemma zone during those gap outs, the algorithm would have extended the green. Advance warning was not necessary in those cases as there weren't any vehicles in dilemma zone. In general, the Mn/DOT recommended advance warning time on a typical high-speed approach of posted speed limit of 65 mph is 7.5 seconds (MN MUTCD). Therefore, for the tested intersection, advance detection at 1250 ft. is suitable for providing recommended advance warning time.

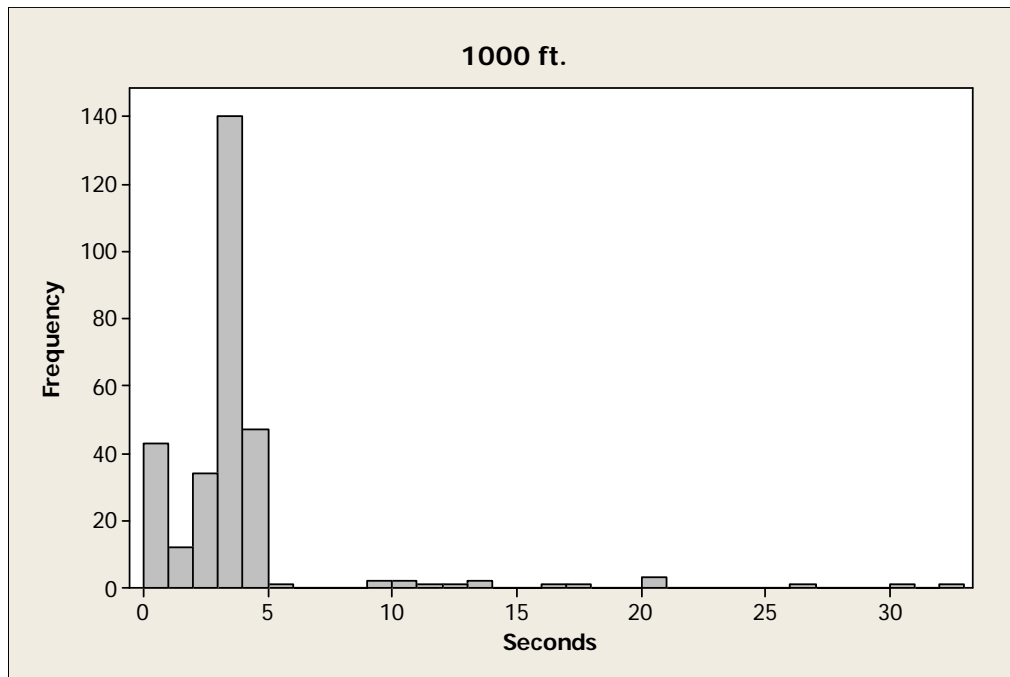

Figure 6-12 Advance warning time histogram (AWF, 1000 ft.)

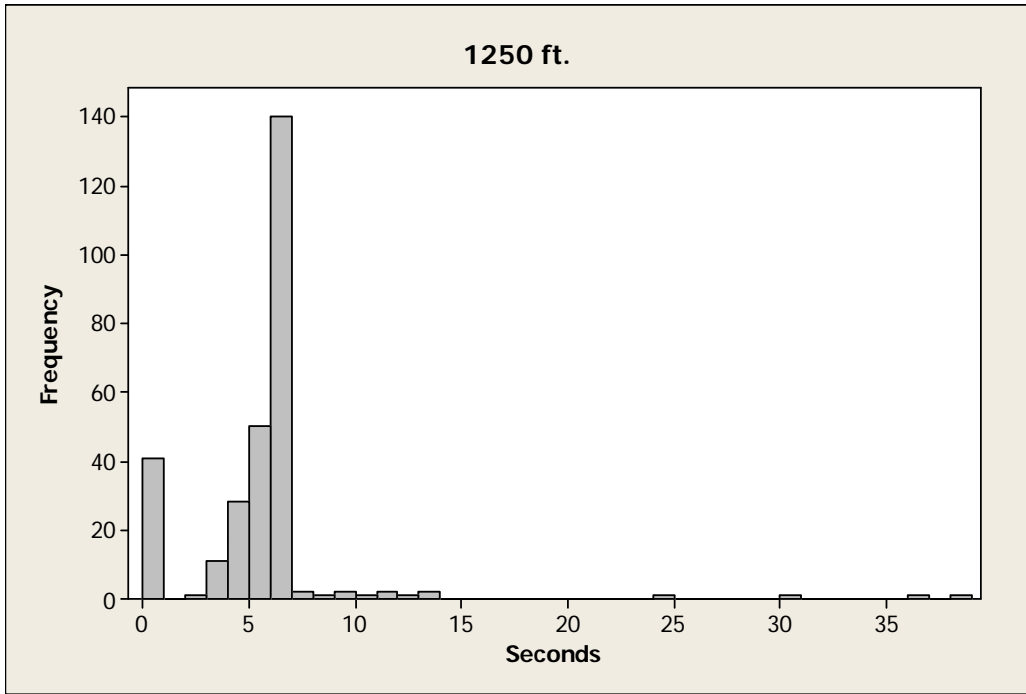

Figure 6-13 Advance warning time histogram (AWF, 1250 ft.)

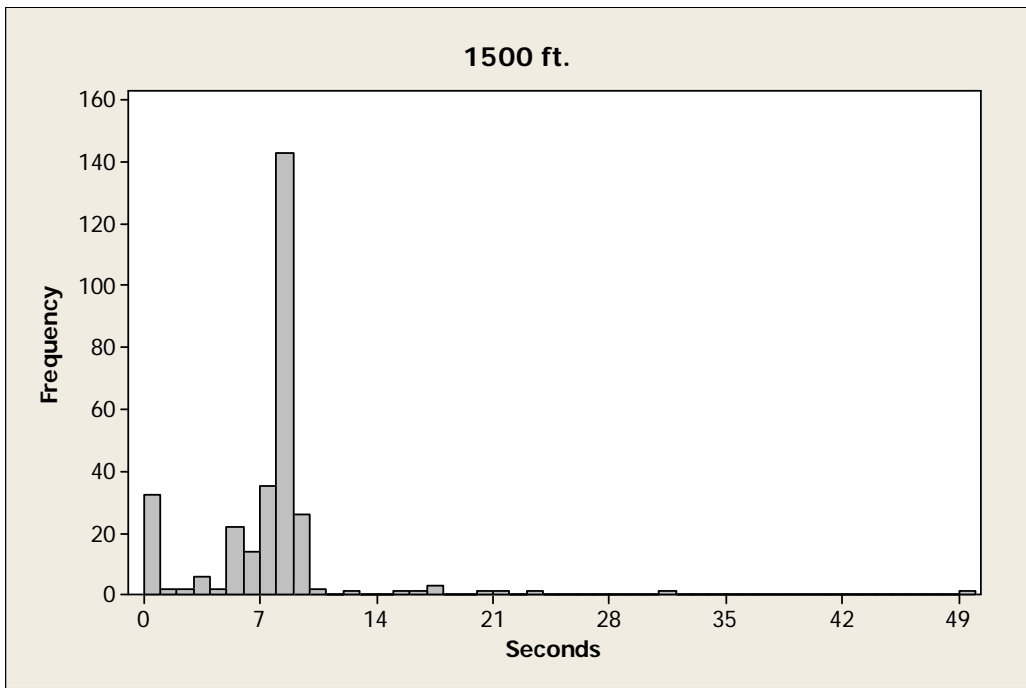

Figure 6-14 Advance warning time histogram (AWF, 1500 ft.)

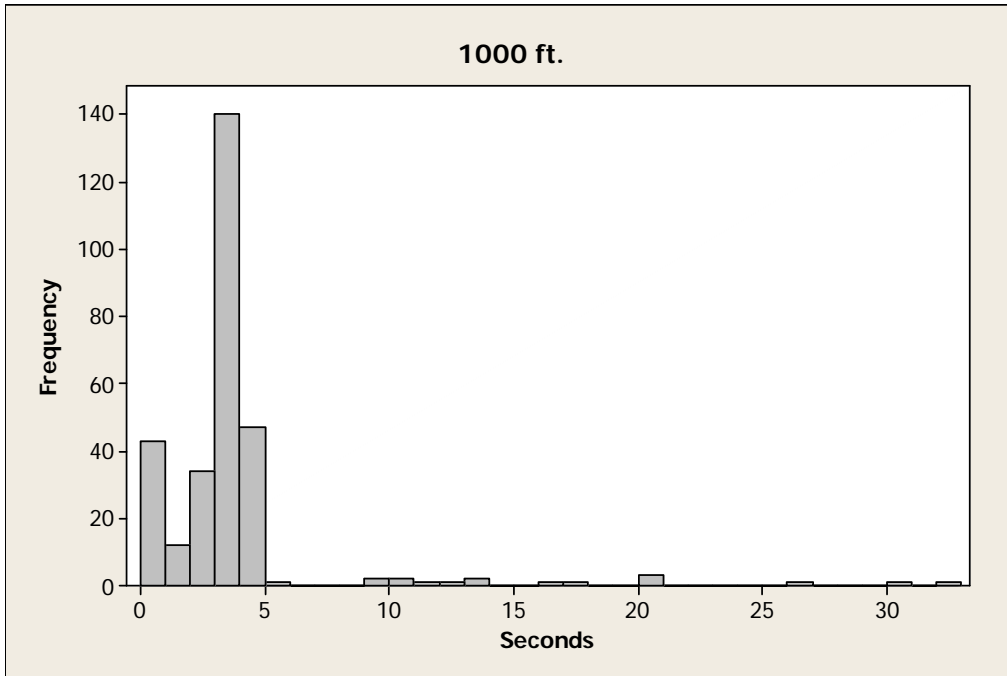

Figure 6-15 Advance warning time histogram (Integrated, 1000 ft.)

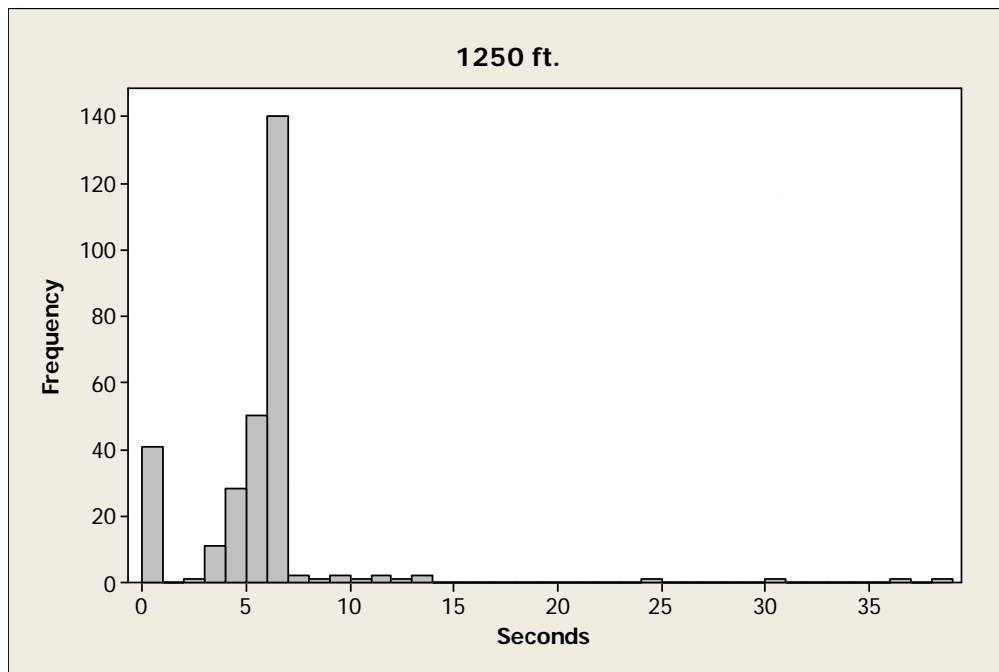

Figure 6-16 Advance warning time histogram (Integrated, 1250 ft.)

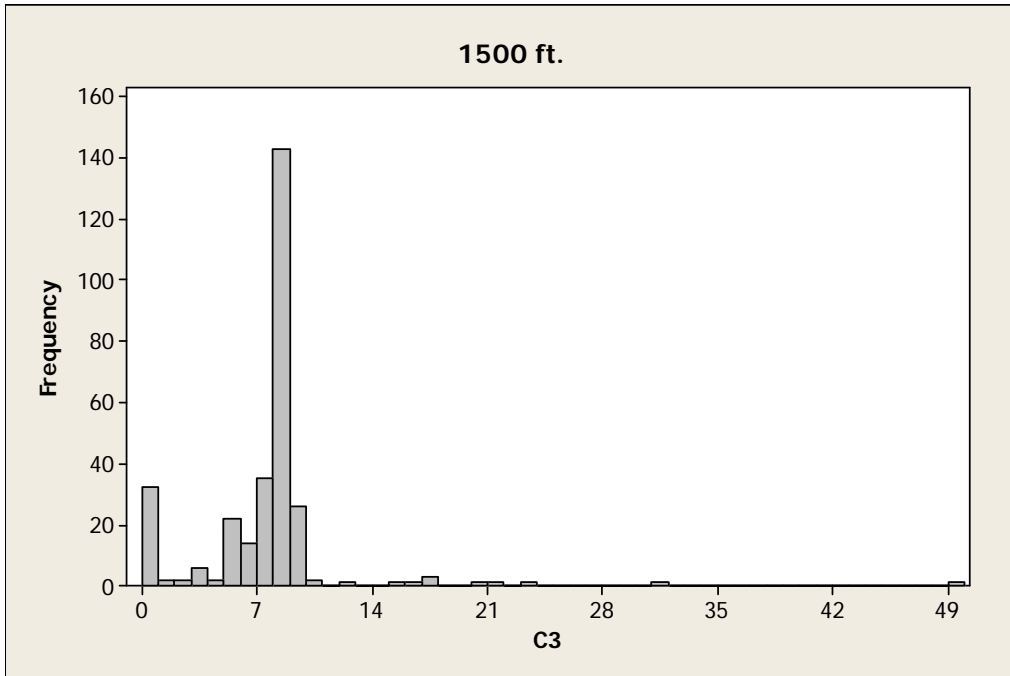

Figure 6-17 Advance warning time histogram (Integrated, 1500 ft.)



# Part IV Concluding Remarks

## 7 CONCLUSION

Vehicle actuated signal control performs poorly at the intersections experiencing platoons. Orthodox advance warning flasher signs, which use trailing overlaps, increase intersection delay and replace existing dilemma-zone protection provided by loop detectors. This research study aimed at developing an integrated signal control system which can provide platoon progression on priority approach and advance warning about end of green on major approaches. The developed system was tested with a real world scenario using cabinet-in-the-loop architecture. The benefits were quantified in terms of delay, stops, and advance warning time provided. The proposed system showed huge potential benefits. Following is a summary of findings for the tested intersection from simulation tests:

- Advance detection at 1250 feet provided optimal performance
- More than 50 percent reduction in delays and stops were found for the approach with platoon arrivals
- Also, overall intersection delay and stops were reduced by 20 percent
- With advance detection at 1250 feet and approach speed of 65 mph, the system was able to provide 6-7 seconds advance warning of end of green in majority of the cases.
- Due to high percentage turning movements there were significant number of cases where the advance warning time provided was less than a second

The proposed system is suitable for rural high-speed intersections which have less turning movements on major approach and experience vehicle platoons on major approach and less traffic volume on minor approach. The current system provides platoon-priority on only one priority approach. Future research direction is to include platoon-priority logic on both major approaches and implement the system on field.

# References

- Chaudhary, N. A., Abbas, M. M., Charara, H., and Parker, R. (2003). *Platoon Identification and Accommodation System for Isolated Traffic Signals on Arterials*. FHWA/TX 05/0-4304-2. Texas Transportation Institute, College Station, TX.
- Chaudhary, N. A., Abbas, M. M., Charara, H., and Parker, R. (2005). *Improved Operation of Traffic Signal Controllers at Isolated Arterial Intersections*. Project Summary Report 0-4304-S. Texas Transportation Institute, College Station, TX.
- El-Reedy, T., and Ashworth, R. (1978). "Platoon Dispersion along a Major Road in Sheffield." *Traffic Engineering and Control*, 19, 186–189.
- Hughes, P. (2000). *Guidelines for the Installation of Advance warning Flashers*. Technical Memorandum, Engineering Services Divisions, Minnesota Department of Transportation, St. Paul, MN.
- Jiang, Y., Li, S., and Shamo, D. E. (2002). *Development of Vehicle Platoon Distribution Models and Simulation of Platoon Movements on Indian Rural Corridors*. FHWA/IN/JTRP-2002/23. Indiana Department of Transportation, Indianapolis, IN.
- Jiang, Y., Li, S., Shamo, D. E. (2006). "A platoon-based traffic signal timing algorithm for major–minor intersection types." *Transportation Research Part B: Methodological*, 40, 543–562.
- Klugman, A., Boje, B., and Belrose, M., (1992). *A Study of the Use and Operation of Advance Warning Flashers at Signalized Intersections*. MN/RC-93/01. Minnesota Department of Transportation, St. Paul, MN.
- Manar, A., and Baass K. G. (1996). "Traffic Platoon Dispersion Modeling on Arterial Streets." *Transportation Research Record*, 1566, 49–53.
- McCoy, P. T., and Pesti, G. (2002). *Advance detection on high-speed signalized intersection approaches*. Publication SPR-PL-1(035) P525. Mid-America Transportation Center, Univ. of Nebraska, Lincoln, NE.
- Messer, C. J., Sunkari S. R., Charara, H. A., and Parker, R. T. (2003). *Development of Advance Warning System for End-of-Green Phase at High Speed Traffic Signal*. FHWA/TX-04/0-4260-4. Texas Transportation Institute, College Station, Texas.
- Michalopoulos, P. G., and Pisharody, V. (1980). "Platoon Dynamics on Signal Controlled Arterials." *Transportation Science*, 14, No. 4, 365–396.
- Mirchandani, P., Zou, N. (2007). "Queuing models for Analysis of Traffic Adaptive Signal Control." *Intelligent Transportation Systems, IEEE Transaction*, 8, 50-59.

Minnesota Department of Transportation. *Minnesota Manual on Uniform Traffic Control Devices*, St. Paul, MN.

Parsonson, P. S. (1974). "Small-Area Detection at Intersection Approaches." *Traffic Engineering*, 8–17.

Pant, P. D., and Xie, Y. (1995). "Comparative Study of Advance Warning Signs at High Speed Signalized Intersection Intersections." *Transportation Research Record*, 1495, 28-35.

Robertson, D. I. (1969). *TRANSYT: A Traffic Network Study Tool*. Report LR253. Transport and Road Research Laboratory, Crowthorne, Berkshire, United Kingdom.

Ross, S. M. (1997). *Introduction to probability models*. Academic Press, 9<sup>th</sup> Edition.

Sayed, T., Vahidi, H., and Rodriguez, F. (1998). "Advance Warning Flashers: Do They Improve Safety?" *Transportation Research Record*. Preprint.

Wasson, J., Abbas, M., Bullock, D., Rhodes, A., and Zhu, C. (1999). *Reconciled platoon Accommodations at Traffic Signals*. FHWA/IN/JTRP-99/1. Indiana Department of Transportation, Indianapolis, IN.

Wang, X. (2007). "Modeling the process of information relay through inter-vehicle communication." *Transportation Research Part B: Methodological*, 41, 684-700.

Yu, L., and Benekohal, R. F. (1997). "Platoon Dispersion and Calibration under Advanced Traffic Control Strategies." *Proceedings of ASCE Conference: Traffic Congestion and Traffic Safety in the 21st Century: Challenges, Innovations, and Opportunities*, Chicago, IL.

Zegeer, C. V. (1977). *Effectiveness of Green-Extension Systems at High-Speed Intersections*. Research Report 472. Bureau of Highways, Kentucky Department of Transportation, Lexington, KY.

Zimmerman K. (2007). "Additional Dilemma Zone Protection for Trucks at High-Speed Signalized Intersections." *Transportation Research Record*, 2009, 82–88.