

ON THE DYNAMICS OF FINE STRUCTURE

By

J.M. Ball

P.J. Holmes

R.D. James

R.L. Pego

and

P.J. Swart

IMA Preprint Series # 727

November 1990

ON THE DYNAMICS OF FINE STRUCTURE

by

J. M. Ball¹, P. J. Holmes², R. D. James³, R. L. Pego⁴, and P. J. Swart²

ABSTRACT

We investigate models for the dynamical behavior of mechanical systems that dissipate energy as time t increases. We focus on models whose underlying potential energy functions do not attain a minimum, possessing minimizing sequences with finer and finer structure that converge weakly to non-minimizing states. In model 1 the evolution is governed by a nonlinear partial differential equation closely related to that of one-dimensional viscoelasticity, the underlying static problem being of mixed type. In model 2 the equation of motion is an integro-partial differential equation that is obtained from that in model 1 by an averaging of the nonlinear term; the corresponding potential energy is nonlocal.

After establishing global existence and uniqueness results, we consider the long time behavior of the systems. We find that the two systems differ dramatically. In model 1, for no solution does the energy tend to its global minimum as $t \rightarrow \infty$. In model 2, however, a large dense set of solutions realize global minimizing sequences; in this case we are able to characterize, asymptotically, how energy escapes to infinity in wavenumber space in a manner which depends upon the smoothness of initial data. We also briefly discuss a third model which shares the stationary solutions of the second but is a gradient dynamical system.

The models were designed to provide insight into the dynamical development of finer and finer microstructure that is observed in certain material phase transformations. They are also of interest as examples of strongly dissipative, infinite-dimensional dynamical systems with infinitely many unstable "modes", the asymptotic fate of solutions exhibiting in the case of model 2 an extreme sensitivity with respect to the initial data.

¹ Department of Mathematics, Heriot-Watt University, Edinburgh EH14 4AS, U.K.

² Department of Theoretical and Applied Mechanics and Center for Applied Mathematics, Cornell University, Ithaca NY 14853

³ Department of Aerospace Engineering and Mechanics, University of Minnesota, Minneapolis MN 55455

⁴ Department of Mathematics, University of Maryland, College Park, MD 20742

1. INTRODUCTION

The purpose of this paper is two-fold: to introduce simple mathematical models which display the dynamical development of “fine structure” and to exhibit strongly dissipative evolution equations which do not possess inertial manifolds or even finite dimensional attracting sets.

In connection with the first question, Ball and James [1987] have suggested that minimizing sequences may play a role in modelling the fine structure sometimes observed in phase transitions. A simple and classical example of a functional which possesses such a minimizing sequence is provided by

$$I(u) = \int_0^\pi \left[\frac{1}{4}(u_x^2 - 1)^2 + \frac{\alpha u^2}{2} \right] dx, \quad (1.1)$$

where $u : [0, \pi] \rightarrow \mathbb{R}$ and $u(0) = u(\pi) = 0$ (cf. Young [1980]). By considering the sequence $u^k(x) = k^{-1}\theta(kx)$, where θ is the π -periodic function with

$$\theta(x) = \begin{cases} x, & 0 \leq x \leq \frac{\pi}{2} \\ \pi - x, & \frac{\pi}{2} \leq x \leq \pi \end{cases}, \quad (1.2)$$

it is easily seen that the infimum of I subject to the boundary conditions (more precisely, in the Sobolev space $W_0^{1,4}(0, \pi)$) is zero. In fact, since $u_x^k = \pm 1$ a.e.,

$$I(u^k) = \frac{\alpha}{2k^2} \int_0^\pi \theta^2(x) dx = \frac{\alpha\pi^3}{24k^2}. \quad (1.3)$$

However, the minimum is not attained, since the conflicting requirements $u_x = \pm 1$ a.e. and $u = 0$ cannot be met. Note that every minimizing sequence, in particular u^k , tends weakly to zero in $W_0^{1,4}(0, \pi)$, but that zero is not a minimizer. Ball and James [1987] suggested that incompatibility at boundaries between regions of a material in different phases could be overcome by two variants of one of the phases assuming a structure in which bands of each variant are finely interspersed. Such a spatial arrangement would correspond to an element of a minimizing sequence for the total elastic energy: in the (simplified) example above the two variants correspond to $u_x = +1$ and $u_x = -1$. We will enlarge on this remark in Section 7. Despite an expanding literature on the variational formulation of this problem, little is known of the dynamics by which such a fine mixture might be created or evolve. The models treated in this paper, while not directly derived from the underlying physical problem, are designed to provide insight into this question.

The second area on which our examples shed light is that of the structure of attracting sets for infinite dimensional, dissipative, evolution equations. In several examples in which an associated linearized problem has a spectrum of stable eigenvalues separated by suitable gaps, it is known that finite dimensional attracting sets and even inertial manifolds exist. (cf. Constantin et al. [1988], Temam [1988], Doering et al. [1988]). An inertial manifold is a smooth, finite dimensional submanifold of the phase space, invariant under the (semi-) flow, which attracts all solutions at an asymptotically exponential rate as $t \rightarrow +\infty$. In such cases the long time behaviour is governed by a finite dimensional dynamical system, a set of “determining modes”, regardless of the initial data. In contrast, the present examples show that strong dissipation can coexist with an infinite set of unstable modes and that energy can cascade to arbitrarily high wavenumber as $t \rightarrow +\infty$, but, consistent with energy decay, no periodic or other recurrent motions exist. Whether arbitrarily fine structure is realized or not depends on the form of the equation: we exhibit one example, based on the local energy function (1.1), whose solutions do not minimize energy dynamically, and two examples for which most solutions do in fact dynamically explore minimizing sequences. These latter share a feature of the Becker-Döring cluster equations studied by Ball et al. [1986], Ball and Carr [1988], and Slemrod [1988], who proved that mass asymptotically escapes to infinite clusters for initial data possessing supercritical density. As discussed in these papers, it is an open problem for the Becker-Döring equations to understand the details of how increasingly larger clusters develop. In one of our examples we are able to give an analogous description, showing how energy moves through the wavenumber spectrum as $t \rightarrow \infty$, and how the initial data strongly influences the dynamical development of solutions.

The contents of this paper are as follows. In Section 2 we describe the model equations and obtain some basic results on energy decay, stationary solutions and linearized stability. Section 3 contains existence and uniqueness results for the first two models. In Section 4 we begin to address the asymptotic behavior of solutions. We show that solutions of the “local” model do not minimize energy, whereas almost all solutions of the other models do so. A detailed study of how this occurs for one of the models is carried out in Section 5. Numerical simulations which illustrate these results are presented in Section 6 and concluding comments are given in Section 7.

Throughout the paper $\|f\| = (\int_0^\pi |f(x)|^2 dx)^{1/2}$ and $(f, g) = \int_0^\pi f(x)\bar{g}(x) dx$ denote the L^2 norm and inner product of (complex valued) functions defined on the domain $0 \leq x \leq \pi$. $\{f, g\}$ denotes the ordered

pair of functions f, g . For $s = 1, 2, \dots$, $1 \leq p \leq \infty$, $W^{s,p} = W^{s,p}(0, \pi)$ denotes the usual Sobolev space of functions whose derivatives of all orders $m \leq s$ belong to $L^p(0, \pi)$. $W_0^{1,p}$ denotes the space of $W^{1,p}$ functions whose continuous representatives vanish at $x = 0, \pi$. We write $H^s = W^{s,2}$, $H_0^1 = W_0^{1,2}$ and denote the associated norms $\|\cdot\|_s$ and $\|\cdot\|_1$. We also use H^s for noninteger values of s . If $I \subset \mathbb{R}$ is an interval, we write $C^r(I, C^s)$ for the space of r -times continuously differentiable maps from I into the space $C^s = C^s([0, \pi])$ of s -times continuously differentiable functions on $[0, \pi]$. We write C^0 as C . For more details see Adams [1975] or Yoshida [1980]. The basic tools used are existence and uniqueness results of Henry [1981] for abstract evolution equations with the modified definition of solutions due to Miklavčič [1985], and stable, unstable and center manifold results for PDE and ODE (cf. Carr [1981]). Some of the results of this paper were announced in Ball [1990], where additional background material and references may also be found.

2. THE MODEL EQUATIONS: PRELIMINARY ANALYSIS.

Here we introduce three model equations. While the first has some mechanical relevance, all three, and especially the latter two, are presented mainly as mathematically tractable models which exhibit features relevant to the physics of fine structure.

2.1 Three Models

Model 1 is based on the potential energy (1.1), mentioned earlier. The associated total energy (kinetic plus potential) is

$$E_1[u, u_t] = \frac{1}{2}\|u_t\|^2 + \int_0^\pi \frac{1}{4}(u_x^2 - 1)^2 dx + \frac{\alpha}{2}\|u\|^2 \quad (2.1)$$

and the evolution equation and boundary conditions are given by

$$u_{tt} = (u_x^3 - u_x + \beta u_{xt})_x - \alpha u, \quad (2.2a)$$

$$u(0, t) = u(\pi, t) = 0. \quad (2.2b)$$

The additional term βu_{xt} in (2.2a) represents viscoelastic damping. The specific choice of the function $\int_0^\pi \frac{1}{4}(u_x^2 - 1)^2 dx = \int_0^\pi \mathcal{V}_1(u_x) dx$ is not crucial. One can pick any two well potential \mathcal{V}_1 , with a corresponding, non-monotone, cubic-like stress-strain function $\sigma(u_x) = \mathcal{V}'_1(u_x)$, and obtain similar results. This

model crudely represents the behavior of a one-dimensional nonlinear viscoelastic continuum, bonded, with “strength” α , to a rigid substrate.

In model 2, which is rather more tractable, we replace the local nonlinear term $u_x^2 u_{xx}$ in (2.2a) by the spatially averaged term $\|u_x\|^2 u_{xx}$, obtaining a non-local model with total energy

$$E_2[u, u_t] = \frac{1}{2}\|u_t\|^2 + \frac{1}{4}(\|u_x\|^2 - 1)^2 + \frac{\alpha}{2}\|u\|^2 \quad (2.3)$$

and evolution equation

$$u_{tt} = (\|u_x\|^2 - 1)u_{xx} - \alpha u + \beta u_{xxt}, \quad (2.4a)$$

$$u(0, t) = u(\pi, t) = 0. \quad (2.4b)$$

Model 3 is obtained simply by replacing the second time derivative in (2.4a) by a first derivative, to yield the pseudo parabolic equation

$$u_t = (\|u_x\|^2 - 1)u_{xx} - \alpha u + \beta u_{xxt}, \quad (2.5)$$

which has the same stationary solutions as (2.4), but whose diagonal structure permits a complete characterization of the asymptotic behavior of solutions.

We concentrate on the first and second of these models. We are able to give a fairly complete analysis of model 2, but several open questions remain regarding model 1.

Assuming that solutions exist and are sufficiently smooth, facts to be established in Section 3, a straightforward calculation reveals that the energy functions (2.1) and (2.3), differentiated along solutions of (2.2) and (2.4) respectively, both satisfy

$$\frac{dE_j}{dt} = -\beta\|u_{xt}\|^2. \quad (2.6j)$$

For model 3, we define a (purely potential) energy

$$E_3[u] = \frac{1}{4}(\|u_x\|^2 - 1)^2 + \frac{\alpha}{2}\|u\|^2 \quad (2.7)$$

and compute, integrating by parts,

$$\begin{aligned} \frac{dE_3}{dt} &= (\|u_x\|^2 - 1)(u_x, u_{xt}) + \alpha(u, u_t) \\ &= -\left(\left[(\|u_x\|^2 - 1)u_{xx} - \alpha u \right], u_t \right) \\ &= -\|u_t\|^2 - \beta\|u_{xt}\|^2. \end{aligned} \quad (2.8)$$

Thus, in all three models the energy E_j is a Liapunov function: that is, E_j is nonincreasing along solutions (and strictly decreasing provided $\|u_{xt}\|$ (or $\|u_{xt}\|$ and $\|u_t\|$) $\neq 0$). Since we also have the lower bounds

$$E_j \geq 0, \quad j = 1, 2, 3, \quad (2.9)$$

we expect that solutions will in some sense approach stationary states or equilibria given by the boundary value problems

$$(u_x^3 - u_x)_x - \alpha u = 0, \quad u(0) = u(\pi) = 0; \quad (2.10)$$

$$(\|u_x\|^2 - 1)u_{xx} - \alpha u = 0, \quad u(0) = u(\pi) = 0, \quad (2.11)$$

in models 1 and 2, 3 respectively. We now turn to a study of those equilibria.

2.2 Equilibrium States.

Rewriting (2.10) as a system

$$\begin{aligned} u_x &= v, \\ v_x &= \frac{\alpha u}{3v^2 - 1}, \end{aligned} \quad (2.12)$$

we easily obtain the phase portrait of Figure 1, with solutions lying on the level sets of the first integral (obtained by multiplying (2.10) by u_x and integrating):

$$\frac{3v^4}{4} - \frac{v^2}{2} - \frac{\alpha u^2}{2} = \text{const.} \quad (2.13)$$

There are singularities along the lines $v = \pm 1/\sqrt{3}$. The solutions of (2.10) of interest to us are obtained by fitting together segments of orbits in the range $1/\sqrt{3} < |v| < 2/\sqrt{3}$ with appropriate jump conditions. Let $\tilde{u}(x)$ be such a solution and denote the L^∞ and $W^{1,\infty}$ norms of u by

$$\|u\|_\infty = \operatorname{ess\,sup}_{x \in [0, \pi]} |u(x)|, \quad \|u\|_{1,\infty} = \|u\|_\infty + \|u_x\|_\infty.$$

We recall that $\tilde{u} \in W_0^{1,1}$ is a *strong relative minimizer* of the potential energy

$$V[u] = \int_0^\pi \mathcal{V}(u, u_x) dx, \quad (2.14)$$

where $\mathcal{V}(u, u_x) \stackrel{\text{def}}{=} \frac{1}{4}(u_x^2 - 1)^2 + \frac{\alpha u^2}{2}$, if for some $\varepsilon > 0$, $V[\tilde{u}] \leq V[u]$ for all $u \in W_0^{1,1}(0, \pi)$ satisfying $\|u - \tilde{u}\|_\infty \leq \varepsilon$. In contrast, \tilde{u} is a *weak relative minimizer* if $V[\tilde{u}] \leq V[u]$ for all $u \in W_0^{1,1}(0, \pi)$ satisfying

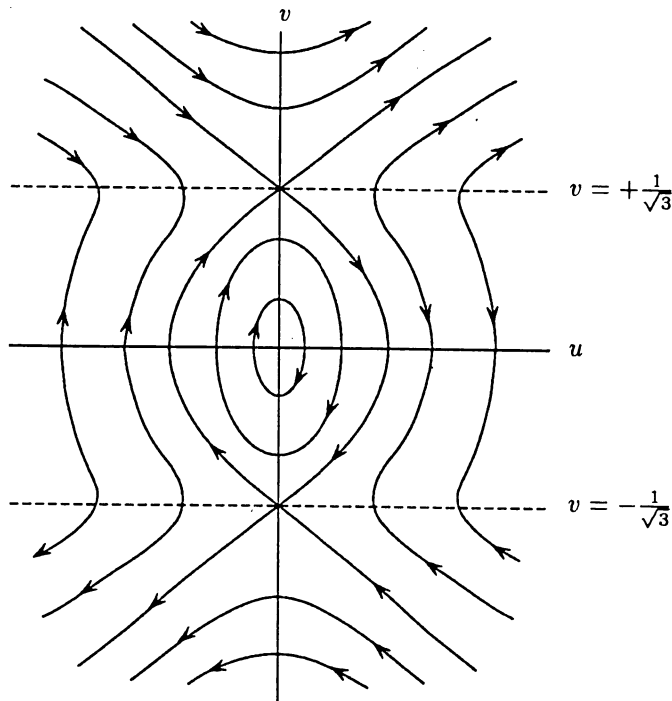

Figure 1 Phase portrait of (2.12)

$\|u - \tilde{u}\|_{1,\infty} \leq \varepsilon$. Moreover, if \tilde{u} is a weak relative minimizer then (cf. Cesari [1983, p. 61ff.]) the weak Euler-Lagrange equation

$$\frac{\partial \mathcal{V}}{\partial u_x}(\tilde{u}, \tilde{u}_x)(x) = \int_0^x \frac{\partial \mathcal{V}}{\partial u}(\tilde{u}, \tilde{u}_x)(s) ds + \text{const.} \quad (2.15)$$

holds; in particular, $\frac{\partial \mathcal{V}}{\partial u_x}$ is continuous at jumps in u_x , providing the condition we need to piece orbit segments together. Conversely, if $\tilde{u} \in W_0^{1,\infty}$ is a solution of (2.15) such that $|u_x|$ lies in a closed subset of $(1/\sqrt{3}, 2/\sqrt{3})$ for a.e. x , then \tilde{u} is a weak relative minimizer. This follows simply from a Taylor expansion with remainder, noting that $(\partial^2 \mathcal{V} / \partial u_x^2)(\tilde{u}, \tilde{u}_x) > \gamma > 0$ a.e. for some γ .

Using this we can easily construct uncountably many weak relative minimizers for (2.14), with $\sigma(u_x) = u_x^3 - u_x$ continuous at jumps. There can be arbitrarily many jumps in u_x , located with complete freedom apart from the minimal constraint that the trajectory begin at $x = 0$ on the line $u = 0$ and end at $x = \pi$ on $u = 0$ to satisfy the boundary conditions.

We remark that there are no strong relative minimizers of V . That $\tilde{u} = 0$ is not a strong relative minimizer follows by considering the minimizing sequence u^k discussed in the introduction. On the other

hand, if $\tilde{u} \not\equiv 0$ let x_0 be a point where $|\tilde{u}|$ is maximized. Assuming without loss of generality that $\tilde{u}(x_0) > 0$, it is easily proved that for $\varepsilon > 0$ and sufficiently small the function \tilde{u}_ε defined by

$$\tilde{u}_\varepsilon(x) = \min[\tilde{u}(x), \tilde{u}(x_0) - \varepsilon + |x - x_0|]$$

belongs to $W_0^{1,1}$, satisfies $V(\tilde{u}_\varepsilon) < V(\tilde{u})$, and $\lim_{\varepsilon \rightarrow 0} \|\tilde{u}_\varepsilon - \tilde{u}\|_\infty = 0$ (see Figure 2).

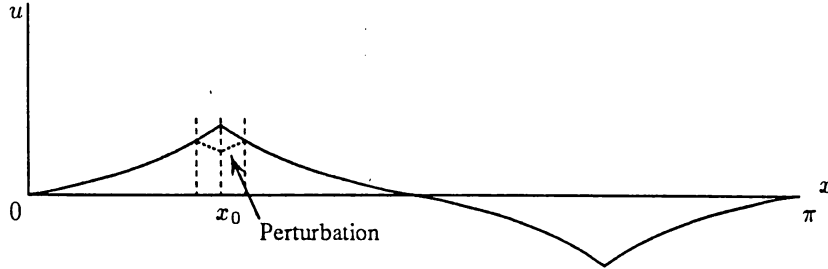

Figure 2 A small $\|\cdot\|_\infty$ perturbation lowers $V(u)$.

When $\alpha = 0$ the phase portrait of Figure 1 degenerates into horizontal lines. Then any solution for which $v = u_x = \pm 1$ a.e. is an absolute minimizer, while any solution for which $1/\sqrt{3} < |v| < 2\sqrt{3}$ is a weak relative minimizer. All these are exponentially stable in an appropriate norm, as shown by Pego [1987, Theorem 4.1]. We obtain a similar exponential stability result for $\alpha \neq 0$, below.

In contrast to the uncountable continuum of equilibria satisfying (2.10), equations (2.4) and (2.5) have only countable sets of equilibria. This is easily seen directly from (2.4a), or, as we now do, by expanding $u(x, t)$ in the orthonormal Fourier series

$$u(x, t) = \sum_{k=1}^{\infty} a_k(t) \sqrt{\frac{2}{\pi}} \sin kx, \quad (2.16)$$

and projecting (2.4a) onto each basis function in turn to obtain the infinite set of ordinary differential equations:

$$\ddot{a}_k + \beta k^2 \dot{a}_k + k^2 \left(\frac{\alpha}{k^2} - 1 + \sum_{j=1}^{\infty} j^2 a_j^2 \right) a_k = 0, \quad k = 1, 2, \dots \quad (2.17)$$

for the coefficients a_k . Here $(\dot{})$ denotes $d()/dt$. In addition to the trivial solution $a_k = 0, \forall k$ or $u \equiv 0 \stackrel{\text{def}}{=} u_0^\pm$, the equilibria of (2.17) are easily seen to occur in pairs

$$a_k^\pm = \pm \frac{1}{k} \sqrt{1 - \frac{\alpha}{k^2}}, \quad a_j = 0, \quad j \neq k, \quad (2.18)$$

for all k such that $k^2 > \alpha$. That no “mixed-mode” equilibria exist is clear from the requirement that, from (2.4a), any non-trivial equilibrium is an eigenfunction of d^2/dx^2 , or, in terms of the representation (2.16):

$$\sum_{j=1}^{\infty} j^2 a_j^2 = 1 - \frac{\alpha}{k^2} \quad (2.19)$$

for any $a_k \neq 0$. Reconstructing the functions from (2.18) via (2.16), we have the countable set of equilibria

$$u_0^\pm = 0, \quad u_k^\pm = \frac{1}{k} \sqrt{\frac{2}{\pi} \left(1 - \frac{\alpha}{k^2}\right)} \sin kx, \quad k = K, K+1, \dots \quad (2.20)$$

where $K = K(\alpha) = \min[k : k^2 - \alpha > 0]$. We observe that, since

$$E_2[u_k^\pm, 0] = \frac{\alpha}{2k^2} \left[1 - \frac{\alpha}{2k^2}\right] \quad (2.21)$$

approaches the lower bound 0 as $k \rightarrow \infty$, $\{u_k^\pm, 0\}_{k=K}^\infty$ is a minimizing sequence for this functional. The same conclusions hold for equation (2.5), since it only differs in the dynamical term. The analog of (2.17) in this case is the first order equation

$$\dot{a}_k = \frac{k^2}{1 + \beta k^2} \left(1 - \frac{\alpha}{k^2} - \sum_{j=1}^{\infty} j^2 a_j^2\right) a_k. \quad (2.22)$$

2.3 Linear Stability

We now obtain the first results suggestive of the types of asymptotic behavior that might be expected: we consider the equations linearized about the equilibria described above.

We first consider models 2 and 3, since the analysis is elementary. Linearizing (2.4a) at the trivial solution $u_0 \equiv 0$ we find the eigenfunctions $\{\sin lx\}$ and eigenvalues

$$\begin{aligned} \lambda_l &= \frac{\beta l^2}{2} \left(-1 \pm \sqrt{1 + \frac{4(l^2 - \alpha)}{\beta^2 l^4}} \right) \\ &\sim -\beta l^2 - \frac{1}{\beta} + O\left(\frac{1}{l^2}\right), \quad \frac{1}{\beta} + O\left(\frac{1}{l^2}\right) \text{ as } l \rightarrow \infty. \end{aligned} \quad (2.23)$$

Linearization about the nontrivial states $u_k^\pm(x) (k^2 > \alpha)$ gives the equation

$$\begin{aligned} v_{tt} &= (\|u_{k,x}^\pm\|^2 - 1)v_{xx} + 2(u_{k,x}^\pm, v_x)u_{k,xx}^\pm - \alpha v + \beta v_{xxt}, \\ v(0, t) &= v(\pi, t) = 0, \end{aligned} \quad (2.24)$$

and, using (2.20) and the fact that

$$\|u_{k,x}^\pm\|^2 = \int_0^\pi \frac{2}{\pi} \left(1 - \frac{\alpha}{k^2}\right) \cos^2 kx \, dx = 1 - \frac{\alpha}{k^2}, \quad (2.25)$$

(2.24) becomes

$$v_{tt} = -\frac{\alpha}{k^2} v_{xx} - \frac{4k}{\pi} \left(1 - \frac{\alpha}{k^2}\right) \left(\int_0^\pi v_x \cos kx \, dx\right) \sin kx - \alpha v + \beta v_{xxt}, \quad (2.26)$$

which has the eigenfunctions $\{\sin lx\}$ and eigenvalues

$$\left. \begin{aligned} \frac{\beta l^2}{2} \left(-1 \pm \sqrt{1 + \frac{4\alpha}{\beta^2 l^2} \left(\frac{1}{k^2} - \frac{1}{l^2}\right)}\right), \quad l \neq k, \\ \frac{\beta l^2}{2} \left(-1 \pm \sqrt{1 - \frac{8}{\beta^2 l^2} \left(1 - \frac{\alpha}{l^2}\right)}\right), \quad l = k. \end{aligned} \right\} \quad (2.27)$$

Clearly all of these equilibria are unstable, each one having a countable set of positive eigenvalues corresponding to the positive square roots in (2.23) and, for $l > k$, in (2.27). As $l \rightarrow \infty$ for fixed k , the eigenvalues of (2.27) take the forms

$$\begin{aligned} -\beta l^2 - \frac{\alpha}{\beta} \left(\frac{1}{k^2} - \frac{1}{l^2} \left(1 + \frac{\alpha}{\beta^2 k^4}\right)\right) + O\left(\frac{1}{l^4}\right) \\ \frac{\alpha}{\beta} \left(\frac{1}{k^2} - \frac{1}{l^2} \left(1 + \frac{\alpha}{\beta^2 k^4}\right)\right) + O\left(\frac{1}{l^4}\right), \end{aligned} \quad (2.28)$$

so that every equilibrium u_k^\pm is exponentially unstable, albeit increasingly weakly, since the positive eigenvalues accumulate on $\alpha/\beta k^2$ from below as $l \rightarrow \infty$ and $\alpha/\beta k^2 \rightarrow 0^+$ as $k \rightarrow \infty$.

In the case of model 3, a similar computation yields

$$\lambda_l = \frac{l^2 - \alpha}{1 + \beta l^2} \quad (2.29)$$

for the trivial solution and

$$\left. \begin{aligned} \lambda_l = \frac{\alpha(l^2 - k^2)}{k^2(1 + \beta l^2)}, \quad l \neq k \\ \lambda_l = \frac{-2(l^2 - \alpha)}{(1 + \beta l^2)}, \quad l = k \end{aligned} \right\} \quad (2.30)$$

for the equilibria $u_k^\pm (k^2 > \alpha)$. The eigenfunctions are again $\{\sin lx\}$. These equilibria are also all exponentially unstable.

These results suggest that typical solutions will not approach any of the equilibria as $t \rightarrow +\infty$, since each equilibrium has a non-empty unstable manifold. In Sections 3 and 4 we prove that this is, indeed, the case.

Model 1, unfortunately, does not permit such a detailed analysis; instead we have an exponential *stability* result for solutions linearized about states $\bar{u}(x)$ satisfying

$$\sigma'(\bar{u}_x) = 3\bar{u}_x^2 - 1 \geq \sigma_0 > 0 \quad \text{a.e.} \quad (2.31)$$

and subject to perturbations which do not move or introduce new discontinuities in u_x . However, this result is best stated in terms of the transformed variables used in our existence and uniqueness theorems, and so we defer it until the end of the next section.

3. EXISTENCE AND UNIQUENESS

The primary purpose of this section is to prove the global existence, uniqueness and regularity of solutions for model 1 and 2. For model 1, consider the equations

$$u_{tt} = (\sigma(u_x) + \beta u_{xt})_x - \alpha u, \quad u(0, t) = u(\pi, t) = 0, \quad (3.1a, b)$$

with initial data

$$u(x, 0) = u_0(x), \quad u_t(x, 0) = u_1(x), \quad 0 < x < \pi. \quad (3.1c)$$

DEFINITION. Let $T > 0$. By a solution of (3.1) on $[0, T)$, we mean a pair

$$\{u, v\} \in C([0, T), H_0^1 \times L^2) \cap C^1((0, T), H_0^1 \times L^2)$$

with $\sup_{0 \leq t < T} \|u_x(\cdot, t)\|_\infty < C(T)$, which satisfies $\{u, v\} = \{u_0, u_1\}$ at $t = 0$, and for $t > 0$,

$$u_t = v, \quad v_t = (\sigma(u_x) + \beta v_x)_x - \alpha u,$$

taking x -derivatives in the sense of distributions on $(0, \pi)$.

THEOREM 3.1 Global existence and uniqueness for model 1.

(a) (Strong Solutions). Suppose $u_0 \in W_0^{1, \infty}$, $u_1 \in L^2$. Then for any $T > 0$, a unique solution of (3.1) on $[0, T)$ exists. This solution is a “strong solution” in the sense that it also satisfies

$$\{u, u_t\} \in C([0, \infty), W_0^{1, \infty} \times L^2) \cap C^1((0, \infty), W_0^{1, \infty} \times C)$$

and

$$u_{tt} \in C((0, \infty), C), \quad \sigma(u_x) + \beta u_{xt} \in C((0, \infty), C^1),$$

while the equation (3.1a) holds pointwise for all $t > 0$, for a.e. x . Furthermore, we have

$$\sup_{t \geq 0} \|u(\cdot, t)\|_{1, \infty} < \infty, \quad \sup_{t > \tau} \|u_t(\cdot, t)\|_{1, \infty} < \infty \quad \text{for all } \tau > 0,$$

and the energy identity (2.6₁) holds for $t > 0$.

(b) (Classical Solutions). Suppose $u_0 \in C^2, u_1 \in H^s$ for some $s > \frac{1}{2}$, and $u_0(0) = u_0(\pi) = 0 = u_1(0) = u_1(\pi)$. Then the solution from part (a) also satisfies

$$\{u, u_t\} \in C([0, \infty), C^2 \times C) \cap C^1((0, \infty), C^2 \times C),$$

and (3.1a) holds for all $t > 0, 0 < x < \pi$.

For model 2, consider the equations

$$u_{tt} = ((\|u_x\|^2 - 1)u_x + \beta u_{xt})_x - \alpha u, \quad u(0, t) = u(\pi, t) = 0 \quad (3.2a, b)$$

with initial data

$$u(x, 0) = u_0(x), \quad u_t(x, 0) = u_1(x), \quad 0 < x < \pi. \quad (3.2c)$$

The definition of solution is as above for (3.1), but the restriction on $\|u_x(\cdot, t)\|_\infty$ is dropped.

THEOREM 3.2 *Global existence and uniqueness for model 2.*

(a) Suppose $u_0 \in H_0^1, u_1 \in L^2$. Then for any $T > 0$, a unique solution of (3.2) on $[0, T)$ exists. The solution also satisfies $\{u, u_t\} \in C^1((0, \infty), H_0^1 \times C)$ and

$$u_{tt} \in C((0, \infty), C), \quad (\|u_x\|^2 - 1)u_x + \beta u_{xt} \in C((0, \infty), C^1),$$

and equation (3.2a) holds pointwise for all $t > 0$, for a.e. x . Moreover, for $t \geq 0$ the map $\{u_0, u_1\} \mapsto \{u(t), u_t(t)\}$ is smooth on $H_0^1 \times L^2$. The energy E_2 of (2.3) is continuous for $t \geq 0$ and continuously differentiable for $t > 0$, (2.6₂) holds for $t > 0$ and for $t \geq 0$ we have

$$E_2(t) - E_2(0) = -\beta \int_0^t \|u_{xt}(s)\|^2 ds. \quad (3.3)$$

(b) Suppose $u_0 \in W^{1, \infty}, u_1 \in L^2$. Then the unique solution to (3.2) of part (a) also satisfies $\{u, u_t\} \in C([0, \infty), W_0^{1, \infty} \times L^2) \cap C^1((0, \infty), W_0^{1, \infty} \times C)$.

3.1 Preparatory Transformations

Both proofs use a transformed equation, as in Pego [1987]. We define new variables $p(x, t), q(x, t)$, where

$$p(x, t) = \int_0^x u_t(s, t) ds - \frac{1}{\pi} \int_0^\pi \int_0^x u_t(s, t) ds dx, \quad q = \beta u_x - p, \quad (3.4)$$

observing that $p_x = u_t$ and that p and q have zero mean. Let B denote the solution operator for the Neumann problem $Bw = U$, where

$$\begin{aligned} U_{xx} &= w - \frac{1}{\pi} \int_0^\pi w dx \quad \text{for } 0 < x < \pi \\ U_x(0, \cdot) &= U_x(\pi, \cdot) = 0, \quad \int_0^\pi U dx = 0, \end{aligned}$$

namely

$$U = \int_0^x \int_0^y w dz dy - \frac{1}{\pi} \int_0^\pi \int_0^x \int_0^y w dz dy dx, \quad (3.5a)$$

or

$$U(x, \cdot) = \int_0^\pi G(x, y) w(y, \cdot) dy,$$

where the Green's function is

$$G(x, y) = \begin{cases} y - \frac{1}{2\pi}(x^2 + y^2) - \frac{\pi}{3}, & x < y, \\ x - \frac{1}{2\pi}(x^2 + y^2) - \frac{\pi}{3}, & y < x. \end{cases} \quad (3.5b)$$

Equations (3.1) and (3.2) then transform to

$$\begin{aligned} p_t &= \beta p_{xx} + \mathcal{F}_j((p+q)/\beta), \\ q_t &= -\mathcal{F}_j((p+q)/\beta), \end{aligned} \quad (3.6_j)$$

where the \mathcal{F}_j are, respectively

$$\mathcal{F}_1(w) = \sigma(w) - \frac{1}{\pi} \int_0^\pi \sigma(w) dx - \alpha Bw \quad (3.7_1)$$

for (3.1) and

$$\mathcal{F}_2(w) = (\|w\|^2 - 1)w - \alpha Bw \quad (3.7_2)$$

for (3.2). In both cases the boundary conditions become

$$p_x(0, t) = p_x(\pi, t) = 0. \quad (3.8)$$

Note that, unlike Model 1 with $\alpha = 0$ (Pego [1987], eqn (2.9)), the q equations are not ODEs for each $x \in (0, \pi)$: they involve non-local integral “coupling” terms. However, most of the techniques of Pego’s paper carry over for these problems.

In both cases we will treat (3.6;3.8) as an abstract parabolic equation on a Banach space X , of the form

$$z_t + Az = f_j(z), \quad (3.9_j),$$

where $z = \{p, q\}$, $Az = \{-\beta\Delta p, 0\}$ and $f_j(z) = \mathcal{F}_j((p+q)/\beta)\{1, -1\}$, $j = 1, 2$ respectively. Here Δ denotes the Laplacian. The space X will differ for each case. As in Pego [1987], we appeal to results of Henry [1981].

3.2 Proof of Theorem 3.1

The uniqueness of a solution of (3.1) on $[0, T)$ may be proved in a standard fashion, by subtracting two solutions, obtaining energy estimates, and applying Gronwall’s inequality. We omit the details. Regarding global existence, we first consider the simpler case of classical solutions. Thus, for part (b) we take $X = L_a^2 \times C_a^1$, where $L_a^2 = \{w \in L^2 \mid \int_0^\pi w dx = 0\}$ and $C_a^1 = \{w \in C^1 \mid \int_0^\pi w dx = 0\}$ are spaces of functions having zero mean. Since $D((-\Delta)^\gamma) \subset C_a^1$ for $\gamma > 3/4$, f_1 is smooth from $X^\delta = D((-\Delta)^\delta) \times C_a^1$ to X for $3/4 < \delta < 1$. Also, A is a sectorial operator (Henry [1981], Section 1.3). Now $u_0 \in C^2$ and $u_1 \in H^s$, $s > 1/2$, so, via (3.4), the initial data $\{p(x, 0), q(x, 0)\}$ lie in some such X^δ and thus Henry’s Theorems 3.3.3 and 3.5.2 yield a local solution for some $T > 0$ with

$$z \in C([0, T), X^\delta) \cap C^1((0, T), X^\gamma) \cap C((0, T), D(A))$$

for all $\gamma < 1$. This corresponds to a solution of (3.6₁-8) with

$$\begin{aligned} p &\in C([0, T), C_a^1) \cap C^1((0, T), C_a^1) \cap C((0, T), H^2), \\ q &\in C([0, T), C_a^1) \cap C^1((0, T), C_a^1), \end{aligned}$$

and, via $u = \int_0^x ((p+q)/\beta) dx$ and $u_{tt} = p_{xt}$:

$$\{u, u_t\} \in C([0, T), C^2 \times C) \cap C^1((0, T), C^2 \times C), \quad u_{tt} \in C((0, T), C).$$

In view of these local results, $E_1 \in C^1((0, T), \mathbb{R})$ and the energy identity (2.6₁) holds on $(0, T)$. In terms of $\{p, q\}$, the energy function is

$$E_1[p, q] = \int_0^\pi \left\{ \frac{p_x^2}{2} + \mathcal{V}_1((p+q)/\beta) + \frac{\alpha}{2} \left(B((p+q)/\beta) \right)_x^2 \right\} dx, \quad (3.10)$$

where $\mathcal{V}_1(w) = \frac{1}{4}(w^2 - 1)^2$. To obtain global existence, it will suffice to show that

$$\|p\|_\infty + \|q\|_\infty \leq C, \text{ independent of } t, T, \quad (3.11)$$

for then we may estimate

$$\|f_1(z)\|_X \leq K(1 + \|z\|_{X^\epsilon})$$

and appeal to Henry [1981], Corollary 3.3.5.

Now since E_1 is non-increasing, bounds on the initial data and the form of \mathcal{V}_1 imply that each component of (3.10) is uniformly bounded. Poincaré's inequality then yields

$$\|p\|_\infty \leq C_1, \quad \|B((p+q)/\beta)\|_\infty \leq C_1, \quad (3.12)$$

and, using the fact that $|\sigma(w)| \leq \mathcal{V}_1(w) + C_2$, it follows that

$$\left| \int_0^\pi \sigma(u_x) dx \right| \leq C_3. \quad (3.13)$$

From (3.6₁) we have

$$q_t = -\sigma((p+q)/\beta) + e_1 \quad (3.14)$$

where $e_1 = \frac{1}{\pi} \int_0^\pi \sigma((p+q)/\beta) dx - \alpha B((p+q)/\beta)$ and $\|e_1\|_\infty + \|p\|_\infty \leq C_4$, for some C_j independent of T .

We now interpret (3.14) as a classical ODE holding at each $x \in [0, \pi]$ so as to obtain pointwise information about q . For this purpose p and q are taken as the unique representatives of the solution that are continuous in x and t , supplied by the Sobolev imbedding Theorem. From $\sigma(w) = w^3 - w$ we see that, for each $x \in [0, \pi]$, $q(x, t)q_t(x, t) < 0$ for $q(x, t)$ sufficiently large. Thus for all x , the ODE (3.14) considered at x has a compact, positively invariant interval and so, for some C_5 ,

$$\|q\|_\infty \leq C_5. \quad (3.15)$$

Picking $C = \max[C_1, C_5]$ we have (3.11) and so global existence follows. This concludes the proof of part (b).

To prove part (a) we set $X = L_a^2 \times L^\infty$, with initial values in $X^{1/2} = H_a^1 \times L^\infty$. Henry's results yield a strong local solution of (3.6₁-8) with

$$\begin{aligned} p &\in C([0, T], H_a^1) \cap C^1((0, T), C^1) \cap C((0, T), W^{2, \infty}), \\ q &\in C([0, T], L^\infty) \cap C^1((0, T), L^\infty), \end{aligned}$$

and hence

$$\{u, u_t\} \in C([0, T], W_0^{1, \infty} \times L^2) \cap C^1((0, T), W_0^{1, \infty} \times C).$$

From (3.6₁) and (3.7₁) it now follows that

$$\sigma(u_x) + \beta u_{xt} = \frac{1}{\pi} \int_0^\pi \sigma(u_x) dx + \alpha B u_x + p_t \in C((0, T), C^1).$$

The energy identity (2.6₁) holds as before, as do the a priori bounds (3.12)–(3.13). To obtain the analog of (3.15) we use the fact that $p, e_1 \in C^1((0, T), W^{1, \infty})$. The local solution $q(t)$ lies in an equivalence class of essentially bounded measurable functions. Fixing any $t_0 \in (0, T)$, we can pick any pointwise-bounded representative $q_0^* \in q(t_0)$ and solve (3.14) for every x in $[0, \pi]$ to obtain a unique bounded $q^*(x, t)$, with $q^*(x, t_0) = q_0^*(x)$, that is C^1 in t for each x (on a neighborhood of t_0 that may depend on x), but not necessarily C^0 in x . Again $q^*(x, t)q_t^*(x, t) < 0$ for large $q^*(x, \cdot)$ implying that $\sup_{t \geq t_0} |q^*(x, t)| \leq C$, for some C independent of x, t_0 and T , and therefore that $q^*(x, \cdot) \in C^1([t_0, T], \mathbb{R})$ with $\|q^*\|_\infty \leq C$. Finally, considering p as given, q is a unique solution of an initial value problem for (3.14) considered as an ODE in L^∞ , so $q^*(\cdot, t) \in q(t)$ for all $t \in [t_0, T]$; hence (3.15) holds and global existence follows. This concludes the proof of part (a). \square

3.3 Proof of Theorem 3.2

In this case, for part (a) we pick $X = L_a^2 \times L_a^2$, with $L_a^2 = \{w \in L^2 \mid \int_0^\pi w dx = 0\}$ as before. Again A is a sectorial operator. The initial values $\{u_0, u_1\} \in H_0^1 \times L^2$ correspond to $\{p, q\} \in H_a^1 \times L_a^2$ ($H_a^1 = H^1 \cap L_a^2$) and it may be verified that $H_a^1 \times L^2 = X^{1/2} = D((A)^{1/2}) \subset X$ and $f_2 : X^{1/2} \rightarrow X$ can be seen to be smooth (see (3.7₂)). Henry's Theorems 3.3.3 and 3.5.2 then yield a local solution:

$$z \in C([0, T], X^{1/2}) \cap C^1((0, T), X^\gamma) \cap C((0, T), D(A)),$$

for all $\gamma < 1$, with $X^\gamma = D((-\Delta)^\gamma) \times L_a^2$. Moreover, for $\gamma > 3/4$ we have the inclusion $C^1 \supset D((-\Delta)^\gamma)$. In terms of $\{p, q\}$, this implies that

$$\begin{aligned} p &\in C([0, T], H_a^1) \cap C^1((0, T), C^1) \cap C((0, T), H^2), \\ q &\in C([0, T], L_a^2) \cap C^1((0, T), L_a^2), \end{aligned} \tag{3.16}$$

and using $u_t = p_x$, $u = \int_0^x ((p+q)/\beta) dx$, we have

$$\begin{aligned} u &\in C([0, T], H_0^1) \cap C^1((0, T), H_0^1), \\ u_t &\in C([0, T], L^2) \cap C^1((0, T), C) \cap C((0, T), H^1). \end{aligned}$$

To obtain global existence we again examine the energy, which is, in terms of $\{p, q\}$

$$E_2[p, q] = \frac{1}{2} \|p_x\|^2 + \frac{1}{4} \left(\|(p+q)/\beta\|^2 - 1 \right)^2 + \frac{\alpha}{2} \left\| \left(B((p+q)/\beta) \right)_x \right\|^2. \tag{3.17}$$

In view of (3.16), $E_2 \in C([0, T], \mathbb{R}) \cap C^1((0, T), \mathbb{R})$ and so the energy identities (2.6₂) and (3.3) hold for $t < T$. Once more from this and Poincaré's inequality it follows that

$$\|p\|_1 \leq C, \quad \|q\| \leq C, \tag{3.18}$$

for some C independent of T . Note that the bound on q is immediate in this case, due to the "simpler" form of E_2 . We conclude that the solution $z = \{p, q\}$ remains bounded in $X^{1/2}$ independent of t and T and hence, via Henry [1981; 3.3.5], that it exists globally in time. Smooth dependence on initial data follows from Henry [1981; 3.4.6]. Uniqueness is proved as in Theorem 3.1. This concludes part (a).

For part (b), we take $X = L_a^2 \times L_a^\infty$ with initial values in $X^{1/2}$, corresponding to the hypotheses on $\{u_0, u_1\}$. As before, A is sectorial and $f_2 : X^{1/2} \rightarrow X$ is smooth. Henry's Theorems 3.3.3 and 3.5.2 yield a local solution

$$z \in C([0, T], X^{1/2}) \cap C^1((0, T), X^\gamma) \cap C((0, T), D(A))$$

for all $\gamma < 1$, with $X^\gamma = D((-\Delta)^\gamma) \times L_a^\infty$. Taking $\gamma > 3/4$ as in part (a), we have local existence on $[0, T)$ for some $T < \infty$ with

$$\begin{aligned} p &\in C([0, T], H_a^1) \cap C^1((0, T), C^1) \cap C((0, T), H^2), \\ q &\in C([0, T], L_a^\infty) \cap C^1((0, T), L_a^\infty), \end{aligned}$$

or

$$\begin{aligned}
u &\in C([0, T], W^{1, \infty}) \cap C^1((0, T), W^{1, \infty}), \\
u_t &\in C([0, T], L^2) \cap C^1((0, T), C) \cap C((0, T), H^1), \\
u_{xt} &\in C((0, T), L_a^\infty).
\end{aligned}$$

Now f_2 takes bounded sets in $X^{1/2}$ to bounded sets in X and so, from Henry [1981; 3.3.5], solutions will either exist for all time or blow up in the L^∞ norm in finite time. From part (a) of the theorem $\|p\|_1$ is bounded for all time and so the latter alternative is equivalent to $\|q\|_\infty \rightarrow \infty$ in finite time. That this is impossible follows from the study of the second component of (3.6₂) viewed as an ODE in q at each x . As in the proof of Theorem 3.1.(b) we have that

$$q_t = (1 - \|u_x\|^2)q/\beta + e_2, \quad (3.19)$$

where $e_2 = (1 - \|u_x\|^2)p/\beta - \alpha B((p + q)/\beta)$ with $p, e_2 \in C^1((0, T), H^1)$ and $(1 - \|u_x\|^2) \in C^1((0, T), \mathbb{R})$. As before, a non-increasing E_2 together with Poincaré's inequality yields

$$\|p\|_\infty + |(1 - \|u_x\|^2)| + \|e_2\|_\infty \leq C, \quad (3.20)$$

for some C independent of T . Fixing any $t_0 \in (0, T)$ we can once again pick any pointwise-bounded representative $q_0^* \in q(t_0)$ and solve (3.19) for every x in $[0, \pi]$ to obtain a unique bounded $q^*(x, t)$ on a neighborhood of t_0 with $q^*(x, t_0) = q_0^*(x)$. From the form of (3.19), (3.20) and Gronwall's inequality it follows that for no x can $q^*(x, t)$ blow up in finite time, hence $q^*(x, \cdot) \in C^1([t_0, T], \mathbb{R})$. From the uniqueness of q in L^∞ , $q^*(t) \in q(t)$ for all $t \in [t_0, T)$, hence $\|q(t)\|_\infty$ cannot blow up in finite time, implying global existence. This completes the proof of part (b). \square

3.4 Linear Stability for Model 1

As promised in Section 2.3, we now give a linearization result for equation (2.2). It is more convenient to state it in terms of the transformed system (3.6₁₋₈). It is a modest generalization of Theorem 4.1 of Pego [1987], but now we have a simpler proof.

THEOREM 3.3 Linear Stability for Model 1

Suppose $\tilde{u}(x)$ is a stationary solution of (2.2) with possibly discontinuous strain, satisfying

$$\sigma'(\tilde{u}_x) = 3\tilde{u}_x^2 - 1 \geq \sigma_0 > 0 \text{ a.e.}$$

Then, for any $\delta < \min[\sigma_0/\beta, \beta/2]$ there exists $C_0 > 0$, such that a unique solution $\{p, q\}$ of (3.6₁)–(3.8) exists globally for $t > 0$ and satisfies

$$\|p(t)\|_1 \leq C_0 e^{-\delta t} \|p(0)\|_1, \quad \|q(t) - \beta\tilde{u}_x\|_\infty \leq C_0 e^{-\delta t} \|q(0) - \beta\tilde{u}_x\|_\infty,$$

provided that $\|p(0)\|_1$ and $\|q(0) - \beta\tilde{u}_x\|_\infty$ are sufficiently small and $\int_0^\pi p(x, 0) dx = 0 = \int_0^\pi q(x, 0) dx$.

Remark: Note that we require that the strain perturbation $(q - \beta\tilde{u}_x)$ be small in the L^∞ norm. This implies that new strain discontinuities cannot be introduced and it corresponds to the notion of a weak relative minimizer (Section 2.3). This stability result is difficult to interpret physically, since the class of permissible perturbations is restricted. However, see Section 4.4 below.

Proof: As in the proof of Theorem 3.1 we employ the abstract form (3.9₁) of (3.6₁-8) with $X = L_a^2 \times L_a^\infty$. Appealing to Theorem 5.1.1. of Henry [1981], it suffices to show that the spectrum of the linear operator $A - B_1$ lies in $\{\lambda \in \mathbb{C} | \text{Re} \lambda \geq \delta\}$, where B_1 is the linearization of f_1

$$B_1(p, q) = (\sigma'(\tilde{u}_x)w - \frac{1}{\pi} \int_0^\pi \sigma'(\tilde{u}_x)w dx - \alpha Bw)\{1, -1\}, \quad (3.21)$$

with $w = (p + q)/\beta$.

We first show that no eigenvalue of $A - B_1$ satisfies $\text{Re} \lambda < \delta$. Suppose that λ is such an eigenvalue with eigenfunction $z = \{p, q\}$. Then both real and imaginary parts of p lie in H^2 and the eigenvalue problem $(A - B_1)z = \lambda z$ for the linearized equation (from 3.6₁) yields

$$-\beta p_{xx} - \sigma'(\tilde{u}_x)w + \frac{1}{\pi} \int_0^\pi \sigma'(\tilde{u}_x)w dx + \alpha Bw = \lambda p, \quad (3.22a)$$

$$\sigma'(\tilde{u}_x)w - \frac{1}{\pi} \int_0^\pi \sigma'(\tilde{u}_x)w dx - \alpha Bw = \lambda q. \quad (3.22b)$$

Thus $\lambda(p + q)/\beta = \lambda w = -p_{xx}$, and since $Bp_{xx} = p$ (see (3.5)), we have, from (3.22a)

$$(\lambda^2 + \alpha)p + (\lambda\beta - \sigma'(\tilde{u}_x))p_{xx} + \frac{1}{\pi} \int_0^\pi \sigma'(\tilde{u}_x)p_{xx} dx = 0. \quad (3.23)$$

Now let $\lambda = a + ib$, multiply (3.23) by \bar{p}_{xx} (\bar{p} denotes complex conjugate) and integrate to obtain

$$\int_0^\pi \left\{ -(a^2 - b^2 + 2iab + \alpha)|p_x|^2 + (a\beta + ib\beta - \sigma'(\tilde{u}_x(x)))|p_{xx}|^2 \right\} dx = 0. \quad (3.24)$$

Note that the final term in (3.23) does not appear in (3.24) because we work in L_a^2 and $\int_0^\pi p_{xx} dx = -\frac{1}{\lambda} \int_0^\pi w dx = \int_0^\pi \bar{p}_{xx} dx = 0$. Taking real and imaginary parts, this yields

$$-(a^2 - b^2 + \alpha)\|p_x\|^2 + \int_0^\pi (a\beta - \sigma'(\tilde{u}_x))|p_{xx}|^2 dx = 0, \quad (3.25a)$$

$$b\{-2a\|p_x\|^2 + \beta\|p_{xx}\|^2\} = 0. \quad (3.25b)$$

If $b = 0$, then clearly $a \geq \left(\min[\sigma'(u_x(x))] \right) / \beta = \sigma_0 / \beta$, from (3.25a), while if $b \neq 0$, Poincaré's inequality and (3.25b) imply that $a \geq \beta/2$. Thus $\text{Re}\lambda \geq \min[\sigma_0/\beta, \beta/2]$, as claimed.

We next show that the essential spectrum (i.e. the spectrum with discrete eigenvalues of finite multiplicity deleted) also lies in $\{\lambda \in \mathbb{C} | \text{Re}\lambda \geq \delta\}$. We split $A - B_1 = A - B_2 - B_3$ with

$$B_2(p, q) = \sigma'(\tilde{u}_x) \left(\frac{q}{\beta} \right) \{1, -1\}$$

$$B_3(p, q) = \left(\sigma'(\tilde{u}_x) \left(\frac{p}{\beta} \right) - \frac{1}{\pi} \int_0^\pi \sigma'(\tilde{u}_x) w dx - \alpha B w \right) \{1, -1\}$$

with $w = (p+q)/\beta$, as before. The resolvent of $A - B_2$ may be explicitly characterized for $\text{Re}\lambda < \min(\sigma_0/\beta, \beta)$ as

$$(\lambda - A + B_2)^{-1} = \begin{bmatrix} (\lambda + \beta\Delta)^{-1} & -(\lambda + \beta\Delta)^{-1}(\sigma'/\beta)(\lambda - \sigma'/\beta)^{-1} \\ 0 & (\lambda - \sigma'/\beta)^{-1} \end{bmatrix}.$$

Since B_3 is bounded in p and compact in q and $(\lambda + \beta\Delta)^{-1}$ is compact, it follows that $B_3(\lambda - A + B_2)^{-1}$ is compact. Thus $A - B_2 - B_3$ is a relatively compact perturbation of $A - B_2$ and has the same essential spectrum as $A - B_2$, contained in $\{\lambda \in C | \text{Re}\lambda \geq \min[\sigma_0/\beta, \beta]\}$. \square

4. ASYMPTOTIC BEHAVIOR

In this section we obtain several results which partially characterize the asymptotic behavior of *all* solutions of the three model equations.

4.1 Model 1 does not Minimize Energy

Pego [1987, Theorem 5.4] showed that an equation similar to (2.2), with $\alpha = 0$ and boundary conditions $(\sigma(u_x) + \beta u_{xt})(\pi, t) = P$ replacing $u(\pi, t) = 0$, exhibited convergence to equilibria having discontinuous

strain; moreover, he showed that, if the (smooth) initial strain data $u_{0,x}(x)$ has “near discontinuities” at x_1, x_2, \dots then these “sharpen up” and do not move much (Pego [1987, Theorem 6.1]). When $\alpha \neq 0$ the energy $E_1[u]$ contains the displacement term $\frac{\alpha}{2}\|u\|^2$ and one naturally asks if this can promote the creation of new discontinuities not present in the initial data. In particular, do “typical” solutions realize global minimizing sequences? The latter behavior is excluded by the following result.

THEOREM 4.1 *There is no solution of (2.2) which minimizes energy globally as $t \rightarrow \infty$, i.e. there is no solution such that $E_1(t) \rightarrow 0$ as $t \rightarrow \infty$.*

Proof: Again we work with the transformed equation (3.6₁)–(3.8). Assume that some (global) solution $\{p, q\}$ of (3.6₁)–(3.8) satisfies $\lim_{t \rightarrow \infty} E_1(p, q) = 0$, cf. (3.10). Then

$$\|p_x\|^2 \rightarrow 0, \quad \|u\| \rightarrow 0, \quad \text{and} \quad u_x = \frac{p+q}{\beta} \rightarrow \pm 1 \quad \text{in measure} \quad (4.1)$$

as $t \rightarrow \infty$ and hence, via Poincaré’s inequality and the facts that $\int_0^\pi p \, dx = \int_0^\pi B u_x \, dx = 0$, $(B u_x)_x = u$,

$$\|p\|_\infty \rightarrow 0, \quad \|B((p+q)/\beta)\|_\infty \rightarrow 0. \quad (4.2)$$

By Theorem 3.1(a), $u_x(\cdot, t)$ is bounded in L^∞ , and so $\sigma(u_x)$ is bounded in L^∞ . Since by (4.1), $\sigma(u_x) \rightarrow 0$ in measure, it follows from the bounded convergence theorem that

$$\frac{1}{\pi} \int_0^\pi \sigma\left(\frac{p+q}{\beta}\right) \, dx \rightarrow 0 \quad \text{as } t \rightarrow \infty. \quad (4.3)$$

As in the proof of Theorem 3.1(a), we take $q^*(x, t)$ to be a classical solution of (3.14) with $q^*(\cdot, t) \in q(t)$ for $t \geq t_0 > 0$. The results (4.2) and (4.3) above imply that, for each x ,

$$p(x, t) \rightarrow 0 \quad \text{and} \quad e_1(x, t) \rightarrow 0 \quad \text{as } t \rightarrow \infty, \quad (4.4)$$

and so, from (3.14) viewed as an “asymptotically autonomous” ODE, $q^*(x, t)$ converges for each $x \in (0, \pi)$ as $t \rightarrow \infty$ (cf. Pego [1987], Lemma 5.5). In fact let

$$q_- = \liminf_{t \rightarrow \infty} q^*(x, t), \quad q_+ = \limsup_{t \rightarrow \infty} q^*(x, t). \quad (4.5)$$

Then for any $q_0 \in (q_-, q_+)$ there exist sequences $t_i^\pm \rightarrow \infty$ as $i \rightarrow \infty$ with $q^*(x, t_i^\pm) = q_0$ and $\pm q_i^*(x, t_i^\pm) \geq 0$. From (3.14) we see that $\sigma(q_0/\beta) = 0$. But σ is not constant on any nontrivial interval and so $q_0 = q_- = q_+ = \lim_{t \rightarrow \infty} q^*(x, t)$.

Finally, since $q^*(x, t)$ converges as $t \rightarrow \infty$, by (4.4) so does $u_x(x, t)$. But from the boundedness of u_x in L^∞ and (4.1ii), it follows that

$$\lim_{t \rightarrow \infty} u_x(x, t) = 0 \quad \text{a.e.}$$

This contradicts (4.1iii). □

Remarks: 1. Theorems 3.3 and 4.1 suggest that every solution of (2.2) converges to some stationary solution as $t \rightarrow \infty$, but we have been unable to prove this. If this is true, one would further expect that, for generic initial data, the limiting stationary solution is a weak relative minimizer; recall that there are uncountably many such minimizers (see section 2.2).

2. Following the arguments of Pego [1987, Section 5], one can show that $\|p_x\|^2 \rightarrow 0$ for any solution, so that, for large t , q approximately satisfies

$$q_t = -\sigma(q/\beta) + \frac{1}{\pi} \int_0^\pi \sigma(q/\beta) dx + \alpha Bq/\beta. \quad (4.6)$$

This is an interesting equation in its own right. One can ask if almost all solutions of (4.6) (or of (2.2) or (3.6₁)) converge to a stationary state q_∞ , $p = 0$ with $\sigma'(q_\infty) > 0$ a.e., as the linearization result of Theorem 3.3 suggests. Do “new” discontinuities appear in q ? See Section 4.4, below.

4.2 Almost all solutions of Model 2 do minimize energy

We first obtain a dichotomy which implies that solutions behave either in a “finite dimensional” fashion, essentially involving only a finite set of Fourier modes, or that *all* Fourier modes are active and energy cascades out to infinity in wavenumber space. We then show that almost all initial data lead to the latter behavior.

PROPOSITION 4.2 Let $\{u, u_t\} \in X = H_0^1 \times L^2$ solve (2.4). Then as $t \rightarrow +\infty$, either $\{u, u_t\} \rightarrow \{u_k^\pm, 0\}$ strongly in X for some equilibrium u_k^\pm of (2.20) and $E_2(t) \rightarrow \frac{\alpha}{2k^2} \left[1 - \frac{\alpha}{2k^2} \right]$, or

$$\|u_t\| \rightarrow 0, \quad u \rightarrow 0 \text{ weakly in } H_0^1,$$

$$\|u_x\| \rightarrow 1 \text{ and } E_2(t) \rightarrow 0.$$

Proof: We first recall the uniform bounds established in the proof of Theorem 3.2, based on the fact that $E_2[u(\cdot, t)]$ is non-increasing in t and increases in $\|u_x\|$ for $\|u_x\| > 1$, namely

$$\|u\|, \|u_x\|, \|u_t\| < C \text{ (determined by initial data).} \quad (4.7)$$

Since (3.3) holds and E_2 is bounded below (2.9b) we also have

$$\int_0^\infty \|u_{xt}\|^2(t) dt < \infty, \quad (4.8)$$

and, via Poincaré's inequality

$$\int_0^\infty \|u_t\|^2(t) dt < \infty, \quad (4.9)$$

and hence, for any $\tau > 0$,

$$\lim_{t \rightarrow \infty} \int_t^{t+\tau} \|u_t\|^2(s) ds = 0. \quad (4.10)$$

Also, (2.6₂) and the lower bound $E_2 \geq 0$ imply that $E_2(t)$ approaches a limit, say E_∞ , as $t \rightarrow +\infty$.

The proof follows from three lemmas which characterize the asymptotic behavior of u_t and $\|u_x\|^2$ and which we prove later. Throughout $\tau > 0$ is fixed.

LEMMA 4.3 (i) $u_t \xrightarrow{L^2} 0$ as $t \rightarrow \infty$; (ii) $\lim_{t \rightarrow \infty} (u_t, u) = 0$.

LEMMA 4.4

$$\lim_{t \rightarrow \infty} \|u_x\|^2 \Big|_t^{t+\tau} = 0.$$

LEMMA 4.5

$$\lim_{t \rightarrow \infty} \left\{ \int_t^{t+\tau} \|u_x\|^4(s) ds - \tau \|u_x\|^4(t) \right\} = 0 \text{ and } \lim_{t \rightarrow \infty} \left\{ \int_t^{t+\tau} \|u\|^2(s) ds - \tau \|u\|^2(t) \right\} = 0.$$

The proof is based on various manipulations of the energy identity, which are justified in view of Theorem 3.2. We first compute

$$\frac{d}{dt} \left\{ (u_t, u) + \frac{\beta}{2} \|u_x\|^2 \right\} = \|u_t\|^2 + (u_{tt}, u) + \beta(u_x, u_{xt}) = \|u_t\|^2 - \|u_x\|^4 + \|u_x\|^2 - \alpha \|u\|^2 \stackrel{\text{def}}{=} F(t), \quad (4.11)$$

using the evolution equation (2.2a) and integration by parts. From (2.3), we have

$$F(t) = 2\|u_t\|^2 - \frac{1}{2}\|u_x\|^4 - 2E_2(t) + \frac{1}{2}, \quad (4.12)$$

and so, integrating (4.11) we obtain, for any fixed $\tau > 0$

$$\{(u_t, u) + \frac{\beta}{2}\|u_x\|^2\}_t^{t+\tau} = \int_t^{t+\tau} \{2\|u_t\|^2(s) - \frac{1}{2}\|u_x\|^4(s) - 2E_2(s) + \frac{1}{2}\} ds. \quad (4.13)$$

Taking the limit $t \rightarrow \infty$ and using (4.10) and Lemmas 4.3-4.5 and the fact that $E_2(t) \rightarrow E_\infty$ yields

$$0 = \frac{\tau}{2} \lim_{t \rightarrow \infty} \|u_x\|^4(t) + 2 \lim_{t \rightarrow \infty} \int_t^{t+\tau} \left(E_\infty - \frac{1}{4}\right) ds,$$

or

$$\lim_{t \rightarrow \infty} \|u_x\|^2 = \sqrt{1 - 4E_\infty}. \quad (4.14)$$

On the other hand, integrating (4.11) without using (4.12) and taking the limit once more yields

$$0 = \lim_{t \rightarrow \infty} \int_t^{t+\tau} \{\|u_t\|^2 - \|u_x\|^4 + \|u_x\|^2 - \alpha\|u\|^2\}(s) ds,$$

or, with (4.10), (4.14) and Lemma 4.5,

$$\alpha\tau \lim_{t \rightarrow \infty} \|u\|^2(t) = \tau(\sqrt{1 - 4E_\infty} - 1 + 4E_\infty). \quad (4.15)$$

Consequently, from the definition of E_2 in (2.3), we have

$$E_\infty = \lim_{t \rightarrow \infty} E_2(t) = \frac{1}{2} \lim_{t \rightarrow \infty} \|u_t\|^2 + \frac{1}{4}(\sqrt{1 - 4E_\infty} - 1)^2 + \frac{\alpha}{2} \left(\frac{\sqrt{1 - 4E_\infty} - 1 + 4E_\infty}{\alpha} \right),$$

which implies that

$$\|u_t\|^2(t) \rightarrow 0 \text{ as } t \rightarrow \infty. \quad (4.16)$$

It remains to describe the behavior corresponding to different limits E_∞ . To do this we turn to the Galerkin projection (2.17). Since $a_k = (u, \sin kx)$, Theorem 3.2 implies that a_k is C^1 for $t \geq 0$ and C^2 for $t > 0$ and that (2.17) holds for all $t > 0$. Moreover $\sum_{j=1}^{\infty} j^2 a_j^2 = \|u_x\|^2 \rightarrow \sqrt{1 - 4E_\infty}$, and so the system (2.17) is asymptotic to the infinite set of uncoupled linear ODEs, each one having the form

$$\ddot{a}_k + \beta k^2 \dot{a}_k + k^2 \left(\frac{\alpha}{k^2} - 1 + \sqrt{1 - 4E_\infty} \right) a_k = 0, \quad k = 1, 2, \dots \quad (4.17)$$

and having only the equilibrium $\{a_k, \dot{a}_k\} = \{0, 0\}$ provided that

$$E_\infty \neq -\frac{\alpha}{2k^2} \left(1 - \frac{\alpha}{2k^2}\right). \quad (4.18)$$

Now since $\|u\|^2 = \sum_1^\infty a_k^2$, $\|u_t\|^2 = \sum_1^\infty \dot{a}_k^2$ are uniformly bounded by (4.7), each $\{a_k, \dot{a}_k\}$ remains bounded for all t . A standard result for asymptotically autonomous ODEs implies that, for fixed k , the ω -limit set of the k th equation in (2.17) is invariant for the limiting autonomous equation (4.17), cf. Ball [1978 Section 4]. But provided (4.18) holds the only such invariant set is $\{a_k, \dot{a}_k\} = \{0, 0\}$. Hence $\{a_k(t), \dot{a}_k(t)\} \rightarrow 0$ and thus

$$\lim_{t \rightarrow \infty} \|u\|^2(t) = 0. \quad (4.19)$$

In that case, from (2.3) again we find that:

$$E_\infty = \frac{1}{4}(\sqrt{1-4E_\infty} - 1)^2 \Rightarrow E_\infty = +\frac{1}{4} \text{ or } 0. \quad (4.20)$$

The first case corresponds to convergence to the trivial solution u_0^\pm and, via (4.14), we have $\|u_x\| \rightarrow 0$ so that $u \rightarrow 0$ strongly in H_0^1 . In the second case, from (4.14) and (4.15)

$$\lim_{t \rightarrow \infty} \|u_x\|^2(t) = 1 \text{ and } \lim_{t \rightarrow \infty} \|u\|^2(t) = 0. \quad (4.21)$$

This, together with (4.16), establishes the second alternative of the proposition.

To deal with the remaining cases of convergence to a nontrivial equilibrium, suppose (4.18) is violated and $E_\infty = \frac{\alpha}{2k^2} \left(1 - \frac{\alpha}{2k^2}\right)$ for some $k \geq 1$. Then, by the previous argument $a_j \rightarrow 0$ for all $j \neq k$ and hence

$$\left(u - a_k(t) \sqrt{\frac{2}{\pi}} \sin kx\right) \xrightarrow{H_0^1} 0. \quad (4.22)$$

Thus $\left\|u - a_k(t) \sqrt{\frac{2}{\pi}} \sin kx\right\|^2 \rightarrow 0$ and $\|u\|^2 - \left\|a_k(t) \sqrt{\frac{2}{\pi}} \sin kx\right\|^2 \rightarrow 0$ as $t \rightarrow \infty$. However, from (4.15) we see that

$$\|u\|^2 \rightarrow \frac{\sqrt{1-4E_\infty} - 1 + 4E_\infty}{\alpha} = \frac{1}{k^2} \left(1 - \frac{\alpha}{k^2}\right)$$

and so that

$$a_k(t) \rightarrow \pm \frac{1}{k} \sqrt{1 - \frac{\alpha}{k^2}} \quad (4.23)$$

and we have strong convergence in H_0^1 to one of the equilibria u_k^\pm , $k \geq 1$ of (2.20). This, with (4.16) and the case $E_\infty = +\frac{1}{4}$ of (4.20) concludes the proof of the first alternative. \square

Proof of Lemma 4.3: Pick $\phi \in C_0^\infty$ with $\|\phi\| = K_0$ and let $f(t) = (u_t, \phi)^2$. Then, by the Schwarz inequality and (4.9)

$$\int_0^\infty f(t) dt \leq \int_0^\infty K_0^2 \|u_t\|^2 dt < \infty. \quad (4.24)$$

However,

$$\begin{aligned} \frac{df}{dt} &= 2(u_t, \phi)(u_{tt}, \phi) = 2(u_t, \phi) \left([(\|u_x\|^2 - 1)u_{xx} - \alpha u + \beta u_{xxt}], \phi \right) \\ &= 2(u_t, \phi) \left((1 - \|u_x\|^2)(u_x, \phi_x) - \alpha(u, \phi) + \beta(u_t, \phi_{xx}) \right) \end{aligned}$$

and so, by (4.7)

$$\left| \frac{df}{dt} \right| \leq 2CK_0(1 - C^2|CK_1 + \alpha CK_0 + \beta CK_2|)$$

where $\|\phi_x\| = K_1$, $\|\phi_{xx}\| = K_2$. Thus $|f|$ is bounded and f is uniformly continuous on $0 \leq t < \infty$ and so $f(t) \rightarrow 0$ as $t \rightarrow \infty$, in view of (4.24).

Next suppose $u_t \not\rightarrow 0$ as $t \rightarrow \infty$, so that there is a sequence $t_j \rightarrow \infty$ and a $\psi \in L^2$ such that, for some ε

$$|(u_t, \psi)(t_j)| \geq \varepsilon > 0, \quad \forall j.$$

If we pick $\phi \in C_0^\infty$ with $|\phi - \psi| < \varepsilon/2C$ a.e., then, since $(u_t, \psi)(t_j) = (u_t, \phi)(t_j) + (u_t, \psi - \phi)(t_j)$ we have

$$\varepsilon < (f(t_j))^{1/2} + C \frac{\varepsilon}{2C},$$

which yields a contradiction, for $f(t_j) \rightarrow 0$ as $j \rightarrow \infty$. This establishes (i); (ii) follows since u is bounded in H_0^1 and thus relatively compact in L^2 . \square

Proof of Lemma 4.4 Using the Schwarz inequality twice, we have

$$\begin{aligned} \|u_x\|^2 \Big|_t^{t+\tau} &= \int_t^{t+\tau} \frac{d}{ds} \|u_x\|^2(s) ds = \int_t^{t+\tau} 2(u_x, u_{xt})(s) ds \\ &\leq 2 \int_t^{t+\tau} \|u_x\| \|u_{xt}\|(s) ds \leq 2 \int_t^{t+\tau} C \|u_{xt}\|(s) ds \\ &\leq 2C\sqrt{\tau} \left(\int_t^{t+\tau} \|u_{xt}\|^2 ds \right)^{1/2}. \end{aligned}$$

But the last term approaches zero as $t \rightarrow \infty$, in view of (4.8). \square

Proof of Lemma 4.5 As above, we compute

$$\left| \int_t^{t+\tau} \|u_x\|^4(s) ds - \tau \|u_x\|^4(t) \right| = \left| \int_t^{t+\tau} \{ \|u_x\|^4(s) - \|u_x\|^4(t) \} ds \right|$$

$$\begin{aligned}
&= \left| \int_t^{t+\tau} \left\{ \int_t^s \frac{d}{dr} \|u_x\|^4(r) dr \right\} ds \right| = \left| \int_t^{t+\tau} \left\{ \int_t^s 4\|u_x\|^2(r)(u_x, u_{xt})(r) dr \right\} ds \right| \\
&\leq 4 \left| \int_t^{t+\tau} \left\{ \int_t^s C^3 \|u_{xt}\|(r) dr \right\} ds \right| \leq 4C^3 \tau \int_t^{t+\tau} \|u_{xt}\|(r) dr \\
&\leq 4C^3 \tau^{3/2} \left(\int_t^{t+\tau} \|u_{xt}\|^2 dr \right)^{1/2}.
\end{aligned}$$

The first statement follows from the observation that $\int_t^{t+\tau} \|u_{xt}\|^2 dr \rightarrow 0$ as $t \rightarrow \infty$, as in Lemma 4.4. The proof of the second statement follows in a similar fashion, considering

$$\left| \int_t^{t+\tau} \left\{ \int_t^s \frac{d}{dt} \|u\|^2(r) dr \right\} ds \right|$$

as $t \rightarrow \infty$ and using the fact that $(u, u_t) \rightarrow 0$, from Lemma 4.3. □

Remark: The use of Lemmas 4.3–4.5 in establishing (4.14) and (4.16) can be avoided by appeal to the first conclusion of Proposition 4.11, below. But since the proof of the latter is considerably more difficult, we include the elementary arguments above.

Proposition 4.2 establishes a dichotomy. It is easy to exhibit solutions which realize the first alternative. From the Galerkin representation (2.17) of the evolution equation it is clear that each $2N$ -dimensional subspace of the form $X_N \subset X = H_0^1 \times L^2$ with $X_N = \{ \{u, v\} \mid \{u, v\} = \sum_{j=1}^N \{a_j, b_j\} \sin jx \}$ is invariant. Suppose that we select initial data containing only a finite set of Fourier modes, so that $a_j(0) = \dot{a}_j(0) = 0$ for all $j > N$ and

$$u_0(x) = \sum_1^N a_k^0 \sqrt{\frac{2}{\pi}} \sin kx, \quad u_1(x) = \sum_1^N a_k^1 \sqrt{\frac{2}{\pi}} \sin kx, \quad (4.25)$$

then the solution $\{u, u_t\}$ will remain in X_N for all $t \geq 0$. Now X_N contains a finite collection of equilibria; specifically all those u_k^\pm with indices satisfying $\sqrt{\alpha} < k \leq N$ (cf. (2.20)), along with the trivial solution u_0 . Examination of the eigenvalues and eigenfunctions of (2.23–27) reveals that, *restricted to* X_N , the pair of equilibria u_N^\pm having “lowest energy” are linearly stable, provided $\alpha < N^2$ and they exist. All other equilibria have unstable manifolds which intersect X_N in non-empty sets, unless $\alpha \geq N^2$, in which case the unique equilibrium $u_0 \equiv 0$ in X_N is stable in that subspace. (A center manifold calculation, cf. Henry [1981], Chapter 6, covers the cases $\alpha = N^2$.) We conclude that almost all initial data satisfying (4.25) will approach u_N^\pm if $\alpha < N^2$ and u_0 if $\alpha \geq N^2$. Thus the first alternative essentially corresponds to finite

dimensional behavior, in which the initial data lies in the stable manifold of an equilibrium contained in some X_N , $N < \infty$.

It is tempting to argue that, since typical initial data contains arbitrarily high Fourier wavenumbers, almost all solutions will contain “unstable” Fourier components and hence realize the second alternative. That this is indeed the case is the content of the next result.

THEOREM 4.6 Let $X = H_0^1 \times L^2$. Then X is the disjoint union of two dense sets A_1, A_2 , of first and second category respectively, such that:

- (i) if $\{u_0, u_1\} \in A_1$, then $\{u, u_t\} \rightarrow \phi$ strongly in X , for some $\phi = \{u_k^+, 0\}$ or $\{u_k^-, 0\}$;
- (ii) if $\{u_0, u_1\} \in A_2$, then $\lim_{t \rightarrow \infty} E_2[u, u_t] = 0$.

Before proving this theorem, we need a little notation. Let $T(t) : X \rightarrow X$, $X = H_0^1 \times L^2$, be the solution operator given by Theorem 3.2:

$$\{u(t), u_t(t)\} = T(t)\{u_0, u_1\}.$$

Let $\phi \in X$ denote one of the equilibria of (2.20) and let

$$W^s(\phi) = \left\{ \psi \in X \mid T(t)\psi \rightarrow \phi \text{ as } t \rightarrow \infty \text{ strongly in } X \right\}$$

denote its stable manifold. We will show that $W^s(\phi)$ is a set of first category in X . Hence the union of stable manifolds of all equilibria is a set of first category in X , from which, together with Proposition 4.2, the theorem will follow.

Recall that a set of first category is a countable union of nowhere dense sets. This result therefore implies that, apart from a meager set of initial data, solutions approach no equilibrium and do indeed minimize energy, realizing the second alternative of Proposition 4.2. As in the discussion above, we use the fact that $T(t)$ has the explicitly known finite dimensional invariant subspaces $X_N = \{\{u, v\} \mid \{u, v\} = \sum_{j=1}^N \{a_j, b_j\} \sin jx\}$, so that $\psi \in X_N$ if and only if $T(t)\psi \in X_N$. The eigenvalue computations of (2.23-27) show that $\phi = \{u_k^\pm, 0\}$ is linearly unstable in X_N for $N > k(> \sqrt{\alpha})$ and $\phi = \{0, 0\}$ is linearly unstable in X_N for $N > \sqrt{\alpha}$. The fact that the union of the stable manifolds forms a set of first category will follow from:

LEMMA 4.7 For any ϕ and N sufficiently large, $W^s(\phi) \cap X_N$ is of first category in X_N .

Proof: X_N is finite dimensional and so we may invoke the center-stable manifold theorem (Pliss [1964], Kelley [1967], Carr [1981]) to construct a locally invariant manifold $W_{N,\varepsilon}^s(\phi)$ in X_N , containing ϕ , such that if $\psi \in W^s(\phi) \cap X_N$, then for t sufficiently large, $T(t)\psi \in W_{N,\varepsilon}^s(\phi)$. But because X_N is finite dimensional and ϕ is linearly unstable in X_N , we may choose $W_{N,\varepsilon}^s(\phi)$ to be closed and nowhere dense. Now

$$W^s(\phi) \cap X_N = \bigcup_{m \geq 0} T(m)^{-1} W_{N,\varepsilon}^s(\phi)$$

and since $T(m)$ is a homeomorphism on X_N , $T(m)^{-1} W_{N,\varepsilon}^s(\phi)$ is also closed and nowhere dense for each m and consequently $W^s(\phi) \cap X_N$ is of first category, as claimed. \square

Proof of Theorem 4.6 Let B_0 be a closed ball containing ϕ in its interior. B_0 may be chosen so small that ϕ is the only equilibrium point in B_0 (since equilibria are isolated), and $\|u_x\| < 1$ for $u \in B_0$ (using (2.25)). Define

$$W^s(\phi, B_0) = \{\psi \in B_0 \mid T(t)\psi \in B_0 \text{ for all } t > 0\}.$$

By continuous dependence, this set is clearly closed, and by Proposition 4.2, it follows that $W^s(\phi, B_0) \subset W^s(\phi)$, so that $W^s(\phi, B_0)$ defines a local stable manifold for ϕ , and

$$W^s(\phi) = \bigcup_{m \geq 1} T(m)^{-1} W^s(\phi, B_0)$$

is the union of closed sets. We claim that for each m , $T(m)^{-1} W^s(\phi, B_0)$ is nowhere dense. Suppose instead that this set contains some open ball B . Since $\bigcup_{N=1}^{\infty} X_N$ is dense in X , we may choose N as large as desired so that $B \cap X_N$ is an open nonempty set in X_N . But then $B \cap X_N$ is contained in $W^s(\phi) \cap X_N$, contradicting Lemma 4.7. This establishes the claim and $W^s(\phi)$ is a set of first category because $\bigcup_{M \geq 1} T(M)^{-1} W^s(\phi, B_0)$ is the countable union of nowhere dense sets. Taking the countable union of stable manifolds of all equilibria $\{u_k^{\pm}, 0\}$ delivers the desired set A_1 of the theorem. That A_1 is dense follows from the density of $\bigcup_{N=1}^{\infty} X_N$. The properties of A_2 , the complement of A_1 , follow directly. \square

This is a striking result. Arbitrary initial data in X can be approximated as closely as we wish by data in A_1 or A_2 , but the asymptotic behavior of the resulting solutions differs utterly in the strong topology. The numerical simulations of Section 6, which can of course only realize data in A_1 , nonetheless illustrate this

fact in their suggestion of a “crossover time” after which a solution started in A_1 settles towards a classical equilibrium, while one started arbitrarily close but in A_2 continues to explore a minimizing sequence. The asymptotics of this process are derived in Section 5.

4.3 Model 3 also Develops Fine Structure

Equation (2.5) shares many features of the second model, equation (2.4), including, as we have seen, its countable set of unstable equilibria. While we have not included detailed existence and uniqueness results for this pseudo-parabolic problem, since our main concern is with “mechanical” systems having an inertial driving term u_{tt} , it is perhaps of interest to consider its asymptotic behavior. For a related “local” problem, see Novick–Cohen and Pego [1989].

Inverting the operator $I - \beta(\partial^2/\partial x^2)$, equation (2.5) with boundary conditions (2.4b) can be written as

$$\beta u_t = -u(\|u_x\|^2 - 1) + \left(I - \beta \frac{\partial^2}{\partial x^2}\right)^{-1} u(\|u_x\|^2 - 1 - \alpha\beta), \quad (4.26)$$

and considered as an ODE on H_0^1 . It may be shown that solutions are smooth in t and exist globally for $t \geq 0$, so that the identity (2.8) makes sense for the energy E_3 of (2.7). As (2.29-30) show, the equilibria are all linearly unstable and the Galerkin projection (2.22) reveals that each N -dimensional subspace $X_N = \text{span}\{\sin jx\}_{j=1}^N \subset H_0^1$ is invariant under the flow generated by (4.26). Since the dynamics of each individual mode is now one dimensional, the characterization of $\bigcup_{N=1}^{\infty} X_N$, which is dense in H_0^1 , is somewhat simpler than for Model 2. Specifically, we have

THEOREM 4.8 Consider equation (2.5) with initial data $u(x, 0) = u_0$:

a) Suppose u_0 can be expressed as a finite Fourier sine series

$$u_0 = \sum_{j=1}^N a_j \sin jx, \quad a_N \neq 0, \quad (4.27)$$

then, if $N^2 \leq \alpha$, $u(x, t) \rightarrow 0$ strongly in H_0^1 while if $N^2 > \alpha$, $u(x, t) \rightarrow u_N^\pm$ if $a_N > 0$ or $a_N < 0$ respectively.

b) For any initial data with infinitely many nonzero Fourier coefficients, $u(x, t) \rightarrow 0$ weakly in H_0^1 and minimizes energy as it does so.

Proof: The eigenvalue calculations of (2.29)–(2.30) and the observations regarding the Galerkin projection (2.22) show that each subspace $X_N = \text{span}\{\sin jx\}_{j=1}^N$ is invariant and equal to the tangent space of

the stable manifolds of u_N^+ and u_N^- , the equilibria of (2.20). Thus X_N contains the entire stable manifolds of u_N^\pm . From (2.22) we see that no coefficient $a_j(t)$ can change sign, for if $a_j = 0$ then $\dot{a}_j = 0$; hence these manifolds are explicitly given by

$$W^s(u_N^\pm) = \left\{ u_0 \mid u_0 = \sum_{j=1}^N a_j \sin jx \text{ with } \pm a_n > 0 \right\}. \quad (4.28)$$

Otherwise, from (2.29), if $\alpha < 1$ $W^s(0) = \emptyset$ and, if $0 < N^2 \leq \alpha < (N+1)^2$, $u \equiv 0$ is the only equilibrium in X_N , so $W^s(0) = X_N$. This proves part (a).

For part (b) we proceed as in the proof of Proposition 4.2, observing that, from the energy E_3 (2.7) and the identity (2.8):

$$E_3(t) \rightarrow E_\infty \text{ as } t \rightarrow \infty \quad (4.29)$$

and

$$\|u_x\| + \int_0^t \{ \|u_t\|^2 + \beta \|u_{xt}\|^2 \}(s) ds \leq C, \quad (4.30)$$

for some C determined by the initial data. From (2.8) one concludes that $\int_0^\infty \{ \|u_t\|^2 + \beta \|u_{xt}\|^2 \}(s) < \infty$; the fact that, since we have an evolution equation in H_0^1 , $\|u_t\|^2$ and $\|u_{xt}\|^2$ have bounded time derivatives, therefore implies that

$$\|u_t(t)\| + \|u_{xt}(t)\| \rightarrow 0 \text{ as } t \rightarrow \infty. \quad (4.31)$$

However, we compute

$$\begin{aligned} \frac{d}{dt} \left(\frac{1}{2} \|u\|^2 + \frac{\beta}{2} \|u_x\|^2 \right) &= (u, u_t) + \beta (u_x, u_{xt}) \\ &= \left(u, [(\|u_x\|^2 - 1)u_{xx} - \alpha u + \beta u_{xxt}] \right) - \beta (u, u_{xxt}) \\ &= -(\|u_x\|^2 - 1)\|u_x\|^2 - \alpha \|u\|^2 \\ &= \frac{1}{2} - 2E_3(t) - \frac{1}{2} \|u_x\|^4, \end{aligned} \quad (4.32)$$

and this quantity must approach zero as $t \rightarrow +\infty$ in view of (4.31). Thus $0 \leq E_\infty \leq \frac{1}{4}$ and

$$\|u_x(t)\|^2 \rightarrow \sqrt{1 - 4E_\infty} \quad \text{and} \quad \frac{\alpha}{2} \|u(t)\|^2 \rightarrow \frac{1}{2} (\sqrt{1 - 4E_\infty} - 1 + 4E_\infty) \quad (4.33)$$

as $t \rightarrow \infty$, the latter from examination of E_3 , equation (2.7).

From the Galerkin projection (2.22) and the hypothesis that there are infinitely many nonzero a_j satisfying

$$\lim_{t \rightarrow \infty} \frac{\dot{a}_j(t)}{a_j(t)} = \frac{j^2 \left(1 - \frac{\alpha}{j^2} - \sqrt{1 - 4E_\infty}\right)}{1 + \beta j^2}, \quad (4.34)$$

and since a_j remains bounded for each j ($\|u\|^2 = \sum a_j^2$), we must have $\sqrt{1 - 4E_\infty} > 1 - \frac{\alpha}{j^2}$ for infinitely many j . Hence $E_\infty = 0$ and $\|u\|^2 \rightarrow 0$, $\|u_x\|^2 \rightarrow 1$ as $t \rightarrow +\infty$. This concludes the proof of part (b). \square

Remarks: Equation (2.5) written as

$$\left(I - \beta \frac{\partial}{\partial x^2}\right) u_t = (\|u_x\|^2 - 1) u_{xx} - \alpha u \quad (4.35)$$

is a gradient dynamical system for the energy

$$E_3[u] = \frac{1}{4} (\|u_x\|^2 - 1)^2 + \frac{\alpha}{2} \|u\|^2 \quad (4.36)$$

in $X = H_0^1$ equipped with the inner product

$$\langle u, v \rangle = (u, v) + \beta (u_x, v_x). \quad (4.37)$$

Novick-Cohen and Pego [1990] have considered a related “local” gradient system of the form

$$u_t = \Delta(f(u) + \nu u_t) \quad (4.38)$$

with nonmonotonic f and shown that global minimization typically fails to occur in this case.

4.4 Jumps do not Move

Theorem 3.3 shows that equilibrium solutions of Model 1 having discontinuous strain can be exponentially (dynamically) stable in an appropriate norm, while Theorem 4.1 shows that the final equilibrium state of a typical process governed by this model *never* minimizes energy globally. There are several open questions (cf. the Remarks of Section 4.1). Theorem 4.10 below gives a little more information. In particular, it implies that jumps in the initial data for u_x cannot disappear or move in finite time, nor can new jumps be created in finite time.

Since we only have $u_x \in L^\infty$ from Theorems 3.1-2 and we want to use the ODE for q much as in the global existence proofs, we need to define a notion of pointwise continuity for an L^∞ function. We do this in terms of bounded representatives of such functions.

Definition 4.9 For any $f \in L^\infty$ we will call f^* a bounded representative of f if f^* is a pointwise-defined and bounded measurable function belonging to the equivalence class f . Let $f \in L^\infty([0, \pi], \mathbb{R})$. We will call f *essentially continuous* at the point $x_0 \in [0, \pi]$ if there exists a bounded representative $f^* \in f$ that is continuous at x_0 and we will call it *essentially discontinuous* at $x_0 \in [0, \pi]$ if it is not essentially continuous there.

Much as in Pego [1987], we can use the ODE interpretation of the q component of the solution to show that essential discontinuities present in $q(t_0)$ (i.e. u_x) for any $t_0 \geq 0$ cannot be created or destroyed in finite positive time and so are unable to migrate into a region of essential continuity in u_x . This is an interesting characteristic of an ODE coupled to a parabolic PDE (cf. Hoff and Smoller [1985]).

THEOREM 4.10 Persistence of Strain Discontinuities: Let $\{u, u_t\}$ be a strong solution to (2.2) or (2.4) with initial data $\{v_0, u_1\} \in W^{1,\infty} \times L^2$. Then, if for any $t_0 \geq 0$, x_0 is a point of essential continuity of $u_x(t_0)$, it will remain so for all $t > t_0$. Likewise, if x_0 is a point of essential discontinuity of $u_x(t_0)$, it will remain so for all $t > t_0$.

Proof: Theorems 3.1(a) and 3.2(b) guarantee the existence of a unique solution

$$\{u, u_t\} \in C([0, \infty), W_0^{1,\infty} \times L^2) \cap C^1((0, \infty), W_0^{1,\infty} \times C)$$

or

$$\{p, q\} \in C^1((0, \infty), H_a^1) \times C^1((0, \infty), L^\infty)$$

for equations (2.2) and (2.4) respectively. As in the proofs of 3.1(a) and 3.2(b) we write the evolution of the q component as an ODE in the forms

$$q_t = -\sigma((p+q)/\beta) + e_1 \tag{3.14}$$

and

$$q_t = (1 - \|u_x\|^2)q/\beta + e_2 \tag{3.19}$$

with e_1 and e_2 as before. We know that e_1, e_2 and $p \in C^1((0, \infty), C)$ and that $q \in C^1((0, \infty), L^\infty)$. Since $\beta u_x = p + q$ and $p \in H_a^1$ for $t \geq 0$, it follows that a point of essential continuity (resp. discontinuity) of

$u_x(t \geq 0)$ corresponds to a point of essential continuity (resp. discontinuity) of q . For any $t_0 \geq 0$, let $q_0^* \in q(t_0)$ be a bounded representative of $q(t_0)$. As before, let $q^*(x, t)$ denote the unique solution at each x of the respective ODE satisfying $q^*(x, t_0) = q^*(t_0)$. As was shown in the global existence proofs, $q^*(x, t)$ is bounded for all $t \geq t_0$ and by uniqueness of q in L^∞ we must have that $q^*(\cdot, t) \in q(t)$ for all $t \geq t_0$. To prove the theorem, we therefore only need to show that, if x_0 is a point of continuity (or discontinuity) of q_0^* , then it must remain so for all $t \geq t_0$. Now assume that q_0^* is continuous at x_0 , i.e. for any sequence $x_n \rightarrow x_0$, $q_0^*(x_n) \rightarrow q_0^*(x)$ as $n \rightarrow \infty$. Viewing x as a parameter on which solutions of the ODE depend, it follows from continuous dependence of the solution on initial data and parameters that $q^*(x_n, t) \rightarrow q^*(x, t)$ as $n \rightarrow \infty$ for any $t > t_0$. Therefore $q^*(x, t)$ cannot develop a discontinuity at (x_0, t) for $t \geq t_0$.

On the other hand, if q_0^* is discontinuous at x_0 and we assume that for some $t_1 > t_0$, $q^*(x, t_1)$ is continuous at x_0 , then running the ODE backwards leads to a violation of continuous dependence on x of the data at t_1 , yielding a contradiction and completing the proof. \square

4.5 Decay of strain rates for Model 2

In Section 5 it will be useful to have more information regarding the asymptotic behavior of the strain rate and its time derivative for weak solutions of Model 2:

PROPOSITION 4.11 Suppose $\{u, u_t\}$ is a weak solution of (2.4) as given by Theorem 3.2a. Then as $t \rightarrow \infty$ we have

$$\|u_{xt}\| \rightarrow 0 \quad \text{and} \quad \|u_{xtt}\| \rightarrow 0.$$

Proof. From the transformation (3.4) used in the proof of Theorem 3.2a, $\beta u_{xt} = p_t + q_t$, so it suffices to show that $\|z_t\|, \|z_{tt}\| \rightarrow 0$ as $t \rightarrow \infty$, where $z = (p, q)$. Recall (3.9₂): $z_t + Az = f_2(z)$ where f_2 is smooth on $X = L_a^2 \times L_a^2$. Since the solution z is globally bounded in $X^{1/2}$ for $t \geq 0$, $f_2(z)$ is globally bounded and we may apply Lemma 4.3 of Pego [1987] to obtain, for $t \geq 0$, $\alpha = \frac{1}{2}$,

$$\|z_t(t+1)\| \leq C \left(\|z(t)\|_\alpha + \sup_{0 \leq s \leq 1} \|f_2(z(t+s))\| \right) \leq C. \quad (4.39)$$

Now, Corollary 3.4.6 of Henry [1981] implies that z is smooth in t for $t > 0$, with $z \in C^\infty((0, \infty), X)$ and

that $Z = z_t$ satisfies, for $t > 0$,

$$Z_t + AZ = g(z)Z, \quad (4.40)$$

where, with $\beta w = p + q = \{1, 1\} \cdot z$ and $\beta W = \{1, 1\} \cdot Z$,

$$g(z)Z = \left[(\|w\|^2 - 1)W - \alpha BW + 2w \int_0^\pi w(x)W(x)dx \right] \{1, -1\}.$$

Since $\|z\|, \|z_t\| \leq C$ for $t \geq 1$, we obtain the estimate, for $1 \leq t \leq s$,

$$\|g(z(t))Z(t) - g(z(s))Z(s)\| \leq C(K(t)|t - s| + \|Z(t) - Z(s)\|),$$

where $K(t) = \sup_{s \geq t} \|z_t(s)\|$. We may therefore apply Lemma A.3 of Pego [1987] to equation (4.40), with $\alpha = 0$, to conclude that for $t \geq 1$,

$$\|Z_t(t+1)\| \leq C(\|Z(t)\| + K(t) + \sup_{0 \leq s \leq 1} \|Z(t+s)\|) \leq CK(t). \quad (4.41)$$

This bound implies that $t \mapsto \|u_{xt}\|^2$ is Lipschitz for $2 \leq t < \infty$ and hence that $\|u_{xt}\| \rightarrow 0$, since $\int_0^\infty \|u_{xt}(t)\|^2 dt < \infty$. This yields the first claim of the proposition.

Now, we have $\beta\|u_{xt}\| = \|p_t + q_t\| \rightarrow 0$. Proposition 4.2 implies that $\|f_2(z)\| \rightarrow 0$ as $t \rightarrow \infty$ (cf. 3.7₂), which yields $\|q_t\| \rightarrow 0$ using (3.6₂). Hence as $t \rightarrow \infty$, we have $\|Z_t\| \rightarrow 0$, so $K(t) \rightarrow 0$ and (4.41) implies that $\|z_t\| \rightarrow 0$. But $\beta u_{xtt} = \{1, 1\} \cdot Z_t$, so the proposition is proved. \square

5. ASYMPTOTICS OF MODEL 2: ENERGY TRANSPORT TO HIGH WAVENUMBERS

Theorem 4.6 establishes that almost all solutions of equation (2.4) do minimize energy. We now wish to investigate in more detail how this occurs. As the second alternative of Proposition 4.2 is realized, and $\|u\| \rightarrow 0$, $\|u_x\| \rightarrow 1$, what do solutions look like? How does the fine structure, which evidently must result, develop from and depend on the initial data? At what rate does the process of refinement proceed? In this and the next section we attempt answers to such questions. Our main result is most conveniently stated in terms of the Galerkin projection written for the Fourier components $b_k = ka_k$ of the strain,

$$u_x = \sum_{k=1}^{\infty} b_k \sqrt{\frac{2}{\pi}} \cos kx, \quad (5.1)$$

specifically:

$$\begin{aligned} \dot{b}_k &= c_k \\ \dot{c}_k &= k^2 \left[\left(1 - \frac{\alpha}{k^2} - \sum_1^{\infty} b_j^2 \right) b_k - \beta c_k \right], \quad k = 1, 2, \dots \end{aligned} \quad (5.2)$$

5.1 Modal Dynamics of Model 2

THEOREM 5.1 *Assume that the second alternative of Proposition 4.2 holds and pick any $\nu > 0$ and $K < \infty$.*

Then there exists $T = T(\nu, K, \alpha, \beta) < \infty$ such that, for all $t \geq T$ and $k \leq K$ the solutions of (5.2) satisfy

$$|\{b_k, c_k\}(t)| \leq \nu \text{ and } \left| 1 - \sum_1^\infty b_k^2 \right| \leq \nu^2. \quad (5.3)$$

Moreover, for all $k \neq l$ with $k, l > K$ and $t \geq T$, the modal ratio $\rho_{kl} = b_k/b_l$ satisfies

$$\rho_{kl}(t) = e^{\frac{\alpha}{\beta} \left(\frac{1}{l^2} - \frac{1}{k^2} \right) \mu_{k,l}(t-T)} \rho_{kl}(T) \quad (5.4)$$

where $\mu_{k,l}(s) = s(1 + O(1/K^2) + O(l^2/k^2 K^2))$.

This result shows that any specific Fourier mode b_l eventually dies and it describes how energy escapes to $k = \infty$. In fact, for $k \geq l > K$, equation (5.4) shows that high modes grow exponentially at the expense of low modes and, since each b_k remains bounded, this implies that every mode eventually decays at an exponential rate. We will use this to determine the asymptotic fates of various sorts of initial data.

The proof of Theorem 5.1 is rather long, so to illustrate the main idea we first give a formal derivation of the linear ODE from which (5.4) is derived. Since $\|u\|^2 = \sum_1^\infty (b_k^2/k^2)$ and $\|u_t\|^2 = \sum_1^\infty (c_k^2/k^2) \rightarrow 0$ (equations (4.19), (4.16)) we conclude that, after sufficient time has elapsed $|b_k(t)|$ and $|c_k(t)|$ are small for low k and the behavior of (5.2) is dominated by the high mode equations, $k > K$. In this situation, each pair of equations forms a singularly perturbed system and since $\|u_{xtt}\|^2 = \sum_1^\infty c_k^2 \rightarrow 0$ by Proposition 4.11, we conclude that, as $t \rightarrow \infty$,

$$c_k = \frac{1}{\beta} \left(1 - \frac{\alpha}{k^2} - \sum b_j^2 \right) b_k + \frac{1}{k^2} o(1); \quad (5.5)$$

i.e. solutions rapidly approach and thereafter lie within a boundary layer near a slow manifold. Replacing c_k in the first component of (5.2) by (5.5) and ignoring the error term, we formally obtain the reduced equations

$$\dot{b}_k = \frac{1}{\beta} \left(1 - \frac{\alpha}{k^2} - \sum b_j^2 \right) b_k, \quad k = K, K+1, \dots \quad (5.6)$$

Now let $\rho_{kl} = b_k/b_l$ and compute

$$\dot{\rho}_{kl} = \frac{\dot{b}_k b_l - b_l \dot{b}_k}{b_l^2} = \frac{\left(1 - \frac{\alpha}{k^2} - \sum b_j^2 \right) b_k b_l - \left(1 - \frac{\alpha}{l^2} - \sum b_j^2 \right) b_l b_k}{\beta b_l^2} = \frac{\alpha}{\beta} \left(\frac{1}{l^2} - \frac{1}{k^2} \right) \rho_{kl}, \quad (5.7)$$

which yields (5.4), with $\mu_{k,l}(s) = s$.

Before justifying this calculation, we observe that (5.6) can also be formally derived by ignoring u_{tt} in (2.4) or, alternatively, by considering the asymptotic equation

$$q_t = -\mathcal{F}_2((p+q)/\beta)$$

from (3.6₂) and using the fact that $\|p\| \rightarrow 0$. Note that, in the limit, $q \approx \beta u_x = \beta \sum b_k \sqrt{\frac{2}{\pi}} \cos kx$.

We also observe that, integrating (5.6) yields $b_k(t) = b_k(0)e^{-\alpha t/\beta k^2}/D(t)$, where

$$\begin{aligned} D(t)^2 &= \exp\left(2 \int_0^t \frac{1}{\beta}(-1 + \sum b_j^2(s))ds\right) \\ &= \sum b_j(0)^2 e^{-2\alpha t/\beta j^2} / \sum b_j(t)^2. \end{aligned}$$

If we suppose that $\|u_x\|^2 = \sum b_j(t)^2 \rightarrow 1$ as $t \rightarrow \infty$ (cf. Proposition 4.2), then

$$b_k(t) \approx \frac{b_k(0)e^{-\alpha t/\beta k^2}}{(\sum b_j(0)^2 e^{-2\alpha t/\beta j^2})^{\frac{1}{2}}} \quad (5.8)$$

A heuristic description of the evolution suggested by (5.8) is that components of the solution with wavenumbers $k < O(\sqrt{t})$ are rapidly suppressed, while components with $k \gg \sqrt{t}$ are synchronously amplified so as to normalize the solution so that $\|u_x\| \approx 1$. This suggests that the dynamics is sensitive to the initial data, in a manner reminiscent of the chaotic dynamics in the standard shift map on the space of semi-infinite sequences. This strong influence of initial data will be investigated further in section 5.2.

The main tool in the proof of Theorem 5.1 is

PROPOSITION 5.2 Let $0 < \varepsilon$, $\delta_1 \ll 1$, $\delta_2 \gg \delta_1$ and $\gamma_2 > \gamma_1 > 0$ be real parameters and consider the singularly perturbed linear problem

$$\begin{aligned} \dot{u} &= v \\ \dot{v} &= \frac{1}{\varepsilon}(a(t)u - b(t)v), \end{aligned} \quad (5.9)$$

where $|a(t)| \leq \delta_1$, $|\dot{a}(t)| \leq \delta_2$, $\gamma_1 \leq b(t) \leq \gamma_2$ and $|\dot{b}(t)| \leq \gamma_2$ for all t . Then (5.9) possesses a global, normally hyperbolic slow manifold $v = h(t, \varepsilon)u$ with h satisfying

$$\varepsilon(\dot{h} + h^2) = a(t) - b(t)h \quad (5.10a)$$

and

$$h(t, \varepsilon) = a(t)/b(t) + O(\varepsilon\delta_2/\gamma_1^2) + O(\varepsilon\delta_1\gamma_2/\gamma_1^3) \quad (5.10b)$$

for $t \geq T = O(\varepsilon \ln(1/\varepsilon\delta_2))$. Moreover, if $w(t)$ solves the reduced system

$$\dot{w} = h(t, \varepsilon)w \quad (5.11)$$

and $\{u(t), v(t)\}$ solves (5.9), then there exist constants $C, c > 0$ such that

$$|\{u(t), v(t)\} - \{w(t), h(t, \varepsilon)w(t)\}| \leq Ce^{-ct/\varepsilon}. \quad (5.12)$$

Proof: The proposition is essentially a special case of the global center manifold theorem of Fenichel [1979, Theorem 9.1], cf. Carr [1981, Section 2.7], but since we need sharper estimates on $h(t, \varepsilon)$ we sketch the proof. Let $t = \varepsilon\tau$, so that $\frac{d}{d\tau}(\cdot) \stackrel{\text{def}}{=} (\cdot)' = \varepsilon(\cdot)$ and (5.9) becomes, after adding a trivial component:

$$\left. \begin{aligned} u' &= \varepsilon v, & v' &= a(t)u - b(t)v, \\ t' &= \varepsilon, & \varepsilon' &= 0. \end{aligned} \right\} \quad (5.13)$$

For $\varepsilon = 0$ the linearization of (5.13) has the matrix

$$\begin{bmatrix} 0 & 0 & 0 & 0 \\ a(t) & -b(t) & \dot{a}(t)u - \dot{b}(t)v & 0 \\ 0 & 0 & 0 & 0 \\ 0 & 0 & 0 & 0 \end{bmatrix}$$

and the (global) manifold $v = a(t)u/b(t)$ is filled with equilibria, each of which has an eigenvector $(0, 1, 0, 0)^T$ with eigenvalue $-b(t) \geq -\gamma_1$. The usual center manifold theorem ensures existence of a *local* manifold $v = g(u, t, \varepsilon)$ tangent to $u = t = \varepsilon = 0$ at $(0, 0, 0, 0)$ and Fenichel's results show that the manifold is, in fact, globally defined in u and t .

For our system, linear in u, v , we may take $g(u, t, \varepsilon) = h(t, \varepsilon)u$. To see this and derive (5.10a,b), we differentiate $v = hu$ with respect to τ and substitute from (5.13):

$$\begin{aligned} v' &= \frac{\partial h}{\partial t} t' u + \frac{\partial h}{\partial \varepsilon} \varepsilon' u + h u' = \varepsilon \dot{h} u + h \varepsilon v \\ &= \varepsilon(\dot{h} + h^2)u. \end{aligned} \quad (5.14a)$$

The second component of (5.13) gives

$$v' = au - bv = (a - bh)u \quad (5.14b)$$

and equating (5.14a,b) gives (5.10a). To obtain (5.10b) we integrate (5.10a):

$$\dot{h} + \frac{b(t)}{\varepsilon} h = \frac{a(t)}{\varepsilon} - h^2$$

to yield

$$h(t) = e^{-B(t)/\varepsilon} h(0) + e^{-B(t)/\varepsilon} \int_0^t e^{B(s)/\varepsilon} \left(\frac{a(s)}{\varepsilon} - h^2(s) \right) ds, \quad (5.15)$$

where

$$\gamma_1 t \leq B(t) = \int_0^t b(\tau) d\tau \leq \gamma_2 t.$$

Now the integrand of (5.15) may be written as

$$\frac{b(s)}{\varepsilon} e^{B(s)/\varepsilon} \left(\frac{a(s) - \varepsilon h^2(s)}{b(s)} \right)$$

and integration by parts employed to yield

$$h(t) = e^{-B(t)/\varepsilon} \left[h(0) - \frac{a(0) - \varepsilon h^2(0)}{b(0)} \right] + \frac{a(t) - \varepsilon h^2(t)}{b(t)} - e^{-B(t)/\varepsilon} \int_0^t e^{B(s)/\varepsilon} F(\varepsilon, s) ds, \quad (5.16)$$

where

$$F(\varepsilon, s) = \left(\frac{(\dot{a} - 2\varepsilon h\dot{h})}{b} - \frac{\dot{b}(a - \varepsilon h^2)}{b^2} \right) (s).$$

To estimate terms in (5.16) we first observe that, since

$$\dot{h} = \frac{a - bh}{\varepsilon} - h^2, \quad (5.17)$$

with $|a| \leq \delta_1$, $b \geq \gamma_1$, the interval $(-K_1\delta_1/\gamma_1, K_1\delta_1/\gamma_1)$ is positively invariant for (5.17) provided that $K_1 > 1 + O(\varepsilon\delta_1/\gamma_1^2)$. Thus, if $|h(0)| \leq K_1\delta_1/\gamma_1$, $|h(t)| < K_1\delta_1/\gamma_1$, for all $t > 0$. Furthermore, from (5.17)

$$|\varepsilon\dot{h}| = |a - bh - \varepsilon h^2| \leq \delta_1 + \gamma_2 \frac{K_1\delta_1}{\gamma_1} + \varepsilon \frac{K_1^2\delta_1^2}{\gamma_1^2}$$

and so, using $|a| \leq \delta_1$, $|\dot{a}| \leq \delta_2$, $|\dot{b}| \leq \gamma_2$ and $b \geq \gamma_1$, $F(\varepsilon, s)$ can be estimated by

$$|F(\varepsilon, s)| \leq \frac{\delta_2 + 2\frac{K_1\delta_1}{\gamma_1}(\delta_1 + \gamma_2 \frac{K_1\delta_1}{\gamma_1} + \varepsilon \frac{K_1^2\delta_1^2}{\gamma_1^2})}{\gamma_1} + \frac{\gamma_2(\delta_1 + \varepsilon \frac{K_1^2\delta_1^2}{\gamma_1^2})}{\gamma_1^2} \leq \frac{\delta_2 K_2}{\gamma_1} + \frac{\delta_1 \gamma_2 K_3}{\gamma_1^2}$$

for some $K_2 = 1 + O(\delta_1/\gamma_1)$. We therefore have, for the third term in (5.16):

$$\left| \int_0^t e^{-(B(t)-B(s))/\varepsilon} F(\varepsilon, s) ds \right| \leq \left(\frac{\delta_2 K_2}{\gamma_1} + \frac{\delta_1 \gamma_2 K_3}{\gamma_1^2} \right) \int_0^t e^{-\int_s^t b(\tau)/\varepsilon d\tau} ds$$

$$\leq \left(\frac{\delta_2 K_2}{\gamma_1} + \frac{\delta_1 \gamma_2 K_3}{\gamma_1^2} \right) \int_0^t e^{-\gamma_1(t-s)/\epsilon} ds \leq \frac{\epsilon}{\gamma_1^2} \left(\delta_1 K_2 + \frac{\delta_1 \gamma_2 K_3}{\gamma_1} \right) (1 - e^{-\gamma_1 t/\epsilon}). \quad (5.18)$$

Now (5.18) and the fact that $|\epsilon h^2(t)/b(t)| \leq \epsilon K_1^2 \delta_1^2 / \gamma_1^3$ imply that, if we pick $t \sim \epsilon \ln(1/\epsilon \delta_2)$ large enough so that the first term in (5.16) is $O(\epsilon \delta_2)$ we have the estimate

$$h(t) = \frac{a(t)}{b(t)} + O(\epsilon \delta_2 / \gamma_1^2) + O(\epsilon \delta_1 \gamma_2 / \gamma_1^3), \quad (5.10b)$$

as claimed.

Finally, exponential attraction of solutions towards $v = g(t, \epsilon)u$ follows from the fact that when $\epsilon = 0$ the manifold $v = \frac{a(t)}{b(t)}u$ attracts solutions at the rate γ_1 in the “fast” time τ , cf. Fenichel [1979]. \square

Proof of Theorem 5.1 Since $\|u\|^2 = \sum_1^\infty a_j^2 = \sum_1^\infty \frac{b_j^2}{j^2} \rightarrow 0$ and $\|u_t\|^2 = \sum_1^\infty \dot{a}_j^2 = \sum_1^\infty \frac{c_j^2}{j^2} \rightarrow 0$ and $\|u_x\|^2 = \sum_1^\infty b_j^2 \rightarrow 1$ as $t \rightarrow \infty$ we may pick $T(\nu, K)$ large enough so that $\|u\|^2, \|u_t\|^2 < \nu^2 / 2K^2$ for $t \geq T$, in which case

$$|\{b_k, c_k\}(t)|^2 = b_k^2 + c_k^2 \leq k^2 \sum_1^\infty \left(\frac{b_j^2}{j^2} + \frac{c_j^2}{j^2} \right) \leq \frac{k^2 \nu^2}{K^2} \leq \nu^2,$$

for $k \leq K$. Possibly by taking T larger, we can also guarantee that $|1 - \sum_1^\infty b_k^2| \leq \nu^2$. This proves the first claim (5.3) and enables us to focus on the modal equations (5.2) for $k > K$.

We shall derive an exact second order equation for the modal ratio ρ_{kl} . Computing

$$\dot{\rho}_{kl} = \frac{\dot{b}_k b_l - b_l \dot{b}_k}{b_l^2}$$

and using

$$\dot{b}_k = \frac{1}{\beta} \left[\left(1 - \frac{\alpha}{k^2} - \sum b_j^2 \right) b_k - \ddot{b}_k / k^2 \right]$$

from (5.2), we obtain

$$\dot{\rho}_{kl} = \frac{\alpha}{\beta} \left(\frac{1}{l^2} - \frac{1}{k^2} \right) \rho_{kl} + \frac{1}{\beta b_l^2} \left(\frac{b_k \ddot{b}_l}{l^2} - \frac{b_l \ddot{b}_k}{k^2} \right). \quad (5.19)$$

Differentiating $b_k = b_l \rho_{kl}$ we may express

$$\begin{aligned} b_l \ddot{b}_k &= b_l \ddot{b}_l \rho_{kl} + 2b_l \dot{b}_l \dot{\rho}_{kl} + b_l^2 \ddot{\rho}_{kl} \\ &= b_k \ddot{b}_l + 2b_l \dot{b}_l \dot{\rho}_{kl} + b_l^2 \ddot{\rho}_{kl} \end{aligned}$$

and rewrite the final term of (5.19) so that (5.19) becomes

$$\frac{1}{\beta k^2} \ddot{\rho}_{kl} + \left(1 + \frac{2\dot{b}_l}{\beta k^2 b_l} \right) \dot{\rho}_{kl} + \frac{1}{\beta} \left(\frac{1}{k^2} - \frac{1}{l^2} \right) \left(\alpha + \frac{\ddot{b}_l}{b_l} \right) \rho_{kl} = 0. \quad (5.20)$$

We will use Proposition 5.2 first to bound $\left|\frac{\dot{b}_l}{b_l}\right|$ and $\left|\frac{\ddot{b}_l}{b_l}\right|$ and then again to determine the asymptotics of (5.20). Consider the equations

$$\begin{aligned} \dot{b}_l &= c_l \\ \dot{c}_l &= l^2 \left[\left(1 - \frac{\alpha}{l^2} - \sum b_j^2\right) b_l - \beta c_l \right], \quad l = K+1, K+2, \dots \end{aligned} \quad (5.21)$$

and take $T(\alpha, K)$ large enough so that $|1 - \|u_x\|^2| = |1 - \sum b_j^2| \leq \frac{\alpha}{K^2}$ and $\left|\frac{d}{dt}(\sum b_j^2)\right| = |2(u_x, u_{xt})| \leq 2\|u_x\| \|u_{xt}\| \leq \frac{\alpha}{K^2}$, for some large K . The latter is possible since $\|u_{xt}\| \rightarrow 0$ as $t \rightarrow \infty$, by Proposition 4.11. Then (5.21) satisfies the hypotheses of Proposition 5.2 for each $l > K$, with $\varepsilon = 1/l^2$, $\delta_1 = \delta_2 = 2\alpha/K^2$ and $\gamma_1 = \gamma_2 = \beta$ and, after sufficient time ($O(1/l^2)$) has elapsed, we have, from (5.10b) and (5.11)

$$\left|\frac{\dot{b}_l}{b_l}\right| = |h(t, \varepsilon)| \leq \frac{\delta_1}{\gamma_1} + O(\varepsilon \delta_2 / \gamma_1^2) \leq \frac{2\alpha}{\beta K^2} + O\left(\frac{2\alpha}{\beta l^2 K^2}\right) \leq \frac{\alpha C_1}{2\beta K^2}, \quad (5.22)$$

for some C_1 . Also, differentiating $\dot{b}_l = hb_l$, we have

$$\ddot{b}_l = \dot{h}b_l + h\dot{b}_l = (\dot{h} + h^2)b_l,$$

or

$$\frac{\ddot{b}_l}{b_l} = \dot{h} + h^2 = \frac{a(t) - b(t)h}{\varepsilon}, \quad (5.23)$$

so that, from (5.10a,b)

$$\left|\frac{\ddot{b}_l}{b_l}\right| \leq \frac{O(\varepsilon \delta_2 \gamma_2 / \gamma_1^2)}{\varepsilon} = \frac{\alpha C_2}{\beta K^2}, \quad (5.24)$$

for some $C_2 > 0$.

We can now write (5.20) as

$$\ddot{\rho}_{kl} + k^2 [b(t)\dot{\rho}_{kl} - a(t)\rho_{kl}] = 0, \quad k, l > K, \quad (5.25a)$$

where

$$\beta - \frac{\alpha C_1}{\beta k^2 K^2} \leq b(t) = \beta + \frac{2}{k^2} \frac{\dot{b}_l}{b_l} \leq \beta + \frac{\alpha C_1}{\beta k^2 K^2}, \quad (5.25b)$$

and

$$a(t) = \left(\frac{1}{l^2} - \frac{1}{k^2}\right) \left(\alpha + \frac{\ddot{b}_l}{b_l}\right) = \alpha \left(\frac{1}{l^2} - \frac{1}{k^2}\right) \left(1 + O\left(\frac{1}{\beta K^2}\right)\right), \quad (5.25c)$$

so that

$$|a(t)| \leq \alpha C_3 \left| \frac{1}{l^2} - \frac{1}{k^2} \right| \quad (5.25d)$$

for some $C_j > 0$. To obtain bounds on the time derivatives we first observe that $|\dot{b}(t)| = \frac{2}{k^2} \left| \frac{d}{dt} \left(\frac{\dot{b}_l}{b_l} \right) \right|$ and

$$\left| \frac{d}{dt} \left(\frac{\dot{b}_l}{b_l} \right) \right| = \left| \frac{\ddot{b}_l}{b_l} - \frac{\dot{b}_l^2}{b_l^2} \right| \leq \frac{\alpha C_2}{\beta K^2} + \left(\frac{\alpha C_1}{2\beta K^2} \right)^2 \leq \frac{\alpha C_4}{2\beta K^2},$$

from (5.22) and (5.24). Thus, for (5.25a)

$$|\dot{b}(t)| \leq \frac{\alpha C_4}{\beta k^2 K^2}, \quad (5.25e)$$

for some C_4 . Finally, from (5.25c) $|\dot{a}| = \left| \left(\frac{1}{l^2} - \frac{1}{k^2} \right) \frac{d}{dt} \left(\frac{\dot{b}_l}{b_l} \right) \right|$ and, from the equation of motion (5.21)

$$\left| \frac{d}{dt} \left(\frac{\dot{b}_l}{b_l} \right) \right| = \left| \frac{d}{dt} l^2 \left[\left(1 - \frac{\alpha}{l^2} - \sum_1^\infty b_j^2 \right) - \beta \frac{\dot{b}_l}{b_l} \right] \right| \leq l^2 \left| 2 \sum_1^\infty b_j c_j + \beta \frac{d}{dt} \left(\frac{\dot{b}_l}{b_l} \right) \right|,$$

so that, using the a priori bound on $|\sum b_j \dot{b}_j| = |(u_x, u_{xt})|$ and that on $\frac{d}{dt} \left(\frac{\dot{b}_l}{b_l} \right)$ derived above, we have

$$|\dot{a}(t)| \leq \left(1 - \frac{l^2}{k^2} \right) \left(\frac{\alpha}{K^2} + \frac{\alpha C_4}{2K^2} \right) \leq \alpha C_5 \left(1 - \frac{l^2}{k^2} \right) / K^2, \quad (5.25f)$$

for some C_5 . Thus (5.25a) satisfies the hypotheses of Proposition 5.2 with $\varepsilon = 1/k^2$, $\delta_1 = \alpha C_3 \left| \frac{1}{l^2} - \frac{1}{k^2} \right|$, $\delta_2 = \alpha C_5 \left| 1 - \frac{l^2}{k^2} \right|$, $\gamma_1 = \beta - \alpha C_1 / \beta k^2 K^2$ and $\gamma_2 = \beta + \alpha(C_1 + C_4) / \beta k^2 K^2$.

We conclude from Proposition 5.2 that the solution $\rho_{kl}(t)$ of (5.25a) is close in the sense of (5.12) to that of the reduced equation

$$\dot{\rho}_{kl} = h(t, k, l) \rho_{kl}, \quad (5.26)$$

where

$$h(t, k, l) = \frac{\alpha \left(\frac{1}{l^2} - \frac{1}{k^2} \right) \left(1 + O\left(\frac{1}{K^2} \right) \right)}{\beta + O\left(\frac{1}{k^2 K^2} \right)} + O\left(\frac{\alpha}{k^2 K^2} \left| 1 - \frac{l^2}{k^2} \right| \right) + O\left(\frac{\alpha}{k^2} \left| \frac{1}{l^2} - \frac{1}{k^2} \right| \right),$$

or

$$h(t, k, l) = \frac{\alpha}{\beta} \left(\frac{1}{l^2} - \frac{1}{k^2} \right) \left(1 + O\left(\frac{l^2}{k^2 K^2} \right) + O\left(\frac{1}{K^2} \right) \right). \quad (5.27)$$

Integration of (5.26-7) yields the final statement (5.4) of the Theorem. Note that throughout the proof of Theorem 5.1, the constants C_j depend only on α and β but that the time T which must elapse before the various a priori estimates hold also depends on K and ν . \square

5.2 Influence of Initial Data on Modal Dynamics.

In view of Theorem 5.1, for any $\nu > 0$ and $K < \infty$ we may pick $T(\alpha, \beta, \nu, K)$ large enough so that

$$\left. \begin{aligned} \left| \sum_{k=1}^{\infty} b_k^2 - 1 \right| &\leq \nu^2 \\ \sum_{k=1}^{\infty} b_k^2 &\leq \sum_{k=K+1}^{\infty} b_k^2 + \nu^2 K. \end{aligned} \right\} \quad (5.28)$$

Thus, from the definition of $\rho_{ki}(t)$, we have

$$b_i^2(t) \sum_{K+1}^{\infty} \rho_{ki}^2(t) = \sum_{K+1}^{\infty} b_k^2(t) = 1 + O(\nu^2 K)$$

and so, from (5.4)

$$b_i^2(t) = (1 + O(\nu^2 K)) \left/ \sum_{K+1}^{\infty} \rho_{ki}^2(T) e^{\frac{2\alpha}{\beta} \left(\frac{1}{l^2} - \frac{1}{k^2}\right) \mu_{k,l}(t-T)} \right. \quad (5.29)$$

for $t \geq T$. Writing $s = t - T$ and recalling that $\mu_{k,l}(s) = s \left(1 + O\left(\frac{1}{K^2}\right) + O\left(\frac{l^2}{k^2 K^2}\right)\right)$, we may split terms in the sum of (5.29) to obtain

$$\begin{aligned} b_i^2(s+T) &= \frac{(1 + O(\nu^2 K)) b_i^2(T) e^{\frac{-2\alpha s}{\beta l^2} \left(1 + O\left(\frac{1}{K^2}\right)\right)}}{\sum_{K+1}^{\infty} b_k^2(T) e^{\frac{-2\alpha s}{\beta k^2} \left(1 + O\left(\frac{1}{K^2}\right) + O\left(\frac{l^2}{k^2 K^2}\right)\right) + \frac{2\alpha s}{\beta l^2} O\left(\frac{l^2}{k^2 K^2}\right)}} \\ &= \frac{(1 + O(\nu^2 K)) b_i^2(T) e^{\frac{-2\alpha s}{\beta l^2} \left(1 + O\left(\frac{1}{K^2}\right)\right)}}{\sum_{K+1}^{\infty} b_k^2(T) e^{\frac{-2\alpha s}{\beta k^2} \left(1 + O\left(\frac{1}{K^2}\right) + O\left(\frac{l^2}{k^2 K^2}\right)\right)}}, \end{aligned}$$

or

$$b_i^2(s+T) = \frac{b_i^2(T) e^{\frac{-2\alpha s}{\beta l^2}}}{D(\alpha, \beta, \nu, K, T, l, s)}, \quad (5.30)$$

where, if T is taken large enough so that ν and $1/K^2$ are small, we have D as close as we wish to

$$D_{\infty} = \sum_{K+1}^{\infty} b_k^2(T) e^{\frac{-2\alpha s}{\beta k^2}}$$

for all l for which $O(l^2/k^2 K^2) < Cl^2/K^4$ is small. This permits us to explore the behavior of the ‘‘modal energy’’ $b_i^2(t)$ over a (finite) range of wavenumbers starting at K and ending at, say, K^2/C . In fact, since D_{∞} decays monotonically with s (or t), the wavenumber spectrum $b_i^2(t)$ is maximized for fixed $t > T$ at $l_{\max}(t)$ satisfying

$$\frac{d}{dl} \left(b_i^2(T) e^{-2\alpha s/\beta l^2} \right) = 0$$

or

$$s = t - T = -\frac{\beta l^3 b_i'(T)}{2\alpha b_i(T)}. \quad (5.31)$$

We give two examples. Suppose first that the initial data is analytic, and more specifically that at time T the coefficients b_l satisfy

$$b_l(T) = A e^{-cl} \quad (5.32)$$

for some $A, c > 0$. Substitution of (5.32) into (5.31) yields

$$l_{\max}(s+T) = \left(\frac{2\alpha s}{\beta c}\right)^{1/3}. \quad (5.33)$$

Thus, as $t \rightarrow \infty$ the peak of the energy in wavenumber space moves out to $k = \infty$ at the rate $(\frac{t-T}{c})^{1/3}$ and, since $\sum_1^\infty b_l^2 \rightarrow 1$, the area under the modal energy curve b_l^2 vs. k converges to 1: see Figure 3. We next ask how this ‘‘bump’’ behaves in wavenumber space as $t \rightarrow \infty$; does it concentrate or spread out? To answer this we compute the half power bandwidth $B(t) = l_b - l_a$ where l_b, l_a satisfy

$$b_l^2(T)e^{\frac{-2\alpha s}{\beta l^2}} = \left(\frac{1}{2}b_l^2(T)e^{\frac{-2\alpha s}{\beta l^2}}\right)\Big|_{l=l_{\max}(s)}. \quad (5.34)$$

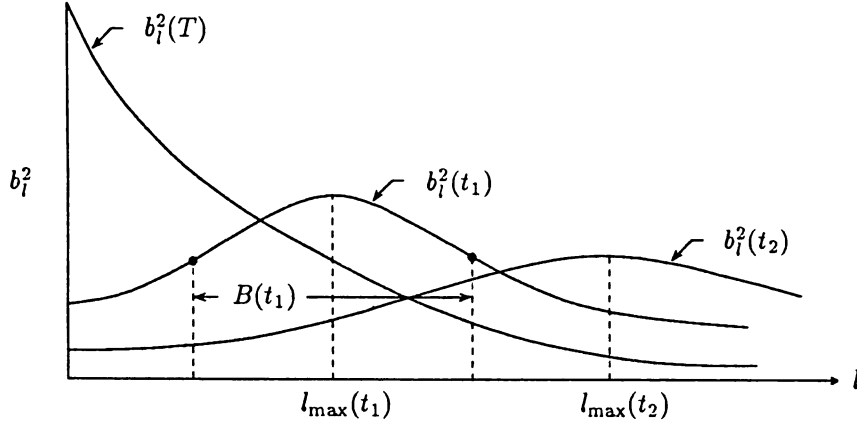

Figure 3 Evolution of modal energies.

Substituting (5.32)–(5.33) into (5.34), we have

$$e^{-2\left(\frac{cl + \frac{\alpha s}{\beta}}{\beta l^2}\right)} = \frac{1}{2}e^{-2\left(\frac{cl_{\max} + \frac{2\alpha s}{\beta l_{\max}^2}}{\beta l_{\max}^2}\right)},$$

or, after some rearrangement

$$l^3 - \left(\frac{1}{2c} \ln 2 + (2^{1/3} + 2^{-2/3})\left(\frac{\alpha s}{\beta c}\right)^{1/3}\right)l^2 + \frac{\alpha s}{\beta c} = 0. \quad (5.35)$$

To estimate the two relevant roots l_a, l_b of (5.35) we let $l = l_{\max} + m$ and expand about the peak and neglect terms of $O(m^3)$. Solution of the resulting quadratic equation in m yields

$$B(s+t) = l_a - l_b \approx m_a - m_b = \frac{2\left(\frac{3}{c} \ln 2 \left(\frac{2\alpha s}{\beta c}\right)\right)^{1/2}}{\left(3\left(\frac{2\alpha s}{\beta c}\right)^{1/3} - \frac{1}{c} \ln 2\right)} \sim 2\left(\frac{\ln 2}{3c}\right)^{1/2} \left(\frac{2\alpha s}{\beta c}\right)^{1/6},$$

for large $s = t - T$. Thus, while the peak $l_{\max}(t)$ moves to infinity at the rate

$$l_{\max}(t) = \left(\frac{2\alpha(t-T)}{\beta c} \right)^{1/3} \sim \left(\frac{t}{c} \right)^{1/3}, \quad (5.36a)$$

the bandwidth spreads like

$$B(t) \sim 2 \left(\frac{\ln 2}{3c} l_{\max}(t) \right)^{1/2} \sim \frac{t^{1/6}}{c^{2/3}}. \quad (5.36b)$$

For the second example, suppose that

$$b_l(T) = Al^{-r}, \quad (5.37)$$

so that u is C^{r-1} . In this case (5.31) yields

$$l_{\max}(s+T) = \left(\frac{2\alpha s}{\beta r} \right)^{1/2} \quad (5.38)$$

and, from (5.34) and (5.37–8), the half power points are given by

$$l^{-2r} e^{-\frac{2\alpha l}{\beta l^2}} = \frac{1}{2} \left(\frac{\beta r}{2\alpha s} \right)^r e^{-r}. \quad (5.39)$$

Letting

$$\frac{l}{l_{\max}} = l \left(\frac{\beta r}{2\alpha s} \right)^{1/2} = 1 + L, \quad (5.40)$$

(5.39) becomes

$$(1+L)^{-2} = \frac{\ln 2}{r} + 1 - 2 \ln(1+L)$$

and expanding in a Taylor series and including terms up to $O(L^2)$ we obtain

$$L_{a,b} \approx \pm \sqrt{\frac{\ln 2}{2r}}.$$

This leads to

$$B(s+T) = l_a - l_b = l_{\max}(L_a - L_b) \approx \left(\frac{2 \ln 2}{r} \right)^{1/2} \left(\frac{2\alpha s}{\beta r} \right)^{1/2}. \quad (5.41)$$

We conclude that the peak moves out at the rate

$$l_{\max}(t) = \left(\frac{2\alpha(t-T)}{\beta r} \right)^{1/2} \sim \left(\frac{t}{r} \right)^{1/2} \quad (5.42a)$$

and spreads out like

$$B(t) \approx \left(\frac{2 \ln 2}{r} \right)^{1/2} l_{\max}(t) \sim \frac{t^{1/2}}{r}. \quad (5.42b)$$

Now Theorem 5.1 gives asymptotic results for $t \geq T$ sufficiently large and the modal ratio estimate (5.4) contains the awkward term $\mu_{k,l}(t)$, which we can only control for l contained in some band $(K, K^2/C)$. Specific results such as (5.36a,b) and (5.42a,b) must therefore be interpreted with care. However, noting that $1/k^2$ decreases quickly, we might expect that we need only wait for the first few modes to decay before the asymptotic results become quite accurate. During this period the higher modes, which start very close to zero, will not have time to adjust much, for the unstable eigenvalues of the trivial solution in those directions are uniformly bounded (cf. 2.23). We can therefore hope that the modal energy evolution results of this section will provide a reasonable indication of how specific initial data develops; i.e. we can effectively take $T = 0$. In the next section we describe numerical results which show that this hope appears to be justified.

6. NUMERICAL RESULTS

We now describe some numerical experiments that seem to validate the estimates obtained for the nonlocal problem. These indicate good agreement with (5.36) and (5.42) which describe the manner in which the modal energy organizes and subsequently crawls out to the higher Fourier modes.

As our numerical model we investigate the $2N$ -dimensional truncated system

$$\begin{aligned} \dot{b}_k &= c_k \\ \dot{c}_k &= k^2 \left[\left(\left(1 - \frac{\alpha}{k^2} \right) - \sum b_j^2 \right) b_k - \beta c_k \right], \quad k = 1, \dots, N, \quad (N^2 > \alpha) \end{aligned} \quad (6.1)$$

obtained from the Galerkin projection (5.2) by ignoring the behavior of modes higher than N . This corresponds to restricting solutions of the nonlocal problem (2.5) to lie in the *invariant* $2N$ -dimensional subspace $X_N = \{ \{u, u_t\} \in H_0^2 \times L^2 \mid (u, \sin kx) = (u_t, \sin kx) = 0 \ \forall k > N \}$. As was shown in Section 4, the only stable solutions in this subspace are the two high mode equilibria $\{u, u_t\} = \{u_N^\pm, 0\}$. Solutions with initial data in X_N and with the N th mode $\{b_N, c_N\}$ initially present eventually end up with all the energy in this mode, in fact $u(x, t) \rightarrow \pm \frac{1}{N} \sqrt{\frac{2}{\pi} \left(1 - \frac{\alpha}{N^2} \right)} \sin Nx$ and $\|u_x\|^2 \rightarrow 1 - \alpha/N^2 > 1$ as $t \rightarrow \infty$, so that by choosing N large enough, we can come arbitrarily close to minimizing the energy E_2 . Nevertheless, the asymptotic shape of the solution changes remarkably when components of the initial data with wavenumbers greater than N are absent. To illustrate the effect of this truncation, let $u(t)$ be a solution of the nonlocal problem with $u(0)$ contained in the set A_2 of Theorem 4.6 and let $u_N(t) \in X_N$ be the solution corresponding to the initial data $u_N(0) \in X_N \subset A_1$ obtained by removal of all modes higher than the N th. We assume $u(0)$ (and

therefore also $u_N(0)$ to be close to the slow manifold. In the numerical experiments we chose $\|u_x(0)\| \simeq 1$ and $u_t(0) \simeq 0$ to ensure this.

The numerical simulations can be characterized as follows. After an initial time that is short compared to the rate of change in $\|u_x\|$, the k th mode of both solutions lies within a layer of thickness $\sim \frac{1}{k^2}$ of the slow manifold. The power spectrum $k \mapsto b_k^2$ is concentrated in the low wavenumber range, with almost no energy yet present in the higher modes. Evolution on the slow manifold now causes the modal energy to crawl out to the higher wave numbers, broadening its bandwidth as it goes. Both u and u_N can in this process sustain coherent spatial structures that are slowly refining with time. For u_N this continues for a time interval dependent on the initial degree of smoothness and the size $2N$ of the finite dimensional approximation. When the active band in the power spectrum of u_N reaches the high mode ceiling, the delicate modal balance responsible for the coherent spatial structures is destroyed, and as all the energy accumulates in the highest mode, more and more of the finite $(\sin Nx)$ oscillations characteristic of the stable equilibria u_N^\pm develop in the solution. In contrast, after this “cross-over” time, the corresponding infinite dimensional solution u continues to evolve as the modal bump crawls out to still higher wavenumbers, allowing arbitrarily fine structures to develop.

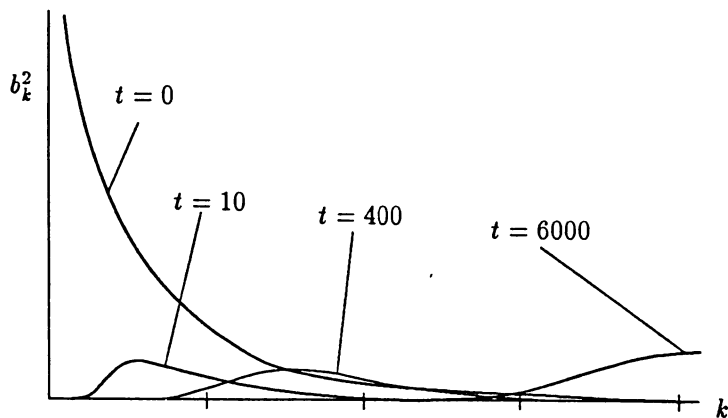

Figure 4 Development of the spectrum $b_k^2(t)$.

It is the close correspondence between u and u_N before the cross-over time that motivates studying (6.1) to gain insight into the asymptotic behavior of solutions starting in A_2 . The system (6.1) of $2N$ ODEs is quite stiff and was numerically integrated using the backwards differentiation algorithm DDEBDF from the SLATEC library using IBM Fortran double precision. When integrating more than 100 modes for times in

excess of 10,000 time units we found it profitable to use the vector facilities of the IBM3090 supercomputer of the Cornell National Supercomputer Facility. The spatial solution was reconstructed by performing a Fast Fourier Transform on the modal data. In Figure 4 we show the evolution of the modal energy of (6.1) using 40 modes with the parameter values $\alpha = \frac{1}{2}$, $\beta = 1$, $b_k(0) = Ce^{-k}$ and $c_k(0) = 0$. Note how after a short transition time the energy b_k^2 is concentrated in the lower modes, but that the lowest modes have decayed essentially to zero. Following this, energy slowly moves out to the higher wavenumbers, spreading as it does so, and finally all the energy accumulates in the 40th mode.

The next example displays in Figure 5 the formation of fine structure as well as sensitive dependence on initial conditions characteristic of the truly infinite dimensional problem. Using 100 modes, with $\alpha = \frac{1}{2}$ and $\beta = 1$, the initial data $b_k(0) = (A/k^2) \sin \frac{k\pi}{2}$ was chosen to display how C^1 initial data can sharpen up and display a localized structure (here at $x = \frac{\pi}{2}$) that refines until the active band in the power spectrum starts accumulating in the highest mode. Already at $t = 5000$ one can observe the fine oscillations (characteristic of the high mode equilibria) superimposed on the infinite dimensional solution. As in the previous example, the low modes quickly decay and the b_k 's evolve within an envelope which sweeps out to the higher wavenumbers. For non-smooth initial data the active band in modal space quickly reaches the highest modes, requiring high dimensional (and extremely stiff) systems to resolve the large-time behavior of the infinite dimensional problem. Figure 5a also clearly shows the sensitive dependence on initial conditions that is characteristic of the truly infinite dimensional nonlocal problem. Initially, the higher modes are almost unnoticeably small, yet after sufficient time has elapsed these modes become active and, since we started close to the slow manifold, even preserve their sign at $t = 0$ (cf. Section 4.3).

In Figure 6 we see the finite dimensional version of the "persistence of strain discontinuities" property of the nonlocal problem. Here $N = 200$, $\alpha = \frac{1}{2}$, $\beta = 1$ and we take $b_k(0) = A \frac{\sin k}{k}$, $c_k(0) = 0$, approximating a piecewise constant "strain" u_x at $t = 0$ with a jump in u_x at $x = 1$.

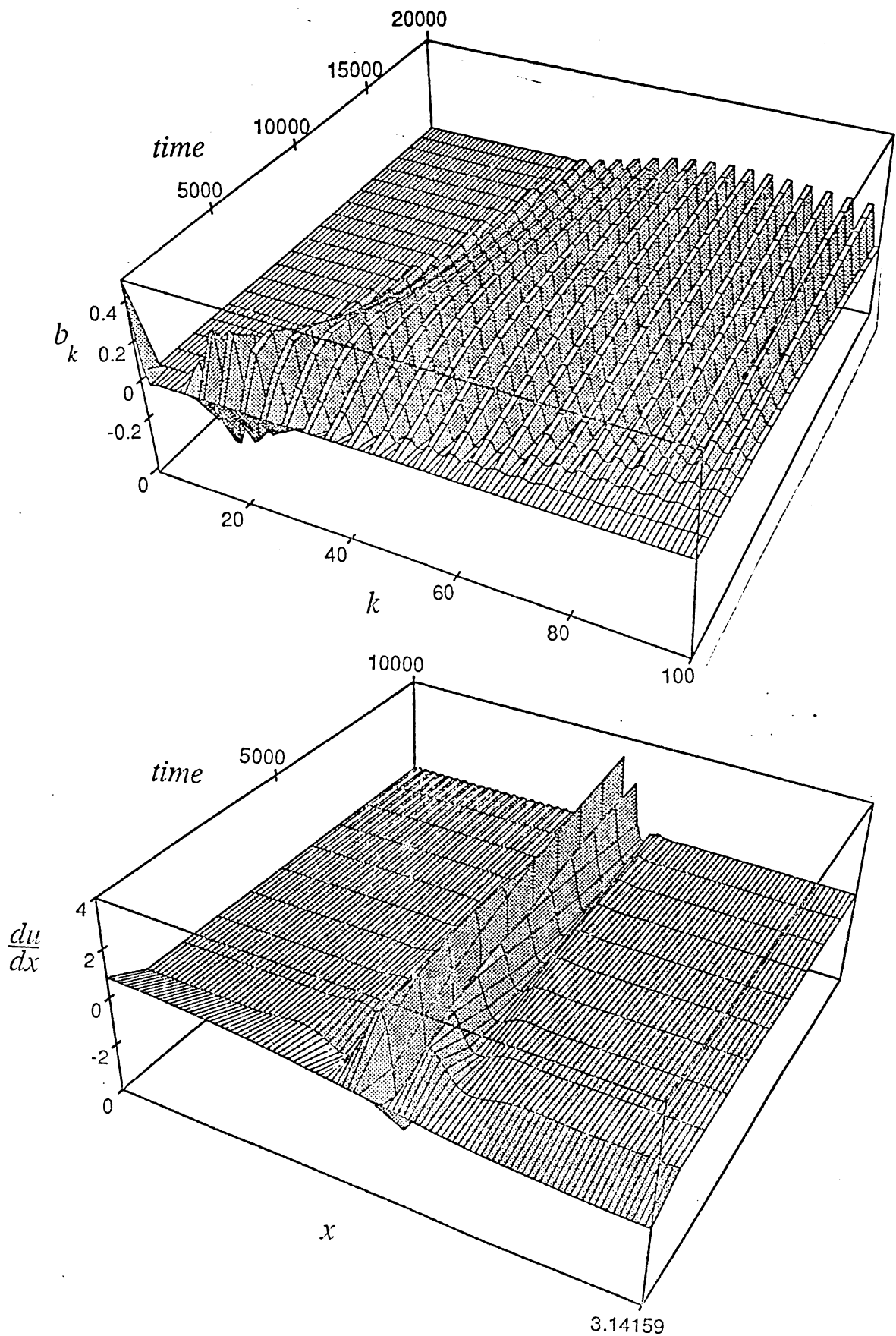

3.14159

Figure 5. Localization and creation of fine structure. (a) Fourier spectrum of $b_k(t)$; (b) u_x in physical space.

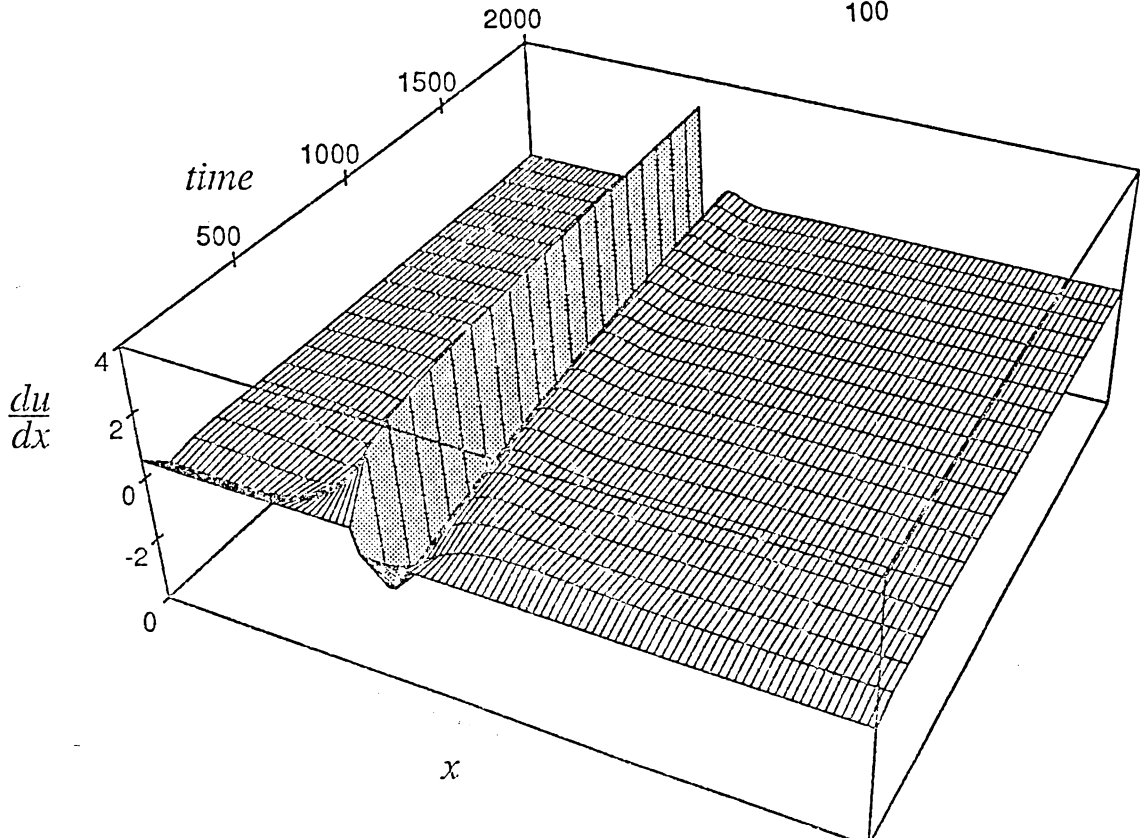
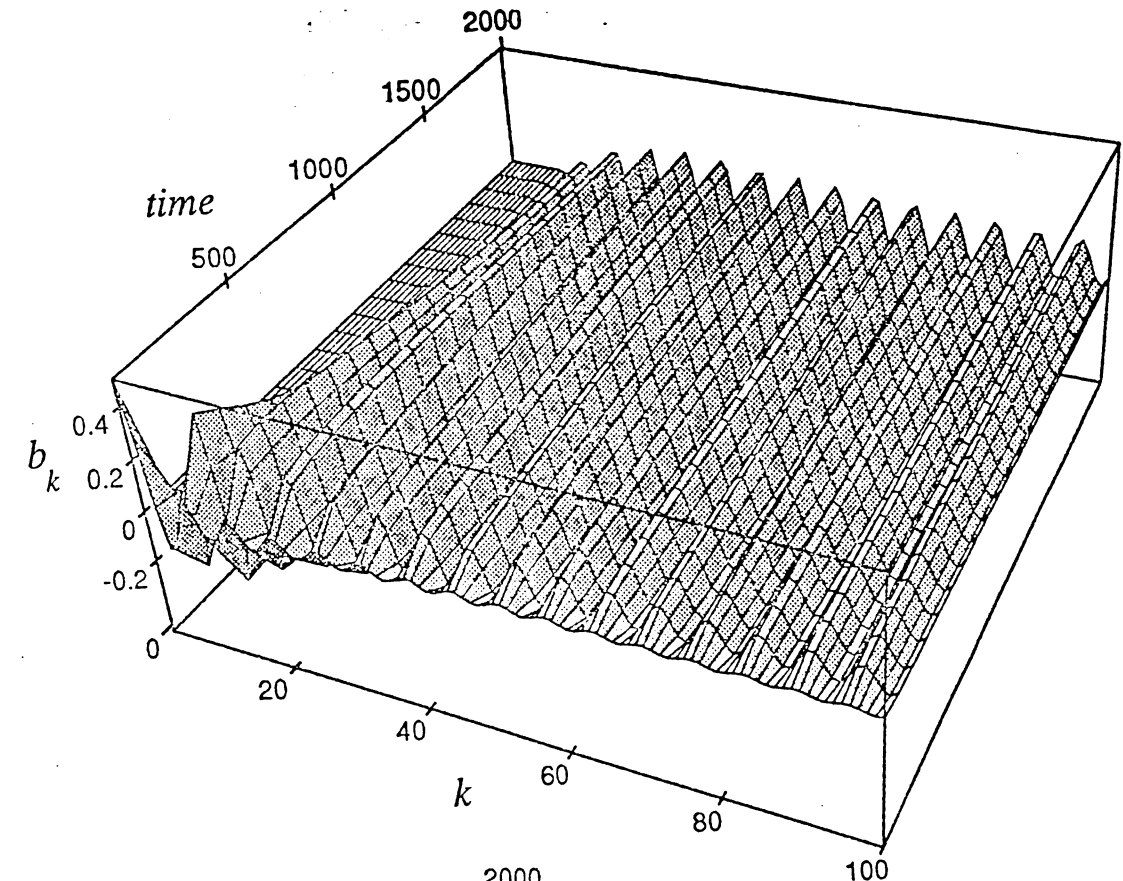

3.14159

Figure 6. Preservation of a strain discontinuity. (a) Fourier spectrum (first 100 modes), (b) u_x in physical space.

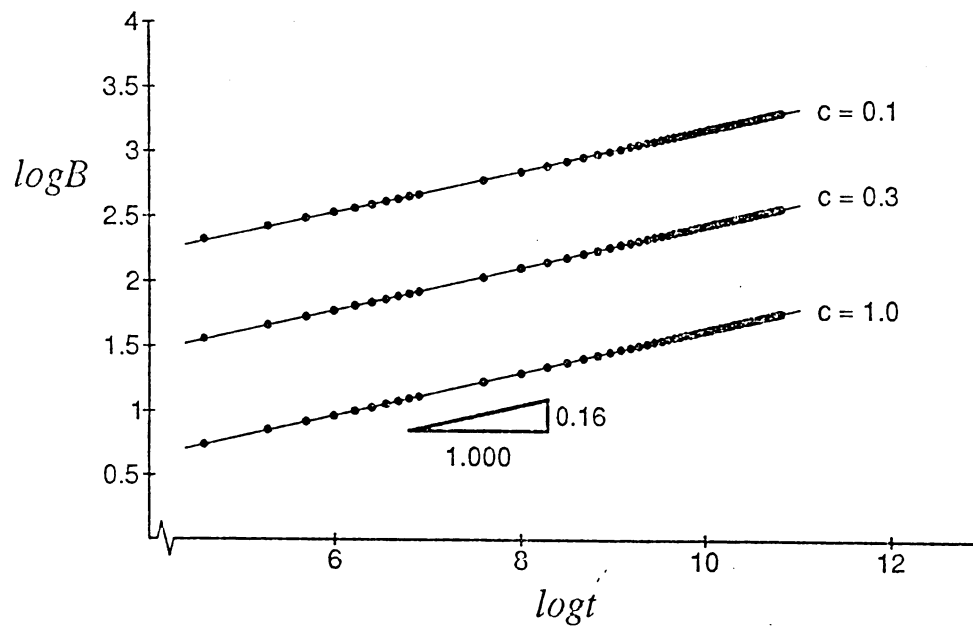
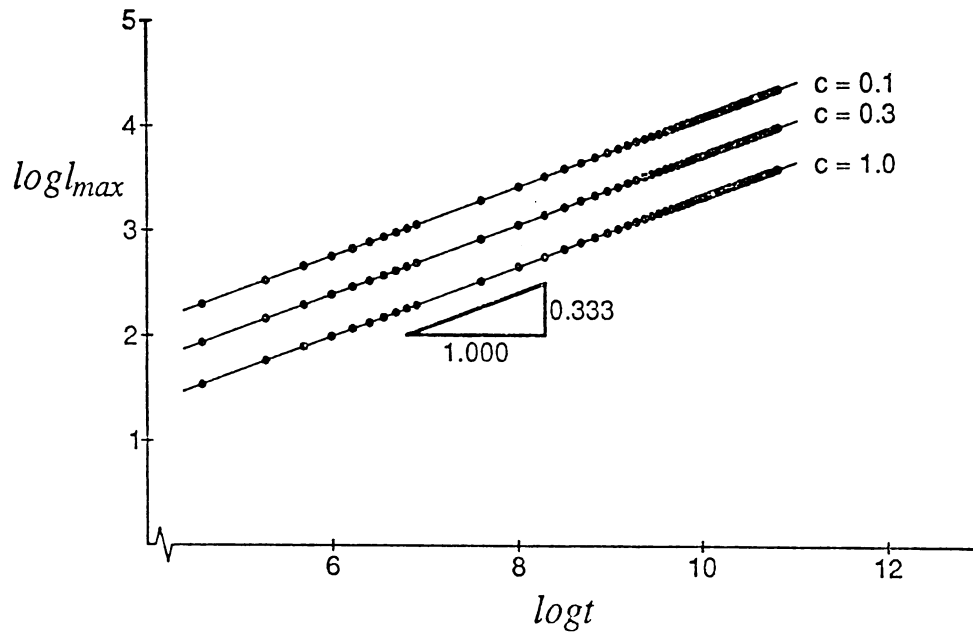

Figure 7. Asymptotic escape of energy for analytic initial data.

(a) l_{\max} vs. t ; (b) B vs. t .

In Section 5.2 we described by means of two examples how the smoothness of the initial data influences the manner in which the modal energy moves out to the higher wave numbers. We now test the estimates (5.36) and (5.42) concerning the peak l_{\max} and the half power bandwidth B of the power spectrum corre-

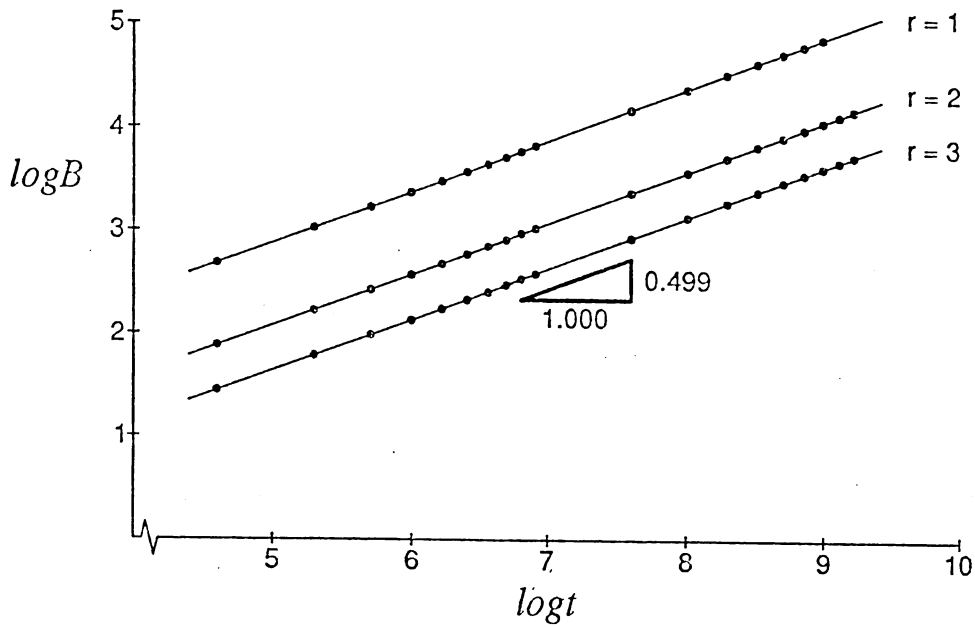
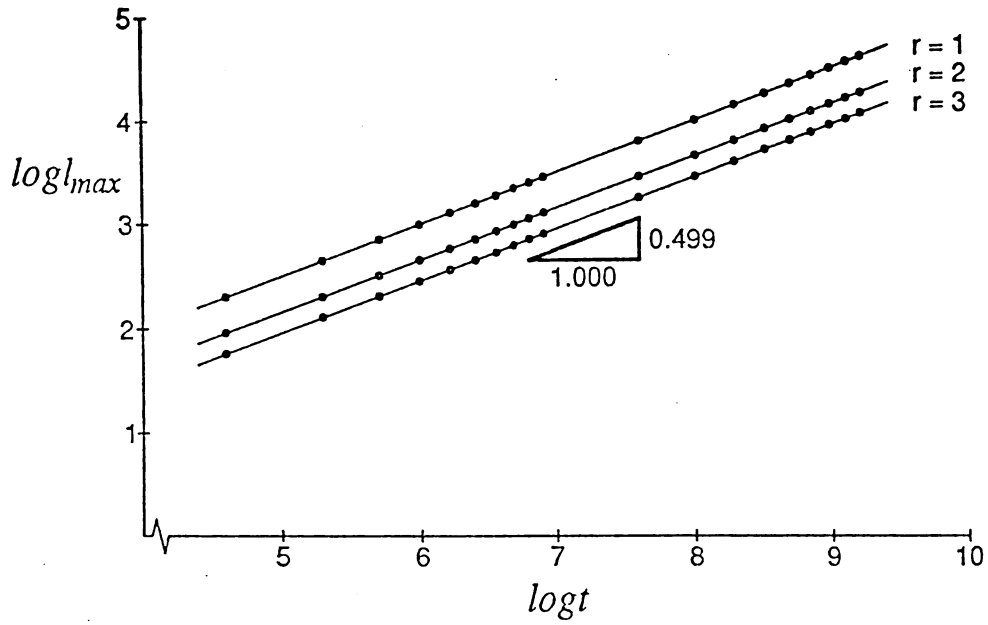

Figure 8. Asymptotic escape of energy for C^{r-1} initial data. (a)

l_{\max} vs. t , (b) B vs. t .

sponding to analytic and C^r initial data. The values l_{\max} and B are computed by assuming b_k^2 to depend smoothly on the parameter $k \in [0, N]$. For initial data of the form $c_k(0) = 0$ and $b_k(0) \sim e^{-ck}$ or k^{-r} , we found it useful to approximate the function $k \mapsto b_k^2(t)$ by $C_1 \exp[C_2 k + C_3/k^2] k^{C_4}$, where the C_i are determined by a least-squares fit over the “active” modes. This approximation, inspired by crude asymptotics

based on the balance

$$\alpha u \simeq \beta u_{xxt} \quad (6.2)$$

of linear terms in (2.4), proved to be quite accurate. For the choice $\alpha = \frac{1}{2}$, $\beta = 1$ and times as large as 50,000 s , C_3 remained within .01% of the theoretical value $\frac{-2\alpha t}{\beta}$, while C_2 and C_4 remained within .01% of their initial values, providing the finite dimensional version of the preservation of the initial degree of smoothness.

Initial Conditions	Asymptotic Estimates	Numerical Results
$c = 1$ $A = 2.5276$	$\ln l_{\max} = 0 + 0.33333 \ln t$ $\ln B = 0 + 0.16667 \ln t$	$\ln l_{\max} = 0.00122 + 0.33333 \ln t$ $\ln B = -0.02152 + 0.16517 \ln t$
$c = 0.3$ $A = 0.90671$	$\ln l_{\max} = 0.40132 + 0.33333 \ln t$ $\ln B = 0.80265 + 0.16667 \ln t$	$\ln l_{\max} = 0.40124 + 0.33337 \ln t$ $\ln B = 0.80158 + 0.16340 \ln t$
$c = 0.1$ $A = 0.47053$	$\ln l_{\max} = 0.76753 + 0.33333 \ln t$ $\ln B = 1.53531 + 0.16667 \ln t$	$\ln l_{\max} = 0.76729 + 0.33337 \ln t$ $\ln B = 1.57386 + 0.15997 \ln t$

Table 1

Using a 100 mode approximation, $\alpha = \frac{1}{2}$, $\beta = 1$ and modelling analytic initial data by $b_l(0) = Ae^{-cl}$, $c_l(0) = 0$ with $c = 1, 0.3$, and 0.1 , we found remarkable agreement with (5.36). Choosing A such that $\sum b_j^2(0) \simeq 1$ ensures that we start close to the slow manifold and hence can take $T \simeq 0$ in (5.36) to give $l_{\max}(t) \sim (\frac{t}{c})^{1/3}$ and $B(t) \sim t^{1/6}/c^2$. The numerical results are summarized in Table 1 and Figure 7. Note that natural logarithms have been used. Similarly, using a 200 mode approximation, $\alpha = \frac{1}{2}$, $\beta = 1$ and modelling C^{r-1} initial data by $b_l(0) = Al^{-r}$, $c_l(0) = 0$ with $r = 1, 2$, and 3 , we found remarkable agreement with (5.42) which predicts in this case that $l_{\max}(t) \sim (\frac{t}{r})^{1/2}$ and $B(t) \sim t^{1/2}/r$. When r is fixed, a sharper estimate for $B = l_b - l_a$ may be obtained by setting $\theta = \frac{2\alpha s}{\beta l^2}$ in (5.39) and numerically solving the resulting nonlinear relation

$$\theta e^{-\theta/r} = \left(\frac{1}{2}\right)^{1/r} \left(\frac{r}{l}\right) \quad (6.3)$$

to obtain l_a and l_b . We compare our numerical results against these slightly sharper estimates for $r =$

1, 2, and 3. A is once again chosen so as to start close to the slow manifold and be able to take $T \simeq 0$ in (5.39) and (5.42). The numerical results are summarized in Table 2 and Figure 8.

Initial Conditions	Asymptotic Estimates	Numerical Results
$r = 1$ $A = 0.78029$	$\ln l_{\max} = 0 + 0.50000 \ln t$ $\ln B = 0.38204 + 0.50000 \ln t$	$\ln l_{\max} = 0.00100 + 0.49988 \ln t$ $\ln B = 0.38318 + 0.49987 \ln t$
$r = 2$ $A = 0.96122$	$\ln l_{\max} = -0.34657 + 0.50000 \ln t$ $\ln B = -0.42218 + 0.50000 \ln t$	$\ln l_{\max} = -0.33983 + 0.49922 \ln t$ $\ln B = -0.41533 + 0.49921 \ln t$
$r = 3$ $A = 0.99144$	$\ln l_{\max} = -0.54931 + 0.50000 \ln t$ $\ln B = -0.86391 + 0.50000 \ln t$	$\ln l_{\max} = -0.53668 + 0.49855 \ln t$ $\ln B = -0.85108 + 0.49853 \ln t$

Table 2

7. CONCLUSIONS AND PHYSICAL IMPLICATIONS

As explained in the introduction, the models discussed in this paper were designed to provide insight into the dynamics of the formation of microstructure in crystals. Specifically, the local model (2.2) is related to a theory of martensitic transformations in single crystals described by Ball and James [1987, 1990]. This theory is based on a free energy $\psi(F, \theta)$ defined on the domain $\{(F, \theta) \in \mathbb{M}^{3 \times 3} \times \mathbb{R} : \det F > 0\}$. Here $\mathbb{M}^{3 \times 3}$ is the set of 3×3 matrices and θ is the temperature which, for the purpose of this discussion, we fix at a value below the transformation temperature. We write $\phi(F) = \psi(F, \theta)$. Deformations of the crystal are described by mappings $y : \Omega \rightarrow \mathbb{R}^3$, $\Omega \subset \mathbb{R}^3$, lying in the Sobolev space $W^{1,1}(\Omega; \mathbb{R}^3)$. The mappings y are required to be invertible, but we ignore this here; see Ball and James [1990] for details. The conditions of frame-indifference and symmetry imply that ϕ is not rank-one convex and in fact there are matrices $F^+, F^- \in \mathbb{M}^{3 \times 3}$ with the properties

$$\begin{aligned}
 F^+ - F^- &= a \otimes n; \\
 \phi(F^+) &= \phi(F^-) \leq \phi(F), \quad \forall F \in \text{dom } \phi.
 \end{aligned}
 \tag{7.1}$$

Let $F_\lambda \stackrel{\text{def}}{=} \lambda F^+ + (1 - \lambda)F^-$ for some $\lambda \in (0, 1)$. For a crystal subject to the linear displacement boundary conditions $y(z) = F_\lambda z$, $z \in \partial\Omega$, the total energy is

$$\int_{\Omega} \phi(Dy(z)) dz, \quad y \in \mathcal{A} = \{y \in W^{1,1}(\Omega; \mathbb{R}^3) \mid y = F_\lambda z, z \in \partial\Omega\}. \quad (7.2)$$

Alternatively, we can impose the boundary conditions in a weakened form and consider the energy

$$\int_{\Omega} [\phi(Dy(z)) + \mu|y(z) - F_\lambda z|^2] dz, \quad (7.3)$$

with $\mu > 0$. The energy (7.3) can also be thought of as that of a thin crystal plate glued to a rigid foundation with μ representing the bond stiffness.

It turns out (Ball and James [1990]) that with free energies appropriate to a cubic-to-tetragonal transformation, neither the minimum of (7.2) nor that of (7.3) is attained. If we put $y(z) = F^- z + \frac{1}{2}(u(z \cdot n) + z \cdot n)a$, let $\lambda = \frac{1}{2}$ and assume $\Omega = \{z \in \mathbb{R}^3 : 0 \leq z \cdot n \leq \pi, |z \times n|^2 \leq \pi^{-1}\}$ then, setting $x = z \cdot n$, the energy (7.3) becomes

$$\int_0^\pi [\mathcal{V}_1(u_x(x)) + \alpha u(x)^2] dx, \quad (7.4)$$

where $\alpha = \frac{1}{4}\mu|a|^2$ and \mathcal{V}_1 is a double-well energy with strict minima at $u_x = \pm 1$. Note that (7.4) is of precisely the same form as the potential part of our total energy E_1 . If $\{u^k\}$ is a minimizing sequence for the energy I of equation (1.1) then

$$y^k(z) = F^- z + \frac{1}{2}(u^k(z \cdot n) + z \cdot n)a \quad (7.5)$$

provides a minimizing sequence for (7.3). In fact in the cubic-to-tetragonal case such sequences are comprehensive in the sense that the deformation gradient of any other minimizing sequence for (7.2) or (7.3) has the same Young measure as that for Dy^k .

Model 2 seems not so closely related to an energy of physical interest, although free energies for ferromagnetic materials are both nonlocal and do exhibit nonattainment for some crystal symmetries (James and Kinderlehrer [1990]).

In both models 1 and 2 the parameter α represents a bond strength or boundary constraint: as α increases, the displacements $u(x)$ are penalized more severely. This feature appears explicitly in analysis of the equation linearized at the trivial solution:

$$u_{tt} = -u_{xx} - \alpha u + \beta u_{xxt}, \quad (7.6)$$

which, in common with the nonlocal model 2, has the eigenvalues:

$$\lambda = \frac{\beta l^2}{2} \left(-1 \pm \sqrt{1 + \frac{4(l^2 - \alpha)}{\beta^2 l^4}} \right), \quad l = 1, 2, \dots \quad (7.7)$$

(equation (2.23)). We note that, for $l < \sqrt{\alpha}$, these pairs of eigenvalues have negative real parts, so that, for $L < \sqrt{\alpha} < L+1$, the trivial solutions of both models 1 and 2 are locally exponentially stable to perturbations in the directions of the first L eigenfunctions $\{\sin lx\}_{l=1}^L$. In fact for model 2 it is clear that the nontrivial equilibria

$$u_k^\pm = \pm \frac{1}{k} \sqrt{\frac{2}{\pi} \left(1 - \frac{\alpha}{k^2} \right)} \sin kx, \quad (7.8)$$

of equation (2.20) only exist for $k > \sqrt{\alpha}$, and all perturbation components of the form $\{\sin lx, l < \sqrt{\alpha}\}$, decay exponentially. (Recall the structure of the invariant subspaces $X_N = \{\{u, v\} \mid \{u, v\} = \sum_{j=1}^N \{a_j, b_j\} \sin jx\}$.) Thus large α acts to establish a *minimum* degree of fineness ($O(\sqrt{\alpha})$) in model 2.

The same conclusion holds for model 1, as the following argument demonstrates. Observe that, under the transformation

$$(u, v, x) \mapsto \left(\frac{u}{\sqrt{\alpha}}, v, \frac{x}{\sqrt{\alpha}} \right), \quad (7.9)$$

the equilibrium equation (2.12) and integral (2.13) respectively become

$$\begin{aligned} u_x &= v \\ v_x &= \frac{u}{3v^2 - 1}, \end{aligned} \quad (7.10)$$

and

$$\frac{3v^2}{4} - \frac{v^2}{2} - \frac{u^2}{2} = \text{const.} \quad (7.11)$$

Thus, if $u^{(1)}$ is an admissible equilibrium for $\alpha = 1$ with the minimum possible number of jumps on $0 < x < \pi$ consistent with the requirement that $\frac{1}{\sqrt{3}} < |v| < \frac{2}{\sqrt{3}}$, then for any solution $u^{(\alpha)} = \sqrt{\alpha} u^{(1)}\left(\frac{x}{\sqrt{\alpha}}\right)$ with $\alpha \ll 1$ the number of jumps must be of $O(\sqrt{\alpha})$. On the phase plane of Figure 1, the effect of (7.9) is to shrink the u coordinate and restrict the sectors between the unbounded components of the separatrices in which admissible trajectories lie.

In simple semilinear systems possessing Liapunov (energy) functions such as the Chafee–Infante [1974] problem:

$$u_t = u_{xx} + f(u) \quad (\text{e.g. } f(u) = u - u^3), \quad (7.12)$$

or the damped nonlinear wave equation:

$$u_{tt} = u_{xx} - \beta u_t + f(u), \quad (7.13)$$

one expects typical solutions to approach a stationary solution corresponding to a local minimum of energy. The traditional proof of this begins by establishing precompactness of positive orbits, cf. Ball [1990]. In the present case precompactness fails in general for models 2 and 3, while for model 1 it is an open question. However, all three models are strongly dissipative with energy decreasing monotonically on solutions, excluding any chaotic or even time periodic motions.

As we have seen, the fate of solutions differs radically from model to model, and in all cases is dramatically influenced by the initial data. In model 1, no solution minimizes energy and so, while α determines a minimum degree of fineness and there is no limit to the maximum possible fineness, in practice typical solutions appear to approach equilibria with only finitely many jumps in strain u_x and these asymptotic states seem to be closely related to the initial data. In fact the results of Theorem 4.10 prevent the motion of strain discontinuities and formation of new ones in finite time. A physical interpretation of the nonminimization result is that the kinetic energy

$$\frac{1}{2} \|u_t\|^2 = \frac{1}{2} \|p_x\|^2 \quad (7.14)$$

is used up so quickly, due to the smoothing action of the parabolic part of (3.6₁), that after a short time has elapsed, insufficient additional energy is present to form new jumps. To form such jumps, and hence further reduce $E_1[u, u_t]$, would require a temporary increase in the local potential energy density $\frac{1}{4}(u_x^2 - 1)^2 + \alpha \frac{u^2}{2}$ as $u_x(x)$ passes through zero on some set of positive measure. The rapid decrease in total kinetic energy acts to prevent this. If a similar phenomenon occurred for realistic dynamical models of crystals, this could provide a mechanism for limiting fineness additional to effects such as surface energy. For a discussion of this, see Ball and James [1990]. In model 2, in contrast, almost all solutions *do* minimize energy. Here the nonlocal nonlinear term allows new zeroes to appear in u_x without appreciable kinetic energy expenditure. However, our asymptotic results show that the rate at which and manner in which the “modal strain energy” of $\|u_x\|^2$ escapes to arbitrarily high Fourier wavenumbers is controlled by the *smoothness* of the initial data.

This rather delicate influence of initial data — a sensitive dependence very different from that familiar in chaotic dynamical systems — is of possible relevance in relation to “dynamic relaxation” methods for

determining equilibrium states of nonlinear elastic continua with non-convex strain energies. For example, in Silling [1988a,b;1989], the equilibrium equations for anti-plane shear cracks and screw dislocations in two dimensional continua were supplemented by the addition of inertia and dissipation terms $(\beta \frac{\partial u}{\partial t}; \rho(\mathbf{x}) \frac{\partial^2 u}{\partial t^2})$ and initial value problems solved numerically and allowed to run until $|\frac{\partial u}{\partial t}|$ was less than some prescribed value at every mesh point. A variety of two phase equilibria were obtained and analyzed statistically in the light of energy stability considerations such as those of Section 2.2.

If, as in the present models, initial data can so acutely affect either the fineness of the resulting equilibria or the rate at which fine structure develops, then such a dynamical process run for finite times from specific (sets of) initial data might yield results of doubtful statistical significance. Of course, if the underlying physical mechanism displays sensitive dependence (on initial defects and grain boundaries, for example), then this type of behavior may reflect the true situation. In this respect we particularly wish to point out that in our models the velocities u_t , both in L^∞ and in L^2 , decay quickly to extremely low levels. While in model 1 this does appear to signal the “lock-in” of strain discontinuities (and thus cessation of computation might give reasonable approximations of equilibria), in model 2 refinement continues on the extremely slow time scales such as $k \sim t^{1/3}$ or $t^{1/2}$ in Fourier wavenumber space.

Acknowledgements

The research described in this paper was variously supported by SERC GR/E/69690 and GR/D/73096 (JMB, RDJ, RLP) NSF DMS 87-03656 and ARO DAAG 29-85-C-0018, Mathematical Sciences Institute (PJH, PJS), AFOSR and NSF DMS 87-18881 (RDJ) and NSF DMS 89-02422 (RLP). The computations of section 6 were done using the Cornell National Supercomputer Facility, a resource of the Center for Theory and Simulations in Science and Engineering (Cornell Theory Center), which receives major funding from the National Science Foundation and IBM Corporation, with additional support from New York State and members of the Corporate Research Institute.

References

- R. A. Adams [1975] *Sobolev Spaces*, Academic Press, New York.
- J. M. Ball [1978] On the asymptotic behaviour of generalized processes, with applications to nonlinear evolution equations. *J. Diff. Eqns.* 27, 224-265.

- J. M. Ball [1990] Dynamics and minimizing sequences. In *Problems Involving Change of Type*, (K. Kirchgässner, Editor.) Springer Lecture Notes in Physics 359, Springer Verlag, New York, Heidelberg, Berlin, 3–16.
- J. M. Ball and J. Carr [1988] Asymptotic behaviour of solutions of the Becker–Döring equations for arbitrary initial data. *Proc. Roy. Soc. Edinburgh A*, 108, 109–116.
- J. M. Ball, J. Carr and O. Penrose [1986] The Becker–Döring cluster equations: basic properties and asymptotic behaviour of solutions. *Comm. Math. Phys.* 104, 657–692.
- J. M. Ball and R. D. James [1987] Fine phase mixtures as minimizers of energy. *Archive for Rational Mech. and Anal.* 100, 13–52.
- J. M. Ball and R. D. James [1990], Proposed experimental tests of a theory of fine microstructure and the two-well problem (preprint).
- J. Carr [1981] *Applications of Centre Manifold Theory*, Springer Verlag, New York, Heidelberg, Berlin.
- L. Cesari [1983] *Optimization–Theory and Applications*, Springer–Verlag. New York, Heidelberg, Berlin.
- N. Chafee and E. Infante [1974] A bifurcation problem for a nonlinear parabolic equation. *J. Appl. Anal.* 4., 17–39.
- P. Constantin, C. Foias, R. Temam and B. Nicolaenko [1989] *Integral Manifolds and Inertial Manifolds for Dissipative Partial Differential Equations*, Springer Verlag, New York, Heidelberg, Berlin.
- C. R. Doering, J. D. Gibbon, D. Holm, and B. Nicolaenko [1988] Low dimensional behaviour in the complex Ginzburg–Landau equation. *Nonlinearity* 1, 279–309.
- N. Fenichel [1979] Geometric singular perturbation theory for ordinary differential equations. *J. Diff. Eqns* 31, 53–98.
- D. Henry [1981] *Geometric Theory of Semilinear Parabolic Equations*, Springer Lecture Notes in Mathematics No. 840, Springer Verlag, New York, Heidelberg, Berlin.
- D. Hoff and J. Smoller [1985] Solutions in the large for certain nonlinear parabolic systems, *Anal. Non lin.* 2, 2345–2351.
- R. D. James and D. Kinderlehrer [1990], Frustration in ferromagnetic materials. *Continuum Mechanics and Thermodynamics* (to appear).
- A. Kelley [1967] The stable, center–stable, center, center–unstable and unstable manifolds. *J. Differential Equations* 3, 546–570.
- M. Miklavčič [1985] Stability for semilinear parabolic equations with noninvertible linear operator. *Pacific J. of Math* 118, 199–214.
- A. Novick–Cohen and R. L. Pego [1990] Stable patterns in a viscous diffusion equation. *Transactions Amer. Math. Soc.* (to appear).
- R. L. Pego [1987] Phase transitions in one–dimensional nonlinear viscoelasticity: admissibility and stability. *Arch. Rat. Mech. and Anal.* 97, 353–394.
- V. A. Pliss [1964] A reduction principle in the theory of the stability of motion. *Izv. Akad. Nauk. SSSR. Math. Ser.* 28, 1297–1324.
- S. A. Silling [1988a] Numerical studies of loss of ellipticity near singularities in an elastic material. *J. Elast.* 19, 213–239.
- S. A. Silling [1988b] Consequences of the Maxwell relation for anti–plane shear deformations of an elastic solid. *J. Elast.* 19, 241–284.

- S. A. Silling [1989] Phase changes induced by deformation in isothermal elastic crystals. Preprint, Brown University.
- M. Slemrod [1989] Trend to equilibrium in the Becker–Döring cluster equations. *Nonlinearity* 2, 429–443.
- R. Temam [1988] *Infinite-Dimensional Dynamical Systems in Mechanics and Physics*, Springer Verlag, New York, Heidelberg, Berlin
- K. Yoshida [1980] *Functional Analysis*, (6th edition), Springer Verlag, New York, Heidelberg, Berlin.
- L. C. Young [1980] *Lectures on the Calculus of Variations and Optimal Control Theory*, Chelsea, New York.

Recent IMA Preprints

#	Author/s	Title
637	Xinfu Chen ,	Generation and propagation of the interface for reaction–diffusion equations
638	Philip Korman ,	Dynamics of the Lotka–Volterra systems with diffusion
639	Harlan W. Stech ,	Generic Hopf bifurcation in a class of integro-differential equations
640	Stephane Laederich ,	Periodic solutions of non linear differential difference equations
641	Peter J. Olver ,	Canonical Forms and Integrability of BiHamiltonian Systems
642	S.A. van Gils, M.P. Krupa and W.F. Langford ,	Hopf bifurcation with nonsemisimple 1:1 Resonance
643	R.D. James and D. Kinderlehrer ,	Frustration in ferromagnetic materials
644	Carlos Rocha ,	Properties of the attractor of a scalar parabolic P.D.E.
645	Debra Lewis ,	Lagrangian block diagonalization
646	Richard C. Churchill and David L. Rod ,	On the determination of Ziglin monodromy groups
647	Xinfu Chen and Avner Friedman ,	A nonlocal diffusion equation arising in terminally attached polymer chains
648	Peter Gritzmann and Victor Klee ,	Inner and outer j - Radii of convex bodies in finite- dimensional normed spaces
649	P. Szmolyan ,	Analysis of a singularly perturbed traveling wave problem
650	Stanley Reiter and Carl P. Simon ,	Decentralized dynamic processes for finding equilibrium
651	Fernando Reitich ,	Singular solutions of a transmission problem in plane linear elasticity for wedge-shaped regions
652	Russell A. Johnson ,	Cantor spectrum for the quasi-periodic Schrödinger equation
653	Wenxiong Liu ,	Singular solutions for a convection diffusion equation with absorption
654	Deborah Brandon and William J. Hrusa ,	Global existence of smooth shearing motions of a nonlinear viscoelastic fluid
655	James F. Reineck ,	The connection matrix in Morse–Smale flows II
656	Claude Baesens, John Guckenheimer, Seunghwan Kim and Robert Mackay ,	Simple resonance regions of torus diffeomorphisms
657	Willard Miller, Jr. ,	Lecture notes in radar/sonar: Topics in Harmonic analysis with applica- tions to radar and sonar
658	Calvin H. Wilcox ,	Lecture notes in radar/sonar: Sonar and Radar Echo Structure
659	Richard E. Blahut ,	Lecture notes in radar/sonar: Theory of remote surveillance algorithms
660	D.V. Anosov ,	Hilbert’s 21st problem (according to Bolibruch)
661	Stephane Laederich ,	Ray–Singer torsion for complex manifolds and the adiabatic limit
662	Geneviève Raugel and George R. Sell ,	Navier-Stokes equations in thin 3d domains: Global regularity of solutions I
663	Emanuel Parzen ,	Time series, statistics, and information
664	Andrew Majda and Kevin Lamb ,	Simplified equations for low Mach number combustion with strong heat release
665	Ju. S. Il’yashenko ,	Global analysis of the phase portrait for the Kuramoto–Sivashinsky equation
666	James F. Reineck ,	Continuation to gradient flows
667	Mohamed Sami Elbially ,	Simultaneous binary collisions in the collinear N -body problem
668	John A. Jacquez and Carl P. Simon ,	Aids: The epidemiological significance of two different mean rates of partner-change
669	Carl P. Simon and John A. Jacquez ,	Reproduction numbers and the stability of equilibria of SI models for heterogeneous populations
670	Matthew Stafford ,	Markov partitions for expanding maps of the circle
671	Ciprian Foias and Edriss S. Titi ,	Determining nodes, finite difference schemes and inertial manifolds
672	M.W. Smiley ,	Global attractors and approximate inertial manifolds for abstract dissipative equations
673	M.W. Smiley ,	On the existence of smooth breathers for nonlinear wave equations
674	Hitay Özbay and Janos Turi ,	Robust stabilization of systems governed by singular integro-differential equations
675	Mary Silber and Edgar Knobloch ,	Hopf bifurcation on a square lattice
676	Christophe Golé ,	Ghost circles for twist maps
677	Christophe Golé ,	Ghost tori for monotone maps
678	Christophe Golé ,	Monotone maps of $T^n \times R^n$ and their periodic orbits
679	E.G. Kalnins and W. Miller, Jr. ,	Hypergeometric expansions of Heun polynomials
680	Victor A. Pliss and George R. Sell ,	Perturbations of attractors of differential equations
681	Avner Friedman and Peter Knabner ,	A transport model with micro- and macro-structure
682	E.G. Kalnins and W. Miller, Jr. ,	A note on group contractions and radar ambiguity functions
683	George R. Sell ,	References on dynamical systems
684	Shui-Nee Chow, Kening Lu and George R. Sell ,	Smoothness of inertial manifolds
685	Shui-Nee Chow, Xiao-Biao Lin and Kening Lu ,	Smooth invariant foliations in infinite dimensional spaces

- 686 **Kening Lu**, A Hartman–Grobman theorem for scalar reaction-diffusion equations
- 687 **Christophe Golé and Glen R. Hall**, Poincaré’s proof of Poincaré’s last geometric theorem
- 688 **Mario Taboada**, Approximate inertial manifolds for parabolic evolutionary equations via Yosida approximations
- 689 **Peter Rejto and Mario Taboada**, Weighted resolvent estimates for Volterra operators on unbounded intervals
- 690 **Joel D. Avrin**, Some examples of temperature bounds and concentration decay for a model of solid fuel combustion
- 691 **Susan Friedlander and Misha M. Vishik**, Lax pair formulation for the Euler equation
- 692 **H. Scott Dumas**, Ergodization rates for linear flow on the torus
- 693 **A. Eden, A.J. Milani and B. Nicolaenko**, Finite dimensional exponential attractors for semilinear wave equations with damping
- 694 **A. Eden, C. Foias, B. Nicolaenko & R. Temam**, Inertial sets for dissipative evolution equations
- 695 **A. Eden, C. Foias, B. Nicolaenko & R. Temam**, Hölder continuity for the inverse of Mañé’s projection
- 696 **Michel Chipot and Charles Collins**, Numerical approximations in variational problems with potential wells
- 697 **Huanan Yang**, Nonlinear wave analysis and convergence of MUSCL schemes
- 698 **László Gerencsér and Zsuzsanna Vágó**, A strong approximation theorem for estimator processes in continuous time
- 699 **László Gerencsér**, Multiple integrals with respect to L -mixing processes
- 700 **David Kinderlehrer and Pablo Pedregal**, Weak convergence of integrands and the Young measure representation
- 701 **Bo Deng**, Symbolic dynamics for chaotic systems
- 702 **P. Galdi, D.D. Joseph, L. Preziosi, S. Rionero**, Mathematical problems for miscible, incompressible fluids with Korteweg stresses
- 703 **Charles Collins and Mitchell Luskin**, Optimal order error estimates for the finite element approximation of the solution of a nonconvex variational problem
- 704 **Peter Gritzmann and Victor Klee**, Computational complexity of inner and outer j -radii of polytopes in finite-dimensional normed spaces
- 705 **A. Ronald Gallant and George Tauchen**, A nonparametric approach to nonlinear time series analysis: estimation and simulation
- 706 **H.S. Dumas, J.A. Ellison and A.W. Sáenz**, Axial channeling in perfect crystals, the continuum model and the method of averaging
- 707 **M.A. Kaashoek and S.M. Verduyn Lunel**, Characteristic matrices and spectral properties of evolutionary systems
- 708 **Xinfu Chen**, Generation and Propagation of interfaces in reaction diffusion systems
- 709 **Avner Friedman and Bei Hu**, Homogenization approach to light scattering from polymer-dispersed liquid crystal films
- 710 **Yoshihisa Morita and Shuichi Jimbo**, ODEs on inertial manifolds for reaction-diffusion systems in a singularly perturbed domain with several thin channels
- 711 **Wenxiong Liu**, Blow-up behavior for semilinear heat equations: multi-dimensional case
- 712 **Hi Jun Choe**, Hölder continuity for solutions of certain degenerate parabolic systems
- 713 **Hi Jun Choe**, Regularity for certain degenerate elliptic double obstacle problems
- 714 **Fernando Reitich**, On the slow motion of the interface of layered solutions to the scalar Ginzburg–Landau equation
- 715 **Xinfu Chen and Fernando Reitich**, Local existence and uniqueness of solutions of the Stefan problem with surface tension and kinetic undercooling
- 716 **C.C. Lim, J.M. Pimbley, C. Schmeiser and D.W. Schwendeman**, Rotating waves for semiconductor inverter
- 717 **W. Balsler, B.L.J. Braaksma, J.-P. Ramis and Y. Sibuya**, Multisummability of formal power series solutions of linear ordinary differential equations
- 718 **Peter J. Olver and Chehrzad Shakiban**, Dissipative decomposition of partial differential equations
- 719 **Clark Robinson**, Homoclinic bifurcation to a transitive attractor of Lorenz type, II
- 720 **Michelle Schatzman**, A simple proof of convergence of the QR algorithm for normal matrices without shifts
- 721 **Ian M. Anderson, Niky Kamran and Peter J. Olver**, Internal, external and generalized symmetries
- 722 **C. Foias and J.C. Saut**, Asymptotic integration of Navier–Stokes equations with potential forces. I
- 723 **Ling Ma**, The convergence of semidiscrete methods for a system of reaction-diffusion equations
- 724 **Adelina Georgescu**, Models of asymptotic approximation
- 725 **A. Makagon and H. Salehi**, On bounded and harmonizable solutions on infinite order arma systems
- 726 **San-Yih Lin and Yan-Shin Chin**, An upwind finite-volume scheme with a triangular mesh for conservation laws
- 727 **J.M. Ball, P.J. Holmes, R.D. James, R.L. Pego & P.J. Swart**, On the dynamics of fine structure
- 728 **KangPing Chen and Daniel D. Joseph**, Lubrication theory and long waves