

**A β AFFECTS APOE TRANSCRIPTIONALLY THROUGH THE
ACTIVATION OF β -AR, cAMP AND AP-2**

A DISSERTATION
SUBMITTED TO THE FACULTY OF THE GRADUATE SCHOOL
OF THE UNIVERSITY OF MINNESOTA
BY

Ximena Serenella Rossello

IN PARTIAL FULFILLMENT OF THE REQUIREMENTS
FOR THE DEGREE OF

DOCTOR OF PHILOSOPHY

W. Gibson Wood, Advisor

SEPTEMBER 2009

ACKNOWLEDGEMENTS

I would like to thank Dr. Colin Campbell, Dr. Timothy Walseth and Dr. Esam El-Fakahany, my thesis committee, for all their support and guidance throughout the years.

I especially want to thank Dr. Colin Campbell for his encouragement, kindness, and invaluable advice since the very beginning.

I would like to express my gratitude to Dr. Gibson Wood. I greatly appreciate his confidence in my abilities and guidance these past 5 years. I feel honored to have been part of his lab.

Special thanks to the members of the Wood lab, past and present, for their knowledge, help, advice and camaraderie. I particularly want to thank Dr. Urule Igbavboa for his patience and for sharing his skills and techniques.

I would also like to acknowledge the staff at the VA Hospital, MN for their support and friendship.

My appreciation also goes to the Pharmacology department, faculty, staff and classmates. In particular to the Lange and Wei labs for their assistance and advice throughout the last year. Without their help I could not have been able to complete my thesis.

Last but not least I want to thank my family, even though they are far away, their words of encouragement always felt close, I couldn't have done it without their constant support.

ABSTRACT

Two key players in the development of Alzheimer's disease (AD) are amyloid beta protein (A β) and apolipoprotein E (apoE). We and others have reported that A β elevates apoE protein levels in astrocytes, which in turn could alter lipid trafficking and cell function. The mechanism for the A β -induced increase in apoE levels is not clearly understood. We propose that A β affects apoE transcriptionally through the activation of the beta-adrenergic receptor (β AR), cAMP and the activator protein 2 (AP-2).

To test this hypothesis it was first determined if the stimulation of apoE protein levels by A β was triggered by an upregulation of apoE mRNA, in contrast to changes in secretion or degradation. The results show a time-dependent increase in apoE mRNA expression levels with peak expression reached after 1 hour of A β treatment. β AR antagonists were used to evaluate the involvement of the β AR. The antagonists significantly inhibited the A β -induced stimulation of apoE mRNA and protein levels.

In order to further understand the mechanism behind these results we assessed cAMP role in the proposed A β -apoE pathway. This second messenger has been associated with AD and has been shown to elevate apoE message and secretion levels. The data shows an A β -dependent elevation in cAMP levels as well as an increase in apoE levels after dBcAMP treatment, confirming the activation of a cAMP-dependent pathway. In addition, I provide evidence that confirms the participation of the transcription factor AP-2, specifically that of AP-2 β . AP-2 is known to be unregulated by cAMP and to bind to the apoE promoter. I report an increase in AP-2 β translocation to the nucleus after both cAMP and A β treatment and confirm its participation in the activation of the apoE promoter.

In conclusion, my work reveals a novel pathway for A β stimulation of apoE abundance in astrocytes involving β AR and the transcription factor AP-2 β . These findings not only help clarify the relationship between A β and apoE but also help understand AD progression and possibly show a mechanism that could aid in the fight against this fast growing disease.

TABLE OF CONTENTS

Acknowledgements	i
Abstract	ii
Table of Contents	iv
List of Tables	vi
List of Figures	vii
CHAPTER 1: Alzheimer's Disease	1 - 12
Prevalence and Mortality	1
Alzheimer's Disease	4
Hereditary versus late-onset AD	6
Treatment and Prevention	8
CHAPTER 2: AmyloidBeta	13 - 18
The Amyloid Cascade Hypothesis	13
APP Processing	14
Forms of A β	17
A β Structure and Toxicity	18
CHAPTER 3: Astrocytes and AD	19 - 24
Astrocyte Function	19
ApoE Synthesis and Function	20
ApoE and AD	23
CHAPTER 4: Aβ₁₋₄₂ increases apoE levels in mouse primary astrocytes	25 - 36
Introduction	25
Material and Methods	27
Results	31
Discussion	33
CHAPTER 5: Aβ₁₋₄₂ regulates apoE through cAMP	37 - 45
Introduction	37
Material and Methods	39
Results	42
Discussion	44
CHAPTER 6: Fresh Aβ₁₋₄₂ acts on β-adrenergic receptors	46 - 62
Introduction	46
Material and Methods	50
Results	53
Discussion	59
	iv

CHAPER 7: Aβ₁₋₄₂ stimulates apoE expression levels by actions of the transcription factor AP-2	63 - 84
Introduction	63
Material and Methods	69
Results	74
Discussion	81
General Conclusions	85 - 91
References	92 - 112

LIST OF TABLES

Chapter 1	
Table 1. AD treatment chart	10
Chapter 3	
Table 1. Prevalence of the human apoE isoforms and their key differences	23
Chapter 5	
Table 1. Vessel cAMP immunostaining in AD and control brains	38
Chapter 7	
Table 1. Chromosomal locations of AP-2 genes	65

LIST OF FIGURES

Chapter 1

Figure 1. Percentage change in Leading Cause of Death from 2000 to 2005	2
Figure 2. Age-adjusted death rates for selected leading causes of death: United States, 1958-2005	3
Figure 3. Death rates for AD among persons ages 65 and older by sex and age (2002)	3
Figure 4. Alois Alzheimer (1864–1915) and the Pathological hallmarks of Alzheimer’s disease	5
Figure 5. Projections of AD disease, prevalence by regions	11

Chapter 2

Figure 1. Amyloid cascade hypothesis	13
Figure 2. Schematic diagram of APP processing and production of A β	14
Figure 3. Proteolytic processing of APP	15
Figure 4. Morphology of A β assemblies	16
Figure 5. Effect on neuronal viability of different forms of A β_{1-42} and A β_{1-40}	17

Chapter 3

Figure 1. Distribution of apoE mRNA in different tissues	21
Figure 2. Comparison of apoE gene frequencies	22

Chapter 4

Figure 1. Fresh A β_{1-42} but not aged A β_{1-42} increases apoE levels in DITNC1 rat astrocytes	25
Figure 2. Aggregation of A β_{1-42} and A β_{1-40}	26
Figure 3. A β_{1-42} increases apoE protein levels in primary astrocytes	31
Figure 4. A β_{1-42} increases apoE mRNA expression levels in primary astrocytes	32

Chapter 5

Figure 1. Effects of dBcAMP on apoE expression and secretion in primary	37
---	----

rat astrocytes	
Figure 2. $A\beta_{1-42}$ increases cAMP levels in primary astrocytes	42
Figure 3. ApoE abundance is increased by dibutyryl-cAMP in DITNC1 astrocytes	43
Chapter 6	
Figure 1. Isoproterenol stimulates intracellular cAMP accumulation	47
Figure 2. Isoproterenol elevates apoE secretion levels	48
Figure 3. Neuroprotection by clenbuterol is mediated by specific β_2 AR stimulation	48
Figure 4. β AR agonist, isoproterenol, increases apoE expression levels	54
Figure 5. β AR antagonists inhibit $A\beta_{1-42}$ stimulatory effects on apoE mRNA levels	55
Figure 6. Selective β_1 and β_2 AR antagonists inhibit $A\beta_{1-42}$ induced stimulation of apoE protein levels	56
Figure 7. Selective β_1 and β_2 AR antagonists inhibit $A\beta_{1-42}$ induced stimulation of cAMP levels	57
Figure 8. Serotonin and arterenol effects on apoE protein levels	58
Chapter 7	
Figure 1. cAMP, AP-2 and apoE	64
Figure 2. Alignment of AP-2 proteins	66
Figure 3. Nucleotide sequence of upstream region of the human apoE gene	72
Figure 4. Expression of AP-2 isoforms in primary astrocytes	74
Figure 5. Protein expression of AP-2 γ	75
Figure 6. dBcAMP effects on nuclear AP-2 levels	76
Figure 7. $A\beta_{1-42}$ effects on total AP-2 levels in primary astrocytes	77
Figure 8. $A\beta_{1-42}$ effects on nuclear AP-2 levels in primary astrocytes	78
Figure 9. AP-2 DNA-binding after $A\beta$ treatment	79
Figure 10. ApoE promoter activity	80

CHAPTER 1

ALZHEIMER'S DISEASE

Prevalence and Mortality

In the early 20th century Americans died young, affected by a variety of infectious diseases, with most dying before the age of 65. Since 1900, life expectancy in the United States has increased dramatically (Gorina et al., 2006; Xu et al., 2009). Over the years, death rates have dropped and chronic diseases have replaced acute infections as the major causes of death. Today, death in the United States is largely reserved for the elderly, with three-fourths of all deaths in the 65 and older age group (Gorina et al., 2006).

The world's elderly population is increasing at an unprecedented rate and according to recent reports it would account for 14 percent of the total global population by the year 2040 (Kinsella and He, 2009). This aging phenomenon has led to a significant rise in the chronic disease rate compared to other human pathologies (Panaszek et al., 2009). The most prominent age-related chronic diseases are: heart disease, stroke, cancer and dementia (Prince et al., 2008).

Alzheimer's disease (AD) is the most common form of dementia. Dementia is a broad term that's describes several symptoms related to the decline of a person's cognitive abilities. AD accounts for at least 60% of the cases of dementia in patients older than 65 (Tedeschi et al., 2008). The greatest known risk factor for AD is increasing age; the likelihood of developing AD doubles approximately every five years after the age of 65, and after age 85 the risk reaches nearly 50 percent (Alzheimer's Association, 2008).

AD has grown to be one of the most prevalent leading causes of death in Europe and the USA next to cancer, cardiovascular disease and stroke (Figure 1; Alzheimer’s Association, 2008). AD is the 7th leading cause of death in the United States for all ages and 5th in adults over the age of 65, claiming more than 70 thousand lives per year (Kung et al., 2008; Alzheimer’s Association, 2008).

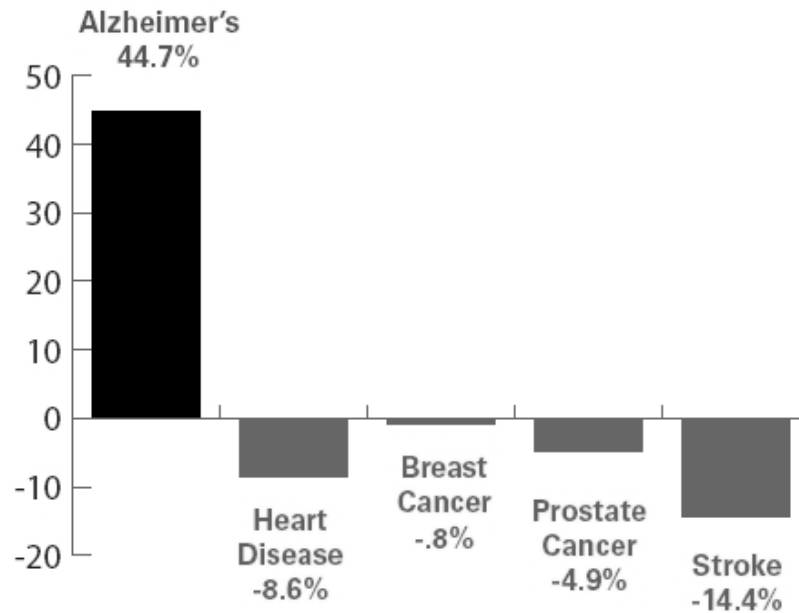

Figure 1. Percentage change in Leading Cause of Death from 2000 to 2005 (Alzheimer’s Association, 2008)

AD death rates increased from 1979 to 1988 due to improvements in diagnosis, awareness of the condition within the medical community and other unidentified factors. In 1999, after a change of the disease classification system, from ICD–9 to ICD–10 (ICD stands for International Classification of Diseases), nearly all deaths previously classified as pre-senile dementia shifted into the AD category. This and other clarifications of the diagnosis increased the number of AD deaths in 1999 compared with 1998 by 58% (Figure 2). Since the clarification of the diagnosis in 1999, the AD death rate has increased consistently by 7–9 percent each year (Kung et al, 2008).

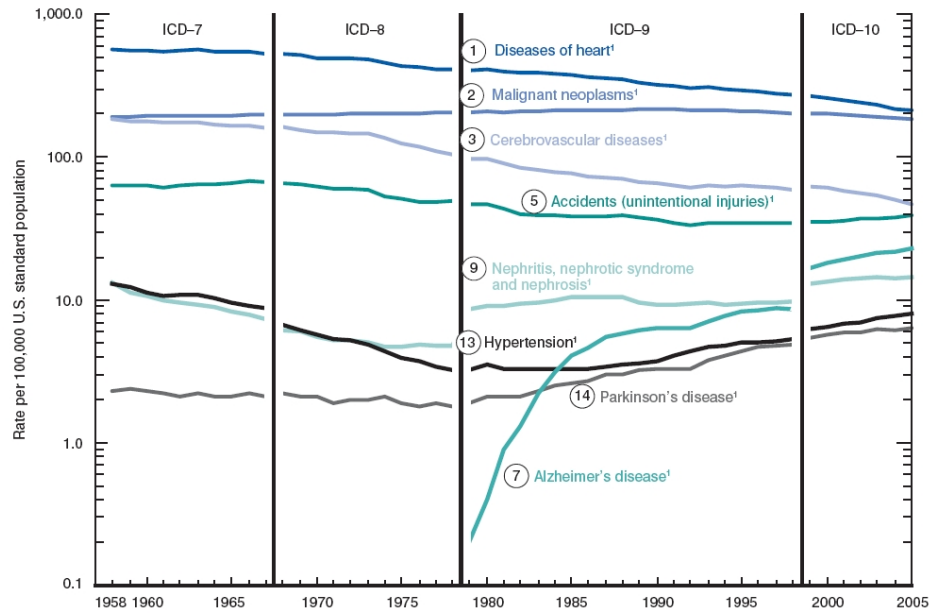

Figure 2. Age-adjusted death rates for selected leading causes of death: United States, 1958-2005. Circled numbers indicate ranking of conditions as leading cause of death in 2005. Age-adjusted rates per 100,000 U.S. standard population (Kung et al., 2008)

More than 90% of the AD are age-related and occur in the elderly population (Poirier, 2005). Reports indicate that women are more likely than men to develop AD, primarily because women tend to live longer and their longer life expectancy increases the time during which they could develop this condition (Figure 3) (Gorina et al., 2006).

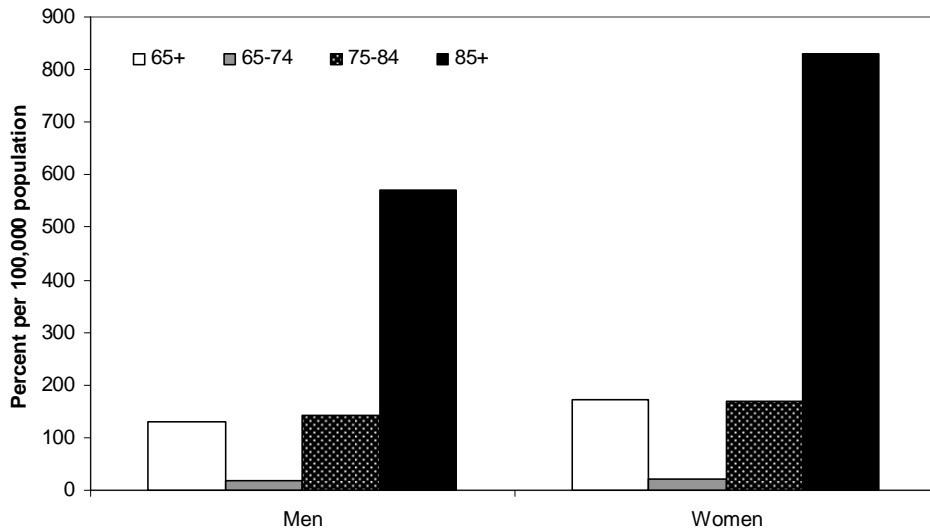

Figure 3. Death rates for AD among persons ages 65 and older by sex and age (2002) Note: The death rates for age 65+ are age-adjusted. (adapted from Gorina et al., 2006)

Alzheimer's disease

AD is an irreversible, progressive neurodegenerative disease characterized by neuronal loss in specific regions of the brain such as the hippocampus; a center for memory, and the cerebral cortex; which is involved in reasoning, memory, language and other important cognitive processes (Poirier, 2005). This gradual neuronal loss accounts for the emotional and cognitive impairment seen in the patients with this condition. AD was named after Dr. Alois Alzheimer (Figure 4.A), a German physician who in 1907 described unusual changes in the cerebral cortex of a woman who had suffered of a rare mental illness. Upon autopsy, the pathological-anatomical investigation of the brain showed the appearance of abundant plaques and abnormal neurofibril tangles (Goedert and Ghetti, 2007). Today it is well known that AD is accompanied by three main structural changes in the brain: diffuse loss of neurons, intracellular protein deposits termed neurofibrillary tangles (NFT) and extracellular protein deposits known as amyloid (A β) or senile plaques (Figure 4.B) (St George-Hyslop, 2000). As AD progresses, synaptic afferent systems degenerate resulting in dendritic and neuronal damage and the formation of abnormal protein aggregates throughout the brain (Parihar and Hemnani, 2004). Neuropathological studies have suggested that the onset and progression of this disease is related to either A β or NFT increased production, delay or impairment of their clearance, a failure in repairing the resulting damaged neurons or a combination of all three events (Parihar and Hemnani, 2004; Irvine et al., 2008).

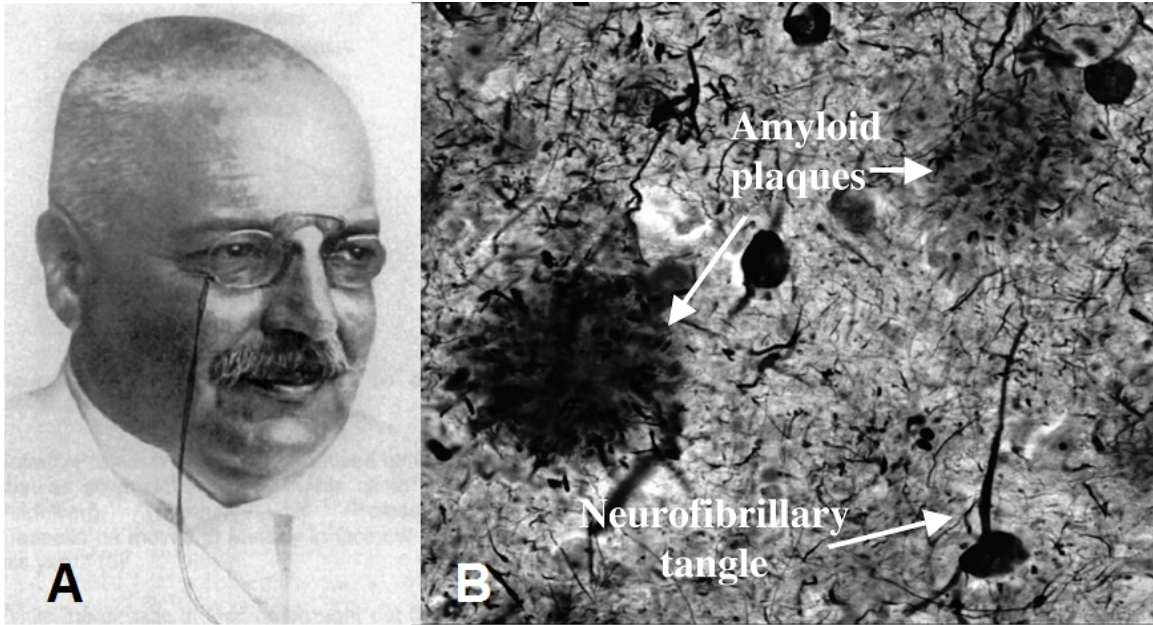

Figure 4. (A) Alois Alzheimer (1864–1915) (Goedert and Ghetti, 2007). (B) Pathological hallmarks of Alzheimer’s disease: tangles and plaques (Irvine et al., 2008).

The NFT consist of hyperphosphorylated tau protein. The primary function of tau is to maintain microtubule stability. Microtubules provide support as well as routes for nutrients and cellular components to move through cells. In AD, aggregated tau reduces its ability to bind to microtubules affecting its function (Parihar and Hemnani, 2004). Tangles of tau, however, are not unique to AD and for that reason many investigators have not considered disruptions of tau to be as important as the second kind of protein deposits observed in AD: the amyloid plaques (Yankner and Lu, 2009).

A β protein deposits, unlike NFT, accumulate extracellularly. A β plaques are one of the first hallmarks of Alzheimer’s disease to appear (Irvine et al., 2008). It is unclear whether the neurons in or near these plaques function normally, because the density of plaques is only weakly correlated with the severity of dementia. Such plaques are present in most elderly people, however, they appear before NFT and their extensive presence in

the hippocampus and the cerebral cortex is specific to AD patients (St George-Hyslop, 2000). In addition to this, all mutations of genes associated with familial AD lead to an increase of A β (Irvine et al., 2008).

Familial versus late-onset AD

Research done in the 1980s showed that certain families were at increased risk of developing AD (Goate et al., 1989). The study of these rare inherited forms of AD resulted in the discovery of the causative gene defects (Goedert and Spillantini, 2006). Epidemiologists also tracked the occurrence of AD in people who were not from such families, establishing that genetics were not the sole cause of the disease in the general population. Consequently, two forms of AD have been described; the early onset or familial AD and the sporadic or late onset AD, which is responsible for more than 90% of the cases and occurs primarily in the aging population (Parihar and Hemnani, 2004). Familial AD symptoms usually begin to appear between the early 40s and mid-50s, this form of AD is very rare, accounting for less than 5 percent of all cases.

Researchers have identified four mutations, or variant forms, of genes associated with AD. Three of these genes, located on chromosomes 1, 14 and 21, are linked to the early-onset form of AD, while the fourth gene, on chromosome 19, is linked to a greater risk of susceptibility for developing late-onset AD (Bertram and Tanzi, 2008). The first of these genes to be discovered was the APP gene, found to be located on chromosome 21. Shortly after, studies indicated that chromosome 21 might carry a defect in some families with AD. It had been reported that people with Down's syndrome (trisomy 21) displayed at least some features of Alzheimer's by the age of 40. These observations

suggested that the APP gene might be the site of mutations causing some cases of AD (Eckman and Eckman, 2007). This prediction was proven in the early 1990s, when researchers identified such mutations in individuals with familial AD. Mutations in the APP gene account for only a minority of familial AD cases (Goedert and Spillantini, 2006). The concept of changes in APP processing being central to AD gained further support when investigators discovered mutations in a set of genes which interfere with the cleavage of APP by γ secretase. Disruptions in these genes, presenilin 1 and presenilin 2, which are located, respectively, on chromosome 14 and chromosome 1, cause a very aggressive form of early-onset AD. Mutations in presenilin 1 are the most common cause of familial AD.

The fourth gene, the only associated to late-onset AD is apoE ($\epsilon 4$), located on chromosome 19. The inheritance of the $\epsilon 4$ allele of apolipoprotein E (apoE) is the only well established genetic risk factor for sporadic AD, but its mode of action is not clear. Reports indicate $A\beta$ deposits are more abundant in $\epsilon 4$ -positive than in $\epsilon 4$ -negative cases (Fagan et al., 2002; Dolev and Michaelson, 2004; Manelli et al., 2004; Deane et al., 2008). In addition, apoE4 is associated with a number of other factors that may contribute to AD pathology, including low glucose usage, mitochondrial abnormalities, and cytoskeletal dysfunction (Goedert and Spillantini, 2006). ApoE- $\epsilon 4$ increases the risk of developing Alzheimer's, but it is neither necessary nor sufficient to develop the disease and therefore cannot be used as a diagnostic test. The causes of late-onset AD are not completely understood, and it is thought that it results from a combination of genetic as well as environmental factors.

Treatment and Prevention

With the continuous increase in the number of elder individuals and the increase in life expectancy, the devastating impact of AD on world wide health systems will dramatically increase in the next decades, posing a serious economical problem to our society. Even though it is clear how important and how rapidly this disease is expanding, there is currently no cure for AD and the available drugs for its treatment are only able to slow down its progression or improve its symptoms (Shah et al., 2008; van Marum, 2008; Aluise et al., 2008).

Post-mortem studies done in the early 1970s with brains from AD patients led to the finding of reduced choline uptake, reduced acetylcholine (ACh) release and loss of cholinergic perikarya from the nucleus basalis of Meynert and confirmed a substantial presynaptic cholinergic deficit (Francis et al., 1999). This resulted in the “cholinergic deficit hypothesis” which was the dominant theory in AD in the early 1980s. In this theory, many of the symptoms of dementia, especially learning difficulties, were explained by the lack of ACh. It was expected that restoring the cholinergic balance by inhibition of ACh breakdown would slow down the progression of AD and improve cognitive and general functioning (van Marum, 2008). In 1993, the U.S. Food and Drug Administration (FDA) approved the first drug for the treatment of AD, the cholinesterase inhibitor (ChEI) tacrine, soon to be followed by other ChEIs: donepezil (1996), rivastigmine (2000) and galantamine (2001).

ChEIs increase the levels of the neurotransmitter acetylcholine (ACh) by preventing its degradation. ACh is involved in synaptic plasticity, specifically in learning and short-term memory. In AD, the cholinergic system is affected due to damages to

neuronal cells that synthesize and utilize ACh, thereby reducing its availability. The availability of ACh at the synaptic level depends on two enzymes: cholinesterase and choline acetyltransferase. Cholinesterases consist of two groups: acetylcholinesterase (AChE) and butyrylcholinesterase (BuChE). All ChEIs interfere with the degradation of ACh by blocking AChE. By maintaining acetylcholine levels, these drugs may help compensate for the loss of brain cell function. Rivastigmine and tacrine also block BuChE. Theoretically, this dual action could be of importance because in AD, BuChE levels tend to be higher compared with AChE, which decreases over the course of the disease. The clinical importance of this BuChE blockade, however, has not been proven. ChEIs are approved for use in patients already diagnosed with AD and must not be used in patients at risk for AD or in the pre-clinical stage of mild cognitive impairment (MCI). In terms of overall effect, most experts believe cholinesterase inhibitors may delay or slow the worsening of symptoms for about six months to a year. ChEIs cannot reverse AD and will not stop the neurodegeneration. As a result, their ability to improve symptoms eventually declines as the disease progresses.

In 2003 the FDA approved memantine, another type of drug for the treatment of AD. Memantine works as a N-methyl-D-aspartate (NMDA) receptor antagonist with low to moderate affinity. Memantine appears to work by regulating the activity of glutamate (Glu). Glu is the most abundant excitatory neurotransmitter in the mammalian nervous system and is found in the neural pathways associated with learning and memory. Abnormal levels of Glu may be responsible for neuronal cell dysfunction and eventual cell death observed in AD. Memantine seems to restore the function of damaged nerve cells and reduces abnormal excitatory signals by the modulation of NMDA receptor

activity. It is thought to block selectively the effects associated with abnormal transmission of the neurotransmitter Glu, while allowing for the physiological transmission associated with normal cell functioning. The clinical efficacy of memantine, which has been approved for treatment of moderate to severe AD, seems to be less than that of the ChEIs. It is increasingly being used as adjuvant to ChEI therapy as studies indicate that targeting both the cholinergic and glutamate pathway could result in better clinical outcomes (van Marum, 2008).

Generic	Brand	Approved For	Side Effects
donepezil	Aricept	All stages	Nausea, vomiting, loss of appetite and increased frequency of bowel movements.
galantamine	Razadyne	Mild to moderate	Nausea, vomiting, loss of appetite and increased frequency of bowel movements.
memantine	Namenda	Moderate to severe	Headache, constipation, confusion and dizziness.
rivastigimine	Exelon	Mild to moderate	Nausea, vomiting, loss of appetite and increased frequency of bowel movements.
tacrine	Cognex	Mild to moderate	Possible liver damage, nausea, and vomiting.

Table 1. AD treatment chart

The causes of late-onset AD are not completely identified but are thought to result from a combination of genetic and environmental factors. AD is a complex disease and attempts to identify the environmental factors that might influence this disease, alone or in combination with genetic mutations, have not been conclusive. Epidemiological studies suggest that other types of treatments, such as antiinflammatory agents (including

NSAIDs), cholesterol-lowering drugs, hormone replacement therapy, nutritional supplements and antioxidants, may prevent or improve AD, but the results have been uncertain (Shah et al., 2008).

Many scientists also consider prevention one of the most exciting recent developments in dementia research. A growing body of evidence suggests that the health of the brain is closely related to the overall health of the cardiovascular system. Some data indicate that the management of cardiovascular risk factors, such as high cholesterol, type 2 diabetes, high blood pressure and overweight, may help avoid or delay cognitive decline. Additional evidence points to a significant role for regular physical exercise in maintaining lifelong cognitive health. More limited data suggest that a low-fat diet rich in fruits and vegetables may support brain health, as well as a robust social network and a lifetime of intellectual curiosity and mental stimulation (Alzheimer’s Association, 2008).

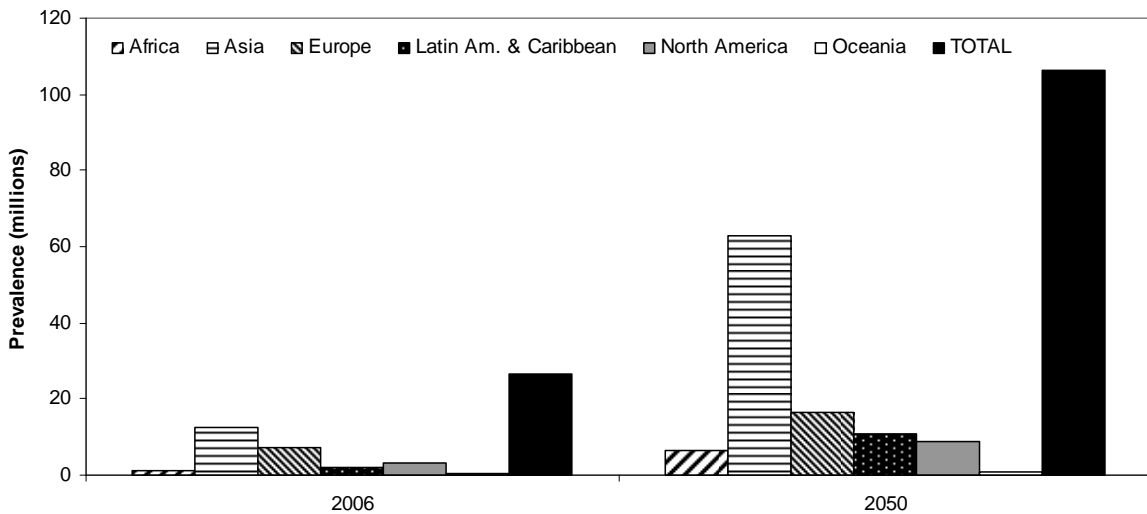

Figure 5. Projections of AD disease prevalence by regions. (adapted from Brookmeyer et al., 2007) *Note:* Regions defined according to the United Nations Population Division, Oceania includes Australia, New Zealand, Melanesia, Micronesia, and Polynesia

AD claims more than 70000 lives per year (Kung et al., 2008). A recent publication shows that between the years 2000 and 2050 there will be an approximate 3-fold increase in the number of cases (Figure 5) (Brookmeyer et al., 2007). The number of individuals with AD will continue to increase unless new discoveries facilitate the prevention of this disease, delaying the onset by five years could reduce the number of individuals with AD by approximately 50%, making the study of this neurodegenerative disease a medical priority.

CHAPTER 2

AMYLOID BETA

The Amyloid Cascade Hypothesis

The two major hypotheses proposed to explain the molecular mechanisms behind AD are the cholinergic hypothesis and the amyloid cascade hypothesis (Bartus et al., 1982; Hardy and Allsop, 1991). As discussed on Chapter 1, cholinergic deficits represent a significant part of AD etiology, but cannot fully explain the neuropathological features observed in this disease (Parihar and Hemnani, 2004). Alternatively, the amyloid cascade hypothesis states that the neurodegenerative process seen in AD is caused by a series of events triggered by the atypical processing of the amyloid precursor protein (APP), which leads to the production of plaque-forming amyloid beta ($A\beta$) (Checler and Vincent, 2002; Robinson and Bishop, 2002). Elevations of these $A\beta$ forms eventually lead to tau hyperphosphorylation and other histological and clinical features of AD (Figure 1). Evidence, which includes the $A\beta$ deposition seen in AD brains, the toxic properties of $A\beta$ to neurons *in vitro*, and the identification of mutations of APP in familial early onset AD, has supported the amyloid cascade hypothesis.

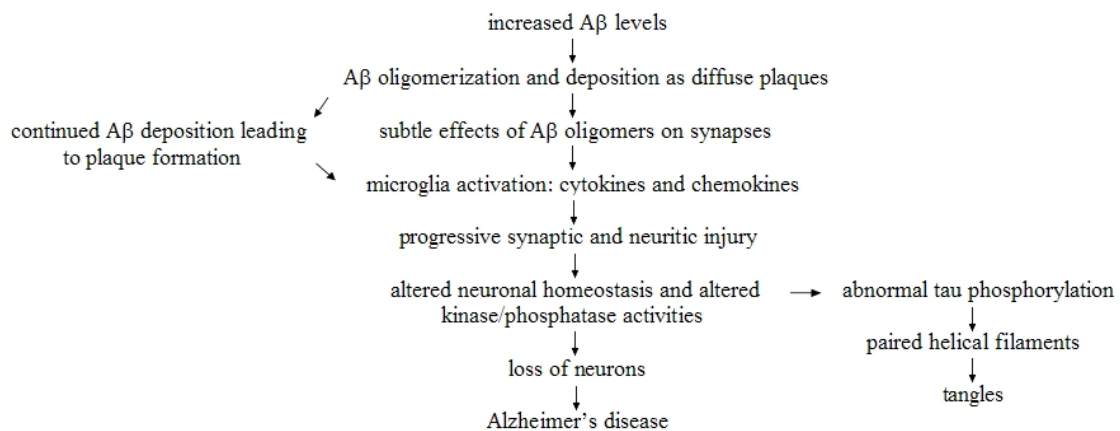

Figure 1. Amyloid cascade hypothesis (adapted from Irvine et al., 2008)

APP Processing

APP is part of a family of ubiquitously expressed glycosylated transmembrane proteins; these are most abundantly expressed in the brain (Roßner, 2004). APP is reported to occur in three common isoforms; APP695, APP751, and APP770. APP695 is expressed exclusively in neurons and is the most abundant APP transcript in the brain (Neve et al., 1988). APP function is not well defined but it is thought to be important in maintaining neuronal health (Thinakaran and Koo, 2008).

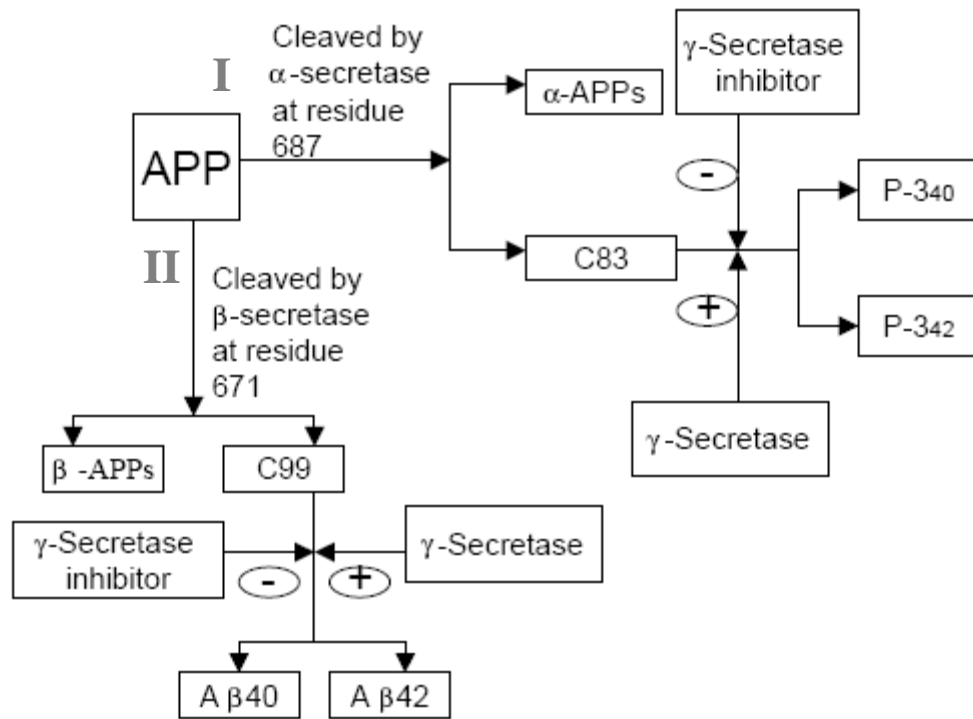

Figure 2. Schematic diagram of APP processing and production of Aβ (Parihar and Hemnani, 2004)

Several lines of evidence have revealed that APP is cleaved in one of two ways; it either follows a non-amyloidogenic (I) or an amyloidogenic (II) pathway (Figure 2). The non-amyloidogenic is considered the typical pathway, where α-secretase cleaves APP resulting in the release of a fragment called α-APPs. This fragment may have beneficial

properties, such as promoting neuronal growth and survival. The remaining APP fragment, still attached to the neuron's membrane, is then cleaved by γ -secretase. The smaller of the resulting fragments, called p3, is also released, while the larger fragment remains within the neuron and is believed to enter the nucleus. No A β is produced in this pathway (Weidemann et al., 1989; Haass et al., 1992a,b; Sisodia, 1992). For the amyloidogenic pathway (II), β -secretase (also called β -site APP-cleaving enzyme or BACE1) cleaves the APP molecule releasing a fragment called β -APPs (Parvathy et al., 1999; Sinha and Lieberburg, 1999; Vassar et al., 1999). Then, γ -secretase cleaves the remaining fragment and A β is released (Figure 3) (Golde et al., 1992; Seubert et al., 1993; Roßner, 2004).

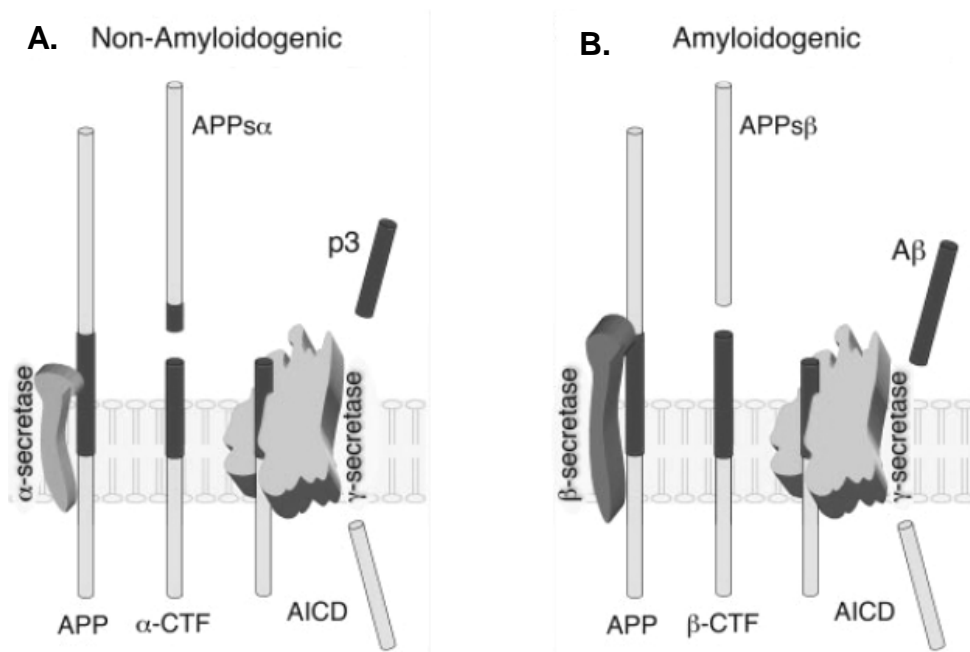

Figure 3. Proteolytic processing of APP. (A) Non-amyloidogenic. Sequential processing of APP by membrane-bound α and γ -secretases. α -secretase cleaves within the A β domain, thus precluding generation of intact A β protein. The fates of N-terminally truncated A β (p3) and AICD are not fully resolved. **(B) Amyloidogenic processing of APP.** Sequential action of membrane-bound β and γ -secretases. CTF: C-terminal fragment, AICD: APP intracellular domain. (Thinakaran and Koo, 2008).

The presence of A β itself does not lead to neurodegeneration; A β is a normal product of APP's cleavage and is naturally present in the brain and cerebrospinal fluid (CSF) (Haass et al., 1992a; Vigo-Pelfrey et al., 1993; Walsh et al., 2000; Irvine et al. 2008). A β is produced physiologically and its concentration is tightly controlled by biosynthesis and catabolism rates (Haass and Selkoe, 1993; Sisodia and Prince, 1995; Checler, 1995; Octave, 1995; Checler and Vincent, 2002). At equilibrium, A β is likely to remain below its threshold of solubility, but mutations, certain environmental conditions or other effectors could alter this steady-state. It is when its equilibrium is disturbed that A β begins to aggregate. These small, soluble A β clusters are called oligomers. It is likely that some oligomers are cleared from the brain. If they cannot be cleared, they clump together, with other proteins or with cellular material. As the process continues, these clumps grow larger, becoming increasingly insoluble entities called protofibrils and fibrils (Figure 4). Eventually they coalesce into the well-known plaques which are characteristic of AD; the amyloid plaques (Irvine et al., 2008).

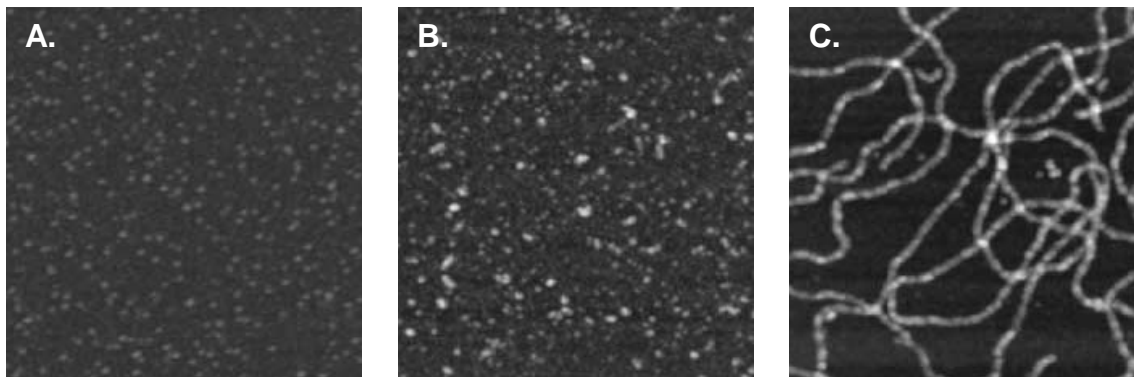

Figure 4. Morphology of A β assemblies. AFM analysis of HFIP-treated, lyophilized A β_{1-42} resuspended at a concentration of 5mM in DMSO (**A**: unaggregated) or incubated at 100uM concentration for 24 h in either culture medium at 4°C (**B**: oligomeric) or 10mM HCl at 37°C (**C**: fibrillar). Samples were diluted to 10 uM concentration for AFM analysis. Representative 1x1 um x-y, 10 nm total z-range AFM images (modified from Klein et al., 2004).

Forms of A β

Depending on the exact point of cleavage by β -secretase, two predominant forms of A β are produced; these consist of either 40 or 42 amino acid residues. Under normal conditions most of the A β proteins contain 40 amino acids but APP mutations can lead to an increased production of the 42-amino acid form (Citron et al., 1992; Goedert and Spillantini, 2006; Thinakaran and Koo, 2008). The ratio of A β_{1-42} to A β_{1-40} is particularly important, since the longer form of A β is more prone to oligomerize and produce fibrils than the more abundantly produced A β_{1-40} protein (Suzuki et al., 1994). A β_{1-42} has also been shown to be more neurotoxic than A β_{1-40} (Figure 5) (Klein et al., 2004). As mentioned earlier, production of A β is a normal process, but in a small number of individuals the overproduction or increased proportion of A β_{1-42} appears sufficient to cause early-onset AD (St George-Hyslop, 2000; Irvine et al., 2008).

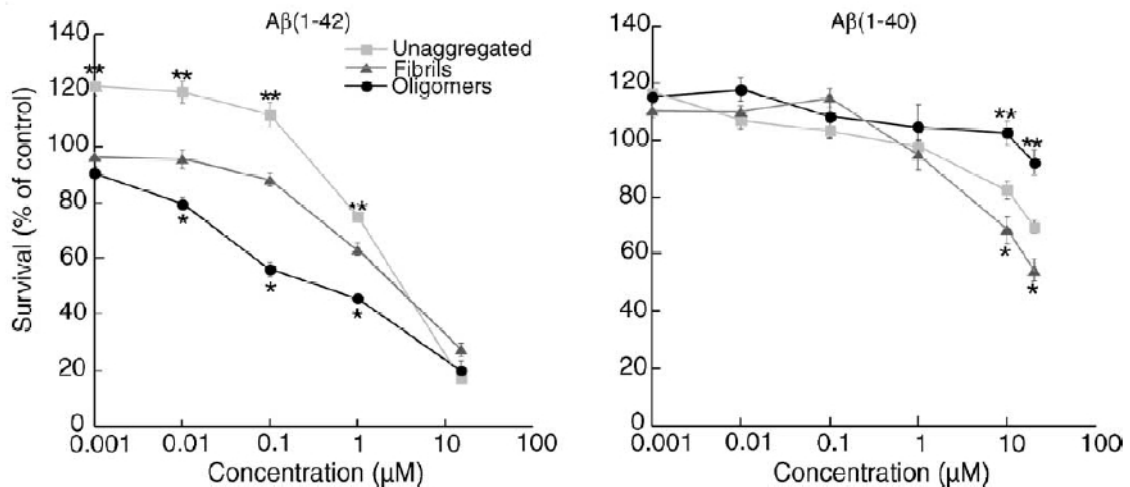

Figure 5. Effect on neuronal viability of different forms of A β_{1-42} and A β_{1-40} . A β proteins were incubated with Neuro-2A cells for 20 h. The MTT assay was used as an indicator of cell viability. Graph represents the mean \pm S.E.M. for $n = 8$ from triplicate wells from at least two separate experiments using different A β preparations. *: Significant ($p < 0.01$) difference between oligomers and fibrils. **: Significant ($p < 0.01$) difference between unaggregated and both oligomers and fibrils (Klein et al., 2004).

A β Structure and Toxicity

The A β cascade hypothesis has been the predominant hypothesis in the field for more than 15 years, and has provided a starting point for multiple AD therapeutic strategies (Hardy and Allsop, 1991; Wirths et al., 2004). However, this hypothesis has been controversial, as there is a relatively weak correlation between the severity of dementia and the density of the amyloid plaques (Terry et al., 1991; Aluise et al., 2008; Hardy, 2009). In contrast, there appears to be a very strong one between the levels of soluble A β and the extent of synaptic loss and severity of cognitive impairment (McLean et al., 1999; Kim et al., 2003; Tabaton and Piccini, 2005; Watson et al., 2005; Irvine et al., 2008). The term soluble refers to all forms of A β that remain in aqueous solution following high speed centrifugation of brain extracts (Irvine et al., 2008). Soluble oligomers range from dimers and trimers to dodecamers, also called A β -derived diffusible ligands (ADDLs) (Lambert et al., 1998; Walsh et al., 2002; Klein et al., 2004; Eckman and Eckman, 2007).

In recent studies, antibodies reported to be specific for oligomeric, but not monomeric or fibrillar A β , revealed abundant anti-oligomer reactivity in soluble extracts of AD brains, but none in age-matched controls (Georganopoulou et al., 2005). Studies suggest that low molecular weight oligomers are the most toxic A β form (Kirkitadze et al., 2002; Heinitz et al., 2006; Tamagno et al., 2006; Yankner and Lu, 2009; Roychoudhuri et al., 2009). Even though these oligomeric forms appear to be the main culprit in AD, it is very likely that in the human brain various forms of A β are simultaneously altering neuronal, astrocytic and microglial function, affecting multiple regions of the cerebral cortex (Irvine et al., 2008).

CHAPTER 3

ASTROCYTES AND AD

Astrocyte Function

Not until recently have glial cells (astrocytes, oligodendrocytes and microglia) been considered to be more than just structural cells. It is now widely recognized that they do much more; they help maintain the extracellular environment and stabilize cell to cell communications in the CNS (Maragakis and Rothstein, 2006). Astrocytes are the most abundant cells in the CNS, comprising close to 90% of the brain mass (Gee and Keller, 2005; Farfara et al., 2008). These cells participate in the regulation of cerebral blood flow, maintenance of synaptic function, neuronal metabolism, as well as neurotransmitter synthesis and neuronal repair (Helmuth, 2001; Danbolt, 2001; Haydon, 2001; Voutsinos-Porche et al., 2003; Ye et al., 2003; Simard and Nedergaard, 2004; Takano et al., 2006; Farina et al., 2007; De Keyser et al., 2008). Understanding these functions is helping shed light on the role of astrocytes in neurodegenerative diseases like AD.

After brain injury or in neurodegenerative conditions, such as AD, it has been observed that glial cells are activated (Akiyama et al., 2000; Ladu et al., 2001). This activation is considered to be the first defense mechanism against pathological abnormalities occurring in neurodegenerative diseases (Escratin and Bonvento, 2008; Farfara et al., 2008). The activated astrocytes seen in AD brains appear to be closely associated with the amyloid plaques, suggesting a central role of these non-neuronal cells in AD pathology (Griffin et al., 1989; Wisniewski and Wegiel, 1991; Van Eldik and

Griffin, 1994; Wyss-Coray et al., 2003; Maragakis and Rothstein, 2006). The astrocytic response to A β is expressed as an increase in the number and volume of astrocytic processes in the area of contact with fibrillar A β (Wegiel et al., 2000; Meda et al., 2001). Although activated astrocytes may mediate some inflammatory effects caused by A β , studies show that these cells are also involved in the clearance of A β from the central nervous system (CNS) (Wyss-Coray et al., 2003; Pihlaja et al., 2008). Reports of astrocytes binding to A β , clearing it from neurons and internalizing it, indicate that these cells play a protective role in AD (Guenette, 2003; Wyss-Coray et al., 2003; Paradisi et al., 2004; Pihlaja et al., 2008; Nielsen et al., 2009). Evidence indicates that these protective processes in astrocytes are dependant on apolipoprotein E (apoE), the most abundant apolipoprotein in the CNS (Hu et al., 1998; Ladu et al., 2000a; Koistinaho, 2004).

ApoE Synthesis and Function

ApoE is a polymorphic protein with 299 amino acids and a molecular weight of 34 kDa (Strittmatter and Bova Hill, 2002). ApoE was first identified in 1973 as a serum protein that mediates extracellular cholesterol transport (Mahley, 1988). ApoE plays an important role in the distribution and metabolism of cholesterol and triglycerides within many organs and cell types (Ribalta et al., 2003; Hatters et al., 2006). Although ApoE is considered mostly a lipid transport molecule, work done in the past few years suggests it plays additional roles in the brain; regulating both astrocyte and neuronal function (Weisgraber et al., 1994; Poirier, 2000; Gee and Keller, 2005; Levi et al., 2005).

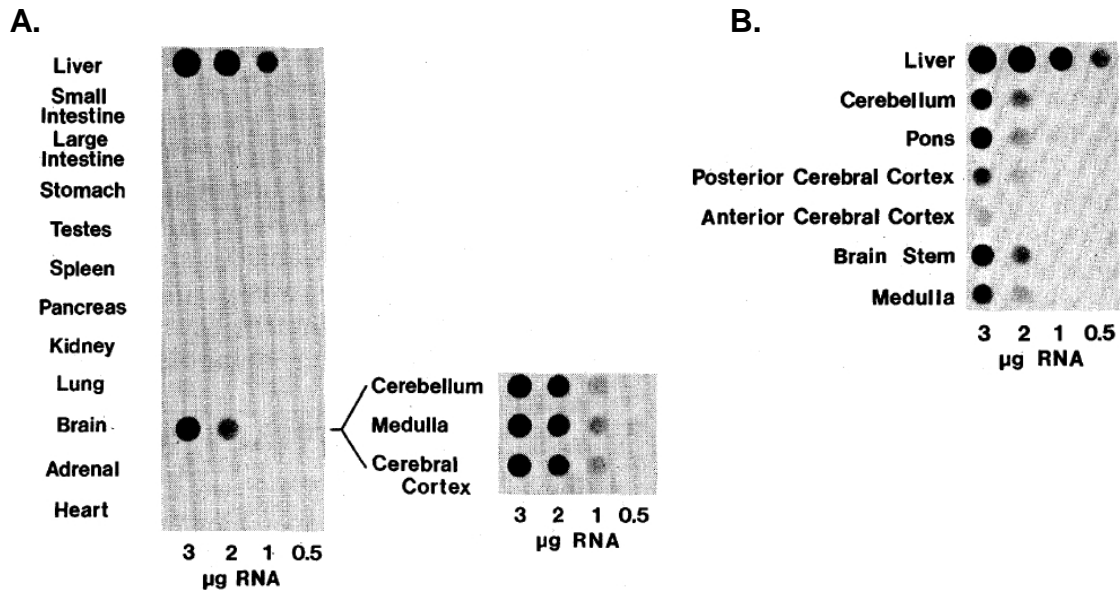

Figure 1. Distribution of apoE mRNA in different tissues. Total cellular RNA from each whole tissue was examined by dot blot hybridization method. Cloned, homologous, ^{32}P -labeled cDNA probes were employed for Simonsen rat (A) and human (B) tissue. Several autoradiogram exposures of hybridized filters were made and analyzed by quantitative scanning densitometry. Typical autoradiogram exposures are shown (Elshourbagy et al., 1985).

The brain is second only to the liver in the abundance of apoE mRNA (Figure 1) (Elshourbagy et al., 1985; Zheng et al., 2004). In the brain, apoE has been shown to regulate neurotransmission, immune response as well as growth factor release (Gutman et al., 1997; Muller et al., 1998; Fagan and Holtzman, 2000; Misra et al., 2001; Aono et al., 2002; Grainger et al., 2004; Lee et al., 2004). The mechanisms behind apoE synthesis and secretion are not fully understood, but it is well known that in the brain apoE is predominantly synthesized and secreted by astrocytes (Boyles et al., 1985; Pitas et al., 1987).

In humans, three isoforms of apoE have been reported; apoE2, apoE3, and apoE4. These isoforms are all products of the same gene with three alleles ($\epsilon 2$, $\epsilon 3$, and $\epsilon 4$) at a single gene locus on chromosome 19 (Lin - Lee et al., 1985; Huang, 2006).

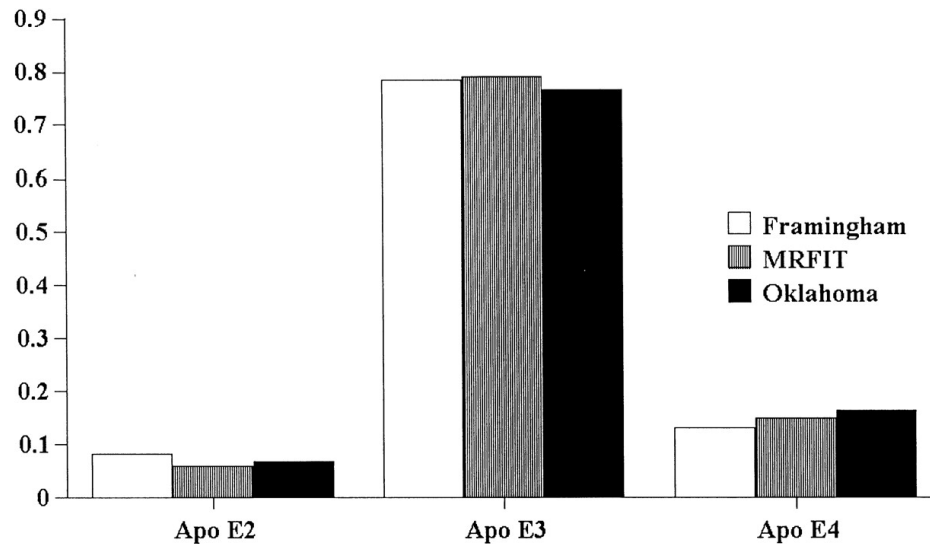

Figure 2. Comparison of apoE gene frequencies. Frequencies were determined by apoE protein electrophoresis in three US studies: Framingham Offspring Study, Framingham, Massachusetts, offspring of the Framingham Heart Study cohort (n = 1123 Caucasian men); Multiple Risk Factor Intervention Trial (MRFIT), participants selected from the original cohort involving 22 clinical centers in the United States (n = 619 Caucasian men; primary prevention trial of at-risk middle-aged men) and Oklahoma Angiography Cohort, Oklahoma City, Oklahoma, coronary heart disease patients with at least one vessel disease (n = 505 Caucasian men; hospital based, 1992–1994) (Eichner et al., 2002).

In general, the $\epsilon 3$ allele accounts for the vast majority of the apoE gene pool (typically 70-80%), the $\epsilon 4$ allele accounts for only 10-15% and the $\epsilon 2$ allele for 5-10% (Figure 2).

The molecular basis for apoE polymorphism has been elucidated by amino acid sequence analysis. All of these isoforms are identical in their primary sequence except at amino acids 112 and 158. ApoE2 has cysteines at these positions, apoE4 has arginines and apoE3 has cysteine at position 112 and arginine at 158 (Table 1) (Weisgraber et al., 1981; Rall et al., 1982; Strittmatter and Bova Hill, 2002). This substitution affects their three-dimensional structure and lipid-binding properties (Wu et al., 1998; Michikawa et al., 2000; Hatters et al., 2006; Cedazo-Mínguez, 2007). The amino acids at these two positions are ultimately responsible for the isoform-specific effects of apoE in diseases that affect the cardiovascular system and the CNS (Strittmatter and Bova Hill, 2002;

Evans et al., 2004; Fazekas et al., 2006; Rapp et al., 2006; Martínez-González and Sudlow, 2006).

Isoform	Average allelic frequency (%)	Amino acid variation (residue)		Functional differences		Structural differences		Associated disorders
		112	158	LDL receptor affinity	Lipoprotein-binding preference	Conformational stability and folding behavior	Domain interaction?	
ApoE2	7	Cys	Cys	Low	HDL	Most stable and lacks folding intermediates	No	Type III hyperlipoproteinemia
ApoE3	78	Cys	Arg	High	HDL	Intermediate stability with folding intermediates	No	Unknown
ApoE4	15	Arg	Arg	High	VLDL LDL	Least stable with folding intermediates	Yes	Alzheimer's disease and other neurological conditions; atherosclerosis

Table 1. Prevalence of the human apoE isoforms and their key differences (Hatters et al., 2006).

Multiple studies have demonstrated isoform-specific effects of apoE on neurite outgrowth, neuronal plasticity, neurotoxicity, lipid peroxidation, oxidative injury, binding to cytoskeletal proteins as well as interactions with plaque-forming A β (Aleshkov et al., 1997; Fagan and Holtzman, 2000; Holtzman et al., 2000; Tokuda et al., 2000; Nathan et al., 2002; Dodart et al., 2005). ApoE4, as discussed on Chapter 1, is the major genetic risk factor for developing AD, while apoE2 appears to be protective (Strittmatter et al., 1993; Oyama et al., 1995; Fagan et al., 2002; Frey et al., 2006; Cedazo-Mínguez, 2007).

ApoE and AD

Increased apoE mRNA levels have been observed after CNS injury as well as in the brains of AD mouse models and AD patients (Ignatius et al., 1986; Yamada et al., 1995; Zarow and Victoroff, 1998; Ladu et al., 2001; Haasdijk et al., 2002; Seitz et al., 2003; Cedazo-Mínguez, 2007). Several lines of evidence suggest that apoE's upregulation might be associated with its role in downregulating astrocyte activation as

well as in preventing and repairing the neuronal damage caused by A β (Lynch et al., 2001). The exact mechanism by which apoE influences the onset and progression of AD is not completely understood. It is clear that apoE's link to AD is strongly associated with its interaction to A β , a connection that makes the study of this relationship particularly important.

Several *in vitro* and *in vivo* studies have shown that apoE influences brain A β metabolism, deposition, toxicity, fibril formation and clearance (Dolev and Michaelson, 2004; Koistinaho et al., 2004; Deane et al., 2008). ApoE also inhibits A β -induced neurotoxicity and inflammation (Hu et al., 1998; Fagan et al., 2002; Manelli et al., 2004; Manelli et al., 2007). ApoE has an influence over A β effects and, in a reciprocal manner, A β alters apoE homeostasis. Reports have confirmed A β 's effects on astrocytic apoE levels by showing an increase in cell-associated apoE levels after A β exposure (Ladu et al., 2000b; Ladu et al., 2001, Igbavboa et al., 2003; Kimura et al., 2004; Igbavboa et al., 2006). It is possible, that in early AD apoE is upregulated, its production increased and its neuroprotective function enhanced, but, when A β starts aggregating and forming plaques, apoE can no longer function properly. Shedding light on the relationship between A β and apoE can clarify their role in AD progression and possibly show a mechanism that could help fight this fast growing disease.

CHAPTER 4

$A\beta_{1-42}$ INCREASES APOE LEVELS IN MOUSE PRIMARY ASTROCYTES

Introduction

As discussed in Chapter 3, several groups, including our own, have shown that $A\beta$ has an effect on astrocytic apoE levels (Ladu et al., 2000b; Ladu et al., 2001, Igbavboa et al., 2003; Kimura et al., 2004). Early work done by our research group reported that $A\beta$ alters cellular cholesterol dynamics, specifically cholesterol trafficking in DITNC1 rat astrocytes, effects that were associated with increased apoE levels (Igbavboa et al., 2003). $A\beta_{1-42}$ effects on cholesterol distribution and apoE levels were dependent on the type of $A\beta$ used; fresh or aged (Figure 1). Fresh $A\beta$ refers to a soluble, mainly monomeric-dimeric form, while aged refers to an aggregated form, mainly tetrameric (Figure 2.A).

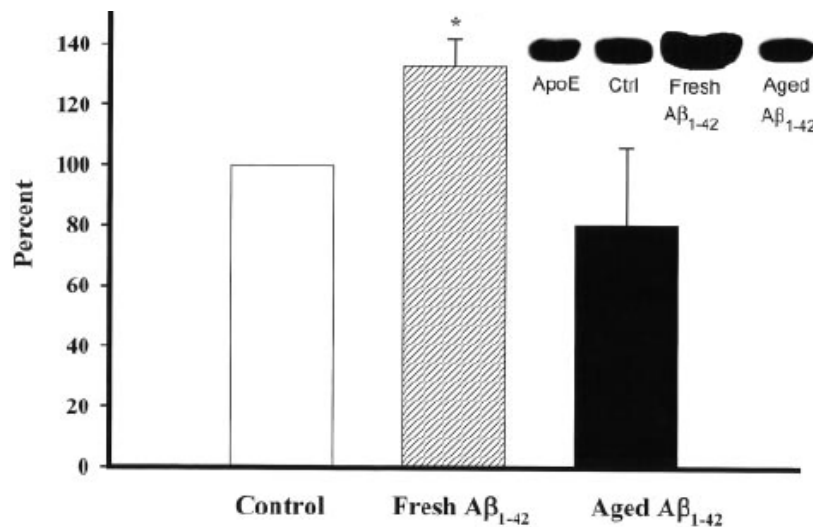

Figure 1. Fresh $A\beta_{1-42}$ but not aged $A\beta_{1-42}$ increases apoE levels in DITNC1 rat astrocytes. Cells were treated for 2h with 1uM of fresh or aged $A\beta_{1-42}$. ApoE levels were quantitated from three to four independent western blots. Data relative to control cells, means \pm S.E. *Inset*: western blot from a representative sample. * $p \leq 0.01$ as compared with control. (Igbavboa et al., 2003).

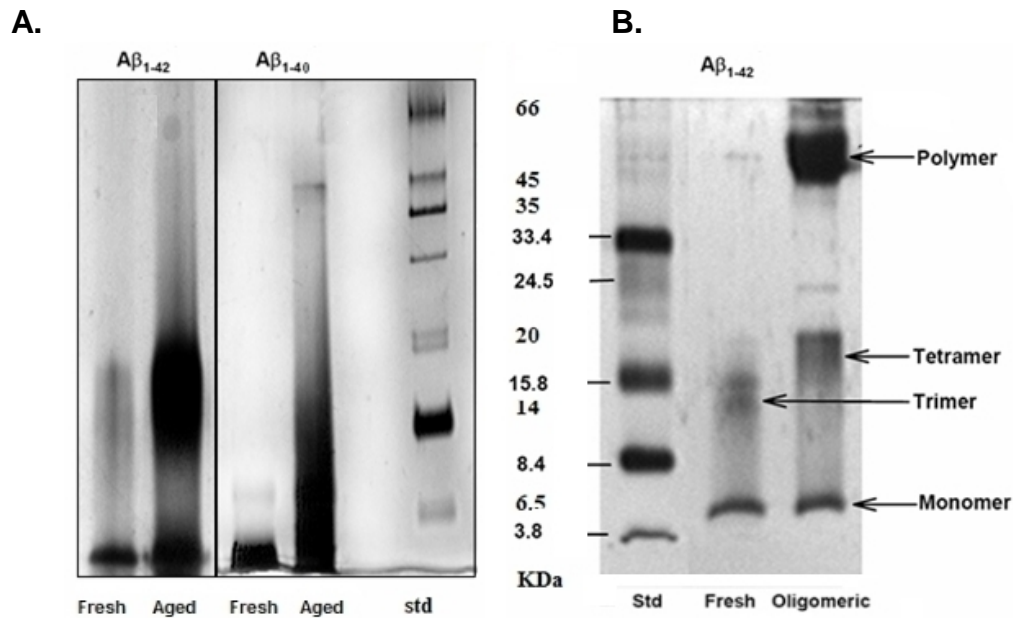

Figure 2. Aggregation of $A\beta_{1-42}$ and $A\beta_{1-40}$. **A.** $A\beta$ peptides were incubated in 1 mL of distilled water for 0 (fresh) or 48 h (aged) in darkness with continuous shaking at 37 °C. The samples were examined by electrophoresis on 11.5% nondenaturing gels (Mason et al., 1999). **B.** Fresh and oligomeric $A\beta_{1-42}$ samples were mixed with glycerol and examined by electrophoresis on 15% nondenaturing gels (Igbavboa et al., 2009).

Others have also reported an increase in astrocytic apoE protein levels after $A\beta$ exposure, however, the results have been difficult to compare due to differences in the conditions used (LaDu et al., 2000b; LaDu et al., 2001; Kimura et al., 2004). All these differences appear to indicate that the relationship between apoE and $A\beta$ is dependant on several factors, particularly the form of $A\beta$ used, concentration and incubation time. It is evident that $A\beta_{1-42}$ has an important effect on apoE; what is not so clear is how is it happening. We have hypothesized that the effect of fresh $A\beta_{1-42}$ on apoE levels occurs at a transcriptional level. Here, we take a look at the effect of fresh $A\beta_{1-42}$, monomeric dimeric form, on apoE protein and mRNA expression levels in mouse primary astrocytes. This $A\beta$ is one of the earliest forms to be deposited and thus is considered to be an early marker of AD, making it particularly important in the understanding of AD development.

Material and Methods

Cell culture

Primary cortical astrocytes were prepared from 1-2 day old C57BL/6 mice. Cerebral cortices were dissected and meninges removed. Brain tissue samples were kept in cold DMEM (Invitrogen) containing 10% FBS (Invitrogen), 1% of PSN Antibiotic Mix (Invitrogen) and 0.1% of Fungin (InvivoGen) and then rinsed with DPBS (Invitrogen). The tissue was then minced and suspended in a small volume of TrypLE Express (Invitrogen) for 5-7 min at 37°C. The tissue homogenate was suspended in warm DMEM containing antibiotics/antifungal and filtered through 70 µm cell strainer. The cell suspension was then transferred to 25cm² culture flasks (average 1 brain/flask). The media was changed after 24 h and every second day from then on. When cells become confluent (around 7-10 days) they were rinsed with DPBS, suspended in TrypLE Express and subcultured at 1.25 x 10⁶ cells/75 cm² flask. When cells had reached about 80% confluence, the media was replaced with a 1% lipoprotein deficient serum (Sigma) DMEM with 0.1% PSN Antibiotic Mix (Invitrogen). The experiments were performed 24 after this pre-treatment.

All procedures using mice were conducted in accordance with the Association for Assessment and Accreditation of Laboratory Animal Care and the National Institutes of Health policies on the care and use of laboratory animals and approved by the Institutional Animal Care and Use Committee of the University of Minnesota. All efforts were made to minimize the number of animals used and their suffering.

Amyloid beta

The A β ₁₋₄₂ used was obtained from American Peptide. Fresh indicates that the A β was not preincubated prior to cell treatment. The concentration and form of A β used was based on earlier studies done by our group (Figure 1; Igbavboa et al., 2003). 1 mg of the A β protein was dissolved in 2.3 mL distilled water containing NH₄OH (1 uL of 14.8 N ammonium hydroxide in 1 mL bidistilled water). The completely solubilized preparation was used immediately without aging. Freshly prepared A β ₁₋₄₂ at a concentration of 1uM was used for all of the experiments. These A β conditions were used for all our work unless otherwise specified.

RNA isolation

After treatment, cells were rinsed with DPBS (Invitrogen), a small volume of TrypLE Express (Invitrogen) was added and then cells were scraped. TNS (Lonza) solution was added to stop enzymatic reactions and the cell suspension was collected in a pre-chilled tube. The suspension was centrifuged for 3 min at 2500 rpm, the supernatant removed and the cell pellet resuspended in a small volume of PBS and transferred to a microcentrifuge tube, centrifuged again for 2 min at 4000 rpm and if not used immediately the pellet was stored at -20°C. The cell pellet was homogenized in TRIzol reagent (Invitrogen). RNA was extracted and precipitated following the manufacturer's instructions and resuspended in nuclease-free water (Ambion). Total RNA was quantified by measuring absorbance at 260 nm.

RT-PCR and agarose gel electrophoresis

For the reverse transcription reaction, 0.15 µg of total RNA were used. RT-PCR was accomplished using the Super Script III One-Step RT-PCR System with Platinum Taq DNA Polymerase (Invitrogen) and a Bio-Rad icycler thermal cycler. The program for the thermal cycler, without a hot start, was as follows: cDNA synthesis 1 cycle at 55°C for 30 min, denaturation 1 cycle at 94°C for 2 min, PCR amplification 35 cycles; 94°C for 15 s (denature), 51.3°C for 30 s (anneal), 68°C for 1 min 30 s (extend), Final extension 68°C for 5 min, finish cycle at 4°C. The primers used were the following: apoE (503 bp) 5'-AGGATCTACGCAACCGACTC-3', 3'-GGCGATGCATGTCTTCCACTA-5' and β-actin (924bp) was used as an internal standard; 5'-GGCCCAGAGCAAGACAGGTA-3' and 3'-GGA CTCATCGTACTCCTGCT-5' (J Biol Chem. 2002. 277 (33): 29477-83). The resulting products were electrophoresed through 2% agarose gels with 8% ethidium bromide. The bands were visualized using a UVB lamp and the CCD camera of the Eagle Eye II video system and band density was quantitated by densitometry using the EagleSight software (Stratagene).

Cell lysis

After the Aβ treatment, cells were rinsed with cold DPBS (Invitrogen), a few milliliters of the DPBS were added and the cells were scraped. The cell suspension was collected in a pre-chilled 15 mL tube and centrifuged for 3 min at 1500 rpm. The cell pellet was lysed with complete RIPA buffer (Santa Cruz Biotechnology). The solution was gently rocked for 15 min on ice. The lysate was transferred to a 1.5 mL chilled tube and centrifuged at 13000 rpm for 15 minutes. The supernatant was transferred to a new tube and the protein levels measured. Protein levels were quantified by measuring the

absorbance of a 1:10 dilution of the lysate at 540 nm following the Bradford Protein Assay from Bio-Rad using BSA (Sigma) as a standard.

ApoE Western blot

For western blot analysis, 60ug of protein from the cell lysate were electrophoresed on a 10% SDS–Tricine–HCl gel. The proteins were then transferred to a nitrocellulose membrane (Bio Rad) and incubated with mouse primary monoclonal anti-mouse apoE antibody (1:500) from Abcam. Goat anti-mouse IgG:HRP conjugate (1:5000) was used as a secondary antibody (Transduction Laboratories). Immunoreactivity was visualized with SuperSignal West Pico Chemiluminescent (Pierce). Band density was be quantitated by densitometry using an Eagle Eye II video system and EagleSight software (Stratagene). Lamin (1:1000) protein levels were used as an internal standard (Santa Cruz Biotechnologies).

Data analysis

Results are based on three to four independent cell culture preparations. The difference between the groups was analyzed using Student's *t* test. Statistical significance was established at a level of $p \leq 0.05$.

Results

A β ₁₋₄₂ increases apoE protein levels in mouse primary astrocytes

Our earlier work (Figure 1) revealed that maximal A β stimulation of apoE levels occurred after a 120 min incubation period. This work had been done using DITNC1 rat astrocytes. To confirm this finding, we assessed the effects of fresh A β ₁₋₄₂ on mouse primary astrocytes. ApoE protein levels, as seen in Figure 3, were significantly increased after 1 hour of incubation. The data were normalized (apoE:lamin C ratio) and presented as the percentage increase from control.

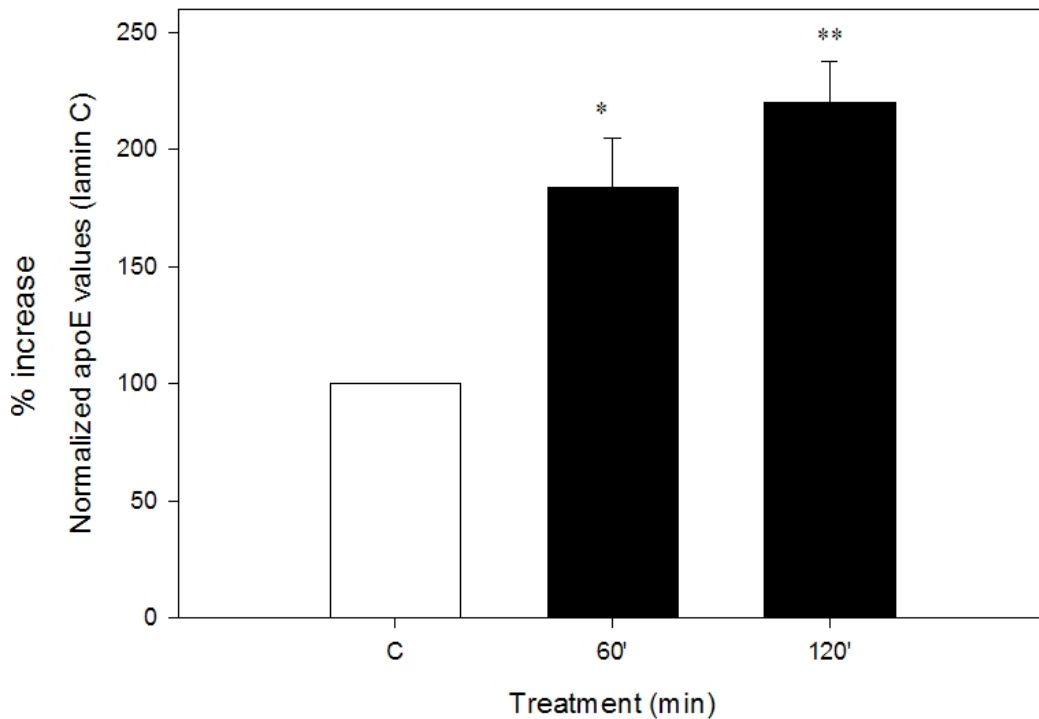

Figure 3. A β ₁₋₄₂ increases apoE protein levels in primary astrocytes. Cells were incubated with fresh A β ₁₋₄₂ (1uM) for 60 and 120 minutes. Levels of apoE protein were determined by western blot and quantified by densitometry. The data was normalized in respect to lamin protein levels (apoE:lamin C ratio) and presented as the percentage increase from control. n = 4. * $p \leq 0.01$, ** $p \leq 0.001$

A β ₁₋₄₂ increases apoE mRNA expression levels in primary astrocytes

To evaluate if the increase in apoE protein levels was due to an effect at the transcriptional level, we quantified apoE mRNA using an endpoint RT-PCR system. Mouse primary astrocytes were cultured in conditioned media containing 1 μ M of fresh A β ₁₋₄₂ protein for 15, 30, 60, 90 and 120 minutes. ApoE mRNA expression levels were normalized with respect to that of β -actin mRNA (apoE: β -actin ratio) and presented as the percentage increase from control. The expression level of β -actin mRNA was unaffected by the presence of A β (data not shown). As can be seen in Figure 3, apoE message levels show an increase in a time-dependent manner. Significant increased levels are seen after 30 min, with the peak level reached after 60 min of A β treatment (Figure 4).

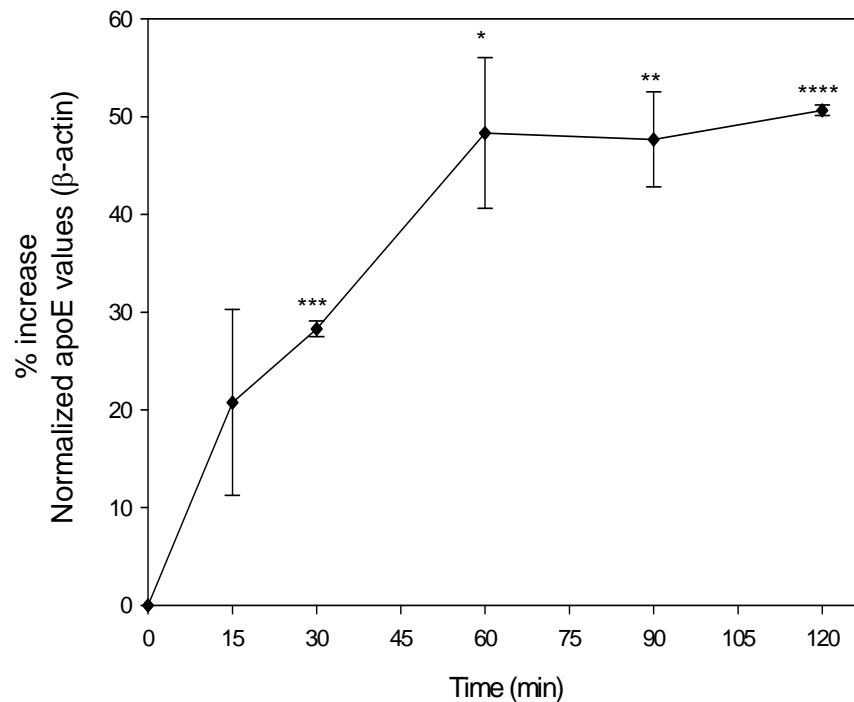

Figure 4. A β ₁₋₄₂ increases apoE mRNA expression levels in primary astrocytes Cells were incubated with fresh A β ₁₋₄₂ (1 μ M) for 15, 30, 60, 90 and 120 minutes. Levels of apoE mRNA were determined by RT-PCR and quantified by densitometry in agarose gels. n = 3. * $p \leq 0.05$, ** $p \leq 0.005$, *** $p \leq 0.0005$, **** $p \leq 0.0001$.

Discussion

It has been reported that $A\beta_{1-42}$ increases apoE abundance in astrocytes (LaDu et al., 2000b; LaDu et al., 2001; Igbavboa et al., 2003; Kimura et al., 2004). In AD, apoE's upregulation might be associated with its role in downregulating astrocyte activation as well as in preventing and repairing the neuronal damage caused by $A\beta$ (Lynch et al., 2001). It is well documented that apoE transport of cholesterol from astrocytes to neurons is important in maintaining optimal neuronal function (Göritz et al., 2002). Our group has described how fresh $A\beta_{1-42}$ affects cholesterol levels and cholesterol cell distribution in astrocytes and revealed that these effects were apoE-related (Igbavboa et al., 2003). $A\beta$'s effect on apoE and cholesterol could impact lipid trafficking within the cell and between astrocytes and neurons, affecting normal brain function (Michikawa et al., 2001; Vance et al., 2005).

The mechanisms behind the $A\beta$ -induced increase in apoE levels are not well understood. LaDu's group reported that 10 μ M of aged $A\beta_{1-42}$ increased cell-associated apoE protein levels in rat primary astrocytes but reduced its levels in the conditioned media after 12 hours of treatment. Kimura's group observed an increase in apoE protein levels after treating monkey primary astrocytes with 5 μ M of non-aggregated $A\beta_{1-42}$ for 3 days but no significant effects were seen on rat primary astrocytes or when $A\beta_{1-40}$ was used (Kimura et al., 2004). Our group has shown an increase in apoE protein levels in DITNC1 rat astrocytes after 2 hours of treatment with 1 μ M of fresh, but not aged (aggregated form) $A\beta_{1-42}$ (Igbavboa et al., 2003). It is evident that $A\beta_{1-42}$ has an important effect on apoE, what is not so clear is how this is taking place; is the increase in protein

levels associated with transcriptional regulation, changes in protein secretion, degradation or internalization?.

An important observation from LaDu's group was that aged $A\beta_{1-42}$ did not alter steady-state levels of apoE mRNA, which may indicate that this type of $A\beta_{1-42}$ is not acting at a transcriptional level but acting post-translationally on apoE turnover or impairing secretion (LaDu et al., 2000b). Yamauchi et al. have reported an increase in intracellular apoE protein levels in apoE3 expressing neuroblastoma cells after 1 h of treatment with non-aggregated $A\beta_{1-42}$ (1 μ M), but showed reduced mRNA expression levels (Yamauchi et al., 2003). They hypothesized that this effect is induced by facilitated internalization of apoE within the immortalized neurons, accompanied by enhanced clearance of extracellular $A\beta$. The differences between all of these results suggest there are several factors affecting the relationship between apoE and $A\beta$, among these are: cell type, form of $A\beta$ used, incubation time, concentration of $A\beta$ and probably, the apoE isoform that it is expressed.

It was pointed out in Chapter 3 the importance of astrocytes in normal brain function and how apoE is predominantly synthesized and secreted by these cells. The use of neurons or, in the case of the Yamauchi study, of immortalized neurons, would not seem to be the most appropriate choice for understanding the mechanisms behind $A\beta$ effects on apoE. The fact that apoE is not mainly synthesized in neurons suggests that the increase in apoE that was seen in these cells might not be associated with enhanced transcription. The form and type of $A\beta$ used is a key factor to consider. $A\beta$ is a dynamic molecule that tends to aggregate as AD progresses. It would be expected to see different cell responses depending if the form of $A\beta$ used is fresh or aged (aggregated form).

Furthermore, it has been reported that A β biological activity is directly influenced by its structure (McLean et al., 1999; Klein et al., 2004).

Fresh A β (soluble monomeric-dimeric form) is one of the earliest species of A β to be deposited and thus is considered to be an early marker of AD (Tabaton and Piccini, 2005; Watson et al., 2005; Georganopoulou et al., 2005). Studying this early form of A β could help understand the initiation of the cascade of events that lead to AD, while studying the aggregated form would be representative of a more advanced stage of the disease. The incubation time and A β concentration are also important factors to consider. A β , as we know, is a toxic molecule and longer cell exposure time as well as high concentrations will trigger an array of effects. A β_{1-42} neurotoxicity has been shown to be significantly greater with oligomeric, versus fibrillar and unaggregated, an effect that is both dose and time-dependent (Klein et al., 2004; Heinitz. et al., 2006).

Our observations in astrocytes showed that cholesterol trafficking was disrupted after 1 μ M of fresh A β treatment, this gave us an indication that apoE, a cholesterol transport molecule, could be affected, which we later proved (Figure 1; Igbavboa et al., 2003). We confirm these results in primary astrocytes (Figure 3) since many of the properties of immortalized cells have been altered and their response may differ from non-transformed cells. In order to determine if fresh A β_{1-42} could be affecting apoE synthesis in astrocytes we evaluated A β_{1-42} effect on apoE mRNA expression. We found a time-dependant increase in mRNA levels after A β treatment. A significant increase in expression levels was seen as early as 30 minutes after treatment (Figure 4), which supported the rapid increase in protein levels previously described (Figure 3). In

conclusion, our results show that fresh $A\beta_{1-42}$ increases apoE abundance in astrocytes through transcriptional activation.

It is likely that when AD starts developing, early forms of $A\beta_{1-42}$ upregulate apoE, increasing its production and enhancing its neuroprotective function, however, when $A\beta$ begins to aggregate this pathway can no longer be activated, disrupting apoE function (Brendza et al., 2002). The relationship between $A\beta$ and apoE depends on $A\beta$'s degree of oligomerization and solubility as well as the apoE isoform that is expressed. Therefore, depending on the isoform expressed, the upregulation of apoE may not be neuroprotective but instead contribute to $A\beta$ damaging effects within astrocytes and between astrocytes and neurons.

CHAPTER 5

A β ₁₋₄₂ REGULATES APOE THROUGH cAMP

Introduction

The treatment of hippocampal astrocytes with dibutyryl-cAMP, a cell-permeable cAMP analog, has been shown to increase apoE expression and protein secretion levels (Figures 1.A and B) (Cedazo-Mínguez et al., 2001a).

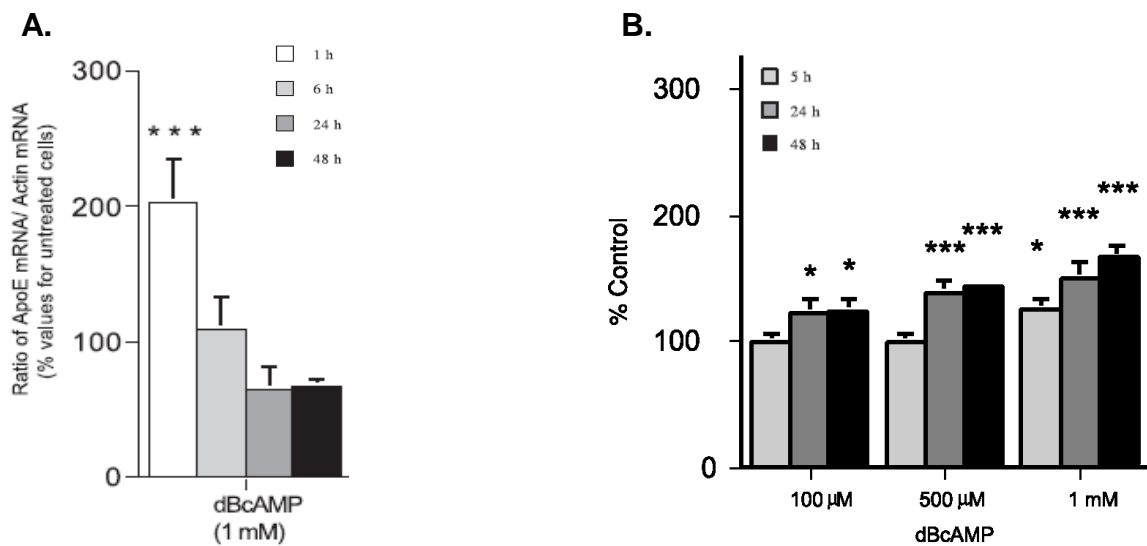

Figure 1. Effects of dBcAMP on apoE expression and secretion in primary rat astrocytes. **A. ApoE expression levels.** ApoE mRNA levels were determined after treating the cells with 1 mM dBcAMP for 1, 6, 24 or 48 h. Individual values were normalized by calculating the ratio between apoE and actin mRNA levels in the same cell group. Data are expressed for these ratios as percentages of the ratios for untreated cells at the respective time points. Values are means \pm S.E.M. of 3 experiments performed in triplicate. **B. ApoE secretion levels.** Cells were treated with a range of concentrations (100 μ M - 1 mM) of dBcAMP for 5, 24 or 48 h. Data are expressed as percentage of control secretion at the respective time points as mean \pm S.E.M. values (n=5). Significances were determined using ANOVA followed by Fisher's post-hoc test: * $p \leq 0.05$, *** $p \leq 0.001$ compared to controls (Cedazo-Mínguez, et al 2001a).

In addition to this, several lines of evidence have suggested an association between the neurodegeneration seen in AD and the second messenger cAMP. Observation of both cerebrospinal fluid and cerebral blood vessels of AD patients indicated an increase in cAMP levels (Table 1) (Martínez et al., 1999; Martínez et al.,

2001). Levels of this second messenger appear to be increased after astrocytic activation, which also occurs after A β exposure (LaDu et al., 2001; Prapong, et al., 2001).

	AD	Old controls	Adult controls
Frontal	12 \pm 2.5* [#]	1.8 \pm 0.8	2.0 \pm 1.5
Temporal	15 \pm 2.6* [#]	2.8 \pm 1.1	1.2 \pm 1.1
Parietal	3.2 \pm 0.8	1.4 \pm 1.0	1.2 \pm 1.3
Visual	1.2 \pm 0.4	0.9 \pm 0.9	0.8 \pm 0.5

Table 1. Vessel cAMP immunostaining in AD and control brains. Number of positive vessels per square millimetre of tissue section. Values are given as mean \pm S.D. * $p \leq 0.01$ for statistically significant differences between AD and control patients. [#] $p \leq 0.01$ for statistically significant differences among different regions. Mean age: (AD) = 72.6 \pm 4.6, (OC) = 76.4 \pm 6.8, (AC) = 53.2 \pm 2.3 (Martinez et al., 2001).

Taking all this evidence into account, we proposed the participation of cAMP as a second messenger in the pathway behind the A β -induced increase in apoE mRNA expression and protein levels in astrocytes.

Material and Methods

Cell culture

DITNC1 rat astrocytes were purchased from American Type Culture Collection (Rockville, MD). These cells have been shown to have the phenotypic characteristics of type 1 astrocytes. Astrocyte cells were incubated in Dulbecco's modified Eagle's medium containing 10% fetal bovine serum and 5% glutamate for two days until confluence and maintained at 37°C, 5% CO₂ and 90% relative humidity. The cells at 80-85% confluence were treated with medium containing 1% lipoprotein deficient serum replacing the 10% fetal bovine serum and incubated for 16 h prior to experimentation. All experiments were done using confluent astrocytes. For primary astrocytes refer to Chapter 4.

Amyloid beta

A β ₁₋₄₂, the reverse protein A β ₄₂₋₁ and A β ₁₋₄₀ were purchased from Bachem California Inc and prepared fresh as described on Chapter 4.

Quantification of cAMP levels

Cells were incubated with fresh A β ₁₋₄₂ (1 μ M) for 0, 5, 10, 20, 30, 60, 90 and 120 minutes, after which time the cells were harvested. In some experiments, 1 μ M of the reverse protein A β ₄₂₋₁ and the shorter protein A β ₁₋₄₀ were used to test the specificity of A β ₁₋₄₂ on cAMP levels. Levels of cAMP were determined in astrocytes using an immunoassay kit from Assay Designs. Cells were harvested with trypsin/EDTA, lysed using 0.1M HCl containing 0.1 Triton X-100 and centrifuged at 16000 x g for 4 min. The supernatant was removed and the protein content and cAMP levels determined. Standards and samples were added to a pre-coated microtiter plate coated with goat antibody

specific to rabbit IgG, sodium acetate buffer was added followed by a solution containing alkaline phosphatase conjugated with cAMP and a solution containing rabbit polyclonal antibody to cAMP. The plate was then incubated at room temperature for 2 h on a plate shaker at 500 rpm. Following this incubation, the plate was washed three times with TBS and after the final wash the wells were dried. A solution containing p-nitrophenyl phosphate was added to each well and incubated at room temperature for 1 h without shaking after which time the reaction was terminated using a solution of trisodium phosphate in distilled water. The plate was read immediately at an optical density of 405 nm using a microplate reader (Molecular Devices).

ApoE protein levels

Primary mouse astrocytes were incubated with 1mM of dB-cAMP for 0.5, 1 and 16 hours. Please refer to Chapter 4 for cell lysing protocol. ApoE protein levels were determined by western blot analysis. Samples (200 ug protein of the lysate per well) were electrophoresed on a 10% SDS-Tricine-HCl precast gel (Bio-Rad). The proteins were transferred to a nitrocellulose membrane and incubated with primary monoclonal mouse anti-rat apoE (1:800) from BD Laboratory. Horseradish peroxidase-conjugated goat anti-mouse IgG (1:2000) was used as a secondary antibody (Pierce). Immunoreactivity was visualized with SuperSignal West Pico Chemiluminescent (Pierce). Band density was quantitated by densitometry using an Eagle Eye II video system and EagleSight software (Stratagene).

Data Analysis

Data are based on three to five independent cell culture preparations. Differences between the groups were analyzed using Student's *t* test. Statistical significance was established at a level of $p \leq 0.05$.

Results

A β ₁₋₄₂ increases cAMP levels in primary astrocytes

Figure 2 shows that incubation of mouse primary astrocytes with A β ₁₋₄₂ for 10 min significantly ($p \leq 0.05$) increased cAMP levels while incubation at later time periods did not show any significant effects. There was approximately a two-fold increase in cAMP levels in the A β ₁₋₄₂ treated cells at the 10 min incubation time compared with the control condition. To rule out non-specific effects of A β ₁₋₄₂ on cAMP levels, astrocytes were also incubated with the reverse protein A β ₄₂₋₁ and the shorter protein A β ₁₋₄₀. Both the reverse protein A β ₄₂₋₁ and A β ₁₋₄₀ did not have a significant effect on cAMP levels. Similar effects of A β ₁₋₄₂ on cAMP levels were also observed in DITNC1 astrocytes (data not shown).

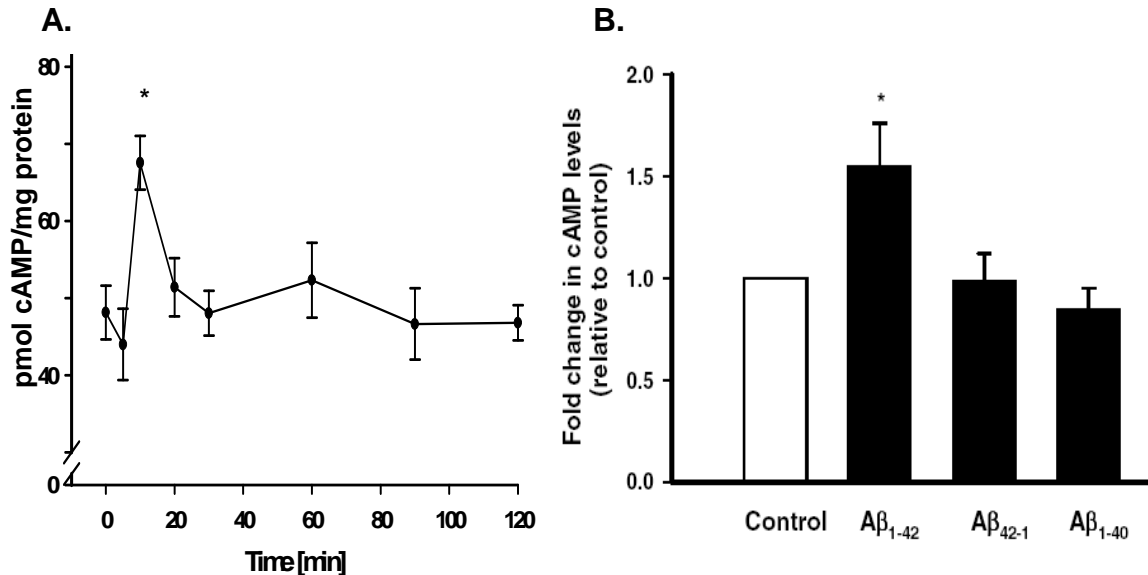

Figure 2. A β ₁₋₄₂ increases cAMP levels in primary astrocytes. **A.** Cells were incubated with A β ₁₋₄₂ for different time periods (5, 10, 15, 20, 30, 60, 90, 120 min) after which cells were harvested as described under Materials and Methods. Levels of cAMP were determined using an enzyme immunoassay kit (Assay Designs) according to the manufacturer's instructions. Values are means \pm S.E. ($n = 3 - 5$), * $p \leq 0.01$ as compared with other time periods. **B.** Astrocytes were incubated with 1 μ M of A β ₁₋₄₂, A β ₄₂₋₁ or A β ₁₋₄₀ as described above and cAMP levels determined after a 10 min incubation. Values are means \pm S.E. of fold change in cAMP levels relative to control ($n = 3$), * $p \leq 0.01$ as compared with control, and other treatment conditions (Igbavboa et al., 2006).

dBcAMP increases apoE protein levels in DITNC1 rat astrocytes

After finding that $A\beta_{1-42}$ increased cAMP levels we determined if exposing astrocytes to cAMP would increase apoE abundance (Figure 3). Treatment with dibutyryl-cAMP, a cAMP analog, significantly ($p \leq 0.001$) increased apoE levels when astrocytes were incubated for 2 h, compared with control, 0.5h and 16h. ApoE levels were also significantly ($p \leq 0.01$) higher than control when incubated with dBcAMP at 0.5 h. No significant effect was seen after 16 h of treatment.

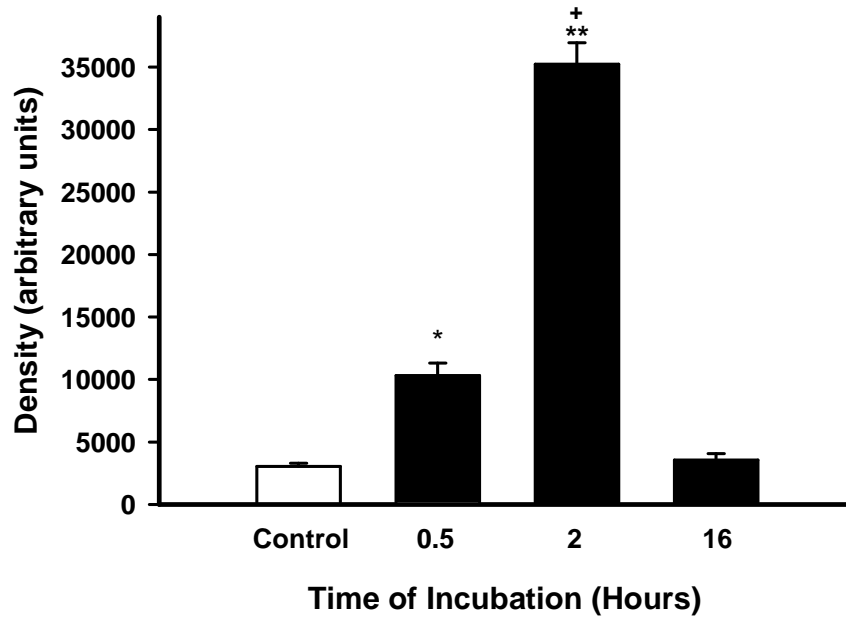

Figure 3. ApoE abundance is increased by dibutyryl-cAMP in DITNC1 astrocytes. Cells were incubated with db-cAMP (1 μ M) that is a cell permeable analogue of cAMP for 0.5h, 2h, and 16 h after which time cells were harvested. Levels of apoE were determined by western blots and quantified by densitometry as described under Material and Methods. Values are means \pm S.E. (n = 3). * $p \leq 0.01$, ** $p \leq 0.001$ as compared with control; + $p \leq 0.001$ as compared with 0.5 h.

Discussion

Multiple components of signal transduction pathways are altered in AD (Martínez et al., 1999; Saitoh et al., 1993). Several lines of evidence have suggested an association between the neurodegeneration seen AD and the second messenger cAMP (Martínez et al., 1999; Martínez et al., 2001; LaDu et al., 2001; Praong, et al., 2001). Cyclic AMP has a wide range of cell type-specific effects on cell growth, cell activation, and differentiation (Zhang et al., 2003). Stimulation of cAMP signaling has been associated with changes in cellular plasticity in the adult and developing CNS (McManus et al., 1999). In astrocytes, cAMP has been shown to induce their differentiation, characterized by morphological changes and decreased proliferation (McManus et al., 1999).

As discussed in Chapter 3, neurodegeneration leads to astrocytic activation (Akiyama et al., 2000). Evidence shows that this activation, as well as A β , leads to increased cAMP levels (LaDu et al., 2001). One group has reported an elevation of cAMP levels in both cerebrospinal fluid and cortical brain vessels from AD subjects when compared to an age-matched control group (Table 1) (Martínez et al., 1999; Martínez et al., 2001). The increased cAMP immunostaining seen in the AD samples was mainly localized in the hippocampus, a region known to be greatly affected by the characteristic amyloid plaques and neurodegeneration seen in AD.

ApoE is primarily synthesized in astrocytes and the purpose behind this chapter's experiments was to determine if the full length protein A β ₁₋₄₂ would increase cAMP levels in mouse primary cortical astrocytes, implicating this molecule in our A β -cAMP-apoE hypothetical pathway. Our results show that the observed increase in cAMP levels in primary astrocytes was specific for A β ₁₋₄₂. The reverse protein A β ₄₂₋₁ and the shorter

protein A β_{1-40} did not significantly alter cAMP levels (Figure 2.B). There was almost a two-fold increase in cAMP levels at an incubation time of 10 min after which time cAMP levels generally returned to control levels (Figure 2.A). An earlier report found that the fragment A β_{25-35} (10 μ M) significantly increased cAMP levels in rat hippocampal neurons with the largest increase at 2 h, versus 48 and 72 h (Praopong et al., 2001). Differences between our data and Praopong's group may be attributable to cell type, incubation time, A β species and concentration.

Furthermore, it has been reported that dibutyryl-cAMP, a cell permeable cAMP analog, increased apoE expression and protein secretion levels in hippocampal astrocytes (Figures 1.A and B) (Cedazo-Mínguez et al., 2001a). Conversely, another study reported that incubation of astrocytes with dBcAMP for 12 h did not alter cell-associated apoE protein levels (LaDu et al., 2000b). As can be seen in Figure 3, an incubation period of 16 h did not alter apoE levels after dBcAMP treatment when compared with the control cells, which could indicate that the effects of cAMP on apoE levels appear to be relatively short-lived and decline over time. Our results show that after treating DINTC1 rat astrocytes with 1mM dBcAMP there is an increase in total apoE protein abundance after 2 hours (Figure 3), time were we have also showed an A β -induced increase in apoE levels (Chapter 4). In conclusion, our findings confirm cAMP involvement as a second messenger in the A β_{1-42} transcriptional activation of apoE in astrocytes.

CHAPTER 6

FRESH A β ₁₋₄₂ ACTS ON β -ADRENERGIC RECEPTORS

Introduction

Stimulation of apoE levels by A β ₁₋₄₂ may be mediated by an increase in cAMP formation but the mechanism behind this increase is not clear. Activation of the cAMP-dependant pathway involves the binding of an extracellular ligand to a G protein-coupled receptor (GPCR) which, through the G-stimulatory (G_s) alpha subunit, activates the membrane-associated enzyme adenylyl cyclase, leading to the generation of cAMP from ATP (Taskén and Aandahl, 2004). Previous reports have shown that A β activates the G_s protein (Molnár et al., 2004; Rymer and Good, 2001; Prapong et al., 2001). Some of the GPCRs that couple to the G_{αs} subunit in the brain include: 5-HT receptors, adenosine receptor, β -adrenergic receptors (β AR) and the dopamine receptors D₁-like family.

Experimental work done on rat cortical cultures has shown that after treating astrocyte-rich cultures (90-95%) with 10 μ M of several compounds capable of activating adenylyl cyclase (norepinephrine, dopamine, serotonin, histamine, chloroadenosine and isoproterenol) only norepinephrine and isoproterenol, a non-selective β AR agonist, produced a detectable increase in cAMP accumulation (Rosenberg and Li, 1995). Additional work done with adenosine confirms that these receptors do not appear to be involved in the cAMP-dependant pathway in astrocytes (Figure 1.B.) (Abe and Saito, 1998). Interestingly, the response curve of the isoproterenol-induced increase in cAMP levels looks very similar to our A β -induced cAMP curve (see Chapter 5, Figure 2). Both curves show a rapid temporary peak response, followed by a fast decline. Other groups

have shown similar results (Figure 1) (Shain et al., 1987; Rosenberg and Li, 1995; Abe and Saito, 1998).

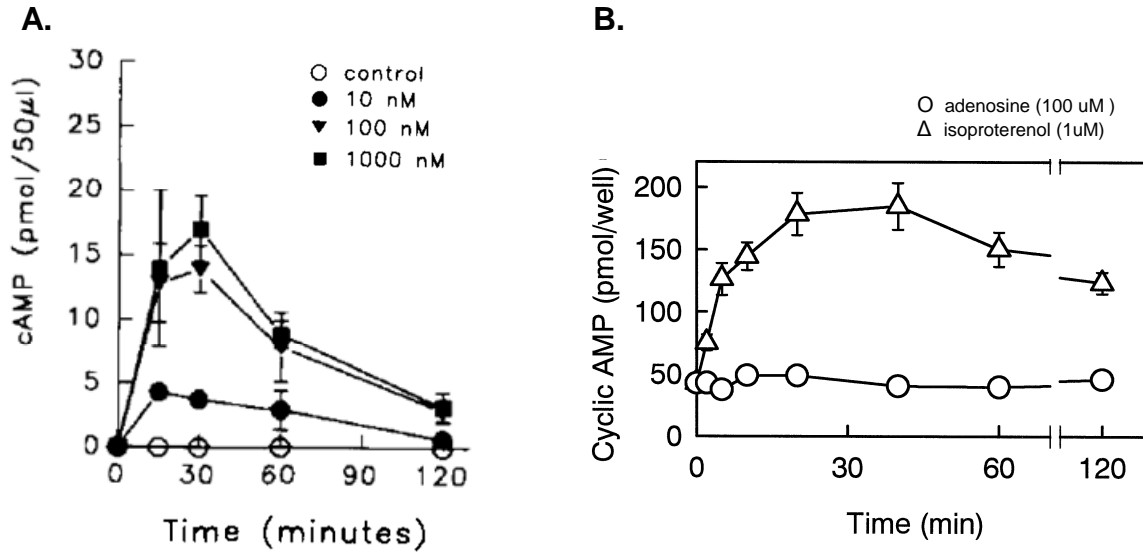

Figure 1. Isoproterenol stimulates intracellular cAMP accumulation. **A.** Astrocyte-rich cultures were exposed to isoproterenol at selected concentrations and times. Medium was collected, cells extracted and samples analyzed by HPLC for cAMP. One representative experiment is shown. Error bars represent standard deviation. Graph shows the time course of intracellular cAMP accumulation, with a peak response at 15 min (Rosenberg and Li, 1995). **B.** Effects of adenosine and isoproterenol on cellular cyclic AMP level in astrocytes. Cells were exposed to 100 µM adenosine (○) or 1 µM of isoproterenol (Δ) for 0, 2, 5, 10, 20, 40, 60 or 120 min. Intracellular cyclic AMP level in each condition was determined by enzyme-immunoassay. Data are means ± S.E.M., $n = 5$ (Abe and Saito, 1998)

It is particularly noteworthy that isoproterenol has also been shown to increase apoE secretion levels in rat astrocytes while arterenol (aka norepinephrine) and serotonin did not have a significant effect (Figure 2) (Cedazo-Mínguez et al, 2001a).

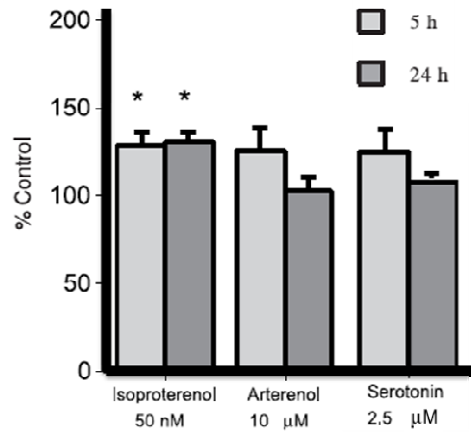

Figure 2. Isoproterenol elevates apoE secretion levels. Rat primary hippocampal cultures were treated for 5 or 24 h with 50 uM isoproterenol, 10 uM arterenol and 2.5 uM of serotonin. Bars show the mean \pm S.E.M. of three experiments with data expressed as percentage of apoE secretion under control conditions. Significances were determined using ANOVA followed by Fisher's post-hoc test : * $p \leq 0.05$, ** $p \leq 0.01$. (Cedazo-Mínguez et al., 2001a).

Another interesting finding about β AR is that their activation, particularly that of the β_2 AR, appears to have neuroprotective effects both *in vitro* and *in vivo*, see Figure 3 (Semkova et al., 1996; Junker et al., 2002; Culmsee et al., 2007). In addition, a recent publication has revealed that clenbuterol enhances the memory performance in aging animals (Ramos et al., 2008).

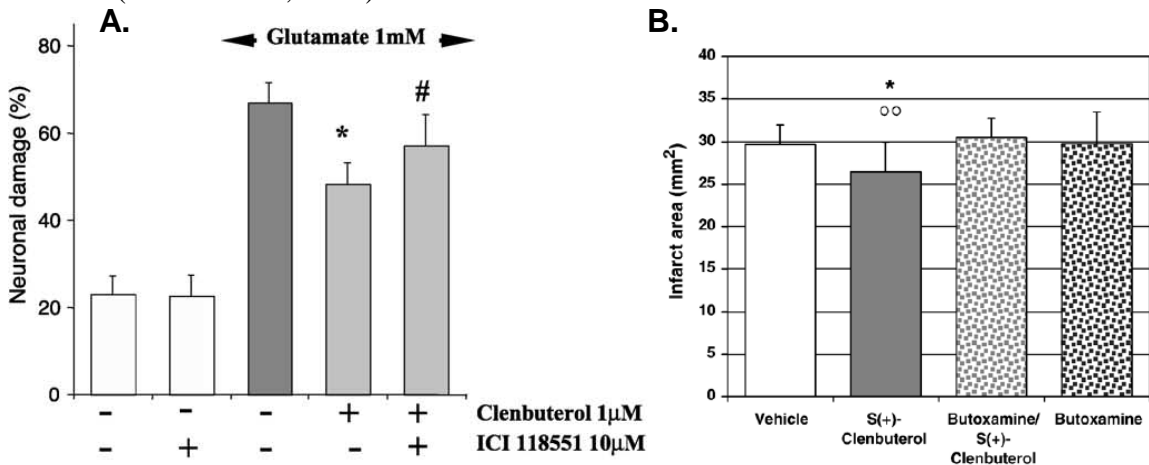

Figure 3. Neuroprotection by clenbuterol is mediated by specific β_2 AR stimulation. **A.** Hippocampal cells were incubated with ICI 118551 (β_2 AR antagonist) 15 min prior clenbuterol (1 uM). Cultures were exposed to clenbuterol 4 h before and up to 18 h after glutamate exposure (30 min, 1 mM). Neuronal damage was determined by Trypan blue exclusion. Values are means \pm S.D. of $n = 5-6$ experiments. * $p \leq 0.05$, compared to glutamate treatment; # $p \leq 0.05$ compared to clenbuterol/glutamate treatment (ANOVA, Scheffe's) (Junker et al., 2002). **B.** Mouse model of permanent focal cerebral ischemia. β_2 AR antagonist butoxamine (5 mg/kg, i.p.) was applied 20 min before S(+)-clenbuterol (0.3 mg/kg) injection. Infarct areas are given as means \pm S.D. of 15 animals. * $p \leq 0.05$ compared to vehicle controls; $\infty p \leq 0.001$ compared to butoxamine-treated groups (Culmsee et al., 2007).

The evidence that β ARs agonists and apoE have neuroprotective effects suggests a potential interaction between β ARs activation and apoE homeostasis. Upon reviewing the expression and function of all the GPCR that could potentially be involved in this pathway in astrocytes, we propose that $A\beta_{1-42}$ stimulates cAMP and apoE levels by initially acting on β AR.

Material and Methods

Chemicals

All chemicals used, unless specifically mentioned, were purchased from Sigma. Concentrations of the β AR agonist and antagonists used were based on earlier studies (Baker et al., 2003; Igbavboa et al., 2006) and preliminary experiments: isoproterenol 20 μ M; propranolol 100 μ M; betaxolol 150 μ M; and ICI 118551 15 μ M. Concentrations for serotonin (2.5 μ M) and arterenol (1 μ M) were based on previous work in astrocytes (Cedazo-Mínguez et al., 2001a).

RNA isolation

Mouse primary astrocytes were incubated with $A\beta_{1-42}$ (1 μ M) and the β AR agonist isoproterenol (20 μ M) for 60 minutes. We had previously reported that maximal $A\beta$ stimulation of apoE mRNA levels in astrocytes occurred after a 60 min incubation period (Chapter 4). $A\beta_{1-42}$ was incubated in the presence or absence of several β AR antagonists; non-selective antagonist propranolol (100 μ M), β_1 selective antagonist betaxolol (150 μ M) and the β_2 selective antagonist ICI 118551 (15 μ M). Antagonists were preincubated with cells for 2 min prior to the addition of $A\beta$. After this treatment, the RNA isolation protocol was followed as described in Chapter 4.

Real time PCR

For real time PCR the iQ SYBR Green Supermix (Bio-Rad) was used. RNA was reverse transcribed using the iScript cDNA Synthesis Kit (Bio-Rad) following the conditions specified by the manufacturer. To set-up the reaction, we followed the manufacturer's recommendations using 150 ng of cDNA, 0.2 μ M for the ApoE primers

and 0.05 uM for GAPDH (reference gene). The sequences for the primer pairs used were: *ApoE* (203 bp) 5'-GAGGAACAGACCCAGCAAATA-3', 5'-GTTGTTGCAGGACAGGAGAAG-3' and *GAPDH* (150 bp) 5'-GACATCAAGAAGGTGGTGAAGCAG-3', 5'-AAGGTGGAAGAATGGGAGTTGC-3'. The primers were designed using the Primer 3 program (<http://frodo.wi.mit.edu/primer3/input.htm>). The cycling conditions were; cycle 1: 3 min at 95°C, cycle 2: 10 s at 95°C, 30 s at 56°C for apoE and 58°C for GAPDH, 1 min at 72°C, all repeat 45 times, cycle 3: 20 s at 55°. The thermal cycler/detection instrument used was the iQ5 (Bio Rad). Data are presented as the mean \pm SE of a group of 3 samples. The apoE mRNA expression ratio was obtained after normalizing the apoE data versus a reference gene (GAPDH). The method used for analyzing the data was the Livak Method ($2^{-\Delta\Delta CT}$).

Quantification of cAMP levels

A β_{1-42} was used in the presence or absence of β_1 AR antagonist betaxolol (150 uM) or β_2 AR antagonist ICI 118551 (15uM) (Lenard et al. 2003; Igbavboa et al., 2006). Mouse primary astrocytes were incubated with A β_{1-42} (1 uM) for 10 min, after which time the cells were harvested. Antagonists were preincubated with cells for 2 min prior to the addition of A β . Please refer to Chapter 5 for determination of cAMP levels.

ApoE protein levels

Mouse primary astrocytes were incubated with A β_{1-42} (1 uM) in the presence or absence of β_1 AR (betaxolol, 150 uM) and β_2 AR (ICI 118551, 15uM) antagonists for 2 h. We had previously reported that maximal A β stimulation of apoE protein levels in

astrocytes occurred after a 2 h incubation period (Igbavboa et al., 2003; Igbavboa et al., 2006). Antagonists were preincubated with cells for 2 min prior to the addition of A β . Cell lysis followed treatment. Refer to Chapter 4 for cell lysing protocol. Refer to Chapter 4 and 5 for apoE western blot protocol.

Data analysis

Experimental data are based on 3 to 5 independent cell culture preparations. Differences between the groups were analyzed using Student's *t* test. Statistical significance was established at a level of $p \leq 0.05$.

Results

Isoproterenol, a non-selective β -adrenergic receptor agonist, increases apoE mRNA expression

We and others have reported that $A\beta_{1-42}$ increases apoE protein levels in astrocytes (LaDu et al., 2000b; Igbavboa et al., 2003). We showed in Chapter 4 that $A\beta_{1-42}$ effects on apoE levels were due to increased mRNA expression levels and that cAMP was involved after observing that its analog dBcAMP could increase apoE levels (Chapter 5). Other groups have also reported that dBcAMP increases apoE mRNA levels in astrocytes (Cedazo-Mínguez et al., 2001a). Here, we intend to determine if activation of the β AR, a known GPCR coupled to the cAMP-dependant pathway, could mimic the effects seen with $A\beta_{1-42}$ treatment, which could potentially indicate its participation in the $A\beta$ -apoE pathway in astrocytes.

It was discussed earlier how isoproterenol, a non-selective β AR agonist, increased apoE secretion levels in astrocytes. Therefore, we decided to take a look at the effects of this agonist on apoE mRNA levels. $A\beta_{1-42}$ had its maximum effect on apoE expression levels after 60 min, consequently this time-point was used for the mRNA experiments. The 60 min treatment with 20 μ M of isoproterenol significantly ($p \leq 0.001$) increased apoE mRNA levels, results that were comparable to those obtained with $A\beta_{1-42}$ (Figure 4).

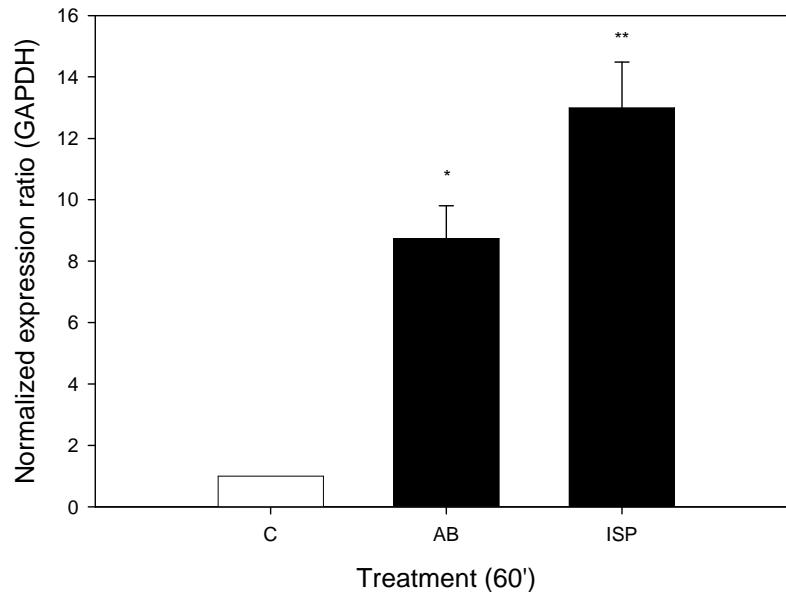

Figure 4. β AR agonist, isoproterenol, increases apoE expression levels. Primary astrocytes were incubated with fresh $A\beta_{1-42}$ (1 μ M) or isoproterenol (ISP, 20 μ M) for 60 minutes. Levels of apoE mRNA were determined by real time PCR and normalized against the house keeping gene GAPDH using the Livak method ($2^{-\Delta\Delta CT}$). n = 3, * $p \leq 0.005$, ** $p \leq 0.001$.

β AR antagonists inhibit $A\beta_{1-42}$ induced stimulation of apoE mRNA in primary astrocytes

The previous experiment showed the potential involvement of the β AR in the $A\beta$ -induced increase of apoE expression levels. To further support our hypothesis and determine $A\beta$ specificity, we examined if the $A\beta_{1-42}$ effect could be inhibited by the non-selective antagonist propranolol and the selective antagonists betaxolol (β_1 AR) and ICI118551 (β_2 AR).

As seen on Figure 5, the $A\beta_{1-42}$ effect on apoE mRNA levels was significantly inhibited by both the non-selective antagonist propranolol ($p \leq 0.01$) and the β_2 AR antagonist ICI118551 ($p \leq 0.005$), with ICI showing a greater inhibitory effect. The β_1 AR

antagonist betaxolol did not show any significant effects, indicating that fresh A β ₁₋₄₂ may act on apoE expression levels preferentially through the β ₂ receptor.

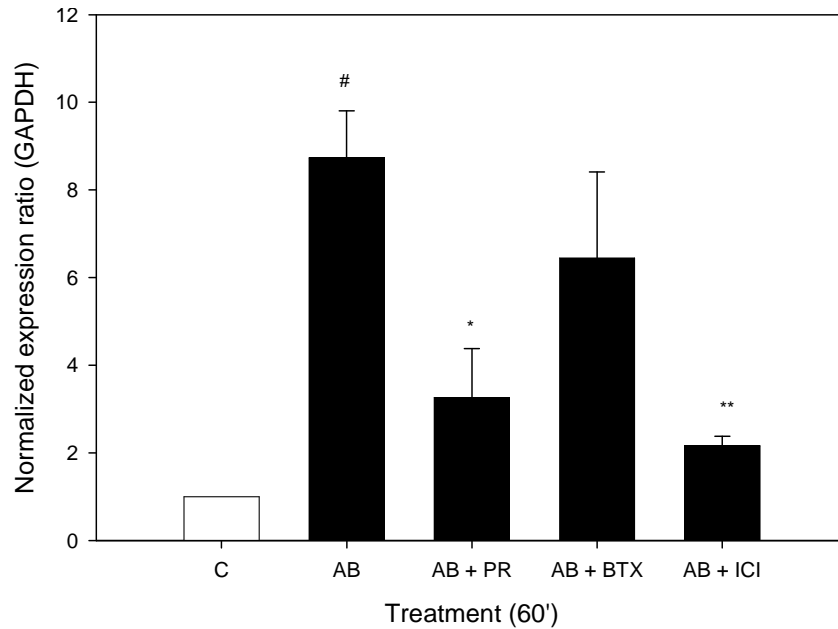

Figure 5. β AR antagonists inhibit A β ₁₋₄₂ stimulatory effects on apoE mRNA levels. Primary astrocytes were incubated with fresh A β ₁₋₄₂ (1uM) and propranolol (PR, 100 uM), betaxolol (BTX, 150 uM) or ICI118551 (ICI, 15 uM) for 60 minutes. Levels of apoE mRNA were determined by real time PCR and normalized against the house keeping gene GAPDH using the Livak method ($2^{-\Delta\Delta CT}$). n = 3, # $p \leq 0.005$ (versus Control group), * $p \leq 0.01$, ** $p \leq 0.005$ (versus A β group).

β AR selective antagonists inhibit A β ₁₋₄₂ induced stimulation of apoE protein levels

After the observation that β AR antagonists could block the stimulatory effects of A β ₁₋₄₂ on apoE mRNA levels, we determined if A β ₁₋₄₂ stimulation of apoE protein levels could also be inhibited by the same selective β AR antagonists. The stimulatory effect of A β ₁₋₄₂ on apoE protein levels was significantly inhibited by the β ₁AR antagonist betaxolol ($p \leq 0.05$) and the β ₂AR antagonist ICI118551 ($p \leq 0.004$). ICI118551 had a greater inhibitory effect (43%) than did the β ₁AR antagonist betaxolol (20%) (Figure 6).

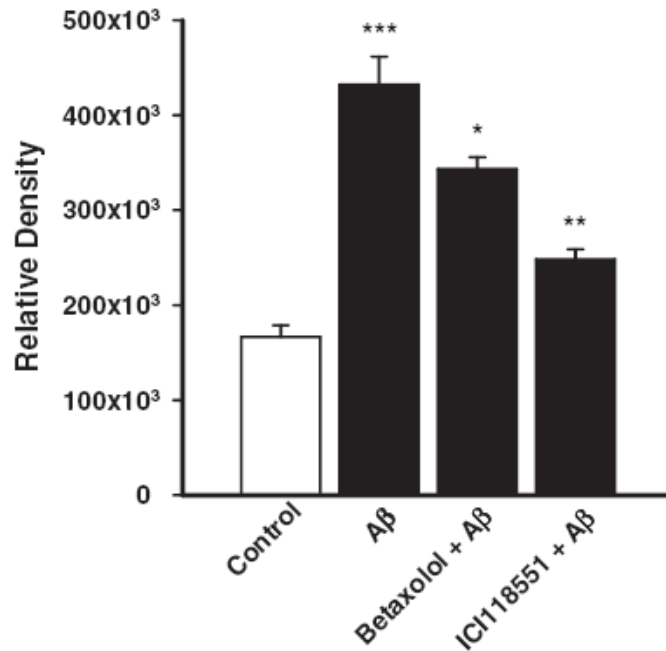

Figure 6. Selective β_1 and β_2 AR antagonists inhibit A β_{1-42} induced stimulation of apoE protein levels. Mouse primary astrocytes were incubated for 2h with either A β_{1-42} alone (1 μ M) or in combination with betaxolol (150 μ M) or the ICI18551 (15 μ M). Data are means \pm S.E. the densitometric scans from western blots representing apoE immunoreactivity ($n = 3$). *** $p \leq 0.001$ as compared to control; ** $p \leq 0.004$ and * $p \leq 0.05$ as compared to a β alone (Igbavboa et al., 2006).

β AR selective antagonists inhibit A β_{1-42} induced stimulation of cAMP

Activation of the β AR is known to elevate cAMP levels. Dibutyryl-cAMP, a cell permeable analog of cAMP increases both apoE expression and secretion levels in astrocytes (Cedazo-Mínguez et al., 2001a). Therefore, to further examine the involvement of the β AR in this pathway, we determined if the A β_{1-42} stimulation of cAMP (Chapter 5, Figure 3) levels could be inhibited by the selective β_1 AR antagonist betaxolol and the selective β_2 AR antagonist ICI18551.

The stimulatory effects of A β_{1-42} on cAMP levels were significantly inhibited by both selective antagonists. However, the two antagonists differed in their ability to inhibit A β_{1-42} stimulation of cAMP levels. The β_2 AR antagonist ICI18551 had a significantly

greater inhibitory effect ($p \leq 0.004$) when compared with the β_1 AR antagonist betaxolol ($p \leq 0.02$) (Figure 7). The β_3 AR antagonist SR59230A did not inhibit the effects of $A\beta_{1-42}$ (data not shown).

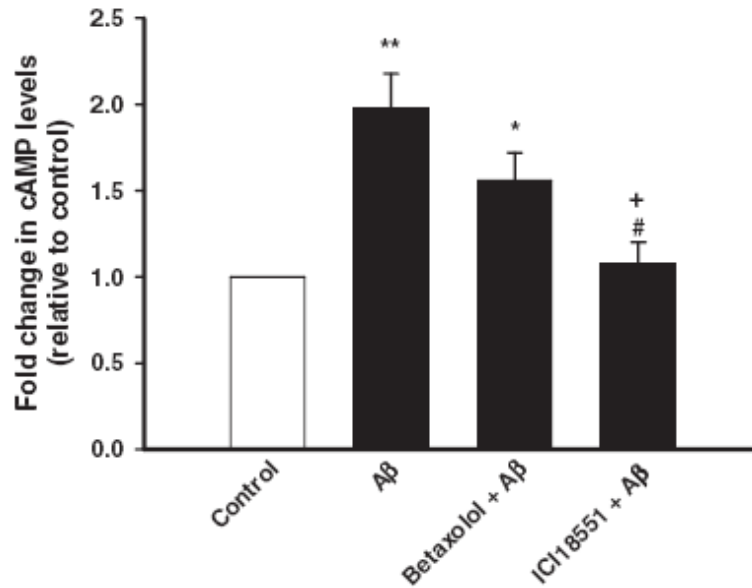

Figure 7. Selective β_1 and β_2 AR antagonists inhibit $A\beta_{1-42}$ induced stimulation of cAMP levels. Mouse primary astrocytes were incubated with $A\beta_{1-42}$ (1 μ M) in the presence and absence of the β_1 AR antagonist betaxolol (150 μ M) or the β_2 AR antagonist ICI18551 (15 μ M) for 10 min, cells were then harvested and cAMP levels determined. Data are means \pm S.E. of the fold change in cAMP levels relative to the control ($n = 3$). ** $p \leq 0.001$ as compared with the control; * $p \leq 0.02$ and + $p \leq 0.004$ as compared with $A\beta$ alone; # $p \leq 0.02$ as compared with the $A\beta$ plus betaxolol (Igbavboa et al., 2006).

Effect of serotonin and arterenol on apoE protein levels in DINTC1 astrocytes

Other groups have shown that after treating astrocyte-rich cultures with compounds capable of activating adenylyl cyclase only norepinephrine and isoproterenol were able to produce a detectable increase in cAMP levels (Rosenberg and Li, 1995). It has been reported that serotonin also increases apoE secretion levels, however, these data appear to be inconclusive in some instances (Cedazo-Mínguez et al., 2001a). We evaluated both arterenol and serotonin in order to determine any apoE protein changes associated to the cAMP-dependant pathway. The concentrations used (2.5 μ M, serotonin

and 1 μ M, arterenol) were based on the work done by this group in which a small increase in apoE secretion was observed after 5 h incubation in rat primary hippocampal astrocytes (Cedazo-Mínguez et al., 2001a). Here, we treated DITNC1 rat astrocytes for 2 h with either arterenol or serotonin. A significant increase in apoE protein levels was seen after arterenol treatment, while no effect was observed after using serotonin (Figure 8). Reports indicate astrocytes express α_1 , β_1 and β_2 ARs and little of the cAMP-responsive serotonin receptor (Hertz et al., 1984; Aoki, 1992; Shao and Sutin, 1992; Duffy and MacVicar, 1995; Mantyh et al., 1995; Morin et al., 1997; Hirst et al., 1998; Porter and McCarthy, 1997; Morin et al., 2000). These results could be attributed to the different levels of receptor expression in astrocytes of cAMP-dependent type and support our hypothesis that A β_{1-42} is acting specifically on the β AR, receptors that appear to be more widely expressed in these cells.

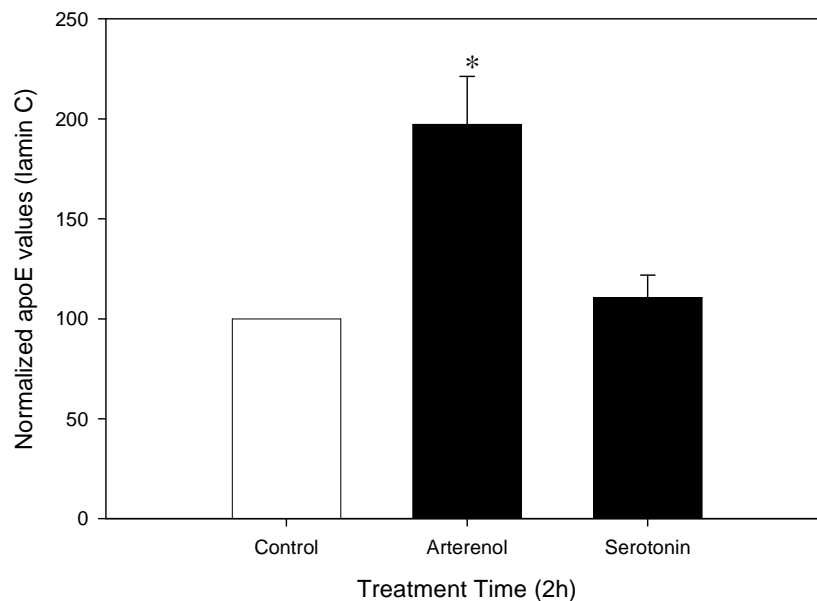

Figure 8. Serotonin and arterenol effects on apoE protein levels. Mouse primary astrocytes were incubated for 2h with either serotonin (2.5 μ M) or arterenol (1 μ M). ApoE protein levels were determined by western blot and quantified by densitometry. Data are means \pm S.E. of the percentage increase from control and normalized to lamin protein levels (apoE:lamin C ratio). n = 3. * $p \leq 0.05$.

Discussion

Our research shows that the stimulation of apoE levels by $A\beta_{1-42}$ appears to be regulated through the activation of the cAMP-dependant pathway (Chapter 5). Earlier studies have shown that of the tested compounds that could activate the cAMP pathway, only isoproterenol, a non-selective β AR agonist, increased both cAMP and apoE secretion levels in astrocytes (Shain et al., 1987; Rosenberg and Li, 1995; Abe and Saito, 1998; Cedazo-Mínguez et al., 2001a). This information leads us to believe that the $A\beta_{1-42}$ - cAMP - apoE pathway could involve the participation of the β AR.

Figure 3 in Chapter 4 shows that $A\beta_{1-42}$ elevates apoE levels by a transcriptional mechanism. Here, we show that isoproterenol has the same effect on apoE message (Figure 4). We took a further look into the involvement of the β AR and the potential specificity of $A\beta_{1-42}$ by using selective β AR antagonists. When evaluating the effects of the antagonists on the $A\beta$ -induced increase in apoE mRNA levels, we noted that these effects were inhibited by both the non-selective β AR antagonist propranolol and the selective β_2 antagonist ICI18551, while the β_1 selective antagonist betaxolol did not significantly block the $A\beta_{1-42}$ effect (Figure 5). These results confirm participation of β AR in the $A\beta$ -induced increase in apoE mRNA levels, particularly that of the β_2 subtype.

As previously discussed, $A\beta_{1-42}$ increases apoE levels, this effect is transcriptional, involves cAMP and could be inhibited by β AR antagonists. We evaluated the affect of these same β_1 and β_2 selective antagonists to test if other $A\beta$ -induced effects could be blocked. Both betaxolol and ICI18551 inhibited the $A\beta_{1-42}$ stimulated increase of both apoE and cAMP levels. However, the two antagonists differed on their ability to

block the A β stimulation, with ICI18551 (β_2) showing a greater inhibitory effect (Figure 6 and 7). In addition to this, we tested the β_3 AR antagonist SR59230A but it did not show any inhibitory effects on the A β_{1-42} induced cAMP levels (data not shown). These findings indicate that A β_{1-42} does not act on β AR uniformly, exerting its effects mainly through β_2 AR.

Astrocytes are the most numerous cell type in the CNS. A considerable amount of evidence has accumulated over the years demonstrating that glial cells *in vitro* express a wide variety of receptors with β ARs being the most extensively studied (Salm and McCarthy, 1989; Mantyh et al., 1995). Several reports indicate that the major portion of the cAMP response to β AR stimulation derives from glial cells (Morin et al., 1997). Even though astrocytes express the α_1 , β_1 and β_2 ARs, research indicates that the predominant adrenergic receptor appears to be of the β_2 type (Hertz et al., 1984; Aoki, 1992; Shao and Sutin, 1992; Duffy and MacVicar, 1995; Mantyh et al., 1995; Morin et al., 1997; Porter and McCarthy, 1997; Morin et al., 2000). In addition, reports have shown that β_2 AR deficient astrocytes have lower basal cAMP levels when compared to wild type cells (Chesik et al., 2008). Taken together, this information suggests that astrocytes and the β_2 AR could be responsible for the bulk of the cAMP response that occurs in brain, agreeing with our findings.

In addition to the β AR agonists, we tested arterenol and serotonin, two drugs that can activate the cAMP-dependent pathway, potentially increasing apoE levels in astrocytes (Figure 8). Serotonin didn't affect apoE levels while arterenol significantly increased apoE abundance, in a similar manner to A β_{1-42} and isoproterenol. Out of the three receptors expressed by astrocytes, only the β_1 and β_2 activate the cAMP dependent

pathway, although arterenol (noradrenaline) can act on both α and β receptors only its effect on the β AR could generate this significant effect on apoE abundance. Because this neurotransmitter has relatively little effect on β_2 receptors, due to relative selectivity, ($\alpha_1 = \alpha_2$; $\beta_1 \gg \beta_2$) it is possibly exerting its effects on apoE through the β_1 receptor (Goldberg, 1977). The antagonist work described on this chapter shows that although A β acts mainly through the β_2 AR, the predominant β AR in astrocytes, it affects the β_1 subtype as well.

Even though it has been reported that serotonin can stimulate cAMP formation in primary astrocytes it did not increase apoE protein levels in our experiment (Figure 8), however, these reported effects have been small and not always consistent (Hertz et al., 1984). Serotonin has 7 classes of receptors with astrocytes only expressing 5 (5-HT₁, 5-HT₂, 5-HT₃, 5-HT₆ and 5-HT₇). Of these receptors, it appears that 5-HT_{2A} and 5-HT₇ are the only functional types. The 5-HT₇ receptor is known to be coupled to adenylate cyclase but this receptor is not the predominant type in astrocytes (Hirst et al., 1998; Porter and McCarthy, 1997). The low receptor abundance might contribute to the small increase in cAMP after the serotonin treatment (Figure 8) (Hertz et al., 1984). It is important to keep in mind that the cAMP-induced effect on apoE levels is dose-dependant (Chapter 5; Cedazo-Mínguez et al., 2001a), therefore, if the activation is only minor the effect on apoE levels might not be evident.

It is of particular interest to mention that β AR and apoE are thought to play important roles in neuroprotection afforded by astrocytes (Rebeck et al., 2002; Junker et al., 2002). Extensive work done on β_2 AR indicates that their activation is the

predominant mechanism underlying the neuroprotective effects of β AR agonists. This suggests β_2 AR agonists may provide a therapeutic target for regulating astrocyte function in both normal and injured CNS (Mantyh et al., 1995). The co-treatment of β_2 AR agonists with other drugs has been considered a useful strategy to enhance the cerebroprotective properties of β_2 AR agonists, while reducing counteractive systemic effects (Junker et al., 2002; Culmsee et al., 2004; Mossello et al., 2008).

In summary, we conclude that the $A\beta$ -induced increase in apoE mRNA and protein levels is primarily associated with β_2 AR-coupled formation of cAMP. These results help not only clarify the relationship between $A\beta_{1-42}$ and apoE but also show how this could affect AD progression and provide a potential mechanism that could help fight this fast growing disease with the use of β_2 AR agonists and combinational therapy

CHAPTER 7

A β ₁₋₄₂ STIMULATES APOE EXPRESSION LEVELS BY ACTIONS OF THE TRANSCRIPTION FACTOR AP-2

Introduction

A β increases apoE levels in astrocytes but the mechanism behind this effect is not clearly understood. Our group's work, discussed in earlier chapters, demonstrated that A β increases apoE protein levels in astrocytes by the upregulation of mRNA. This increase in apoE is mediated in part by activation of the β AR and a cAMP-dependent pathway. A β effects on apoE were inhibited by β AR antagonists, particularly that of the β_2 receptor type. We believe that A β is affecting apoE protein levels transcriptionally through cAMP and that this pathway may involve the transcription factor AP-2. The activator protein 2 (AP-2) is known to be under the control of cAMP (Imagawa et al., 1987; Roesler et al., 1988; Lüscher et al., 1989) and evidence shows it also regulates apoE gene expression in astrocytoma cells (García et al., 1996) (Figure 1).

As mentioned in Chapter 3, apoE is involved in neurodegeneration and regeneration. ApoE expression and protein levels are known to increase after neuronal injury and in AD (Ignatius et al., 1986; Yamada et al., 1995; Zarow and Victoroff, 1998; LaDu et al., 2001; Haasdijk et al., 2002; Seitz et al., 2003; Cedazo-Mínguez, 2007). On Chapter 5 we described how cAMP, which is upregulated in AD and after astrocytic activation, has been shown to increase apoE expression and protein secretion levels following these events (Martínez et al., 1999; Martínez et al., 2001; Ladu et al., 2001; Praong et al., 2001; Cedazo-Mínguez et al., 2001a). In this context, it is noteworthy that the activity of the proximal apoE promoter in astrocytes is upregulated by cAMP (Figure

1.B; García et al., 1996) and that this region of the promoter has several AP-2 consensus sequences (García et al., 1996; Lahiri et al., 2004; Du et al., 2005; Maloney et al., 2007). The role of AP-2 in the cAMP stimulatory effect on apoE has been previously examined by co-transfecting AP-2-deficient HepG2 cells with an apoE promoter construct and a human AP-2 expression construct (Figure 1.C; García et al., 1999). These experiments confirmed AP-2 involvement on apoE gene regulation by showing a significant apoE promoter activation when AP-2 was expressed (García et al., 1999).

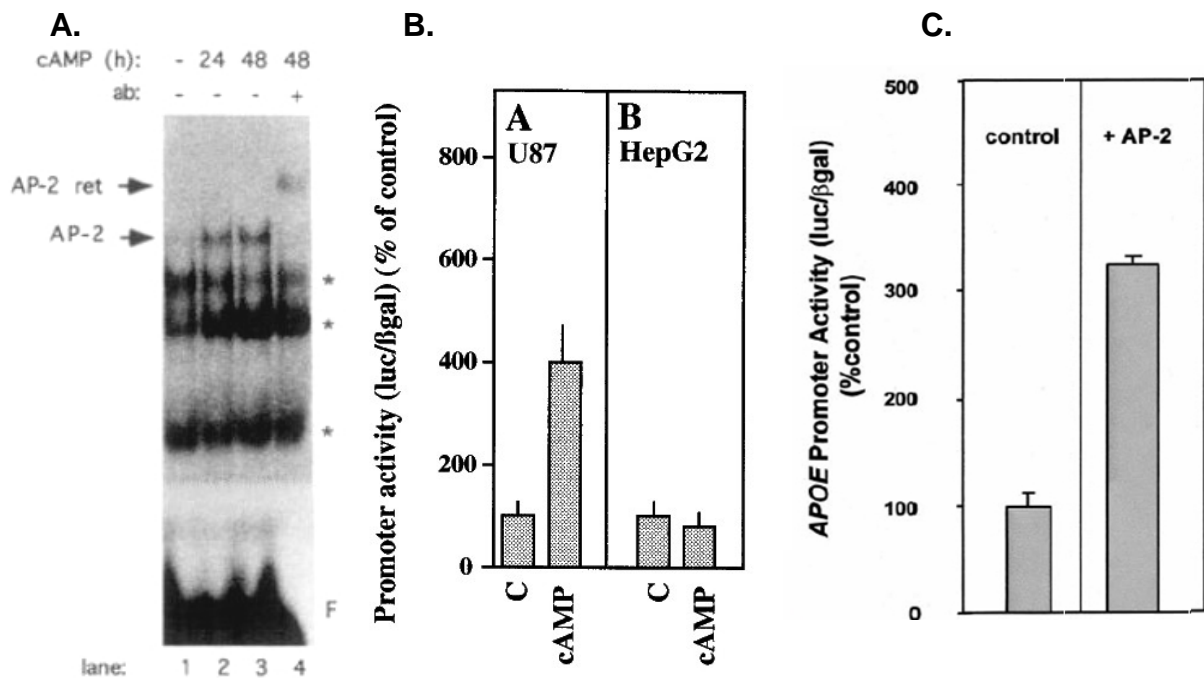

Figure 1. A. Induction of AP-2 in primary astrocytes. Cells were stimulated with 1 μ M dBcAMP for 24 or 48 hr (lanes 2-4) or left untreated (lane 1). Nuclear extracts were isolated and subjected to bandshift analysis using an oligonucleotide containing AP-2 consensus sequence. The AP-2 containing complex was retarded by the anti-AP-2 antibody (lane 4). (Philipp et al., 1994). **B. Effect of cAMP on apoE promoter activity.** U87 (A) or HepG2 (B) cells transiently transfected with a fragment of apoE promoter (construct 4) and a β -galactosidase expression construct and incubated for 48 hr in the absence (C) or the presence of 1 mM dBcAMP (cAMP). Luciferase and β -galactosidase activities were determined and results are expressed as a percentage of activities of untreated control cells (C). Values are the mean \pm SEM of two triplicate determinations (García et al., 1996). **C. Effect of AP-2 on apoE promoter activity.** HepG2 cells were transiently cotransfected with a construction containing the apoE promoter fused to a reporter gene alone (control) or with a expression vector for AP-2. Data are expressed as the mean \pm S.E.M. of three determinations, and are representative of three independent experiments. (García et al., 1999).

AP-2 is an inducible cell type-specific DNA-binding transcription factor family of closely related proteins which have the ability to regulate the expression of specific target genes. This family plays an important role in development, apoptosis, cell-cycle control, and complex morphogenic processes (Moser et al., 1997; Hilger-Eversheim et al., 2000; Wang et al., 2004; Eckert et al., 2005). In the central nervous system, the AP-2 family is one of the critical regulatory factors for neural gene expression and neuronal development (Mitchell et al., 1991; Shimada et al., 1999; Damberg, 2005; Coelho et al., 2005). However, AP-2 transcription factors are not only implicated in normal development, they also seem to be involved in cellular neoplasia, and enhanced AP-2 levels have been reported in various types of cancer (Pellikainen et al., 2007). AP-2 proteins have been described as gatekeepers, controlling the balance between proliferation and differentiation (Damberg, 2005).

	<i>AP-2α</i>	<i>AP-2β</i>	<i>AP-2γ</i>	<i>AP-2δ</i>	<i>AP-2ϵ</i>
<i>H. sapiens</i>	6p24	6p12	20q13.2	6p12.1	1p34.3
<i>P. troglodytes</i>	6p22.3	6p12	21	-	-
<i>M. musculus</i>	13 A5-B1	1 A2-A4	2 H3-H4	1 A3	4 D2.2
<i>R. norvegicus</i>	17p12	9q13	3q42	9q13	5q36
<i>G. gallus</i>	2	3	-	3	-
<i>X. tropicalis</i>	scaffold_278	-	-	-	-
<i>D. rerio</i>	24	20	-	-	-
<i>C. elegans</i>					
<i>D. melanogaster</i>					

Table 1. Chromosomal locations of AP-2 genes: selected species (Eckert et al., 2005).

The AP-2 family, all of approximately 50 kDa, consists of five different isoforms in humans and mice; AP-2 α , AP-2 β , AP-2 γ (also known as AP-2.2), AP-2 δ and AP-2 ϵ (Table 1) (Mitchell et al., 1987; Williams et al., 1988; Moser et al., 1995; Chazaud et al.,

1996; Oulad-Abdelghani et al., 1996; Zhao et al., 2001; Tummala et al., 2003; Feng and Williams, 2003; Wang et al., 2004). Frogs and fish have some of these isoforms and homologs are present in invertebrates (Eckert et al., 2005). The multiple overlapping and diverging expression patterns of AP-2 family proteins suggest that, following the expansion of the family during vertebrate evolution, redundant and non-redundant functions of the individual AP-2 family members evolved (Eckert et al., 2005). The comparison of the amino acid sequences of all five members of the AP-2 gene family indicates high conservation between all five AP-2 family members, particularly within the basic-helix-loop-helix DNA binding and dimerization domain that occupies the C-terminal half of these transcription factors (Figure 2) (Williams and Tjian, 1991; Tummala et al., 2003).

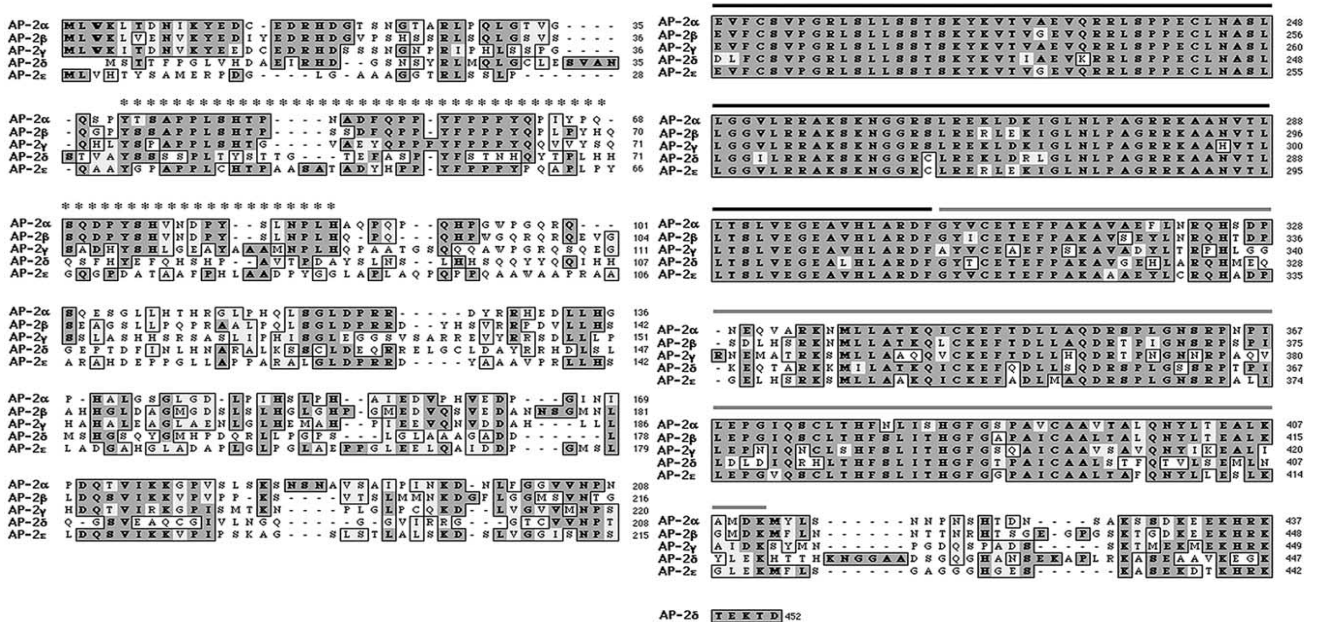

Figure 2. Alignment of AP-2 proteins. Identical amino acid residues are boxed and highlighted dark gray, and conservative changes are shaded light gray. Gaps in the alignment are filled with dashes. The region underneath the line of asterisks (*) shows the conserved activation domain of the AP-2 proteins. The regions underneath the black and gray lines correspond respectively to the DNA contact domain and the dimerization domain of the basic helix-span-helix motif (Feng and Williams, 2003).

A second, less significant, region of homology occurs nearer to the N-terminus of the protein corresponding to the transcriptional activation domain. These comparisons reveal that the α , β , γ and ε genes appear to be more highly conserved in both the transcriptional activation and DNA contact domains than the AP-2 δ gene (Feng and Williams, 2003).

The tissue distribution and developmental functions of AP-2 transcription factors have been studied extensively in several species. In mice, three of the five AP-2 family members (AP-2 α , AP-2 β and AP-2 γ) are co-expressed in neural-crest cells, the peripheral nervous system, facial and limb mesenchyme, various epithelia of the developing embryo and the extraembryonic trophoderm (Chazaud et al., 1996; Moser et al., 1997; Zhao et al., 2001; Zhao et al., 2003). AP-2 δ expression is restricted mainly to the developing heart, CNS and retina (Zhao et al., 2003), whereas AP-2 ε expression is detected in cells of the olfactory bulb and epidermis (Feng and Williams, 2003; Tummala et al., 2003; Wang et al., 2004).

Genes with AP-2 binding sites in their promoter sequences are involved in biological processes such as cell growth and differentiation (Duan and Clemmons, 1995; Gaubatz et al., 1995; Newman et al., 2000; Eckert et al., 2005). The work by the García group points to apoE as an AP-2 regulated gene in brain (Figure 1; García et al., 1996). Their results not only revealed the existence of functional AP-2 binding sites on the apoE promoter region but also provided a potential mechanism for our A β - β AR-cAMP-apoE activation pathway.

We propose that the transcriptional regulation of apoE expression by fresh A β ₁₋₄₂ is dependent on the stimulation of β -ARs and that this pathway involves cAMP and the

transcription factor AP-2. If correct, this finding could be a great contribution towards understanding the regulation of apoE in AD, the complex role of A β in the progression of this disease and help clarify the relationship between these two proteins in Alzheimer's disease.

Material and Methods

Cell culture

Primary astrocytes were obtained from cerebral cortices of new-born C57BL/6 mice as described in Chapter 4. Immortalized DINTC1 rat astrocytes, immortalized HepG2 hepatic cells and immortalized SVGp12 human fetal glial cells were purchased from ATCC (Rockville, MD). DINTC1 and HepG2 cells were grown in DMEM media with 10% FBS and 1% PSN. SVGp12 cells were grown in MEM media with 10% FBS and 1% PSN, 1x G-5 supplement (Invitrogen) was added to the serum-free media. All cells were serum-starved for 24 hr before treatment as indicated, unless noted otherwise.

Cell lysis

After A β treatment cells were rinsed with cold DPBS (Invitrogen) and then a few milliliters of DPBS were added and the cells were scraped. The cell suspension was collected in a pre-chilled 15 mL tube and centrifuged for 3 min at 1500 rpm. The cell pellet was lysed with complete RIPA buffer (Santa Cruz Biotechnology). The solution was gently rocked for 15 min on ice. The lysate was transferred to a 1.5 mL chilled tube and centrifuged at 13000 rpm for 15 minutes. The supernatant was transferred to a new tube and total protein levels measured. Protein levels were quantified by measuring the absorbance of a 1:10 dilution of the lysate at 540 nm using the Bradford Protein Assay from Bio-Rad and BSA (Sigma) as a standard.

Nuclear extraction

Following dBcAMP and A β treatments, extraction of the nuclear fraction was performed using the Nuclear Extraction Kit from Active Motif and the manufacturer's

instructions. Cells were rinsed, collected, and the separation of the cytoplasmic fraction, followed by the lysing of the leftover pellet and the collection of the nuclear fraction. Protein levels were quantified by measuring the absorbance of a 1:5 dilution of the extract at 540 nm following the Bradford Protein Assay from Bio-Rad using BSA (Sigma) as a standard.

AP-2 Western blot

For western blot analysis, 40 ug of protein from the nuclear extract or 80ug from the cell lysate (120ug for AP-2 γ experiment) were electrophoresed on a 10% SDS-Tris-HCl gel (Bio-Rad). The proteins were then transferred to a nitrocellulose membrane (Bio-Rad), blocked and incubated with either a rabbit polyclonal (1:1000) or mouse monoclonal (1:500) antibodies specific for AP-2 α , AP-2 β , or AP-2 γ , all from Santa Cruz Biotechnology. Goat anti-rabbit IgG:HRP conjugate (1:60000, Pierce) or goat anti-mouse IgG:HRP conjugate (1:5000, Transduction Laboratories) were used as secondary antibodies. Immunoreactivity was visualized with SuperSignal West Pico Chemiluminescent (Pierce). Band density was quantitated by densitometry using an Eagle Eye II video system and EagleSight software (Stratagene). Lamin protein levels were used as a loading control; the Lamin A/C rabbit polyclonal antibody (1:200) and the goat anti-rabbit IgG:HRP conjugate antibody (1:6000) were used (Santa Cruz Biotechnologies). For some of the experiments when using AP-2 monoclonal antibodies and lamin antibodies, the SNAP i.d. Protein Detection System (Millipore) was used. In those instances, dilutions used were 5 times more concentrated than the ones described earlier.

For the identification of AP-2 γ , lung and brain tissue homogenates from 3 month old C57BL/6 mice were used. Cerebral cortices and lungs were dissected, cleaned and rinsed with cold DPBS (Invitrogen). The tissue was chopped and transferred to a 1.5 mL chilled tube, the complete RIPA buffer from Santa Cruz was added (1 mL/0.33 g of tissue) and then homogenized making use of a pestle and then vortexed for 1 minute. The lysate was gently rocked for 15 min on ice followed by an additional 1 min vortex. The solution was then centrifuged (13000 rpm for 15 minutes) and the supernatant transferred to a new chilled tube. Protein levels were quantified by measuring the absorbance of a 1:10 dilution of the lysate at 540 nm following the Bradford Protein Assay from Bio-Rad using BSA (Sigma) as a standard.

Electrophoretic mobility shift assay (EMSA)

EMSA was performed using the Promega Gel Shift Assay Core System; this kit included the target nucleotides, HeLa control extract with DNA-binding proteins, binding buffer and reagents for phosphorylation. The AP-2 oligonucleotide sequence used was: 5'-GAT CGA ACT GAC CGC CCG CGG CCC GT-3' (Williams et al., 1988).

The experimental nuclear extracts were desalted using the Zeba Desalt Spin Columns (Pierce) before incubation. The AP-2 oligonucleotides provided by Promega were labeled with ^{32}P and then incubated with either the nuclear extract from primary astrocytes (PA) or from DINTC1 cells (10 ug). Two additional reactions were set up: a negative (without any added protein) and a positive control (using HeLa nuclear extract). The reactions were incubated at room temperature for 10 minutes before 30 ng of the ^{32}P -labeled oligonucleotide was added to each reaction. The mixture was analyzed in 5% acrylamide, 40:1 acrylamide:bisacrylamide gels after an additional 20 min of incubation.

After electroporesis, the gel was covered with plastic wrap and dried on a gel dryer. The gel was exposed to X-ray film for 3.5h at -70°C with intensifying screens and the protein/DNA complexes and free DNA were visualized by autoradiography.

Plasmid construction and DNA isolation

The apoE sequence of the proximal promoter fragment (Figure 3), 5' region between positions -227 and +400 of the apoE gene (construct 4), used by the García group (García et al., 1996), was provided to GeneScript for cloning and subcloning. This fragment was subcloned in front of the luciferase reporter gene of the firefly pGL4.12[luc2CP] vector provided (Promega). The gene product was transferred into bacteria, the company supplied the bacterial stab (bacstab) and colonies of the bacterial culture were grown, one of them isolated and grown on LB medium. The DNA was isolated using the HiSpeed Plasmid Midi Kit (Qiagen) following the manufacturer's instructions. DNA values were quantified by measuring absorbance at 260 nm.

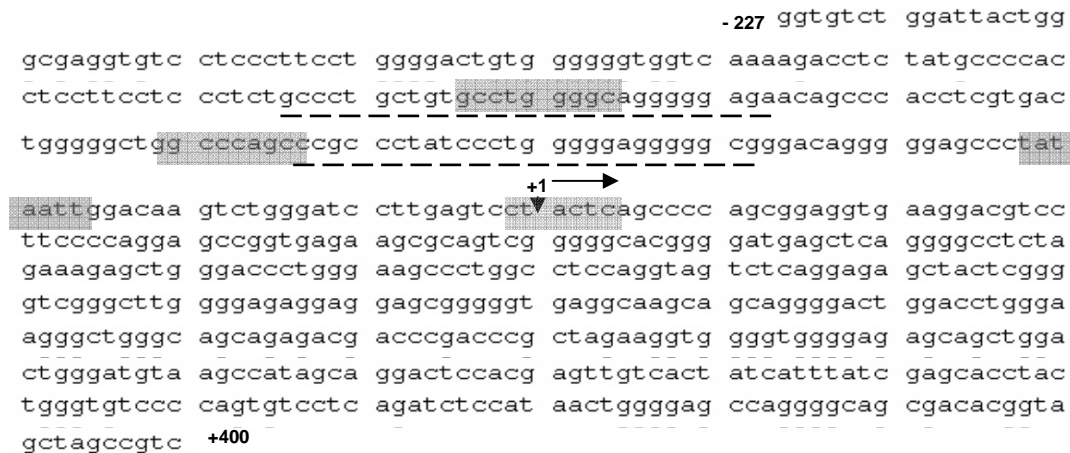

Figure 3. Nucleotide sequence of “construct 4”, upstream region of the human apoE gene. AP-2 binding sites, initiator element (INR) and TATA box are highlighted in sequence. Dotted lines indicate binding sites for recombinant AP-2 in regions from 248 to 274 and from 2107 to 2135 of the apoE promoter as described by García et al. (García et al., 1996). The known AP-2 consensus sequences are 5'- (G/C) CCCA (G/C) (G/C) (G/C) -3' and 5'- GCCN₃GGC- 3'. TATA box, TATA (A/T) A (A/T), is usually located 25-31 bp upstream of the transcription start site. The INR is centered at the transcription initiation site and has a loose consensus sequence; (C/T) (C/T) AN (T/A) (C/T) (C/T). Sequence is numbered relative to the transcription start site +1.

Transfection and gene reporter assay

DINTC1 and HepG2 cells were transfected in 6 well plates with 1 ug of the firefly apoE-*luc* plasmid and 20 ng of *Renilla* pGL4.74[*hRluc*/TK] vector (Promega) using Roche FuGENE HD reagent (transfection ratio was 3:1). Starved cells were treated for 24 hours with A β (1uM) and clenbuterol (15uM). Luciferase assays were performed in triplicate using the Dual-Luciferase Reporter Assay from Promega.

Data analysis

Experimental data are based on three independent cell culture preparations. Differences between groups were analyzed using Student's *t* test. Statistical significance was established at a level of $p \leq 0.05$.

Results

AP-2 isoform expression in primary astrocytes

Reports indicate that of the five AP-2 isoforms, AP-2 α and AP-2 β are the most abundant isoforms in the brain. AP-2 γ is co-expressed with α and β in several brain regions, but studies suggest its expression is the lowest among the three (Moser et al., 1995; Oulad-Abdelghani et al., 1996; Shimada et al., 1999; Coelho et al., 2005; Damberg, 2005). We determined protein levels of these three isoforms in primary astrocytes to find out which could be taking part in apoE gene activation.

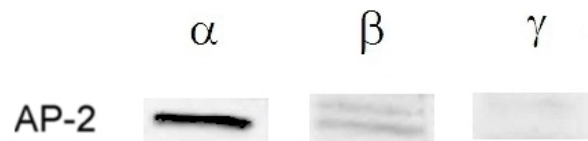

Figure 4. Expression of AP-2 isoforms in primary astrocytes. Protein expression of AP-2 α , β and γ was determined by western blot in cell lysate from mouse primary astrocytes (80 ug, 47-48 kDa).

As seen in Figure 4 the presence of both AP-2 α and β in primary astrocytes is clear, while the expression of AP-2 γ was not detected. To confirm these results, a second western blot (Figure 5) was performed with a different AP-2 γ antibody. The primary astrocytes lysate was compared to that of mouse cerebral cortex and lung. We used a lung homogenate as a positive control based on reports from the Oulad-Abdelghani group which found that AP-2 γ is expressed in this tissue (Oulad-Abdelghani et al., 1996). Our results indicate that the only isoforms that are expressed in mice primary astrocytes are AP-2 α and AP-2 β .

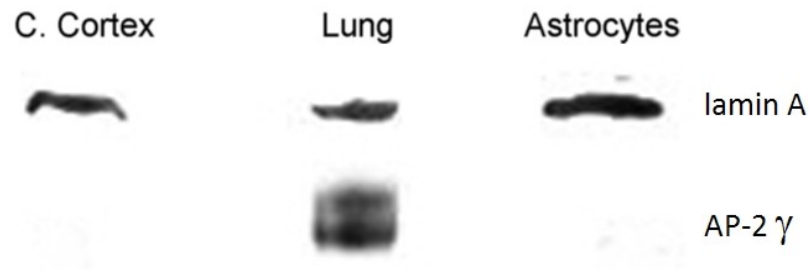

Figure 5. Protein expression of AP-2 γ . The expression of AP-2 γ was tested by western blot in lysates from mice cerebral cortex, lung and primary astrocytes, 120 ug of protein were used.

dBcAMP effects on nuclear AP-2 levels in SVGp12 astrocytes

Several studies have reported that cAMP regulates transcription factor AP-2 (Imagawa et al., 1987; Lüscher et al., 1989; Philipp et al., 1994; LiCalsi et al., 2000; Damberg, 2005). Due to the variability in the treatment conditions and the cell culture used in those studies, we decided to confirm the results following our own conditions (1mM of dBcAMP for 10 minutes in astrocytes). AP-2 is predominantly localized in the nucleus (Eckert et al., 2005), therefore we looked at the effects of dBcAMP on nuclear levels of both AP-2 α and β isoforms expressed in astrocytes. SVGp12 astrocytes (SV40 transformed human fetal glial cells) were used in these experiments.

Our results not only confirm what has been reported on AP-2 modulation by cAMP, but also reveal that cAMP affects both AP-2 isoforms (α and β) in the same manner, although, it appears AP-2 β translocation to the nucleus is greater than the one seen with α (Figure 6).

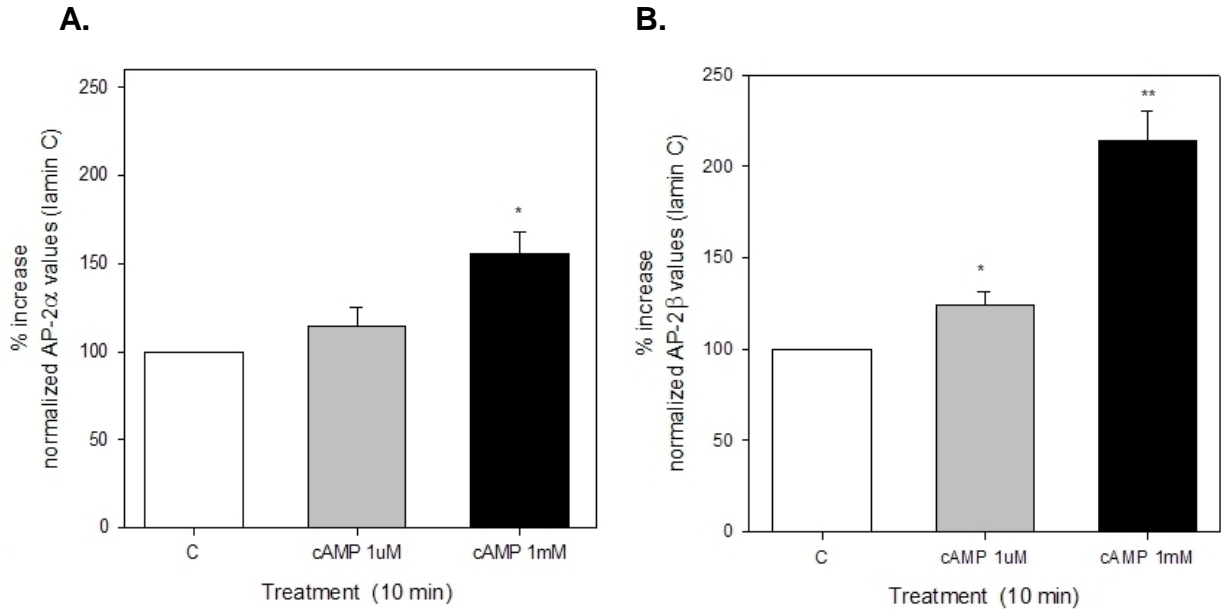

Figure 6. dBcAMP effects on nuclear AP-2 levels. Protein expression levels of AP-2 α (A) & AP-2 β (B) were determined by western blot in nuclear extracts from SVGp12 astrocytes after 10 min treatment with either 1 μ M or 1mM of dBcAMP (40 μ g of protein). Data are means \pm S.E. of the densitometric scans from western blots representing AP-2 immunoreactivity (n = 3). * $p \leq 0.05$, ** $p \leq 0.001$.

A β_{1-42} effects on AP-2 levels in primary astrocytes

Data in Chapter 5 (Figure 2) showed that A β elevates cAMP levels after 10 minutes of treatment. Following our observation that cAMP increases both AP-2 α and AP-2 β levels in the nucleus after the same time period (this chapter, Figure 6), we decided to take a look at the effects of A β on these isoforms levels. We evaluated the effects of A β on the isoforms in both the cell lysate and nuclear extract of primary astrocytes in order to establish if the change in AP-2 α and AP-2 β levels was associated with an increase in total protein levels or a change in distribution of the proteins.

The results show that after A β treatment, the total protein levels (whole cell lysate) of AP-2 α and β were not significantly changed (Figure 7). On the other hand,

levels of both of proteins in the nuclear extract were significantly different, with AP-2 α showing a marked decrease and AP-2 β a significant increase (Figure 8).

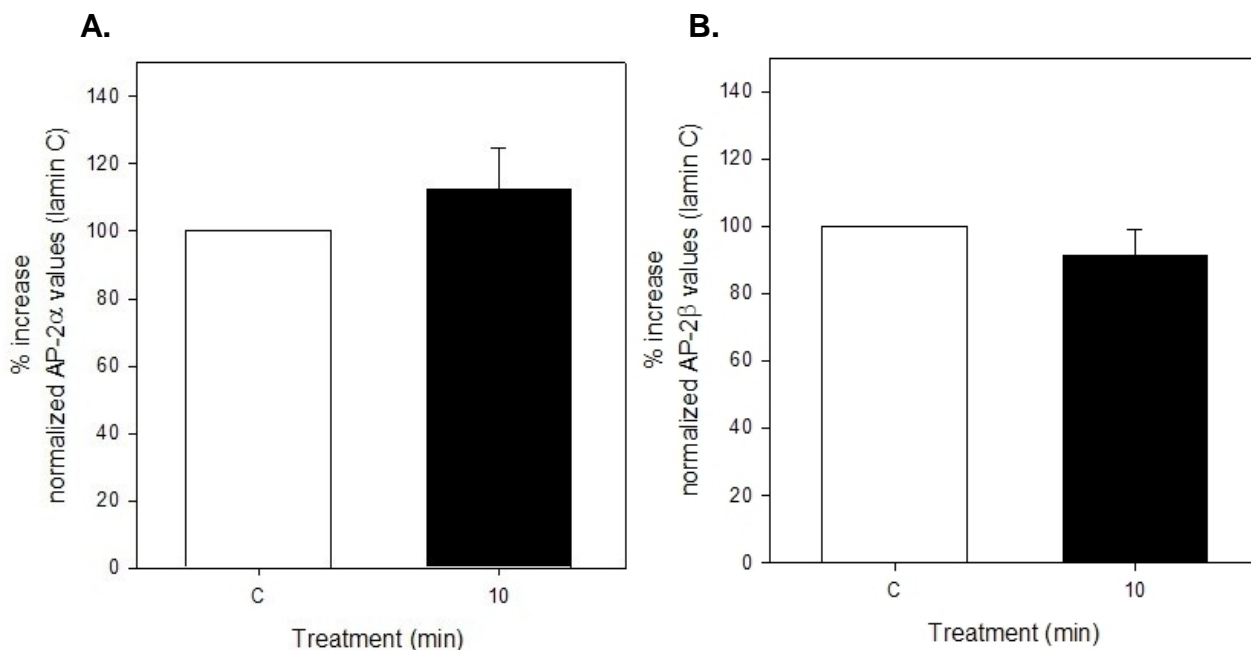

Figure 7. A β ₁₋₄₂ effects on total AP-2 levels in primary astrocytes. Primary astrocytes were incubated with fresh A β ₁₋₄₂ (1 μ M) for 10 minutes. AP-2 α (A) & AP-2 β (B) protein levels were determined from the cell lysate (80 μ g) by western blot. Data are means \pm S.E. of the densitometric scans from western blots representing AP-2 immunoreactivity (n = 3).

An interpretation of these findings is that A β does not affect AP-2 transcriptionally but post-translationally, through changes in intracellular isoform distribution. The differential effects of A β on distribution of the two isoforms suggest that it is acting on another pathway, in addition to the cAMP-dependant pathway. It is important to keep in mind that AP-2 can be affected by both the DAG-PKC, and the cAMP-PKA pathways (Roesler et al., 1988; Moser et al., 1995; Damberg, 2005). Reports indicate that A β could act on PKC by affecting its translocation and activation (Kim et al., 2004; Cedazo-Mínguez et al., 2001b; Balleza-Tapia and Peña, 2009). The activation of both the PKA and PKC pathways by A β could help explain the difference observed in

the nuclear AP-2 isoforms levels obtained after treating the astrocytes with cAMP and A β . These results could indicate that AP-2 β is the isoform responsible for the activation of the apoE promoter region after A β treatment in astrocytes.

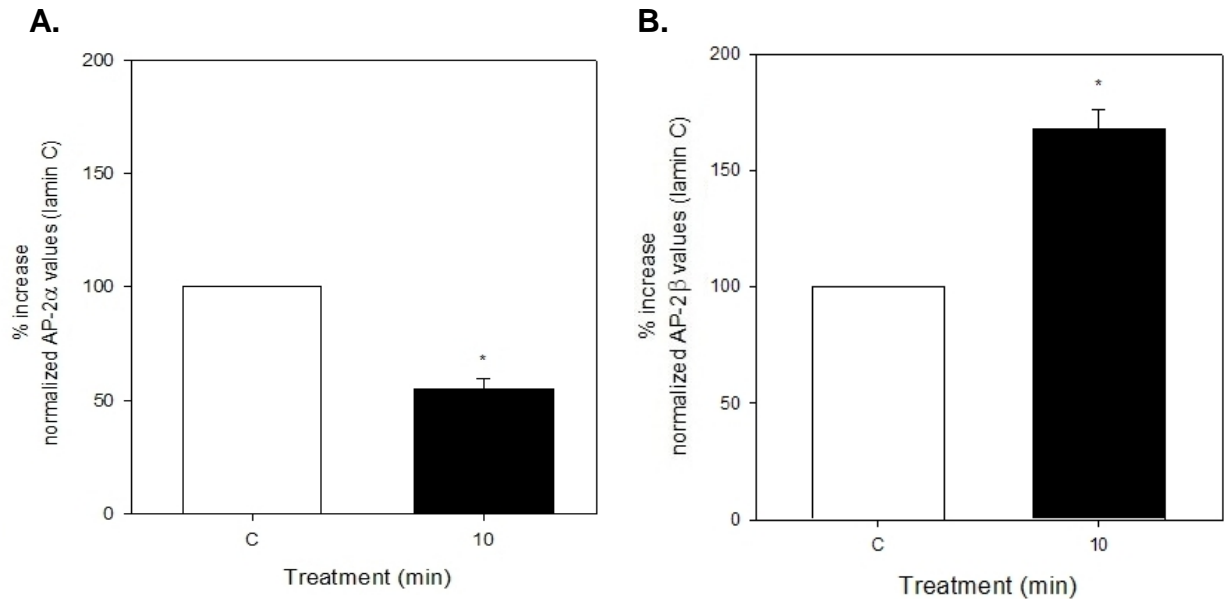

Figure 8. A β ₁₋₄₂ effects on nuclear AP-2 levels in primary astrocytes. Primary astrocytes were incubated with fresh A β ₁₋₄₂ (1 μ M) for 10 minutes. Nuclear AP-2 α (A) & AP-2 β (B) protein levels (40 μ g) were determined by western blot. Data are means \pm S.E. of the densitometric scans from western blots representing AP-2 immunoreactivity (n = 6). * $p \leq 0.00001$

AP-2 DNA binding

The palindromic sequence 5'-GCCN₃GGC-3' is considered a consensus AP-2 binding site for all AP-2 proteins (Imagawa et al., 1987; Williams et al., 1988; Roesler et al., 1988; Bosher et al., 1996, Damberg, 2005). Here, we investigated if the AP-2 present in the nuclear fraction after A β treatment, of both mouse primary astrocytes (PA) and DITNC1 immortalized rat astrocytes, was able to bind to a commercially available radiolabeled oligonucleotide containing the AP-2 DNA-binding consensus sequence mentioned earlier.

As observed in Figure 9 the AP-2 present in the nucleus, before and after A β treatment, binds to the known AP-2 consensus sequence. The reason behind seeing no change before and after the treatment is probably due to the change in the isoforms cell distribution (Figure 8), as both isoforms are expected to bind to this sequence. It is important to note that García's work mainly focused on AP-2 α (Campillos et al., 2003), this experiment confirms the presence of nuclear AP-2 after A β treatment and potentially verifies the ability of the β isoform to bind to the DNA after the A β challenge.

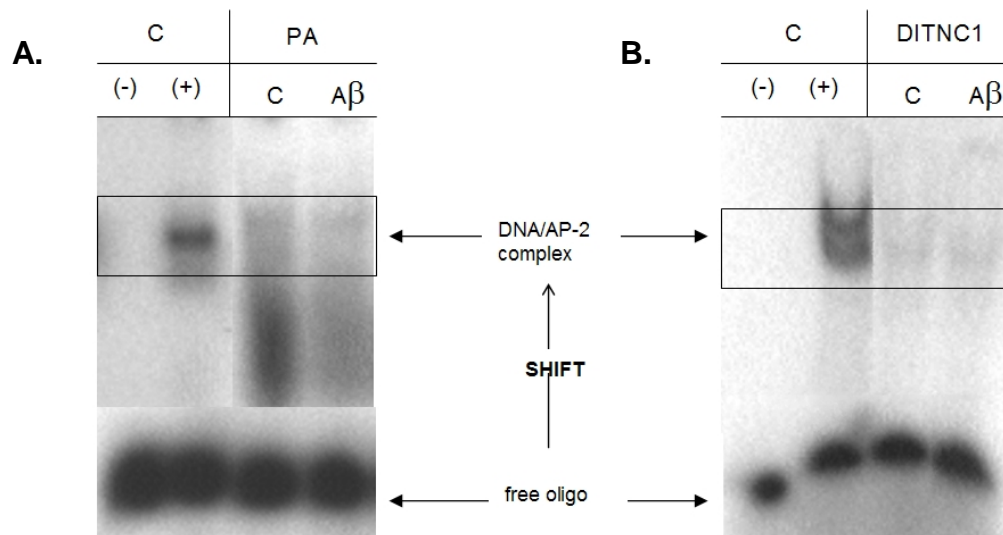

Figure 9. AP-2 DNA-binding after A β treatment. Cells were incubated with and without A β_{1-42} (1 μ M) for 10 minutes. Nuclear extracts (10 μ g of protein) of primary astrocytes (PA, **A**) and DITNC1 (**B**), were subjected to bandshift analysis using a radiolabeled oligonucleotide containing AP-2 consensus sequence. HeLa extract (2.5 μ g of protein, Promega) was used as a positive control (C+), while no protein was added in the negative control (C-).

AP-2 mediates A β -induced apoE promoter function

Previous reports have found that the proximal apoE promoter activity in astrocytes is upregulated by cAMP and that this is mediated by the interaction of AP-2 with two sites located in this gene's proximal region (García et al., 1996). These

experiments were also performed in HepG2, which were used as a negative control since they are known to be AP-2 deficient cells (Imagawa et al., 1987; García et al., 1996).

To understand if the stimulatory effect of A β and the cAMP-dependant pathway is mediated by AP-2, we studied A β and a β_2 agonist (clenbuterol) effect by comparing the luciferase activity of DINTC1 (immortalized rat astrocytes) and HepG2 cells (AP-2 deficient immortalized hepatic cells), both of which were transfected with an apoE promoter fragment that includes the AP-2 binding sites described by the García group (García et al., 1996). The luciferase activity of the DINTC1 was significantly increased with both clenbuterol and A β , while the AP-2 deficient cells (HepG2) did not show any effects (Figure 10). These data supports our hypothesis that A β stimulates apoE promoter function by inducing AP-2.

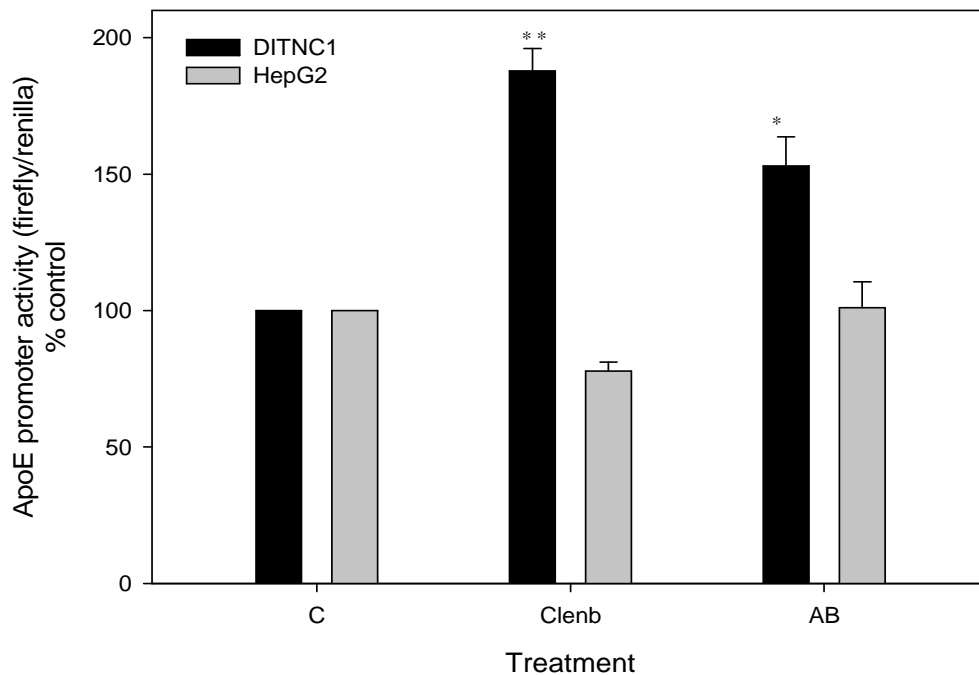

Figure 10. ApoE promoter activity. DINTC1 and HepG2 cells were transfected with a fragment of apoE promoter with functional AP-2 binding sites and a *Renilla* vector, then incubated for 24 hr in the absence or the presence of A β (1 μ M) or clenbuterol (15 μ M). Dual luciferase activities were determined and results expressed as a percentage increase of untreated control cells after normalization with the *Renilla* values. Values are the mean \pm SE (n=3), * $p \leq 0.01$, ** $p \leq 0.001$.

Discussion

Our data show that apoE mRNA and protein levels are increased after A β treatment in astrocytes and these effects are mediated in part by the activation of the β AR and a cAMP-dependent pathway. Genes that are induced transcriptionally by cAMP have been categorized into three general groups; the first, which accounts for the majority of cAMP-responsive genes, consists of genes with CREs (cAMP-responsive elements) that closely fit the consensus DNA-binding sequence of the CRE binding protein (CREB): 5'-TGACGTCA-3'; the second group of genes are those that are induced acutely by cAMP but lack a consensus binding sequence of the CREB type and are characterized by the presence of the AP-2 consensus binding site: 5'-CCCCAGGC-3'; the third group includes those few elements that have no obvious sequence similarity to either of these sites, yet appear to confer cAMP sensitivity (Roesler et al., 1988; Lushner et al., 1989; Walton and Rehfuss, 1990; Park and Kim, 1993; Gao et al., 1997). Work done with astrocytoma cells has revealed the involvement of transcription factor AP-2 in apoE gene expression (García et al., 1996) and that work provided the rationale for looking at the role of this particular transcription factor on the A β -cAMP-apoE activation pathway.

AP-2 (AP-2 α) was first discovered in the late 1980s (Mitchell et al 1987, Williams et al., 1988) with the second isoform, AP-2 β , not characterized until 1995 (Moser et al. 1995). Since then, 3 more isoforms have been found: AP-2 δ , γ and ϵ (Oulad-Abdelghani et al., 1996; Zhao et al., 2001; Wang et al., 2004). Most of the early work done on AP-2, like the one by the García group on apoE and AP-2, focused on the α isoform, since none of the other isoforms had been identified (García et al., 1996; Campillos et al, 2003). Here, we show that there is more than one isoform present in

astrocytes and that both respond in a similar manner to cAMP (Figure 6). A novel finding was the dissimilar response of these isoforms when exposed to A β (Figure 8). Our hypothesis states that A β acts on the β AR leading to an increase in cAMP which in turn acts on AP-2 and the activation of the apoE gene and subsequent increase in its protein levels. The results seen with the two AP-2 isoforms suggest that A β is acting on an additional pathway, other than the cAMP-dependant pathway, and that this could be affecting the AP-2 isoforms differently. While most transcription factors appear to be coupled to a single transduction system, AP-2 seems to be unique in its ability to respond to two distinct second messengers. The transcriptional activation mediated by AP-2 can be induced by two different signal transduction pathways; the phorbol-ester and diacylglycerol-activated protein kinase C, and the cAMP-dependent protein kinase A (Imagawa et al., 1987; Roesler et al., 1988; Moser et al., 1995; Damberg, 2005). Signal transduction pathways via PKA and PKC play important roles in neuronal and non-neuronal systems. Both pathways may be connected by cross-talk in which protein kinase A and C could work together or counteract each other (Nishizuka, 1986; Rozengurt, 1986; Imagawa et al., 1987; Otte et al., 1989; de Groot and Sassone-Corsi, 1992; Wöltje et al., 2000). Many signal transduction systems are altered in AD, one that has been associated with amyloid plaques is the PKC pathway (Saitoh et al., 1993; Roßner et al., 2001). It has been reported that A β could act on PKC by affecting its translocation and activation (Kim et al., 2004; Cedazo-Mínguez et al., 2001b; Balleza-Tapia and Peña, 2009). The modulation of the PKC pathway can affect AP-2 nuclear levels (Rao et al., 2005). Therefore, activation of both the cAMP-PKA and inhibition of the DAG-PKC

pathways by A β could help explain the difference observed in the nuclear AP-2 isoforms levels obtained after treating the astrocytes with cAMP and A β .

AP-2 activity can be controlled at multiple levels: their transactivation potential, DNA binding, subcellular localization and their degradation (Mazina et al., 2001; Nyormoi et al., 2001; Aqeilan et al., 2004; Eckert et al., 2005; Li et al., 2006; Pellikainen et al., 2007). Some of these mechanisms include post-translational modifications, such as protein kinase-mediated phosphorylation, sumoylation and redox regulation, as well as physical interaction with various proteins (Park and Kim, 1993; Huang et al., 1998; García et al., 1999; Eckert et al., 2005). Our results show that both cAMP and A β affect AP-2 intracellular distribution. AP-2 translocation to the nucleus after cAMP and A β treatments occurs as early as 10 minutes, time where we have also reported a peak in cAMP levels after A β treatment (see Chapter 5, Figure 3). Dynamic intracellular localization of proteins is recognized as an important cellular mechanism for the regulation of their activity. An example is the cytoplasmic sequestration of transcription factors NF κ B and NFAT, which stop transcriptional activation until an incoming signal results in nuclear relocalization. Evidence suggests that, like NF κ B and NFAT, AP-2 transcriptional activity is regulated in part by changes in its distribution between nucleus and cytoplasm (Mazina et al., 2001) and our findings with astrocytes are consistent with that conclusion.

AP-2 is primarily located inside the nucleus and its downregulation could be achieved by relocalization to the cytoplasmic compartment (Mazina et al., 2001; Eckert et al., 2005). This seems to be a reversible process, thus when the cell receives the appropriate signal, probably phosphorylation, AP-2 can rapidly return to the nucleus and

resume transcriptional activity (Mazina et al., 2001). Our data indicate that after astrocytes are treated with A β , AP-2 α is translocated to the cytoplasm while AP-2 β nuclear levels increase, suggesting that the isoform involved in the activation of apoE by in astrocytes is AP-2 β .

A β is a complex and dynamic molecule that affects multiple pathways and several transcription factors leading to a series of cellular responses (Balleza-Tapia and Peña, 2009). Our results confirm AP-2 involvement in the A β -apoE activation pathway, and points to AP-2 β as the main isoform involved in astrocytes. These findings not only shed light on the action of this early form of A β , but also on apoE activation pathway in astrocytes, both of which could be very important findings in the understanding of AD pathophysiology.

GENERAL CONCLUSIONS

The average age of the world's population is increasing at an unprecedented rate and within 10 years the elderly will outnumber the children under age 5 for the first time in human history (Kinsella and He, 2009). According to this U.S. Census Bureau report, the number of people 65 and older reached about 506 million as of midyear 2008 and will double to 1.3 billion by 2040, accounting for 14 percent of the total global population. This increase is primarily the result of high fertility levels after World War II and secondarily, but increasingly, the result of reduced death rates at older ages (Kinsella and He, 2009).

With the continuous increase in the number of aged individuals and life expectancy, chronic diseases, in particular AD, have seen a significant rise in prevalence. It is estimated that between the years 2000 and 2050 there will be an approximate 3-fold increase in the number of AD cases (Brookmeyer et al., 2007; Eckman and Eckman, 2007). AD is the 7th leading cause of death in the United States for all ages and 5th in adults over the age of 65, claiming more than 70 thousand lives per year (Kung et al., 2008; Alzheimer's Association, 2008). Even though it is obvious how important and how rapidly this disease is escalating, there is currently no cure for AD. The use of different drugs for AD treatment has only had marginal impact on slowing its progression or improving symptoms such as memory impairment (Shah et al., 2008; van Marum, 2008; Aluise et al., 2008).

Two types of AD have been described; early onset or familial AD and sporadic or late onset AD. This project focuses on the latter type of AD, which is responsible for

more than 90% of the cases and occurs primarily in the aging population (Poirier, 2005). The causes of late-onset AD are not completely identified, but is thought to result from a combination of genetic and environmental factors. Two key players in the development of AD are A β and apoE, evidence suggests an association between both but the linkage is not well understood (Sparks et al., 1990; Fagan and Holtzman, 2000; Ladu et al., 2000b; Ladu et al., 2001; Kimura et al., 2004; Carter, 2005; Poirier, 2005). It appears that this relationship depends on A β 's degree of oligomerization and solubility as well as the apoE isoform that is expressed (Carter, 2005). A β_{1-42} has been shown to be the most neurotoxic and more prone to oligomerize of the A β forms (Suzuki et al., 1994; Klein et al., 2004).

Early work done by our group showed that fresh A β_{1-42} (monomeric-dimeric soluble form), but not the aggregated form (aged), increases apoE protein levels in immortalized astrocytes (Chapter 4) (Igbavboa et al., 2003). This soluble form of A β is one of the earliest species of A β to be deposited and thus is considered to be an early marker of AD (Tabaton and Piccini, 2005; Watson et al., 2005; Georganopoulou et al., 2005). We believe that studying this early form of A β and its effects in astrocytes, the most abundant cells in the CNS and the primary source of apoE, would help to explain the initiation of the cascade of events seen in AD development.

Our group, as well as others, has shown that A β increases apoE protein levels (Ladu et al., 2000b; Ladu et al., 2001, Igbavboa et al., 2003; Kimura et al., 2004; Igbavboa et al., 2006). However, we were the first to show that fresh A β_{1-42} was acting at a transcriptional level, elevating apoE messenger levels (Chapter 4). In order to elucidate the mechanism behind the A β -induced apoE upregulation, we studied the effects of cAMP (Chapter 5). It has been shown that treating astrocytes with cAMP results in the

elevation of apoE expression and secretion levels (Cedazo-Mínguez et al., 2001a). Moreover, several lines of evidence indicate that this second messenger is associated with AD; astrocytic activation and A β lead to an increase cAMP levels and AD patient brain tissue showed increased cAMP immunostaining (Martínez et al., 2001; LaDu et al., 2001). Our work revealed that fresh A β_{1-42} increases cAMP levels in primary astrocytes. We also observed an increase in apoE abundance following dBcAMP treatment, a cAMP analog, which not only supported earlier findings but also confirmed cAMP participation in the A β -apoE pathway (Chapter 5).

The next step was to determine if A β effects were receptor-mediated. It is well known that elevation of cAMP levels is associated with activation of β -adrenergic receptors (β AR) and it has been reported that isoproterenol treatment, a β AR non-selective agonist, increases apoE secretion in astrocytes (Chapter 6) (Cedazo-Mínguez et al., 2001a). Therefore, we decided to take a look at how both β AR agonists and antagonists could affect our proposed pathway. We show that isoproterenol affected apoE at a transcriptional level, upregulating apoE messenger levels in a similar manner to A β . In subsequent experiments β AR participation was confirmed using antagonists, which significantly inhibited A β stimulatory effects on cAMP, apoE protein and mRNA levels (Chapter 6). These antagonistic effects were significantly higher with the use of β_2 antagonists.

Even though astrocytes express the α_1 , β_1 and β_2 ARs, research indicates that the predominant adrenergic receptor appears to be of the β_2 type (Hertz et al., 1984; Aoki, 1992; Shao et al., 1992; Duffy and MacVicar, 1995; Mantyh et al., 1995; Morin et al., 1997; Porter and McCarthy, 1997; Morin et al., 2000). In addition, reports have shown

that β_2 AR deficient astrocytes have lower basal cAMP levels when compared to wild type cells (Chesik et al., 2008). Taken together, this information suggests that astrocytes and the β_2 AR could be responsible for the bulk of the cAMP response that occurs in brain, agreeing with our findings.

In order to further understand the mechanism behind the A β upregulation of apoE, we proposed the participation of transcription factor AP-2 (Chapter 7). The activator protein 2 (AP-2) is known to be under the control of cAMP and evidence shows it also regulates apoE gene expression in astrocytoma cells (Imagawa et al., 1987; García et al., 1996). We discovered that out of the five characterized AP-2 isoforms only two, α and β , are expressed in astrocytes. Our experiments show both of these isoforms responding to cAMP stimulation in a similar manner, by increasing its nuclear abundance. However, when these isoforms were challenged with A β , AP-2 α showed a marked and significant decrease in the nucleus while AP-2 β showed a significant increase in this cell compartment. Total protein levels of both of the isoforms were not changed in astrocytes after A β treatment, indicating that A β was affecting AP-2 cell distribution. The difference between the isoforms levels in the nuclear fraction after A β and cAMP treatments suggests that A β is acting on an additional pathway, other than the cAMP-dependant pathway, which could be differentially affecting the AP-2 isoforms.

AP-2 can be induced by two different signal transduction pathways; the phorbol-ester and diacylglycerol-activated protein kinase C, and the cAMP-dependent protein kinase A pathway (Imagawa et al., 1987; Roesler et al., 1988; Moser et al., 1995; Damberg, 2005). It has been reported that A β can modulate the PKC pathway, therefore

if both the PKA and PKC pathways are being affected it could result in both AP-2 isoforms behaving differently (Imagawa et al., 1987; Balleza-Tapia and Peña, 2009).

We confirmed AP-2 involvement in apoE gene activation with a reporter gene experiment. Only the cells that expressed AP-2 activated the promoter region from the apoE gene after A β and the β_2 selective agonist clenbuterol (Chapter 7). Our data indicate that after astrocytes are treated with A β , the AP-2 β isoform is the only one translocated to the nucleus. These findings support our hypothesis and identify AP-2 β as the isoform responsible for the activation of the apoE gene by A β in astrocytes. Based on the preponderance of our data, we can conclude that the A β -induced increase in apoE mRNA and protein levels is primarily associated with β_2 AR-coupled formation of cAMP and stimulation of AP-2 β . It can not be concluded from this work if fresh A β_{1-42} is acting on the β AR directly or indirectly. It has been suggested that A β activates astrocytes which could in turn lead to the release of cytokines or other signaling molecules that could be affecting the β AR directly.

It is of particular interest to mention that β AR and apoE are thought to play important roles in neuroprotection afforded by astrocytes (Rebeck et al., 2002; Junker et al., 2002). The β_2 AR is upregulated after brain injury or trauma, an event that occurs primarily in activated astrocytes (Shao and Sutin, 1992; Mantyh et al., 1995, Hodges-Savola et al., 1996; Junker et al., 2002). This reinforces the notion that the stimulation of β_2 AR is most likely the predominant mechanism underlying the neuroprotective effects of β AR agonists. These data altogether suggest that β_2 AR agonists may provide a therapeutic target for regulating astrocyte function in both normal and injured CNS

(Mantyh et al., 1995; Semkova et al., 1996; Junker et al., 2002; Culmsee et al., 2007; Ramos et al., 2008). However, combination therapies could be more beneficial, reducing the risk for adverse effects and extending the therapeutic window. Co-treatment with β_2 AR agonists and β_1 AR antagonists could be one useful strategy to enhance the cerebroprotective properties of β_2 AR agonists in vivo by reducing counteractive systemic effects (Junker et al., 2002). Other groups have also suggested a β_2 AR combination therapy; the co-treatment of the β_2 AR agonist clenbuterol and the NMDA antagonist memantine (drug approved for AD treatment, review on Chapter 1) resulted in synergetic neuroprotective effects, evidenced by a reduction of brain damage in an ischemic stroke mouse model (Culmsee et al., 2004). Another potential combinational therapy for the treatment of AD could be the use of selective serotonin reuptake inhibitors (SSRI), first-line agents for the treatment of depression associated with AD, and β_2 AR agonist. Some reports indicate that SSRI reduced the cognitive decline in AD, linking the serotonergic system to cognitive function in AD (Mossello et al., 2008). Serotonin and isoproterenol have been shown to have a synergistic effect on astrocyte apoE secretion, making this an interesting potential therapy. A likely problem and challenge with this latter treatment is that chronic treatment with antidepressants is known to desensitize and/or downregulate the density of β AR (Sulser et al., 1978). However, this common biochemical effect occurs with many but not all antidepressant drugs, some clinically effective selective SSRI, like citalopram, do not downregulate β AR (Holoubek et al., 2004).

It is important to keep in mind that the relationship between A β and apoE depends on A β 's degree of oligomerization and solubility as well as the apoE isoform that is expressed. Depending on the isoform expressed, the upregulation of apoE may not be

neuroprotective but instead contribute to A β -induced perturbation of cholesterol trafficking both within astrocytes and between astrocytes and neurons. The neuroprotective effects of the β_2 AR agonists could also be affected by these factors.

Governments and international organizations are stressing the need for cost-of-illness studies on age-related diseases, in part to anticipate the likely burden of increasingly prevalent and expensive chronic conditions, of which Alzheimer's disease may be the most costly (Kinsella and He, 2009). The number of individuals with AD will continue to increase unless new discoveries facilitate the prevention of this disease. Delaying the onset by five years could reduce the number of individuals with AD by approximately 50% (Brookmeyer et al., 2007). Discoveries like the present findings help not only clarify the relationship between A β_{1-42} and apoE but also show how this could affect AD progression and possibly provide a mechanism that could help fight this fast growing disease with the use of β_2 AR agonists and combinational therapy.

REFERENCES

- Abe K, Saito H. Adenosine stimulates stellation of cultured rat cortical astrocytes. *Brain Res.* 1998;804(1):63-71.
- Akiyama H, Arai T, Kondo H, Tanno E, Haga C, Ikeda K. Cell mediators of inflammation in the Alzheimer disease brain. *Alzheimer Dis Assoc Disord.* 2000;14 Suppl 1:S47-53.
- Aleshkov S, Abraham CR, Zannis VI. Interaction of nascent ApoE2, ApoE3, and ApoE4 isoforms expressed in mammalian cells with amyloid peptide beta (1-40). Relevance to Alzheimer's disease. *Biochemistry.* 1997;36(34):10571-80.
- Aluise CD, Sowell RA, Butterfield DA. Peptides and proteins in plasma and cerebrospinal fluid as biomarkers for the prediction, diagnosis, and monitoring of therapeutic efficacy of Alzheimer's disease. *Biochim Biophys Acta.* 2008;1782(10):549-58.
- Alzheimer's Association, Alzheimer's Disease Facts and Figures. *Alzheimer's & Dementia*, 2008; 4(2).
- Aoki C. Beta-adrenergic receptors: astrocytic localization in the adult visual cortex and their relation to catecholamine axon terminals as revealed by electron microscopic immunocytochemistry. *J Neurosci.* 1992;12(3):781-92.
- Aono, M et al. Apolipoprotein E protects against NMDA excitotoxicity. *Neurobiology of Disease*, 2002; 11: 214–220.
- Aqeilan RI, Palamarchuk A, Weigel RJ, Herrero JJ, Pekarsky Y, Croce CM. Physical and functional interactions between the Wwox tumor suppressor protein and the AP-2gamma transcription factor. *Cancer Res.* 2004;64(22):8256-61
- Baker JG, Hall IP, Hill SJ. Agonist and inverse agonist actions of beta-blockers at the human beta 2-adrenoceptor provide evidence for agonist-directed signaling. *Mol Pharmacol.* 2003;64(6):1357-69.
- Balleza-Tapia H and Peña F. Pharmacology of the intracellular pathways activated by amyloid Beta protein. *Mini Rev Med Chem.* 2009;9(6):724-40.
- Bartus, RT, Dean III RL, Beer B, Lippa AS. The cholinergic hypothesis of geriatric memory dysfunction. *Science* 1982; 217, 408–414.

- Bertram L, Tanzi RE. Thirty years of Alzheimer's disease genetics: the implications of systematic meta-analyses. *Nat Rev Neurosci.* 2008;9(10):768-78.
- Bosher JM, Totty NF, Hsuan JJ, Williams T, Hurst HC. A family of AP-2 proteins regulates c-erbB-2 expression in mammary carcinoma. *Oncogene.* 1996;13(8):1701-7.
- Boyles JK, Pitas RE, Wilson E, et al. Apolipoprotein E associated with astrocytic glia of the central nervous system and with nonmyelinating glia of the peripheral nervous system. *J Clin Invest* 1985;76:1501–1513.
- Brendza RP, Bales KR, Paul SM, Holtzman DM. Role of apoE/Abeta interactions in Alzheimer's disease: insights from transgenic mouse models. *Mol Psychiatry.* 2002;7(2):132-5.
- Brookmeyer R, Johnson E, Ziegler-Graham K, Arrighi HM. Forecasting The Global Burden Of Alzheimer's Disease. Johns Hopkins University, Dept. of Biostatistics Working Papers. 2007;130.
- Campillos M, García MA, Valdivieso F, Vázquez J. Transcriptional activation by AP-2alpha is modulated by the oncogene DEK. *Nucleic Acids Res.* 2003;31(5):1571-5.
- Cedazo-Mínguez A, Hamker U, Meske V, Veh RW, Hellweg R, Jacobi C, Albert F, Cowburn RF, Ohm TG. Regulation of apolipoprotein E secretion in rat primary hippocampal astrocyte cultures. *Neuroscience.* 2001a;105(3):651-61.
- Cedazo-Mínguez A, Wiehager B, Winblad B, Hüttinger M, Cowburn RF. Effects of apolipoprotein E (apoE) isoforms, beta-amyloid (Abeta) and apoE/Abeta complexes on protein kinase C-alpha (PKC-alpha) translocation and amyloid precursor protein (APP) processing in human SH-SY5Y neuroblastoma cells and fibroblasts. *Neurochem Int.* 2001b;38(7):615-25.
- Cedazo-Mínguez A. Apolipoprotein E and Alzheimer's disease: molecular mechanisms and therapeutic opportunities. *J Cell Mol Med.* 2007;11(6):1227-38.
- Chazaud C, Oulad-Abdelghani M, Bouillet P, Décimo D, Chambon P, Dollé P. AP-2.2, a novel gene related to AP-2, is expressed in the forebrain, limbs and face during mouse embryogenesis. *Mech Dev.* 1996;54(1):83-94.
- Checler F. Processing of the beta-amyloid precursor protein and its regulation in Alzheimer's disease. *J Neurochem.* 1995; 65(4):1431-44.
- Checler F and Vincent B. Alzheimer's and prion diseases: distinct pathologies, common proteolytic denominators. *Trends Neurosci.* 2002; 25(12):616-20.

- Chesik D, Wilczak N, De Keyser J. IGF-1 regulates cAMP levels in astrocytes through a beta2-adrenergic receptor-dependant mechanism. *Int J Med Sci.* 2008;5(5):240-3.
- Citron M, Oltersdorf T, Haass C, McConlogue L, Hung AY, Seubert P, Vigo-Pelfrey C, Lieberburg I, Selkoe DJ. Mutation of the beta-amyloid precursor protein in familial Alzheimer's disease increases beta-protein production. *Nature.* 1992; 360(6405):672-4.
- Coelho DJ, Sims DJ, Ruegg PJ, Minn I, Muench AR, Mitchell PJ. Cell type-specific and sexually dimorphic expression of transcription factor AP-2 in the adult mouse brain. *Neuroscience.* 2005;134(3):907-19.
- Culmsee C, Junker V, Kremers W, Thal S, Plesnila N, Krieglstein J. Combination therapy in ischemic stroke: synergistic neuroprotective effects of memantine and clenbuterol. *Stroke.* 2004;35(5):1197-202.
- Culmsee C, Junker V, Thal S, Kremers W, Maier S, Schneider HJ, Plesnila N, Krieglstein J. Enantio-selective effects of clenbuterol in cultured neurons and astrocytes, and in a mouse model of cerebral ischemia. *Eur J Pharmacol.* 2007;575(1-3):57-65.
- Damberg M. Transcription factor AP-2 and monoaminergic functions in the central nervous system. *J Neural Transm.* 2005;112(10):1281-96.
- Danbolt NC. Glutamate uptake. *Prog Neurobiol* 2001; 65: 1–105.
- de Groot RP, Sassone-Corsi P. Activation of Jun/AP-1 by protein kinase A. *Oncogene.* 1992;7(11):2281-6.
- De Keyser J, Mostert JP, Koch MW. Dysfunctional astrocytes as key players in the pathogenesis of central nervous system disorders *Journal of the Neurological Sciences* 2008; 267:3–16.
- Deane R, Sagare A, Hamm K, Parisi M, Lane S, Finn MB, Holtzman DM, Zlokovic BV. ApoE isoform-specific disruption of amyloid beta peptide clearance from mouse brain. *J Clin Invest.* 2008;118(12):4002-13.
- Dodart JC, Marr RA, Koistinaho M, Gregersen BM, Malkani S, Verma IM, Paul SM. Gene delivery of human apolipoprotein E alters brain Abeta burden in a mouse model of Alzheimer's disease. *Proc Natl Acad Sci U S A.* 2005;102(4):1211-6.
- Dolev I, Michaelson DM. A nontransgenic mouse model shows inducible amyloid-beta (Abeta) peptide deposition and elucidates the role of apolipoprotein E in the amyloid cascade. *Proc Natl Acad Sci U S A.* 2004;101(38):13909-14.

- Du Y, Chen X, Wei X, Bales KR, Berg DT, Paul SM, Farlow MR, Maloney B, Ge YW, Lahiri DK. NF-(kappa)B mediates amyloid beta peptide-stimulated activity of the human apolipoprotein E gene promoter in human astroglial cells. *Brain Res Mol Brain Res*. 2005;136(1-2):177-88.
- Duan C and Clemmons DR. Transcription factor AP-2 regulates human insulin-like growth factor binding protein-5 gene expression. *J Biol Chem*. 1995;270(42):24844-51.
- Duffy S and MacVicar BA. Adrenergic calcium signaling in astrocyte networks within the hippocampal slice. *J Neurosci*. 1995;15(8):5535-50.
- Eckert D, Buhl S, Weber S, Jäger R, Schorle H. The AP-2 family of transcription factors. *Genome Biol*. 2005;6(13):246.
- Eckman CB and Eckman EA. An update on the amyloid hypothesis. *Neurol Clin*. 2007;25(3):669-82.
- Eichner JE, Dunn ST, Perveen G, Thompson DM, Stewart KE, Stroehla BC. Apolipoprotein E polymorphism and cardiovascular disease: a HuGE review. *Am J Epidemiol*. 2002;155(6):487-95.
- Elshourbagy NA, Liao WS, Mahley RW, Taylor JM. Apolipoprotein E mRNA is abundant in the brain and adrenals, as well as in the liver, and is present in other peripheral tissues of rats and marmosets. *Proc Natl Acad Sci U S A*. 1985;82(1):203-7.
- Escartin C, Bonvento G. Targeted activation of astrocytes: a potential neuroprotective strategy. *Mol Neurobiol*. 2008;38(3):231-41.
- Evans RM, S Hui, Perkins A, DK Lahiri, J. Poirier and M.R. Farlow. Cholesterol and APOE genotype interact to influence Alzheimer disease progression. *Neurology* 2004;62:1869–1871.
- Fagan AM and DM Holtzman. Astrocyte Lipoproteins, Effects Of Apoe On Neuronal Function, And Role Of Apoe In Amyloid-B Deposition In Vivo. *Microscopy Research And Technique*. 2000; 50:297–304.
- Fagan AM, Watson M, Parsadanian M, Bales KR, Paul SM, Holtzman DM. Human and murine ApoE markedly alters A beta metabolism before and after plaque formation in a mouse model of Alzheimer's disease. *Neurobiol Dis*. 2002;9(3):305-18.

- Farfara D, Lifshitz V, Frenkel D. Neuroprotective and neurotoxic properties of glial cells in the pathogenesis of Alzheimer's disease. *J. Cell. Mol. Med.* 2008; 12(3):762-780.
- Farina C, Aloisi F, Meinl E. Astrocytes are active players in cerebral innate immunity. *Trends Immunol* 2007;28:138–45.
- Fazekas F, Enzinger C, Ropele S, Schmidt H, Schmidt R, Strasser-Fuchs S. The impact of our genes: consequences of the apolipoprotein E polymorphism in Alzheimer disease and multiple sclerosis. *J Neurol Sci.* 2006;245(1-2):35-9.
- Feng W, Williams T. Cloning and characterization of the mouse AP-2 epsilon gene: a novel family member expressed in the developing olfactory bulb. *Mol Cell Neurosci.* 2003;24(2):460-75.
- Francis PT, Palmer AM, Snape M, Wilcock GK. The cholinergic hypothesis of Alzheimer's disease: a review of progress. *J Neurol Neurosurg Psychiatry.* 1999; 66(2):137-47.
- Frey C et al. Apolipoprotein E epsilon 4 is associated with an increased vulnerability to cell death in Alzheimer's disease. *J Neural Transm.* 2006;113(11):1753-61.
- Gao B, Chen J, Johnson C, Kunos G. Both the cyclic AMP response element and the activator protein 2 binding site mediate basal and cyclic AMP-induced transcription from the dominant promoter of the rat alpha 1B-adrenergic receptor gene in DDT1MF-2 cells. *Mol Pharmacol.* 1997;52(6):1019-26.
- García MA, Vázquez J, Giménez C, Valdivieso F, Zafra F. Transcription factor AP-2 regulates human apolipoprotein E gene expression in astrocytoma cells. *J Neurosci.* 1996;16(23):7550-6.
- García MA, Campillos M, Marina A, Valdivieso F, Vázquez J. Transcription factor AP-2 activity is modulated by protein kinase A-mediated phosphorylation. *FEBS Lett.* 1999;444(1):27-31.
- Gaubatz S, Imhof A, Dosch R, Werner O, Mitchell P, Buettner R, Eilers M. Transcriptional activation by Myc is under negative control by the transcription factor AP-2. *EMBO J.* 1995;14(7):1508-19.
- Gee JR, Keller JN. Astrocytes: regulation of brain homeostasis via apolipoprotein E. *Int J Biochem Cell Biol.* 2005;37(6):1145-50.
- Georganopoulou DG, Chang L, Nam JM, Thaxton CS, Mufson EJ, Klein WL, Mirkin CA. Nanoparticle-based detection in cerebral spinal fluid of a soluble pathogenic biomarker for Alzheimer's disease. *Proc. Natl. Acad. Sci. U. S. A.* 2005; 102:2273–6.

- Goate AM, Haynes AR, Owen MJ, Farrall M, James LA, Lai LY, Mullan MJ, Roques P, Rossor MN, Williamson R, et al. Predisposing locus for Alzheimer's disease on chromosome 21. *Lancet*. 1989;1(8634):352-5.
- Goedert M, Spillantini MG. A century of Alzheimer's disease. *Science*. 2006; 314(5800):777-81.
- Goedert M and Ghetti B. Alois Alzheimer: his life and times. *Brain Pathol*. 2007;17(1):57-62.
- Goldberg LI. Recent advances in the pharmacology of catecholamines. *Intensive Care Med*. 1977;3(4):233-6.
- Golde TE, Estus S, Younkin LH, Selkoe DJ, Younkin SG. Processing of the amyloid protein precursor to potentially amyloidogenic derivatives. *Science*. 1992; 255(5045):728-30.
- Gorina Y, Hoyert D, Lentzner H, Goulding M. Trends in causes of death among older persons in the United States. *Aging Trends*. 2006: 6. National Center for Health Statistics. Hyattsville, Maryland.
- Göritz C, Mauch DH, Nägler K, Pfrieder FW. Role of glia-derived cholesterol in synaptogenesis: new revelations in the synapse-glia affair. *J Physiol Paris*. 2002;96(3-4):257-63.
- Grainger DJ, Reckless J, McKilligin E. Apolipoprotein E Modulates Clearance of Apoptotic Bodies In Vitro and In Vivo, Resulting in a Systemic Proinflammatory State in Apolipoprotein E-Deficient Mice. *The Journal of Immunology*. 2004;173: 6366–6375.
- Griffin WS, Stanley LC, Ling C, White L, MacLeod V, Perrot LJ, White CL III, Araoz C. Brain interleukin 1 and S-100 immunoreactivity are elevated in Down syndrome and Alzheimer disease. *Proc Natl Acad Sci USA*. 1989;86:7611–7615.
- Guénette SY. Astrocytes: a cellular player in Ab clearance and degradation. *Trends in Molecular Medicine* 2003;9(7): 279-80.
- Gutman, CR, Strittmatter WJ, Weisgraber KH, Matthew WD. Apolipoprotein E binds to and potentiates the biological activity of ciliary neurotrophic factor. *Journal of Neuroscience*. 1997; 17:6114–6121.

- Haasdijk ED, Vlug A, Mulder MT, Jaarsma D. Increased apolipoprotein E expression correlates with the onset of neuronal degeneration in the spinal cord of G93A-SOD1 mice. *Neurosci Lett*. 2002;335(1):29-33.
- Haass C, et al. Amyloid beta-peptide is produced by cultured cells during normal metabolism. *Nature*. 1992a; 359:322–5.
- Haass C, Koo EH, Mellon A, Hung AY, Selkoe DJ. Targeting of cell-surface beta-amyloid precursor protein to lysosomes: alternative processing into amyloid-bearing fragments. *Nature*. 1992b; 357(6378):500-3.
- Haass, C and Selkoe DJ. Cellular processing of β -amyloid precursor protein and the genesis of amyloid β -peptide. *Cell*. 1993; 75: 1039–1042.
- Hardy J, Allsop D. Amyloid deposition as the central event in the aetiology of Alzheimer's disease. *Trends Pharmacol Sci*. 1991;12(10):383-8.
- Hardy J. The amyloid hypothesis for Alzheimer's disease: a critical reappraisal. *J Neurochem*. 2009;110(4):1129-34.
- Hatters DM, Peters-Libeu CA, Weisgraber KH. Apolipoprotein E structure: insights into function. *Trends Biochem Sci*. 2006;31(8):445-54.
- Haydon PG. Glia: listening and talking to the synapse. *Nat Rev Neurosci* 2001; 2: 185–193.
- Heintz K, Beck M, Schliebs R, Perez-Polo JR. Toxicity mediated by soluble oligomers of beta-amyloid(1-42) on cholinergic SN56.B5.G4 cells. *J Neurochem*. 2006; 98(6):1930-45.
- Helmuth L. Neuroscience. Glia tell neurons to build synapses. *Science* 2001;291:569–70.
- Hertz L, Schousboe I, Hertz L, Schousboe A. Receptor expression in primary cultures of neurons or astrocytes. *Prog Neuropsychopharmacol Biol Psychiatry*. 1984;8(4-6):521-7.
- Hilger-Eversheim K, Moser M, Schorle H, Buettner R. Regulatory roles of AP-2 transcription factors in vertebrate development, apoptosis and cell-cycle control. *Gene*. 2000;260(1-2):1-12.
- Hirst WD, Cheung NY, Rattray M, Price GW, Wilkin GP. Cultured astrocytes express messenger RNA for multiple serotonin receptor subtypes, without functional coupling of 5-HT1 receptor subtypes to adenylyl cyclase. *Brain Res Mol Brain Res*. 1998;61(1-2):90-9.

- Hodges-Savola C, Rogers SD, Ghilardi JR, Timm DR, Mantyh PW. Beta-adrenergic receptors regulate astrogliosis and cell proliferation in the central nervous system in vivo. *Glia*. 1996;17(1):52-62.
- Holoubek G, Nöldner M, Treiber K, Müller WE. Effect of chronic antidepressant treatment on beta-receptor coupled signal transduction cascade. Which effect matters most? *Pharmacopsychiatry*. 2004;37 Suppl 2:S113-9.
- Holtzman DM et al. Apolipoprotein E isoform-dependent amyloid deposition and neuritic degeneration in a mouse model of Alzheimer's disease. *PNAS* 2000; 97(6):2892–2897.
- Hu J, LaDu MJ, Van Eldik LJ. Apolipoprotein E attenuates beta-amyloid-induced astrocyte activation. *J Neurochem*. 1998;71(4):1626-34.
- Huang Y, Domann FE. Redox modulation of AP-2 DNA binding activity in vitro. *Biochem Biophys Res Commun*. 1998;249(2):307-12.
- Huang Y. Apolipoprotein E and Alzheimer disease. *Neurology*. 2006;66(Suppl 1):S79–S85.
- Igbavboa U, Pidcock JM, Johnson LN, Malo TM, Studniski AE, Yu S, Sun GY, Wood WG. J Cholesterol distribution in the Golgi complex of DITNC1 astrocytes is differentially altered by fresh and aged amyloid beta-peptide-(1-42). *Biol Chem*. 2003;278(19):17150-7.
- Igbavboa U, Johnson-Anuna LN, Rossello X, Butterick TA, Sun GY, Wood WG. Amyloid beta-protein1-42 increases cAMP and apolipoprotein E levels which are inhibited by beta1 and beta2-adrenergic receptor antagonists in mouse primary astrocytes. *Neuroscience*. 2006;142(3):655-60.
- Igbavboa U, Sun GY, Weisman GA, He Y, Wood WG. Amyloid beta-protein stimulates trafficking of cholesterol and caveolin-1 from the plasma membrane to the Golgi complex in mouse primary astrocytes. *Neuroscience*. 2009;162(2):328-38.
- Ignatius MJ, Gebicke-Härter PJ, Skene JH, Schilling JW, Weisgraber KH, Mahley RW, Shooter EM. Expression of apolipoprotein E during nerve degeneration and regeneration. *Proc Natl Acad Sci U S A*. 1986;83(4):1125-9.
- Imagawa M, Chiu R, Karin M. Transcription factor AP-2 mediates induction by two different signal-transduction pathways: protein kinase C and cAMP. *Cell*. 1987;51(2):251-60.

- Irvine GB, El-Agnaf OM, Shankar GM, Walsh DM. Protein aggregation in the brain: the molecular basis for Alzheimer's and Parkinson's diseases. *Mol Med.* 2008;14(7-8):451-64.
- Junker V, Becker A, Hühne R, Zembatov M, Ravati A, Culmsee C, Kriegelstein J. Stimulation of beta-adrenoceptors activates astrocytes and provides neuroprotection. *Eur J Pharmacol.* 2002;446(1-3):25-36.
- Kim HJ, Chae SC, Lee DK, Chromy B, Lee SC, Park YC, Klein WL, Krafft GA, Hong ST. Selective neuronal degeneration induced by soluble oligomeric amyloid beta protein. *FASEB J.* 2003;17(1):118-20.
- Kim HJ, Kim JH, Chae SC, Park YC, Kwon KS, Hong ST. Soluble oligomeric Abeta disrupts the protein kinase C signaling pathway. *Neuroreport.* 2004;15(3):503-7.
- Kimura N, Negishi T, Ishii Y, Kyuwa S, Yoshikawa Y. Astroglial responses against Abeta initially occur in cerebral primary cortical cultures: species differences between rat and cynomolgus monkey. *Neurosci Res.* 2004 Jul;49(3):339-46.
- Kinsella, K and W He. U.S. Census Bureau, International Population Reports, P95/09-1, An Aging World: 2008, U.S. Government Printing Office, Washington, DC. 2009.
- Kirkitadze MD, Bitan G, Teplow DB. Paradigm shifts in Alzheimer's disease and other neurodegenerative disorders: the emerging role of oligomeric assemblies. *J Neurosci Res.* 2002;69(5):567-77.
- Klein WL, Stine WB Jr, Teplow DB. Small assemblies of unmodified amyloid beta-protein are the proximate neurotoxin in Alzheimer's disease. *Neurobiol Aging.* 2004;25(5):569-80.
- Koistinaho M, Lin S, Wu X, Esterman M, Koger D, Hanson J, Higgs R, Liu F, Malkani S, Bales KR, Paul SM. Apolipoprotein E promotes astrocyte colocalization and degradation of deposited amyloid-beta peptides. *Nat Med.* 2004;10(7):719-26.
- Kung HC, Hoyert DL, Xu JQ, Murphy SL. Deaths: Final data for 2005. National vital statistics reports. 2008: 56(10). National Center for Health Statistics. 2008. Hyattsville, MD.
- LaDu MJ, Reardon C, Van Eldik L, Fagan AM, Bu G, Holtzman D, Getz GS. Lipoproteins in the central nervous system. *Ann N Y Acad Sci.* 2000a;903:167-75.

- LaDu MJ, Shah JA, Reardon CA, Getz GS, Bu G, Hu J, Guo L, van Eldik LJ. Apolipoprotein E receptors mediate the effects of beta-amyloid on astrocyte cultures. *J Biol Chem.* 2000b;275(43):33974-80.
- LaDu MJ, Shah JA, Reardon CA, Getz GS, Bu G, Hu J, Guo L, Van Eldik LJ. Apolipoprotein E and apolipoprotein E receptors modulate A beta-induced glial neuroinflammatory responses. *Neurochem Int.* 2001;39(5-6):427-34.
- Lahiri DK. Apolipoprotein E as a target for developing new therapeutics for Alzheimer's disease based on studies from protein, RNA, and regulatory region of the gene. *J Mol Neurosci.* 2004;23(3):225-33.
- Lambert MP et al. Diffusible, nonfibrillar ligands derived from Abeta1-42 are potent central nervous system neurotoxins. *Proc Natl Acad Sci U S A.* 1998;95(11):6448-53.
- Lee Y, Aono M, Laskowitz D, Warner DS, Pearlstein RD. Apolipoprotein E protects against oxidative stress in mixed neuronal-glial cell cultures by reducing glutamate toxicity. *Neurochemistry International.* 2004; 44:107–118.
- Lenard NR, Gettys TW, Dunn AJ. Activation of beta2- and beta3-adrenergic receptors increases brain tryptophan. *J Pharmacol Exp Ther.* 2003;305(2):653-9.
- Levi O, Lütjohann D, Devir A, von Bergmann K, Hartmann T, Michaelson DM. Regulation of hippocampal cholesterol metabolism by apoE and environmental stimulation. *J Neurochem.* 2005;95(4):987-97.
- Li H, Goswami PC, Domann FE. AP-2gamma induces p21 expression, arrests cell cycle, and inhibits the tumor growth of human carcinoma cells. *Neoplasia.* 2006;8(7):568-77.
- LiCalsi C, Christophe S, Steger DJ, Buescher M, Fischer W, Mellon PL. AP-2 family members regulate basal and cAMP-induced expression of human chorionic gonadotropin. *Nucleic Acids Res.* 2000;28(4):1036-43.
- Lin-Lee YC, Kao FT, Cheung P, Chan L. Apolipoprotein E gene mapping and expression: localization of the structural gene to human chromosome 19 and expression of ApoE mRNA in lipoprotein- and non-lipoprotein-producing tissues. *Biochemistry.* 1985; 24:3751—3756.
- Lüscher B, Mitchell PJ, Williams T, Tjian R. Regulation of transcription factor AP-2 by the morphogen retinoic acid and by second messengers. *Genes Dev.* 1989;3(10):1507-17.

- Lynch JR, Morgan D, Mance J, Matthew WD, Laskowitz DT. Apolipoprotein E modulates glial activation and the endogenous central nervous system inflammatory response. *J Neuroimmunol.* 2001;114(1-2):107-13.
- Mahley RW. Apolipoprotein E: Cholesterol transport protein with expanding role in cell biology. *Science* 1988;240:622–630.
- Maloney B, Ge YW, Alley GM, Lahiri DK. Important differences between human and mouse APOE gene promoters: limitation of mouse APOE model in studying Alzheimer's disease. *J Neurochem.* 2007;103(3):1237-57.
- Manelli AM, Stine WB, Van Eldik LJ, LaDu MJ. ApoE and Abeta1-42 interactions: effects of isoform and conformation on structure and function. *J Mol Neurosci.* 2004;23(3):235-46.
- Manelli AM, Bulfinch LC, Sullivan PM, LaDu MJ. Abeta42 neurotoxicity in primary co-cultures: effect of apoE isoform and Abeta conformation. *Neurobiol Aging.* 2007;28(8):1139-47.
- Mantyh PW, Rogers SD, Allen CJ, Catton MD, Ghilardi JR, Levin LA, Maggio JE, Vigna SR. Beta 2-adrenergic receptors are expressed by glia in vivo in the normal and injured central nervous system in the rat, rabbit, and human. *J Neurosci.* 1995;15(1 Pt 1):152-64.
- Maragakis NJ, Rothstein JD. Mechanisms of Disease: astrocytes in neurodegenerative disease. *Nat Clin Pract Neurol.* 2006;2(12):679-89.
- Martínez M, Fernández E, Frank A, Guaza C, de la Fuente M, Hernanz A. Increased cerebrospinal fluid cAMP levels in Alzheimer's disease. *Brain Res.* 1999;846(2):265-7
- Martínez M, Hernández AI, Hernanz A. Increased cAMP immunostaining in cerebral vessels in Alzheimer's disease. *Brain Res.* 2001;922(1):148-52.
- Martínez-González NA and CLM Sudlow. Effects of apolipoprotein E genotype on outcome after ischaemic stroke, intracerebral haemorrhage and subarachnoid haemorrhage. *J. Neurol. Neurosurg. Psychiatry* 2006;77:1329-1335.
- Mason RP, Jacob RF, Walter MF, Mason PE, Avdulov NA, Chochina SV, Igbavboa U, Wood WG. Distribution and fluidizing action of soluble and aggregated amyloid beta-peptide in rat synaptic plasma membranes. *J Biol Chem.* 1999; 274(26):18801-7

- Mazina OM, Phillips MA, Williams T, Vines CA, Cherr GN, Rice RH. Redistribution of transcription factor AP-2alpha in differentiating cultured human epidermal cells. *J Invest Dermatol.* 2001;117(4):864-70.
- McLean CA et al. Soluble pool of Abeta amyloid as a determinant of severity of neurodegeneration in Alzheimer's disease. *Ann. Neurol.* 1999; 46:860-6.
- McManus MF, Chen LC, Vallejo I, Vallejo M. Astroglial differentiation of cortical precursor cells triggered by activation of the cAMP-dependent signaling pathway. *J Neurosci.* 1999;19(20):9004-15.
- Meda L, Baron P, Scarlato G. Glial activation in Alzheimer's disease: the role of AB and its associated proteins. *Neurobiology of Aging.* 2001; 22:885-893.
- Michikawa M, Fan QW, Isobe I, Yanagisawa K. Apolipoprotein E Exhibits Isoform-Specific Promotion of Lipid Efflux from Astrocytes and Neurons in Culture. *J. Neurochem.* 2000; 74:1008-1016.
- Michikawa M, Gong JS, Fan QW, Sawamura N, Yanagisawa K. A novel action of alzheimer's amyloid beta-protein (Abeta): oligomeric Abeta promotes lipid release. *J Neurosci.* 2001;21(18):7226-35.
- Misra UK, Adlakha CL, Gawdi G, McMillian MK, Pizzo SV, Laskowitz DT. Apolipoprotein E and mimetic peptide initiate a calcium-dependent signaling response in macrophages. *Journal of Leukocyte Biology.* 2001; 70, 677-683.
- Mitchell PJ, Wang C, Tjian R. Positive and negative regulation of transcription in vitro: enhancer-binding protein AP-2 is inhibited by SV40 T antigen. *Cell.* 1987;50(6):847-61.
- Mitchell PJ, Timmons PM, Hébert JM, Rigby PW, Tjian R. Transcription factor AP-2 is expressed in neural crest cell lineages during mouse embryogenesis. *Genes Dev.* 1991;5(1):105-19.
- Molnár Z, Kovács P, Laczkó I, Soós K, Fülöp L, Penke B, Lengyel I. Enhanced G-protein activation by a mixture of Abeta(25-35), Abeta(1-40/42) and zinc. *J Neurochem.* 2004;89(5):1215-23.
- Morin D, Sapena R, Zini R, Onteniente B, Tillement JP. Characterization of beta-adrenergic receptors of freshly isolated astrocytes and neurons from rat brain. *Life Sci.* 1997;60(4-5):315-24.

- Morin D, Sapena R, Tillement JP, Urien S. Evidence for different interactions between beta(1)- and beta(2)-adrenoceptor subtypes with adenylyl cyclase in the rat brain: a concentration-response study using forskolin. *Pharmacol Res.* 2000;41(4):435-43.
- Moser M, Imhof A, Pscherer A, Bauer R, Amselgruber W, Sinowatz F, Hofstädter F, Schüle R, Buettner R. Cloning and characterization of a second AP-2 transcription factor: AP-2 beta. *Development.* 1995;121(9):2779-88.
- Moser M, Rüschoff J, Buettner R. Comparative analysis of AP-2 alpha and AP-2 beta gene expression during murine embryogenesis. *Dev Dyn.* 1997;208(1):115-24.
- Mossello E, Boncinelli M, Caleri V, Cavallini MC, Palermo E, Di Bari M, Tilli S, Sarcone E, Simoni D, Biagini CA, Masotti G, Marchionni N. Is antidepressant treatment associated with reduced cognitive decline in Alzheimer's disease? *Dement Geriatr Cogn Disord.* 2008;25(4):372-9.
- Muller W, Meske V, Baerlin K, Scharnagl H, Marz W, Ohm, TG. Apolipoprotein E isoforms increase intracellular Ca²⁺ differentially through a omega-agatoxin IVa-sensitive Ca²⁺- channel. *Brain Pathology.* 1998; 8: 641-653.
- Nathan BP, Jiang Y, Wong GK, Shen F, Brewer GJ, Struble RG. Apolipoprotein E4 inhibits, and apolipoprotein E3 promotes neurite outgrowth in cultured adult mouse cortical neurons through the low-density lipoprotein receptor-related protein. *Brain Res.* 2002;928(1-2):96-105.
- Neve RL, Finch EA, Dawes LR. Expression of the Alzheimer amyloid precursor gene transcripts in the human brain. *Neuron.* 1988;1(8):669-77.
- Newman SP, Bates NP, Vernimmen D, Parker MG, Hurst HC. Cofactor competition between the ligand-bound oestrogen receptor and an intron 1 enhancer leads to oestrogen repression of ERBB2 expression in breast cancer. *Oncogene.* 2000;19(4):490-7.
- Nielsen HM, Veerhuis R, Holmqvist B, Janciauskiene S. Binding and uptake of A beta1-42 by primary human astrocytes in vitro. *Glia.* 2009;57(9):978-88.
- Nishizuka Y. Studies and perspectives of protein kinase C. *Science.* 1986;233(4761):305-12.
- Nyormoi O, Wang Z, Doan D, Ruiz M, McConkey D, Bar-Eli M. Transcription factor AP-2alpha is preferentially cleaved by caspase 6 and degraded by proteasome during tumor necrosis factor alpha-induced apoptosis in breast cancer cells. *Mol Cell Biol.* 2001;21(15):4856-67.

- Octave JN. The amyloid peptide and its precursor in Alzheimer's disease. *Rev. Neurosci.* 1995; 6: 287–316.
- Otte AP, van Run P, Heideveld M, van Driel R, Durston AJ. Neural induction is mediated by cross-talk between the protein kinase C and cyclic AMP pathways. *Cell.* 1989;58(4):641-8.
- Oulad-Abdelghani M, Bouillet P, Chazaud C, Dollé P, Chambon P. AP-2.2: a novel AP-2-related transcription factor induced by retinoic acid during differentiation of P19 embryonal carcinoma cells. *Exp Cell Res.* 1996;225(2):338-47.
- Oyama F, Shimada H, Oyama R, Ihara Y. Apolipoprotein E genotype, Alzheimer's pathologies and related gene expression in the aged population. *Brain Res Mol Brain Res.* 1995;29(1):92-8.
- Panaszek B, Machaj Z, Bogacka E, Lindner K. Chronic disease in the elderly: a vital rationale for the revival of internal medicine. *Pol Arch Med Wewn.* 2009;119(4):248-54.
- Paradisi S, Sacchetti B, Balduzzi M, Gaudi S, Malchiodi-Albedi F. Astrocyte modulation of in vitro beta-amyloid neurotoxicity. *Glia.* 2004;46(3):252-60.
- Parihar MS, Hemnani T. Alzheimer's disease pathogenesis and therapeutic interventions. *J Clin Neurosci.* 2004;11(5):456-67.
- Park K and Kim KH. The site of cAMP action in the insulin induction of gene expression of acetyl-CoA carboxylase is AP-2. *J Biol Chem.* 1993;268(24):17811-9.
- Parvathy S, Hussain I, Karran EH, Turner AJ, Hooper NM. Cleavage of Alzheimer's amyloid precursor protein by alpha-secretase occurs at the surface of neuronal cells. *Biochemistry.* 1999;38(30):9728-34.
- Pellikainen JM, Kosma VM. Activator protein-2 in carcinogenesis with a special reference to breast cancer--a mini review. *Int J Cancer.* 2007;120(10):2061-7.
- Philipp J, Mitchell PJ, Malipiero U, Fontana A. Cell type-specific regulation of expression of transcription factor AP-2 in neuroectodermal cells. *Dev Biol.* 1994; 165(2):602-14.
- Pihlaja R, Koistinaho J, Malm T, Sikkilä H, Vainio S, Koistinaho M. Transplanted astrocytes internalize deposited beta-amyloid peptides in a transgenic mouse model of Alzheimer's disease. *Glia.* 2008;56(2):154-63.

- Pitas RE, Boyles JK, Lee SH, Foss D, Mahley RW. Astrocytes synthesize apolipoprotein E and metabolize apolipoprotein E-containing lipoproteins. *Biochim Biophys Acta*. 1987; 917: 148–61.
- Poirier J. Apolipoprotein E and Alzheimer's disease. A role in amyloid catabolism. *Ann N Y Acad Sci*. 2000;924:81-90.
- Poirier J. Apolipoprotein E, cholesterol transport and synthesis in sporadic Alzheimer's disease. *Neurobiol Aging*. 2005;26(3):355-61.
- Porter JT and McCarthy KD. Astrocytic neurotransmitter receptors in situ and in vivo. *Prog Neurobiol*. 1997;51(4):439-55.
- Prapong T, Uemura E, Hsu WH. G protein and cAMP-dependent protein kinase mediate amyloid beta-peptide inhibition of neuronal glucose uptake. *Exp Neurol*. 2001;167(1):59-64.
- Prince M et al. Ageing and dementia in low and middle income countries-Using research to engage with public and policy makers. *Int Rev Psychiatry*. 2008;20(4):332-43.
- Rall Jr. SC, Weisgraber KH, Mahley RW. Human apolipoprotein E. The complete amino acid sequence. *J Biol Chem* 1982;257:4171–4178.
- Ramos BP, Colgan LA, Nou E, Arnsten AF. Beta2 adrenergic agonist, clenbuterol, enhances working memory performance in aging animals. *Neurobiol Aging*. 2008;29(7):1060-9.
- Rao JS, Rapoport SI, Bosetti F. Decrease in the AP-2 DNA-binding activity and in the protein expression of AP-2 alpha and AP-2 beta in frontal cortex of rats treated with lithium for 6 weeks. *Neuropsychopharmacology*. 2005;30(11):2006-13.
- Rapp A, Gmeiner B, Hüttinger M. Implication of apoE isoforms in cholesterol metabolism by primary rat hippocampal neurons and astrocytes. *Biochimie*. 2006;88(5):473-83.
- Rebeck GW, Kindy M, LaDu MJ. Apolipoprotein E and Alzheimer's disease: the protective effects of ApoE2 and E3. *J Alzheimers Dis*. 2002;4(3):145-54.
- Ribalta J, Vallve JC, Girona J, Masana L. Current Apolipoprotein and apolipoprotein receptor genes, blood lipids and disease. *Opinion in Clinical Nutrition and Metabolic Care*. 2003; 6:177–187.
- Roßner S. New players in old amyloid precursor protein-processing pathways. *Int J Dev Neurosci*. 2004;22(7):467-74.

- Robinson SR, Bishop GM. Ab as a bioflocculant: implications for the amyloid hypothesis of Alzheimer's disease. *Neurobiol Aging* 2002; 23(6): 1051–1072.
- Roesler WJ, Vandenbark GR, Hanson RW. Cyclic AMP and the induction of eukaryotic gene transcription. *J Biol Chem.* 1988;263(19):9063-6.
- Rosenberg PA, Li Y. Adenylyl cyclase activation underlies intracellular cyclic AMP accumulation, cyclic AMP transport, and extracellular adenosine accumulation evoked by beta-adrenergic receptor stimulation in mixed cultures of neurons and astrocytes derived from rat cerebral cortex. *Brain Res.* 1995;692(1-2):227-32.
- Roychaudhuri R, Yang M, Hoshi MM, Teplow DB. Amyloid beta-protein assembly and Alzheimer disease. *J Biol Chem.* 2009;284(8):4749-53.
- Rozengurt E. Early signals in the mitogenic response. *Science.* 1986;234(4773):161-6.
- Rymer DL, Good TA. The role of G protein activation in the toxicity of amyloidogenic Abeta-(1-40), Abeta-(25-35), and bovine calcitonin. *J Biol Chem.* 2001;276(4):2523-30.
- Saitoh T, Horsburgh K, Masliah E. Hyperactivation of signal transduction systems in Alzheimer's disease. *Ann N Y Acad Sci.* 1993;695:34-41.
- Salm AK, McCarthy KD. Expression of beta-adrenergic receptors by astrocytes isolated from adult rat cortex. *Glia.* 1989;2(5):346-52.
- Seitz A, Kragol M, Aglow E, Showe L, Heber-Katz E. Apolipoprotein E expression after spinal cord injury in the mouse. *J Neurosci Res.* 2003;71(3):417-26.
- Semkova I, Schilling M, Henrich-Noack P, Rami A, Krieglstein J. Clenbuterol protects mouse cerebral cortex and rat hippocampus from ischemic damage and attenuates glutamate neurotoxicity in cultured hippocampal neurons by induction of NGF. *Brain Res.* 1996;717(1-2):44-54.
- Seubert P et al. Secretion of beta-amyloid precursor protein cleaved at the amino terminus of the beta-amyloid peptide. *Nature.* 1993;361(6409):260-3.
- Shah RS, Lee HG, Xiongwei Z, Perry G, Smith MA, Castellani RJ. Current approaches in the treatment of Alzheimer's disease. *Biomed Pharmacother.* 2008;62(4):199-207.
- Shain W, Forman DS, Madelian V, Turner JN. Morphology of astroglial cells is controlled by beta-adrenergic receptors. *J Cell Biol.* 1987;105(5):2307-14.

- Shao Y and Sutin J. Expression of adrenergic receptors in individual astrocytes and motor neurons isolated from the adult rat brain. *Glia*. 1992;6(2):108-17.
- Shimada M, Konishi Y, Ohkawa N, Ohtaka-Maruyama C, Hanaoka F, Makino Y, Tamura T. Distribution of AP-2 subtypes in the adult mouse brain. *Neurosci Res*. 1999;33(4):275-80.
- Simard M and Nedergaard M. The neurobiology of glia in the context of water and ion homeostasis. *Neuroscience*. 2004; 129: 877–896.
- Sinha S, Lieberburg I. Cellular mechanisms of beta-amyloid production and secretion. *Proc Natl Acad Sci U S A*. 1999;96(20):11049-53.
- Sisodia SS. Beta-amyloid precursor protein cleavage by a membrane bound protease. *Proc. Natl. Acad. Sci. USA* 1992; 89:6075–6079.
- Sisodia SS and Price DL. Role of the β -amyloid protein in Alzheimer's disease. *FASEB J*. 1995; 9:366–370.
- Sparks DL, Hunsaker JC 3rd, Scheff SW, Kryscio RJ, Henson JL, Markesbery WR. Cortical senile plaques in coronary artery disease, aging and Alzheimer's disease. *Neurobiol Aging*. 1990;11(6):601-7.
- St George-Hyslop. Piecing Together Alzheimer's. *Scientific American*. 2000 Dec. 76-83.
- Strittmatter WJ, Saunders AM, Schmechel D, Pericak-Vance M, Enghild J, Salvesen G S, Roses AD. Apolipoprotein E: high avidity binding to β -amyloid and increased frequency of type 4 allele in late-onset familial Alzheimer disease. *Proc. Natl. Acad. Sci. USA*. 1993;90:1977–1981.
- Strittmatter WJ, Bova Hill C. Molecular biology of apolipoprotein E. *Curr Opin Lipidol*. 2002;13(2):119-23.
- Sulser F, Vetulani J, Mobley PL. Mode of action of antidepressant drugs. *Biochem Pharmacol*. 1978;27(3):257-61.
- Suzuki N et al. An increased percentage of long amyloid beta protein secreted by familial amyloid beta protein precursor (beta APP717) mutants. *Science*. 1994; 264(5163):1336-40.
- Tabaton M, Piccini A. Role of water-soluble amyloid-beta in the pathogenesis of Alzheimer's disease. *Int J Exp Pathol*. 2005;86(3):139-45.

- Takano T et al. Astrocyte-mediated control of cerebral blood flow. *Nat Neurosci* 2006; 9: 260–267.
- Tamagno E, Bardini P, Guglielmotto M, Danni O, Tabaton M. The various aggregation states of beta-amyloid 1-42 mediate different effects on oxidative stress, neurodegeneration, and BACE-1 expression. *Free Radic Biol Med*. 2006; 41(2):202-12.
- Taskén K, Aandahl EM. Localized effects of cAMP mediated by distinct routes of protein kinase A. *Physiol Rev*. 2004;84(1):137-67.
- Tedeschi G, Cirillo M, Tessitore A, Cirillo S. Alzheimer's disease and other dementing conditions. *Neurol Sci*. 2008;29 Suppl 3:301-7.
- Terry RD, et al. Physical basis of cognitive alterations in Alzheimer's disease: synapse loss is the major correlate of cognitive impairment. *Ann. Neurol*. 1991; 30:572–80.
- Thinakaran G, Koo EH. Amyloid precursor protein trafficking, processing, and function. *J Biol Chem*. 2008;283(44):29615-9.
- Tokuda T et al. Lipidation Of Apolipoprotein E Influences Its Isoform-Specific Interaction With Alzheimer's Amyloid B Peptides. *Biochem. J*. 2000;348: 359-365.
- Tummala R, Romano RA, Fuchs E, Sinha S. Molecular cloning and characterization of AP-2 epsilon, a fifth member of the AP-2 family. *Gene*. 2003;321:93-102.
- Van Eldik LJ, Griffin WS. S100 beta expression in Alzheimer's disease: relation to neuropathology in brain regions. *Biochim Biophys Acta* 1994;1223:398–403.
- van Marum RJ. Current and future therapy in Alzheimer's disease. *Fundam Clin Pharmacol*. 2008;22(3):265-74.
- Vance JE, Hayashi H, Karten B. Cholesterol homeostasis in neurons and glial cells. *Semin Cell Dev Biol*. 2005;16(2):193-212.
- Vassar R et al. Beta-secretase cleavage of Alzheimer's amyloid precursor protein by the transmembrane aspartic protease BACE. *Science*. 1999;286(5440):735-41.
- Vigo-Pelfrey C, Lee D, Keim P, Lieberburg I, Schenk DB. Characterization of betaamyloid peptide from human cerebrospinal fluid. *J. Neurochem*. 1993; 61:1965–8.

- Voutsinos-Porche B et al.. Glial Glutamate Transporters mediate a Functional Metabolic Crosstalk between Neurons and Astrocytes in the Mouse Developing Cortex. *Neuron*, 2003; 7:275–286.
- Walsh DM, Tseng BP, Rydel RE, Podlisny MB, Selkoe DJ. The oligomerization of amyloid beta-protein begins intracellularly in cells derived from human brain. *Biochemistry* 2000; 39:10831–9.
- Walsh DM, Klyubin I, Fadeeva JV, Rowan MJ, Selkoe DJ. Amyloid-beta oligomers: their production, toxicity and therapeutic inhibition. *Biochem Soc Trans.* 2002; 30(4):552-7.
- Walton KM, Rehfuss RP. Molecular mechanisms of cAMP-regulated gene expression. *Mol Neurobiol.* 1990 Fall-Winter;4(3-4):197-210.
- Wang HV, Vaupel K, Buettner R, Bosserhoff AK, Moser M. Identification and embryonic expression of a new AP-2 transcription factor, AP-2 epsilon. *Dev Dyn.* 2004;231(1):128-35.
- Watson D et al. Physicochemical characteristics of soluble oligomeric Abeta and their pathologic role in Alzheimer's disease. *Neurol Res.* 2005;27(8):869-81.
- Wegiel J, Wang KC, Tarnawski M, Lach B. Microglia cells are the driving force in fibrillar plaque formation, whereas astrocytes are a leading factor in plaque degradation. *Acta Neuropathol.* 2000;100(4):356-64.
- Weidemann A, König G, Bunke D, Fischer P, Salbaum JM, Masters CL, Beyreuther K. Identification, biogenesis, and localization of precursors of Alzheimer's disease A4 amyloid protein. *Cell.* 1989;57(1):115-26.
- Weisgraber KH, Rall Jr. SC, Mahley RW. Human E apoprotein heterogeneity. Cysteine-arginine interchanges in the amino acid sequence of the apo-E isoforms. *J Biol Chem* 1981;256:9077–9083.
- Weisgraber KH, Roses AD, Strittmatter WJ. The role of apolipoprotein E in the nervous system. *Curr Opin Lipidol.* 1994;5(2):110-6.
- Williams T, Admon A, Lüscher B, Tjian R. Cloning and expression of AP-2, a cell-type-specific transcription factor that activates inducible enhancer elements. *Genes Dev.* 1988;2(12A):1557-69.
- Williams T, Tjian R. Analysis of the DNA-binding and activation properties of the human transcription factor AP-2. *Genes Dev.* 1991;5(4):670-82.

- Wirhth O, Multhaup G, Bayer TA. A modified beta-amyloid hypothesis: intraneuronal accumulation of the beta-amyloid peptide--the first step of a fatal cascade. *J Neurochem.* 2004;91(3):513-20.
- Wisniewski HM, Wegiel J. Spatial relationships between astrocytes and classical plaque components. *Neurobiol Aging* 1991;12:593–600.
- Wöltje M, Kraus J, Höllt V. Regulation of mouse delta-opioid receptor gene transcription: involvement of the transcription factors AP-1 and AP-2. *J Neurochem.* 2000;74(4):1355-62.
- Wu G, Yuan J, Hunninghake DB. Effect of human apolipoprotein E isoforms on plasma lipids, lipoproteins and apolipoproteins in apolipoprotein E-deficient mice. *Atherosclerosis.*1998;141:287–296.
- Wyss-Coray T, Loike JD, Brionne TC, Lu E, Anankov R, Yan F, Silverstein SC, Husemann J. Adult mouse astrocytes degrade amyloid-beta in vitro and in situ. *Nat Med.* 2003;9(4):453-7.
- Xu J, Kochanek KD, Tejada-Vera B. Deaths: Preliminary data for 2007. National vital statistics reports. 2009;58(1). National Center for Health Statistics. Hyattsville, MD.
- Yamada T, Kondo A, Takamatsu J, Tateishi J, Goto I. Apolipoprotein E mRNA in the brains of patients with Alzheimer's disease. *J Neurol Sci.* 1995;129(1):56-61.
- Yamauchi K, Tozuka M, Hidaka E, Ueno I, Matsuda K, Katsuyama T. Internalization of beta-amyloid causes downregulation of apolipoprotein E mRNA expression in neuroblastoma cells. *Ann Clin Lab Sci.* 2003;33(1):68-78.
- Yankner BA, Lu T. Amyloid beta-protein toxicity and the pathogenesis of Alzheimer disease. *J Biol Chem.* 2009;284(8):4755-9.
- Ye ZC et al. Functional hemichannels in astrocytes: a novel mechanism of glutamate release. *J Neurosci.* 2003; 23: 3588–3596.
- Zarow C and J Victoroff. Increased Apolipoprotein E mRNA in the Hippocampus in Alzheimer Disease and in Rats after Entorhinal Cortex Lesioning. *Experimental Neurology* 1998; 149:79–86.
- Zarow C, Victoroff J. Increased apolipoprotein E mRNA in the hippocampus in Alzheimer disease and in rats after entorhinal cortex lesioning. *Exp Neurol.* 1998;149(1):79-86.

- Zhang Y, Luo Y, Zhai Q, Ma L, Dorf ME. Negative role of cAMP-dependent protein kinase A in RANTES-mediated transcription of proinflammatory mediators through Raf. *FASEB J*. 2003;17(6):734-6.
- Zhao F, Satoda M, Licht JD, Hayashizaki Y, Gelb BD. Cloning and characterization of a novel mouse AP-2 transcription factor, AP-2delta, with unique DNA binding and transactivation properties. *J Biol Chem*. 2001;276(44):40755-60.
- Zhao F, Lufkin T, Gelb BD. Expression of Tfp2d, the gene encoding the transcription factor Ap-2 delta, during mouse embryogenesis. *Gene Expr Patterns*. 2003;3(2):213-7.
- Zheng P, Pennacchio LA, Le Goff W, Rubin EM, Smith JD. Identification of a novel enhancer of brain expression near the apoE gene cluster by comparative genomics. *Biochim Biophys Acta*. 2004;1676(1):41-50.