

A STOCHASTIC EQUILIBRIUM MODEL
OF THE INTEREST RATE*

by

Alfonso Novales**

Discussion Paper No. 177, June, 1983

Center for Economic Research
Department of Economics
University of Minnesota
Minneapolis, Minnesota 55455

* Presented at the Meetings of the
Econometric Society, held in New
York in December, 1982.

** University of Minnesota

I am indebted to Christopher A. Sims for his continuous
encouragement and helpful suggestions. Any remaining
errors are my own.

1. INTRODUCTION

A feature common to most consumption and investment theories is the treatment of the interest rate as either constant over time, or as moving in a deterministic way. In particular, in Friedman's Permanent Income (4) and in Ando and Modigliani's Life Cycle (1) theories of consumption, consumers are assumed to take the interest rate as a given constant when computing their optimal decisions. As a result, the interest rate does not play an essential role in that decision process. More recently, dynamic stochastic models of consumption have not assigned a great importance to the interest rate in explaining how the consumers take intertemporal decisions either. In one of the best known models of this class, Hall (6), uncertainty emerges from unknown future income levels, while the interest rate is again supposed to be a known constant. As Sims has remarked (21), this assumption implies that the time path of income affects the level but not the shape of the optimal consumption path. This will be efficient when investment, defined as the gap between income and consumption, can be varied at no cost. However, in realistic environments, that will not be the case.

Perhaps the motivation underlying the assumption of a constant interest rate has been the analytical difficulty of treating the interest rate as time variant. In the case of an interest rate that varies over time, consumers' behavior then follows the path that optimizes their objective function subject to nonlinear constraints. However, it should be clear that the assumption of a known interest rate is not innocuous. As Hall said: "If the real interest rate varies over time in a way that is known for certain in advance, the results would remain true with minor amendments.(...) On

the other hand, if the real rate of interest applicable between periods t and $t+1$ is uncertain at the time the consumption decision in period t is made, then the theoretical results no longer apply." (p. 976)

The interest rate has been treated in a similar fashion in the existing investment theories. Jorgenson (10) assumed a constant interest rate that discounts future revenues and is also a component of the user cost of capital. Lucas and Prescott's model (16) deals with a randomly shifting product demand. In particular, the interest rate is treated in a similar way as in Jorgenson's model to obtain as a condition for an interior stationary equilibrium that the expected marginal product value of capital be equal to the rental price or user cost of capital. Lucas (15) arrives at the same kind of condition. These models postulate the existence of a perfect capital market where all economic agents, including firms are in a position to borrow or lend, at each point in time, as much as they wish, at the going rate of interest. Once again, Nickell (17) has explained that no essential change is produced in these investment models when the interest rate is considered to be time varying in a deterministic way, but "... the simplicity of a perfect capital market world breaks down completely if individuals are uncertain about, or have different expectations concerning, the future values of the interest rate." (p. 6)

The main thesis of this paper is that the interest rate has to be formulated as a stochastic process determined by the interaction of the optimal consumption and investment decisions of the economic agents, that occur simultaneously. From this point of view, it is not surprising that studies that focus on either the consumption or the investment decision alone, have to consider the interest rate as being constant or varying over time in a deterministic way.

The suggestion that optimal consumption and investment decisions be jointly studied, is hardly new in macroeconomics. The first work on investment theory, Fisher's The Theory of Interest (3), was a study of these joint optimal decisions in an economy with production. In a reexamination of Fisher's model, Hirshleifer (9) criticized some other solutions to the investment problem that had been proposed by Boulding, Samuelson, Scitovsky and Lutz and Lutz, saying: "Their common error lay in searching for a rule or formula which would indicate optimal investment decisions independently of consumption decisions." (p. 329) In financial economics, some literature that studies the existence of competitive equilibrium in pure exchange economies with securities can be viewed as a study of jointly optimal consumption and investment decisions. (See, for example, J. Green (5) and O. Hart (8)). In a recent paper, Roll (18) considers simultaneous consumption-investment decisions under uncertainty in a two period economy to study the relations between asset prices and individual expectations, risk and time preferences.

In the model I present, economic agents are infinitely lived and make optimal consumption and investment decisions simultaneously. The interest rate follows a stochastic process whose nature depends upon economic agents' decisions. As a result, the equilibrium value of the interest rate is consistent with both optimal consumption and investment plans. This formulation allows us to address questions concerning joint fluctuations of aggregate consumption, investment and the interest rate over time. In turn, the joint evolution of these macroeconomic variables is of interest in explaining business cycle fluctuations. A methodology recently employed to study macroeconomic fluctuations is the fitting of vector autoregressive models to macroeconomic actual data. One of the regularities emerging from that research is a delayed, negative response of output to an instantaneous

positive shock in the interest rate, as has been documented in Litterman and Weiss (14) and in Sims (21)¹. A more striking implication of this kind of research is that the money stock seems to Granger cause income and inflation when we do not include the interest rate in the model. However, when the interest rate is included, then money loses its active role, and the interest rate seems to cause everything else, including the money stock.

There is as yet no behavioral model that accounts for the delayed, negative response of output as well as the paradoxical Granger causal ordering of money and the interest rate. Regarding the latter, Sims has suggested (21) that some financial variables might reflect market participants' advance information concerning future random shocks to technology. The money stock would react to those shocks with some inertia, and output and prices would react with an even longer delay. The idea is that variables that react instantly to new information tend to appear as exogenous with respect to variables with more inertia.

Furthermore, Sims' comments suggest an approach to explain the delayed and negative output response. Interest rates reflect or anticipate future supply shocks. This paper utilizes this interpretation of the interest rate behavior together with an optimizing relationship between consumption and interest rates to determine the intertemporal allocation of consumption. At each point in time, consumers invest part of their resources, which produces interest returns next period. Consumers' utility function incorporates penalties for changes in consumption over short periods of time. A current jump in the equilibrium value of the interest rate signals a future drop in income, and hence a decrease in future consumption possibilities. When consumers perceive such a movement, they adjust

downwards their consumption paths so as to avoid large disutilities in the periods to come. This view would predict that the smaller weight consumption changes have in the utility function, the deeper the foreseen income trough has to be in order to produce a jump in today's interest rate by a given amount. Income,-- the process that is treated parametrically --, is stochastic, and therefore consumers solve an optimization problem under uncertainty. Since the problem lacks a linear - quadratic structure, we need a methodology different from the one used in standard dynamic stochastic rational expectations models. (See Hansen and Sargent (7), Sargent (19), (20)). I will follow here the techniques introduced by Kushner (12), (13).

This paper's model should be seen as the first step in the direction of research that has been outlined above. There is no money in the model, and therefore some of the empirical observations I have pointed out before can not be studied in it. However, the model is able to produce the delayed, negative response of output to an instantaneous shock in the interest rate. That matches one of the above mentioned observations and replicates the results obtained by Sims (21) working with a deterministic interest rate.

The paper is organized as follows: I present in Section 2 a stochastic environment where economic agents make optimal consumption and investment decisions simultaneously. These decisions together determine in equilibrium the value of the interest rate. In Section 3, I describe simulated solutions of the model and some comments on the results. Finally, Section 4 contains the conclusions and some conjectures for further research.

2. A MONETARY ECONOMY WITH STORAGE

Let us consider an economy with a single commodity which is supposed to be infinitely divisible and storable. People in this economy derive utility from consumption. They are identical individuals, or alternatively, we can think of them as being just a single economic agent. The typical consumer appreciates having a consumption path as smooth as possible and gets some disutility from changes in consumption over two or three successive periods. To capture this idea, the single period utility function depends on the values of consumption at different points in time. We suppose that the distaste for changes in consumption is symmetric, i.e., consumers penalize in the same way increases or decreases in their optimal consumption path over time. The reason for assuming this is to avoid an excessive parametrization, but no essential change in the results should be expected by dropping this assumption.

At the beginning of each period, consumers receive a certain quantity of the commodity from outside the economy. That quantity is random, but everybody knows the structure of the stochastic process from which it is drawn. They consume part of this stochastic endowment and store the rest until next period. Consumers pay storage costs at the beginning of each period for what they saved last period. They are assumed to maximize their expected discounted utility:

$$\text{Max } E_0 \tilde{U} = E_0 \sum_{t=0}^{\infty} \beta^t U(C_t, (\Delta C_t)^2, (\Delta^2 C_t)^2)$$

given C_{-1} , C_{-2} and subject to the constraints:

$$(2.1) \quad C_t + K_t = Y_t - g(K_{t-1}) + K_{t-1}, \quad t = 1, 2, 3, \dots$$

given K_0 , with the notation:

C_t : Level of consumption at time t .

K_t : Amount of commodity saved at time t .

Y_t : Random endowment given to the economy at time t .

$g(\cdot)$: Storage cost as a function of last period's savings.

Δ, Δ^2 : First and second order difference operators.

β : Discount factor, constant between zero and one.

The constraints (2.1) state that current consumption and savings add up to the current endowment plus last period's savings, net of storage costs. The dependence of U on $(\Delta C_t)^2$ and $(\Delta^2 C_t)^2$ is supposed to be negative for all t . The storage cost function is assumed to take the form:

$$(2.2) \quad g(K_{t-1}) = \frac{\theta}{2} (K_{t-1} - \tilde{K})^2$$

where \tilde{K} is some level of storage that would produce zero storage costs. The value of \tilde{K} is treated parametrically.

An argument for using this cost of storage function can be found in a now classical work by Brennan (2), where he goes into a detailed equilibrium theory of commodities being held as inventories. The appropriately computed cost of storage is composed of:

- a) The total outlay on physical storage: Rent for storage space, interest, insurance, handling charges.
- b) Plus a risk aversion factor.
- c) Minus the convenience yield.

As the quantity of stock increases, so does the total outlay. It may increase at a constant rate for a while, and at an increasing rate afterwards. We should also expect the total risk aversion component of the cost to be an

increasing function of stocks. If a small quantity of stocks are being held, then the risk involved because of a fall in prices, say is also small. The convenience yield on stocks, as introduced by N. Kaldor (11) is attributed to the advantage in terms of less delays and lower costs of being able to keep regular customers satisfied, or being able to take advantage of a rise in demand and prices without resorting to a revision of the production schedule. The smaller the level of stocks on hand, the greater will be the convenience yield of an additional unit, being zero for a large enough level of stocks. Hence, the convenience yield is supposed to be increasing with decreasing returns, and then almost constant or slowly decreasing. The cost of storage as an aggregate of the three components a) - c) above would assume an U-shape. I keep that shape for the storage cost function but restrict my consideration to the simpler, symmetric case.

Savings of K_t units of commodity today become $K_t - \frac{\theta}{2} (K_t - \tilde{K})^2$ units of commodity tomorrow. Hence the marginal rate of return on savings is positive so long as $1 - \theta (K_t - \tilde{K}) \geq 0$, which happens whenever the level of savings is no greater than $\tilde{K} + \frac{1}{\theta}$. The relationship between today's savings and tomorrow's receipts is then:

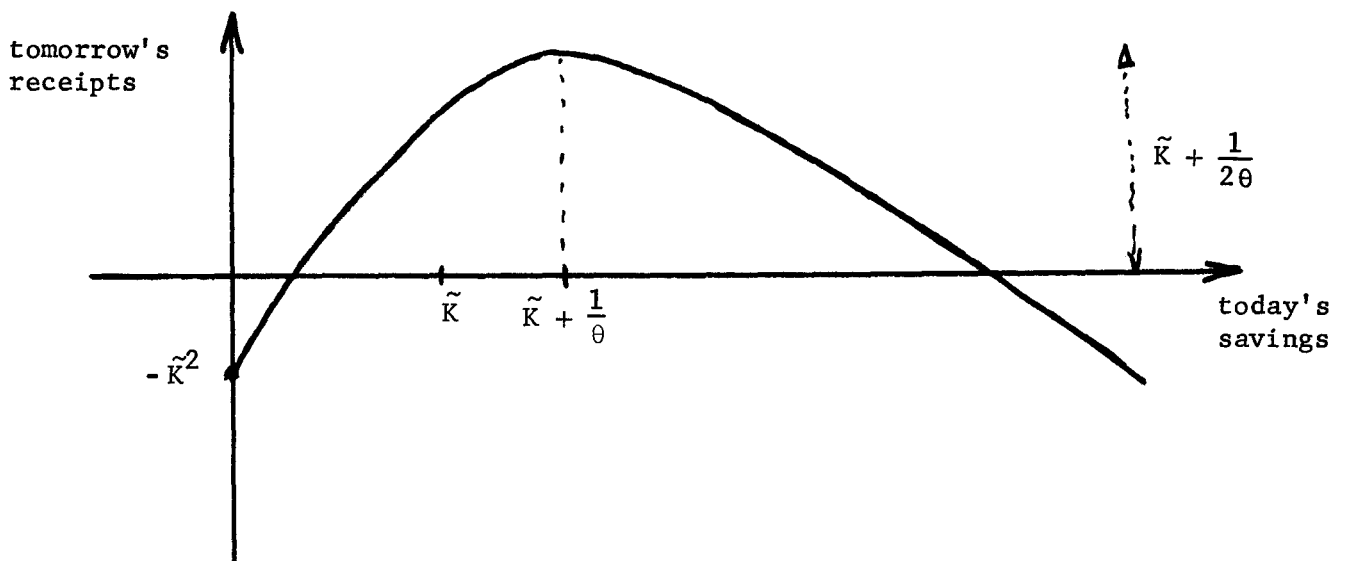

It is easy to see the role played by consumers' savings in this model. Consumers smooth out their individual consumption paths by saving when income is high. That produces some storage costs, but it decreases the penalties in utility. By saving, consumers will reach a smooth consumption path whose expected value lies below the expected value for the path they could get by keeping a constant level of savings \tilde{K} each period. This will lead them to a consumption level in the region of positive marginal utility. No consuming their whole endowment Y_t , their instantaneous utility is not at its maximum possible value, but since changes in consumption will be smaller than with a constant level of savings, the penalties in utility will also be smaller, compensating the decrease in the level of consumption.

In Appendix A, I show that the following condition is necessary for the optimality of the processes C_t and K_t :

$$(2.3) \quad 1 - \theta(K_t - \tilde{K}) = \frac{E_t \partial \tilde{U} / \partial C_t}{E_t \partial \tilde{U} / \partial C_{t+1}}$$

where E_t denotes the expectation conditional on the information set at time t , Ω_t , which is supposed to contain the variables $(C_{t-i}, K_{t-i}, Y_{t-i}, i \geq 0)$, showing that consumers decide to invest and consume up to the point where the marginal rate of return on investment and the marginal rate of time preference are equal. Given an income process, then (2.3) together with the constraints (2.1) could be used to obtain the optimal processes for consumption and savings, starting from some initial conditions.

This planner problem summarizes all what is taking place in this economy. However, under this formulation, the problem is not very useful for the purpose I described in the Introduction. In particular, I have not described a financial sector that could provide us with a meaningful interest rate variable. There is another formulation of the same problem which can

give us a richer set of variables. That representation consists essentially in decentralizing the decision making process as follows: Let us assume that there is a single firm in the economy which is owned by all consumers and is financed by issuing bonds and equities. The sole commodity in the economy is now used as both consumption and capital good. The firm receives each period the stochastic endowment we mentioned above and uses part of it to finance purchases of capital from consumers, distributing what is left equally among them. One part of the capital the firm purchases each period is financed by issuing bonds, which pay interest returns at a rate r_t . The firm takes the interest rate as given, and chooses at each time t how much capital to buy, how many bonds to issue and how much earnings to distribute among its shareholders. The objective of the firm is to maximize the present value of the stream of future payments to shareholders, discounted with the interest rate. Thus, the firm solves the problem:

$$\text{Max } E_0 \sum_{t=0}^{\infty} \left(\prod_{s=0}^{t-1} (1+r_s)^{-1} \right) Y_t^*$$

subject to the constraints:

$$(2.4) \quad Y_t + B_t = Y_t^* + \frac{\theta}{2} (K_{t-1} - \tilde{K})^2 + K_t - K_{t-1} + (1+r_{t-1}) B_{t-1}$$

given B_{-1} , K_{-1} , and with the notation:

Y_t^* : Payments to shareholders at time t .

B_t : Amount of bonds issued at time t .

r_t : Interest rate to be paid at time $t+1$ on bonds issued at time t .

K_t : Capital stock owned by the firm at time t .

Y_t : Stochastic endowment given to the firm at time t .

The budget constraint (2.4) shows how the firm's receipts, which are

equal to the random endowment plus the borrowings made from consumers, are spent in storage costs, purchases of capital, interest payments, and payments to shareholders. The constraint also shows that in order to finance its capital purchases, the firm has available different values for the variables B_t and Y_t^* . That means that to finance a given addition of capital stock, the firm can decide to issue less bonds, i.e., borrow less, and retain more earnings, i.e., decrease Y_t^* , or alternatively, issue more bonds and distribute more earnings.

It can be shown that the following optimality condition must hold:

$$(2.5) \quad 1 + r_t = 1 - \theta (K_t - \tilde{K})$$

which is the demand for storage of capital goods. Let us now see how the firm's decision about how to finance its capital affects its value. Using (2.5) into the firm's constraint (2.4), we get:

$$(2.6) \quad Y_t^* = Y_t + B_t - (1 + r_{t-1}) B_{t-1} + \frac{r_t - r_{t-1}}{\theta} - \frac{r_{t-1}^2}{2\theta}$$

and therefore, the expected present value of the firm can be written:

$$E_0 \sum_{t=1}^{\infty} \left(\prod_{s=0}^{t-1} (1 + r_s)^{-1} \right) Y_t^* =$$

$$E_0 \sum_{t=1}^{\infty} \left(\prod_{s=0}^{t-1} (1 + r_s)^{-1} \right) \left(Y_t + B_t - (1 + r_{t-1}) B_{t-1} + \frac{r_t - r_{t-1}}{\theta} - \frac{r_{t-1}^2}{2\theta} \right)$$

and it is easy to check how the terms involving bonds cancel out. The only value remaining is B_0 which is taken as an initial condition in the optimization problem. That means that the financing decisions of the firm, and more specifically the equity-debt ratio adopted does not affect the value of the firm. This is the statement of the Modigliani-Miller theorem for this economy.

We further assume that the typical consumer behaves as an interest rate taker -- as we assumed for the firm -- and maximizes his expected discounted utility subject to the budget constraint which states that current consumption and loans to the firm add up to current payments received as shareholders plus interest returns. At each point in time, the consumer takes both Y_t^* and r_t as given and decides how much to consume and how much to loan to the firm. These loans may be negative, and in any case, he believes he is allowed to either borrow from or loan to the firm as much as he wishes at the market prevailing rate of interest. To make these decisions, he solves the problem:

$$\text{Max } E_0 \tilde{U} = \text{Max } E_0 \sum_{t=0}^{\infty} \beta^t U(C_t, (\Delta C_t)^2, (\Delta^2 C_t)^2), \quad 0 < \beta < 1$$

subject to the constraints:

$$(2.7) \quad C_t + B_t = Y_t^* + (1 + r_{t-1}) B_{t-1}, \quad t = 1, 2, 3, \dots$$

given r_{-1} , B_{-1} , C_{-1} , C_{-2} , and with the notation:

C_t : Current consumption.

B_t : Loans made to the firm at time t .

r_{t-1} : Interest rate to be paid at time t on the loans made at time $t-1$.

Y_t^* : Payments made by the firm to the consumer at time t .

To get as necessary conditions for the optimality of the processes

$\{C_t\}_{t=0}^{\infty}$ and $\{B_t\}_{t=0}^{\infty}$:

$$(2.8) \quad 1 + r_t = \frac{E_t \partial \tilde{U} / \partial C_t}{E_t \partial \tilde{U} / \partial C_{t+1}}$$

explaining that along the optimal path, consumption is chosen so as to make the marginal rate of time preference equal to one plus the given interest rate.

Notice that the firm's financing decision affects consumers' budget constraint through the chosen value of Y_t^* . However, the way how consumers' decisions will be affected by the different possible settings of Y_t^* is consistent with the firm's decision: If at time t the firm would decide to pay shareholders an amount smaller than Y_t^* , then consumption would not change as we can see in (2.8). Then, loans to the firm would have to decrease by the same decrease in Y_t^* . This is clearly consistent with the fact that the firm would be in that event distributing less earnings and borrowing less.

The economy is in equilibrium if at each time t , the following two conditions are satisfied:

- i) The amount of debt that the firm finances by issuing bonds is equal to consumers' loans, and
- ii) The interest rate that both consumers and the firm take as given when solving their respective optimization problems is the same.

The equilibrium value of the interest rate is determined by the interaction of consumers' demand for the commodity and the firm's demand for capital stock, (2.8) and (2.5), and hence we have in equilibrium:

$$(2.9) \quad \frac{E_t \partial U / \partial C_t}{E_t \partial \bar{U} / \partial C_{t+1}} = 1 + r_t = 1 - \theta (K_t - \bar{K})$$

so that the marginal rate of consumers' time preference and the firm's marginal rate of return on capital are both equal to the equilibrium rate of interest plus one. This condition is the same one that would prevail in this model if rather than going through this decentralized decision process we had just assumed the existence of a perfect market (i.e., without limitations on quantities traded) for borrowing and lending capital. The whole system (2.9) also shows the peculiarities of our approach: Now we cannot take the current value of the interest rate as being a given constant which together with the

history of consumption determines our consumption decisions. The interest rate is no longer constant but rather is determined in equilibrium as another endogenous variable. The equilibrium condition (2.9) reproduces (2.3), the equality between the marginal rate of return on savings and the marginal rate of time preferences that we obtained as optimality condition for the original problem.

Along this research, I specialize the single period utility function to be of the form:

$$(2.10) \quad U(C_t, (\Delta C_t)^2, (\Delta^2 C_t)^2) = C_t - \frac{n}{2} C_t^2 - \frac{b}{2} (C_t - C_{t-1})^2 - \frac{d}{2} (C_t - 2C_{t-1} + C_{t-2})^2$$

which, as I advanced in the Introduction, penalizes in a symmetric way upwards and downwards changes in the level of consumption. At some points I will assume zero values for the coefficients b and d , which leaves us with a time separable utility function, and at some other points I will append the dependence of the utility on the level of real balances being held at the end of each period. With the specification (2.10), the optimality conditions (2.9) become:

$$(2.11) \quad 1 + r_t = \frac{1}{\beta} \cdot \frac{1 - d\beta^2 E_t C_{t+2} + \beta A E_t C_{t+1} - B C_t + A C_{t+1} - d C_{t-2}}{1 - d\beta^2 E_t C_{t+3} + \beta A E_t C_{t+2} - B E_t C_{t+1} + A C_t - d C_{t-1}}$$

where:

$$A = b + 2d(1 + \beta)$$

$$B = n + b + d + b\beta + 4d\beta + d\beta^2$$

Similarly to any permanent income model of consumption, the equilibrium condition (2.11) clearly shows how in this model, households look into the future when deciding the optimal values of current consumption and savings. The equilibrium value of the interest rate can be thought of as being the sufficient statistic that summarizes all the information about future developments in the economy which is relevant for the consumer to make his current

period's optimal decisions.

Although the utility function written as in (2.10) is consistent with the ideas on consumers' behavior suggested in the Introduction, it is worthwhile for future discussions to show that there exists a one-to-one mapping between the parameter space (n, b, d) at (2.10) and the parameter space in the family of utility functions:

$$(2.12) \quad U(C_t, C_{t-1}, C_{t-2}) = C_t - \frac{\alpha_0}{2} C_t^2 - \alpha_1 C_t C_{t-1} - \alpha_2 C_t C_{t-2}$$

so that a given vector (n, b, d) and its image $(\alpha_0, \alpha_1, \alpha_2)$ render the same first order necessary conditions in the optimization problem. That mapping is described by the system of equations:

$$\begin{aligned} \alpha_2 &= d \\ \alpha_1 &= -b - 2d - 2d\beta = -A \\ \alpha_0 &= n + b + d + \beta b + 4d\beta + d\beta^2 = B \end{aligned}$$

Notice that this mapping is conditional on a given value for the discount factor β . We will see in the chapter dedicated to the estimation of this model, that actual data suggest a positive value for both n and d , but a negative value for the coefficient in the first order differences in consumption. This result seems contradictory at first glance, but I will explain there how that estimated value preserves the concavity of the aggregated utility function. Moreover, for any of the different estimates I will present, the coefficients α_0 , α_1 and α_2 in (2.12) are always positive.

Now, given an income process Y_t , the equilibrium of the model is a vector stochastic process: $[C_t, K_t, r_t, Y_t^*, B_t]$, such that conditions (2.1), (2.4) and (2.9) are satisfied. As one can see, the equity-debt ratio chosen by the firm does not affect the equilibrium processes C_t , r_t and K_t . This implies an indeterminacy in the solution of the model, which can also be

observed in the fact that (2.1), (2.4) and (2.9) give us 4 equations from which to determine 5 variables. We would further need to add a given equity-debt ratio to be able to get the solution to the problem. Luckily enough, we do not need to completely solve the model in order to address the issues I mentioned in the Introduction. As a matter of fact, once a certain stochastic structure has been assumed for the income process Y_t , like:

$$(2.13) \quad M(L) Y_t = N(L) u_t$$

with $M(\cdot)$ and $N(\cdot)$ being lag polynomials and u_t a white noise process, then (2.9) and the economy's budget constraint (2.1), -which results from (2.7) and (2.4) -, can be used to get an "optimal" realization for the vector stochastic process C_t, K_t, r_t, Y_t , starting from some initial values (C_{-2}, C_{-1}, K_{-1}). These initial values will just affect the first order moments of the generated time series. Since our main interest is to study the patterns of correlations and cross-correlations among the series for C_t, K_t, r_t , and Y_t , then the choice of the initial values is irrelevant to us. That choice is, however, useful to generate data that look like actual economic time series. Unfortunately, the high degree of non-linearity involved in (2.9) makes very difficult finding a direct solution to (2.1) and (2.9). A more feasible way of solving the model is as follows: Assume some stochastic process for C_t of the form:

$$(2.14) \quad A(L) C_t = B(L) e_t,$$

where e_t is a white noise process. Then, one can compute the conditional expectations in (2.11) using the Wiener-Kolmogorov formula. Equations (2.1) and (2.9) would then give us paths for K_t, r_t and Y_t . We may or may not be able to recover the closed form corresponding to the stochastic structure for the Y_t process. What we can say is that we have generated a realization for

a Y_t process whose stochastic structure we have not identified but which is such that when given to the economic agents, it produces as optimal processes for C_t , K_t and r_t the structure (2.14) from which we started and the corresponding processes for K_t and r_t obtained by using (2.14) in (2.9).

3. SIMULATION METHODOLOGY

In these simulations, I have followed the procedure described at the end of the previous section. First, a process of the form (2.14) is chosen for consumption. Then (2.1) and (2.9) are used to generate data for K_t , r_t and Y_t . It is well known that in the continuous case, a white noise lacks first order derivative. By analogy, I will work with a consumption process that admits an autoregressive representation of an order greater than the maximum order of the differences involved in the model. More specifically, I will consider a process of the form:

$$(3.1) \quad (1 - aL)^3 C_t = e_t$$

with e_t independent and identically distributed $N(m_e, \sigma_e^2)$.

It is not hard to show that under (3.1), we have:

$$(3.2) \quad C_t = \sum_{j=0}^{\infty} \binom{j+2}{j} (aL)^j e_t = \sum_{j=0}^{\infty} b_j e_{t-j} = B(L) e_t$$

and that its covariance generating function is given by:

$$g_c(z) = \sigma_e^2 B(z) A(z^{-1}) = \\ \sigma_e^2 (s_1 + s_2 az + s_3 a^2 z^2 + s_4 a^3 z^3 + \dots) (s_1 + s_2 az^{-1} + s_3 a^2 z^{-2} + s_4 a^3 z^{-3} + \dots)$$

which produces:

- i) Variance $(C_t) = \sigma_e^2 (s_1^2 + s_2^2 a^2 + s_3^2 a^4 + s_4^2 a^6 + s_5^2 a^8 + \dots)$
- ii) Cov $(C_t, C_{t-1}) = \sigma_e^2 (s_1 s_2 a + s_2 s_3 a^3 + s_3 s_4 a^5 + s_4 s_5 a^7 + \dots)$
- iii) Cov $(C_t, C_{t-2}) = \sigma_e^2 (s_1 s_3 a^2 + s_2 s_4 a^4 + s_3 s_5 a^6 + s_4 s_6 a^8 + \dots)$

where s_j denotes the sum of the first j integers and is therefore given by:

$$s_j = \frac{j(j+1)}{2}$$

The following table summarizes these statistics for some values of a:

a	Var(C_t)	Cov(C_t, C_{t-1})	Cov(C_t, C_{t-2})
.70	92.75	90.69	85.21
.80	656.50	651.94	635.07
.90	19773.44	19736.69	19627.65
.95	615654.61	615384.35	614575.70

where all elements in the table must be multiplied by σ_e^2 .

The choice of the consumption process is common to all the simulations that follow, and is given by (3.1), with $a = .90$, $m_e = 1.7$, $\sigma_e^2 = .01$. This produces an expected value for C_t of 1700 and a variance of 197.73. The parameter vector (β, n, b, d, θ) is chosen so as to get values for consumption moving in the region where the marginal utility is positive. We should expect that to happen if the consumption path is optimizing consumers' utility. Consumption itself, and any linear combination of consumption values at different points in time is normally distributed, and with probability .9987, it will take values in the interval $m_c \pm 3\sigma_c$ where m_c and σ_c denote respectively, the mean and standard deviation of consumption. If we want to get a positive marginal utility with very large probability, we have to pick values for the parameters which will ensure that to be the case even when consumption takes a value as large as $m_c + 3\sigma_c$ while Δc and $\Delta^2 c$ take values like $m_{\Delta c} \pm 3\sigma_{\Delta c}$, $m_{\Delta^2 c} \pm 3\sigma_{\Delta^2 c}$.

Thus we want:

$$1 - n(m_c + 3\sigma_c) > 9 \frac{b}{2} \sigma_{\Delta c}^2 - 9 \frac{d}{2} \sigma_{\Delta^2 c}^2$$

If we start by choosing a value \hat{n} for n so that:

$$n < \hat{n} = \frac{1}{m_c + 3\sigma_c}$$

and if we call:

$$M = 1 - n(m_c + 3\sigma_c)$$

then, if we take in addition both penalties in the utility function to be of similar value, then we will choose b and d so that:

$$9 \frac{b}{2} \sigma_{\Delta c}^2 \approx 9 \frac{d}{2} \sigma_{\Delta^2 c}^2 < \frac{M}{2}$$

Since the standard deviation of consumption is 14.06, then:

$$\frac{1}{m_c + 3 \sigma_c} = \frac{1}{1742.2} = .57 \cdot 10^{-3}$$

so that an acceptable value for n would be $n = .40 \cdot 10^{-3}$. In that case, we have: $M = .30$, and since:

$$\sigma_{\Delta c}^2 = 2 \sigma_c^2 - 2 \text{Cov}(C_t, C_{t-1}) = 73.4 \sigma_e^2$$

$$\sigma_{\Delta^2 c}^2 = 6 \sigma_c^2 - 8 \text{Cov}(C_t, C_{t-1}) - 2 \text{Cov}(C_t, C_{t-2}) \approx 2 \sigma_e^2$$

then,

$$\frac{9}{2} b (73.04) (.01) < \frac{M}{2} \Rightarrow b < .45 \cdot 10^{-1}$$

$$\frac{9}{2} d 2(.01) < \frac{M}{2} \Rightarrow d < 1.666$$

Once we have chosen values for the vector $(\beta, n, d, b, \theta, \sigma_e^2, a)$ as shown in Table 0, monthly time series data were generated for the period (60,1)-(84,12) for the variables C_t, r_t, K_t and Y_t . The interest rate was generated in "per units" as it is implied from the model. Quarterly averages were taken for all the variables. Then, leaving aside the first 28 quarters, the remaining 70 observations were used to compute:

- i) The sample statistics, as shown in Table 1.
- ii) All cross-correlations between each two variables, in Tables 3-6.
- iii) Regressions of consumption and output on a number of leads and lags of the interest rate, as shown in Tables 7-8.
- iv) A bivariate vector autoregression with 4 lags was estimated for logs of GNP and the interest rate. The relationship between these two variables, - whether it reflects feedback of not - (tested using Sims'

theorems in (22)), appears in Table 9. The covariance matrices for the residuals are given in Table 2. The two sets of impulse responses corresponding to the two possible orthogonalizations were obtained. However, since the empirical regularity in which I am interested concerns the response of output to a shock on the interest rate, that is the only response which is shown in Figures 1-8. Finally, some autocorrelation functions for consumption and the interest rate are shown in Table 9, as well as the value of the objective function for different runs.

Comments on the Results

Because of the smoothness of the consumption process, and provided that the penalty coefficients are not too large, then we should expect an interest rate moving around $\beta^{-1} - 1$. Among the set of parameter vectors in Table 0, there are just two different values of β , namely .95 and .90, and I correspondingly obtained sample expectations for the interest rate around $((.95)^{-1} - 1) \cdot 100 = 5.25$, and $((.90)^{-1} - 1) \cdot 100 = 11.11$, as can be seen in Table 1. The variable labelled "INVEN", in these Tables is $1 - \theta(K_t - K)$, and a fixed chosen value of $\theta = .001$ together with the equilibrium conditions (2.9) imply that the sample mean and variance for INVEN are 10 and 100 times those for the interest rate, respectively. Both sets of statistics are presented though, in case the reader wants to use capital stock rather than the interest rate to establish some comparisons between variables. For the same reason, the contemporaneous correlation between these two variables is -1.0 (see Table 1) and their cross-correlation function is symmetric.

By comparison between simulations 1 and 2 on the one hand, and simulations 3.a, 3.b and 3.c on the other, we can see that the effect of changing the discount factor from .95 to .90 is a change in the mean of

the interest rate as above mentioned plus a slight increase in the means of consumption and GNP, but no significant effect on the impulse responses.

To check whether alternative conventions about what should be called GNP in this economy might drastically affect the results, simulation 4 repeats the parametrization of simultaneous 3.a - 3.c but it excludes storage costs as a component of output, with no significant change in the results.

With a chosen value of $n = .0005$, then our previous analysis suggests values for the other two coefficients in the utility function of up to $b = .0196$ and $d = .72$. Simulation 5 shows that these values can be surpassed while maintaining the nature of the results. However, with the values for the penalty coefficients as in simulation 5, then a larger weight is given to the ratio in (2.11) when computing the equilibrium value of the interest rate. This should produce larger variations in these equilibrium values. One can check in Table 1 that the sample variance of the interest rate was multiplied by a factor of almost 5 in this case. The same comment applies to simulations 6.a and 6.b. For a value of $n = .0002$, the coefficients b and d should take values of up to .10 and 3.6, which are roughly the ones used in simulation 6.a. To run simulation 6.b, these values were approximately doubled, to get the sample variance of the interest rate multiplied by a factor of about 4.

Simulations 7.a and 7.b and 8 use parametrizations which had already been used in previous simulations, but this time the time series averages are taken over 6 successive observations. We can see in Figure 8 that the pattern of the impulse responses is now rather different. Simulation 8 produced the same shape of responses but with a deeper trough.

The following empirical observations are consistent across these

simulations:

1. The cross-correlations between GNP and the interest rate are negative at all leads and lags, the greater correlation running from the past of the interest rate to current and future GNP. This is consistent with our intuition that the financial markets might anticipate future developments in the economy's real sector. (Remember that I do not concede any "causality" meaning to this observation, but just an "informative" one). This is also consistent with the fact that the null hypothesis of the group of four lags of the interest rate being zero in the regressions of GNP and consumption in Tables 7 - 8 was always rejected.
2. The contemporaneous correlation between GNP and the interest rate is negative in all the simulations. This happens because in this economy, consumers are always saving below K. That produces a positive real interest rate. If the typical consumer increases his savings today, that will increase next period's output and decrease the marginal return on savings and hence the interest rate. If output displays some positive autocorrelation, then we would get negative contemporaneous correlation between output and the interest rate.
3. The cross-correlations between consumption and the interest rate (see Table 5), present almost the same pattern than the correlation between GNP and the interest rate. The reason is the strong positive correlation between consumption and GNP that extends to at least three leads and lags as can be seen in Table 6. This agrees with observations in actual data.

The interpretation of these results can run as follows: interest rates anticipate future supply shocks. This is reflected in the influence of the rate on GNP running from the past of the interest rate to current and future output. Now, suppose that a future period of low productivity is detected. The interest rate will start rising today. This produces a decrease in

current investment. Furthermore, tomorrow's consumption has been made cheaper relative to consumption today, and therefore, current consumption also comes down. While the downward movement in investment can be expected to extend just through next period, the downward movement in consumption will last at least 3 more periods. (This is because of the sample correlations obtained). There is some reason to believe that any interest rate movement will persist for a while, and that is the smoothness in the GNP process itself.

What is going to happen then is that a jump in the interest rate today anticipates a period of sluggish economic activity, reflected in a period of low investment, low consumption and low output. Troughs of GNP and consumption in economic fluctuations are coming together. In the case of a negative supply shock, common belief that the interest rate anticipates future GNP random shocks has the effect that the downward movement in consumption starts earlier than without the anticipation. That creates smaller changes in consumption when it is decreasing, and consequently, smaller penalties in utility. When the penalties are small enough, - presumably when we are close to the anticipated trough in GNP - , then the changes in consumption will start reversing sign, with penalties of similar value to the ones we got in the downward section. Savings will start recovering and the interest rate decreasing, some periods before consumption starts climbing up.

4. CONCLUSIONS

The focus of this paper has been to develop a framework by which to study the joint optimal consumption-investment decisions taken in a stochastic environment. The equilibrium model that has been presented shows how the interest rate is a stochastic process whose nature is determined by the consumers' joint optimal decisions. The goodness of fit of the model has been measured by its ability to reproduce the empirical observations of current research concerning the responses of output to an instantaneous, positive shock in the interest rate. The feature of this model that produces the delayed, negative response of output to that shock is the presence of disutilities created by changes in consumption. One should expect that this is not the only way to generate that pattern of responses. If we take the penalties out of the utility function and consider adjustment costs of investment - transaction costs of assets, for example - we might be able to get the same kind of response. Besides, this reformulation could conceivably produce the positive contemporaneous correlation between output and the interest rate that I have not obtained with this model.

The estimation technique that has been adopted is rather rudimentary: it reduces to an elementary grid search on the parameter space. Some other alternatives are available: One could use actual time series for some of the variables in the model and use the necessary conditions for optimality to generate data for the other variables. Then, we could choose as estimator of the parameter vector that point in the parameter space that minimizes some definition of distance between the generated and the actual time series for the second subset of variables. A different method would use actual time series for all the variables to estimate the parameters in the model. In this case, we would have to specify the expectations formation schemes for

the conditional expectations involved in the first order necessary conditions for optimality. In both cases, we could use the same criterion for goodness of fit that we have used in this paper.

In a more general class of models, one would like to consider money together with some other asset, and try to estimate a model that produces causal priority of the financial sector with respect to the rest of the economy, together with an apparent active role for money in explaining the real sector of that economy. We would also like that model to produce the empirical regularities that have been obtained with the simple model presented in this paper.

APPENDIX A

Consider the optimization problem:

$$(A.1) \quad \text{Max}_{\{C_t, K_t\}} E_0 \tilde{u}(\{C_t\}) = E_0 \sum_{t=0}^{\infty} \beta^t u(C_t, (\Delta C_t)^2, (\Delta^2 C_t)^2)$$

subject to:

$$(A.2) \quad C_t + K_t = Y_t + K_{t-1} - \frac{\theta}{2} (K_{t-1} - \tilde{K})^2$$

$$C_t \geq 0, K_t \geq 0, \quad t = 0, 1, 2, \dots$$

According to the techniques explained in Kushner (10), (11), there exists sequence $\{\lambda_t\}$ of random variables such that:

$$(A.3) \quad (E_t \tilde{u}_{C_t} - E_t \lambda_t) C_t = 0$$

$$(A.4) \quad [-E_t \lambda_t + E_t \lambda_{t+1} - \theta(K_t - \tilde{K}) E_t \lambda_{t+1}] K_t = 0$$

$$(A.5) \quad C_t + K_t = Y_t + K_{t-1} - \frac{\theta}{2} (K_{t-1} - \tilde{K})^2$$

where \tilde{u}_{C_t} denotes the partial derivative of \tilde{u} with respect to C_t . In this methodology, E_t denotes the operator expectation conditional on the sigma algebra F_t of subsets of Ω_t , a set which contains current and past decisions and states. Hence, the conditional expectation E_t of any current or past decision variable is that same variable. Using standard properties of the conditional expectation operator, we get from (A.3) that in the case when $C_{t+1} > 0$, then:

$$(A.6) \quad E_{t+1} \lambda_{t+1} = E_{t+1} \tilde{u}_{C_{t+1}} \quad \text{and}$$

$$(A.7) \quad E_t (E_{t+1} \lambda_{t+1}) = E_t \lambda_{t+1} = E_t \tilde{u}_{C_{t+1}}$$

and dividing through (A.4) by $E_t \lambda_t$, we get, again for an interior solution that:

$$(A.8) \quad E_t \tilde{u}_{C_t} = [1 - \theta(K_t - \tilde{K})] E_t \tilde{u}_{C_{t+1}}$$

In addition, the following transversality condition must be satisfied along an optimal path:

$$\lim_{T \rightarrow \infty} \beta^T E_T \lambda_T = \lim_{T \rightarrow \infty} \beta^T E_T \tilde{u}_{C_T} = 0.$$

FOOTNOTES

¹This result was obtained by Litterman and Weiss (14) using monthly time series for the period 1955-1971 to estimate a vector autoregressive model. They found the response of output to a shock in the interest rate to be positive and very small - about one-fifth of its standard deviation - for five months. Then that response comes down to minus one standard deviation for the 18 to 24 month period after the shock, and from then on, it has a very long and smooth recovery. In the period 1972-1980, the response is small and positive for two or three months. Then, it comes down to minus two standard deviations at 11-12 months after the shock, recovering smoothly and reaching zero at about 30 months after the initial shock. Working also with monthly data, Sims found that the decline starts after six months, reaching a minimum at about 20 months after the shock, and slowly recovering toward zero. Sims found this evidence not only for the U.S., but also for Germany, U.K. and France, and with data for the periods 1955-1979 and 1947-1978. Litterman and Weiss report the complementary observation that the real rate of interest seems to be governed only by its own past, thereby rejecting the hypothesis that monetary policy causally influences the rate. They also find that there is information in the level of the nominal rate that helps predicting output and which is not contained in past output or past and future expected real rates. They advance two possible explanations for this: a) A structuralist interpretation focusing on nonneutralities of various institutional nominal rigidities, and b) The argument that output is structurally exogenous with respect to money and prices, but new information is first reflected in expected information and interest rates.

REFERENCES

- (1) Ando, A. and Modigliani, F., "The Life Cycle Hypothesis of Savings: Aggregate Implications and Tests," American Economic Review, 53 (1), March, 1963, 55-84.
- (2) Brennan, M.J., "The Supply of Storage," American Economic Review, 48 (1), March, 1958, 50-72.
- (3) Fisher, I. The Theory of Interest. New York: Macmillan, 1930.
- (4) Friedman, M. A Theory of the Consumption Function. Princeton, NJ: Princeton University Press, 1957.
- (5) Green, J., "Temporary General Equilibrium in a Sequential Trading Model with Spot Futures Transactions," Econometrica, 41 (6), November, 1973, 1103-1123.
- (6) Hall, R.E., "Stochastic Implications of the Life Cycle-Permanent Income Hypothesis: Theory and Evidence," Journal of Political Economy, 86 (6), December, 1978, 971-987.
- (7) Hansen, L. and Sargent, T.J., "Formulating and Estimating Dynamic Linear Rational Expectations Models," Journal of Economic Dynamics and Control, 2 (1), February, 1980, 7-46.
- (8) Hart, O., "On the Existence of Equilibrium in a Securities Model," Journal of Economic Theory, 9 (3), November, 1974, 293-311.
- (9) Hirshleifer, J., "On the Theory of Optimal Investment Decisions," Journal of Political Economy, 66 (4), August, 1958, 329-352.
- (10) Jorgenson, D.W., "Capital Theory and Investment Behavior," American Economic Review, 53 (2), May, 1963, 247-259.
- (11) Kaldor, N., "Speculation and Economic Stability," Review of Economic Studies, 7 (1), October, 1939, 1-27.
- (12) Kushner, H.J., "On Stochastic Extreme Problems: Calculus," Journal of Mathematical Analysis and Applications, 10, 1965, 354-367.

- (13) Kushner, H.J., "On Stochastic Maximum Principle: Fixed Time of Control," Journal of Mathematical Analysis and Applications, 11, 1965, 78-92.
- (14) Litterman, R. and Weiss, L., "Money, Real Rate of Interest and Output," Working Paper #179, Federal Reserve Bank of Minneapolis, Sept, 1981.
- (15) Lucas, R.E., "Optimal Investment with Rational Expectations," in: Rational Expectations and Econometric Practice, R.E. Lucas and T.J. Sargent, eds., Minneapolis: University of Minnesota Press, 1981.
- (16) Lucas, R.E. and Prescott, E.C., "Investment under Uncertainty," Econometrica, 39 (5), September, 1971, 659-681.
- (17) Nickell, S.J. The Investment Decisions of Firms. Cambridge University Press, 1978.
- (18) Roll, R., "Assets, Money and Commodity Price Inflation under Uncertainty," Journal of Money, Credit and Banking, 5 (4), November, 1973, 903-923.
- (19) Sargent, T.J. Macroeconomic Theory. New York: Academic Press, 1979.
- (20) Sargent, T.J., "Estimation of Dynamic Labor Demand Schedules under Rational Expectations," Journal of Political Economy, 86 (6), December, 1978, 1009-1044.
- (21) Sims, C.A., "International Evidence on Monetary Factors in Macroeconomic Fluctuations," Discussion Paper No. 137, Department of Economics, University of Minnesota, Sept, 1980.
- (22) Sims, C.A., "Money, Income, and Causality," American Economic Review, 62 (4) September, 1972, 540-552.

Table 0.

	PARAMETER VALUES							Impulse Responses in:
	β	n	b	d	θ	σ_e^2	a	
SIM 1	.95	.0004	.03	1.11	.001	.01	.90	FIG 1
SIM 2	.95	.0004	.045	1.66	.001	.01	.90	FIG 1
SIM 3.a	.90	.0004	.030	1.11	.001	.01	.90	FIG 2
SIM 3.b	.90	.0004	.030	1.11	.001	.01	.90	FIG 2
SIM 3.c	.90	.0004	.030	1.11	.001	.01	.90	FIG 3
SIM 4	.90	.0004	.030	1.11	.001	.01	.90	FIG 4
SIM 5a & b	.90	.0005	.034	1.278	.001	.01	.90	FIG 5
SIM 6.a	.90	.0002	.10	4.0	.001	.01	.90	FIG 6
SIM 6.b	.90	.0002	.20	7.5	.001	.01	.90	FIG 7
SIM 7.a	.90	.0004	.045	1.66	.001	.01	.90	FIG 8
SIM 7.b	.90	.0004	.045	1.66	.001	.01	.90	FIG 8
SIM 8	.90	.0004	.030	1.11	.001	.01	.90	

Table 1

SAMPLE MOMENTS *

Expectation/Variance

	<u>GNP</u>		<u>RATE</u>		<u>CONS</u>		<u>INVEN</u>	
SIM 1	1696	115	5.34	.26	1695	123	-53	26
SIM 2	1697	128	5.36	.57	1696	134	-54	57
SIM 3.a	1706	187	11.13	.98	1700	201	-111	98
SIM 3.b	1711	76	10.84	.53	1706	84	-108	52
SIM 3.c	1705	272	11.0	1.60	1699	302	-111	161
SIM 4	1699	255	11.11	1.08	1699	258	-111	108
SIM 5.a	1705	260	.1087	.7 10 ⁻³	1699	257	-109	645
SIM 5.b	1708	321	10.28	5.2	1702	334	-103	515
SIM 6.a	1714	127	10.5	3.2	1708	117	-106	321
SIM 6.b	1708	192	10.2	12.7	1703	64	-102	1266
SIM 7.a	1706	90	11.0	1.21	1700	102	-110	121
SIM 7.b	1715	262	10.3	3.41	1710	304	-103	343
SIM 8	1703	370	11.2	.87	1696	406	-112	87

* Figures rounded to the closest digit.

COVARIANCE MATRICES

		RATE	GNP				
SIM 1	RATE	$.79 \cdot 10^{-1}$	$-.14 \cdot 10^{-3}$	SIM 2	.177	$-.325 \cdot 10^{-3}$	
	GNP	-.581	$.75 \cdot 10^{-6}$		-.60	$.163 \cdot 10^{-5}$	
SIM 3.a		.366	$-.70 \cdot 10^{-3}$	SIM 3.b	$.19 \cdot 10^{-4}$	$-.27 \cdot 10^{-5}$	
		-.64	$.32 \cdot 10^{-5}$		-.50	$.15 \cdot 10^{-5}$	
SIM 3.c		.4345	$-.95 \cdot 10^{-3}$	SIM 4	$.42 \cdot 10^{-4}$	$-.90 \cdot 10^{-5}$	
		-.76	$.36 \cdot 10^{-5}$		-.82	$.29 \cdot 10^{-5}$	
SIM 5.a		$.27 \cdot 10^{-3}$	$-.457 \cdot 10^{-4}$	SIM 5.b	$.20 \cdot 10^{-3}$	$-.33 \cdot 10^{-4}$	
		-.73	$.14 \cdot 10^{-4}$		-.60	$.157 \cdot 10^{-4}$	
SIM 6.a		$.15 \cdot 10^{-3}$	$-.19 \cdot 10^{-4}$	SIM 6.b	$.50 \cdot 10^{-3}$	$-.654 \cdot 10^{-4}$	
		-.54	$.84 \cdot 10^{-5}$		-.5550	$.277 \cdot 10^{-4}$	
SIM 7.a		$.693 \cdot 10^{-4}$	$-.171 \cdot 10^{-5}$	SIM 7.b	$.153 \cdot 10^{-3}$	$-.978 \cdot 10^{-5}$	
		-.182	$.128 \cdot 10^{-5}$		-.433	$.333 \cdot 10^{-5}$	
SIM 8		$.348 \cdot 10^{-4}$	$-.354 \cdot 10^{-5}$				
		-.571	$.110 \cdot 10^{-5}$				

Table 3

SAMPLE CROSS CORRELATION

	INVEN _t - RATE _{t-k}						
k:	-3	-2	-1	0	1	2	3
SIM 3.b			-.648	-1.0	-.648		
SIM 4			-.70	-1.0	-.70		
SIM 5.a			-.77	-1.0	-.77		
SIM 6.a	-.1976	-.3690	-.6810	-1.0	-.6810	-.3690	-.1976
SIM 6.b	.0680	-.2029	-.6426	-1.0	-.6426	-.2029	.0680
SIM 7.a	-.0962	-.1401	-.4210	-1.0	-.4210	-.1401	-.0962
SIM 7.b	-.1839	-.3811	-.6839	-1.0	-.6839	-.3811	-.1839
SIM 8	-.3878	-.4901	-.6841	-1.0	-.6841	-.4901	-.3878

Table 4

SAMPLE CROSS CORRELATION

$$\text{GNP}_t - \text{RATE}_{t-k}$$

k:	-3	-2	-1	0	1	2	3
SIM 3.b			-.112	-.198	-.248		
SIM 4			-.33	-.43	-.42		
SIM 5.a			-.40	-.46	-.36		
SIM 6.a	-.0851	-.1185	-.2737	-.2319	-.0486	-.2280	-.4483
SIM 6.b	.0096	-.0820	-.1404	.1381	.4856	.1543	-.1744
SIM 7.a	.1433	.0593	-.1162	-.2006	-.4401	-.6422	-.5722
SIM 7.b	-.1072	-.1803	-.3132	-.4334	-.5965	-.7786	-.7615
SIM 8	-.2773	-.3790	-.5034	-.6310	-.7260	-.8001	-.7518

Table 5

SAMPLE CROSS CORRELATION

$$\text{CONS}_t - \text{RATE}_{t-k}$$

k:	-3	-2	-1	0	1	2	3
SIM 4			-.26	-.39	-.50		
SIM 6.a	-.0047	-.0494	-.1523	-.3165	-.4428	-.5212	-.5487
SIM 6.b	.2761	.2877	.2202	.0508	-.2066	-.4180	-.5397
SIM 7.a	.1391	.0700	-.0456	-.3312	-.5994	-.6329	-.5282
SIM 7.b	-.0879	-.1572	-.2824	-.4838	-.7028	-.8000	-.7616
SIM 8	-.2715	-.3813	-.4913	-.6478	-.7659	-.7994	-.7562

Table 6

SAMPLE CROSS CORRELATION

$$\text{CONS}_t - \text{GNP}_{t-k}$$

k:	-3	-2	-1	0	1	2	3
SIM 4			.95	.98	.936		
SIM 6.a	.5289	.6406	.7221	.7747	.6455	.5435	.4296
SIM 6.b	.5129	.5470	.5181	.4057	.3133	.2790	.2351
SIM 7.a	.3891	.6499	.8692	.9530	.7634	.5523	.3124
SIM 7.b	.6798	.8254	.9407	.9751	.9022	.7819	.6409
SIM 8	.7542	.8625	.9474	.9954	.9365	.8474	.7401

Table 7

REGRESSIONS

1. Consumption on 4 leads and 4 lags of the interest rate:

	<u>R²</u>	<u>D.W.</u>	<u>Significance level</u>	H ₀ : <u>4 leads = 0</u>	<u>Significance level</u>
SIM 6.a	.45	.24	0	Accept	.9938
SIM 6.b	.37	.22	0		
SIM 7.a	.89	.6788	0	Inconclusive	.087
SIM 7.b	.90	.578	10 ⁻⁵	Accept	.45
SIM 8	.95	.665	.17 10 ⁻⁵	Accept	.23

2. Consumption on 8 lags of the interest rate:

	<u>R²</u>	<u>D.W.</u>	<u>Significance level</u>
SIM 6.a	.851	.26	0
SIM 6.b	.565	.138	0
SIM 7.a	.98	.276	0
SIM 7.b	.98	.2488	0
SIM 8	.99	.286	.26 10 ⁻⁶

** The null hypothesis H₀: 4 lags = 0 was always rejected.

* All regressions except in SIM 6.b, were run in differences with respect to the sample mean.

Table 8

REGRESSIONS

3. GNP on 4 leads and 4 lags of the interest rate:

	<u>R²</u>	<u>D.W.</u>	<u>Significance level</u>	<u>H₀: 4 leads = 0</u>	<u>Significance level</u>
SIM 6.a	.352	1.23	.0045	Reject	.024
SIM 6.b	.466	2.02	.49		
SIM 7.a	.85	1.23	.029	Accept	.50
SIM 7.b	.86	1.14	.049	Inconclusive	.085
SIM 8	.94	.8889	.29 10 ⁻²	Accept	.17

4. GNP on 8 lags of the interest rate:

	<u>R²</u>	<u>D.W.</u>	<u>Significance level</u>
SIM 6.a	.60	2.27	.28
SIM 6.b	.417	1.80	.16
SIM 7.a	.94	2.18	.072
SIM 7.b	.95	1.74	.22
SIM 8	.98	1.11	.59

* The null hypothesis H₀: 4 lags = 0 was always rejected

** Except in SIM 6.b, all regressions were run in differences to the sample mean.

Table 9

SAMPLE AUTOCORRELATION FUNCTIONS

K:	1	2	3	4	5	6	7	8	9	10
CONS	.8846	.6935	.5233	.3384	.2738	.1916	.1262	.0644	.0220	.0100
	.9419	.8155	.6608	.5092	.3796	.2795	.2059	.1542	.1213	.0967
RATE	.6743	.5317	.4635	.2769	.2316	.1712	.1885	.1916	.1929	.2222

RELATIONSHIP RATE - GNP:

SIM:	1	2	3.a	3.b	3.c	4	5.a	5.b	6.a	6.b	7.a	7.b	8
	F	F	F	F	F	Ex	Ex	Ex	Ex	F	F	Ex	Ex

F: Feedback RATE-GEP

Ex: Rate is exogenous with respect to GNP

UTILITY FUNCTION VALUES

SIM 7.a	7364.08
SIM 7.b	7356.63
SIM 8	7356.70

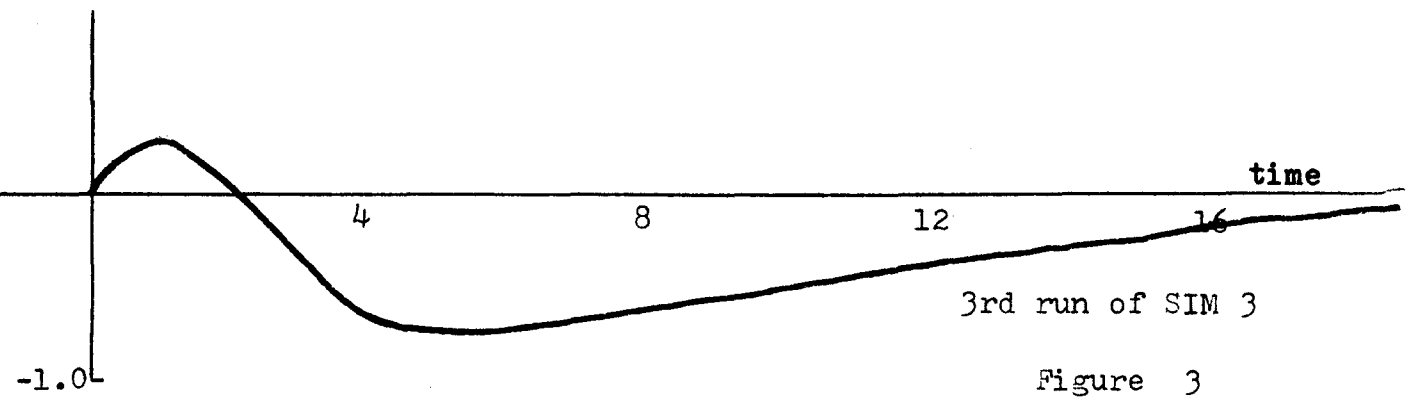
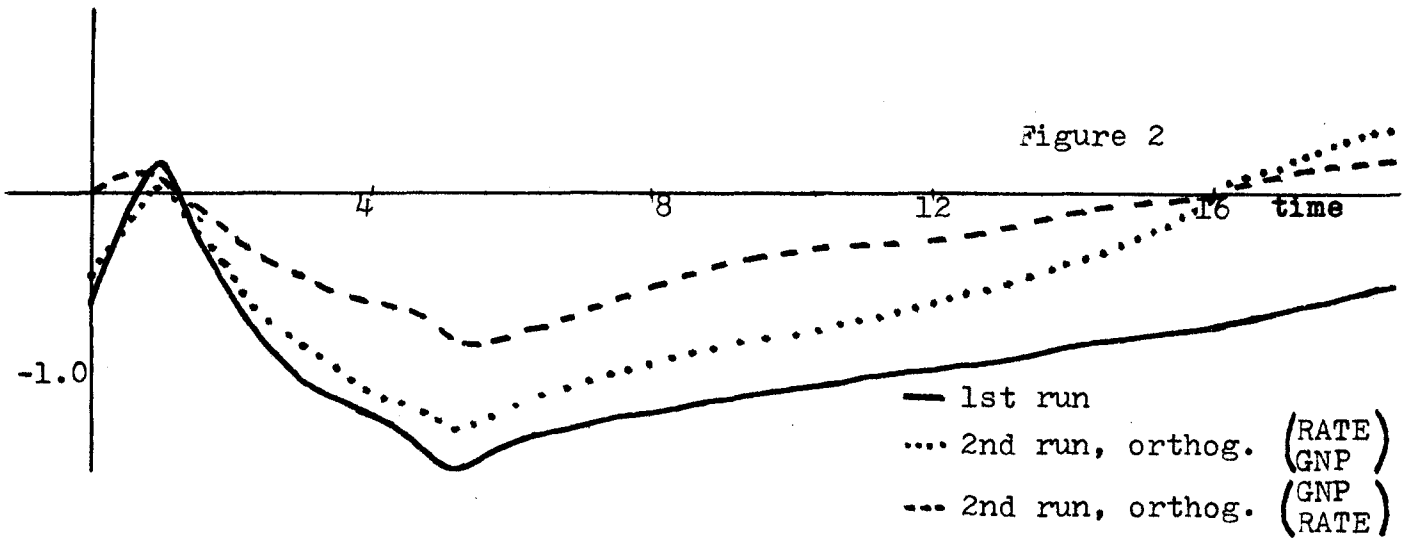
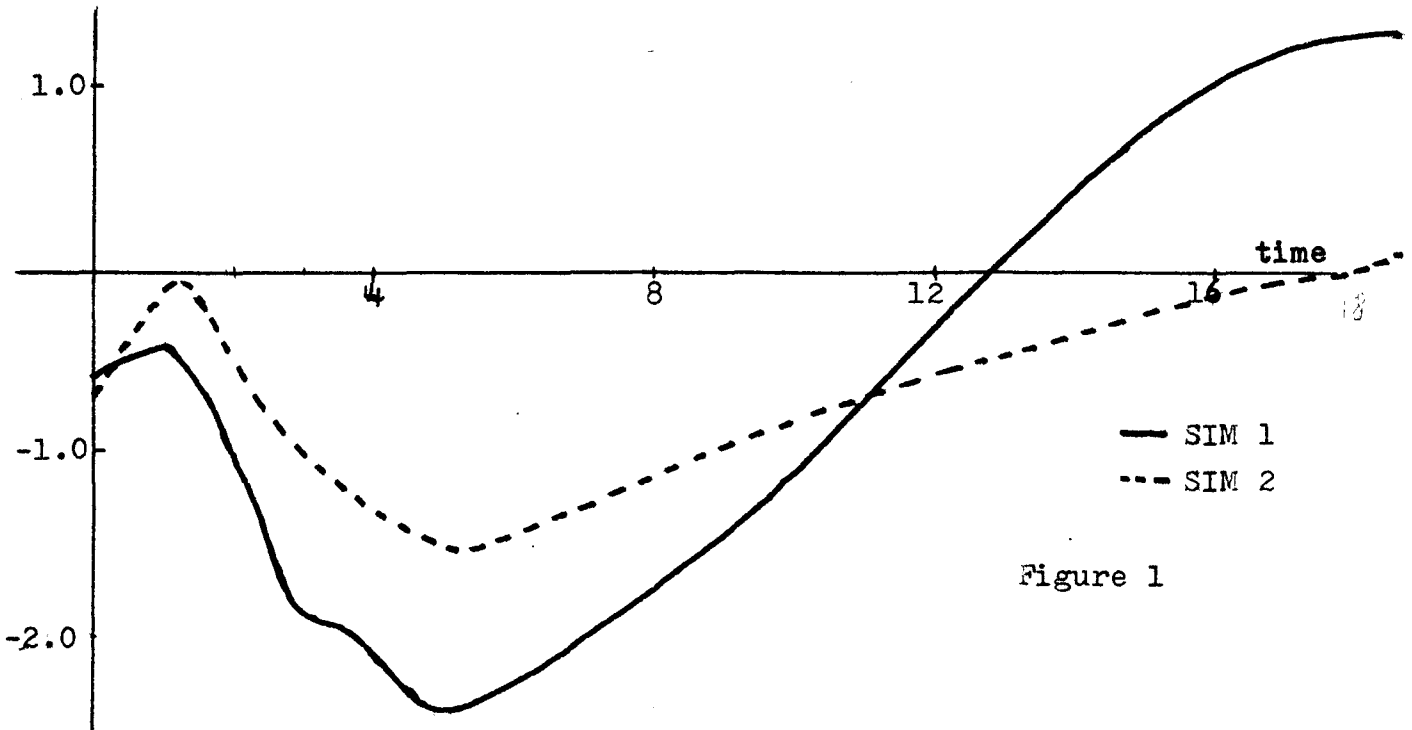

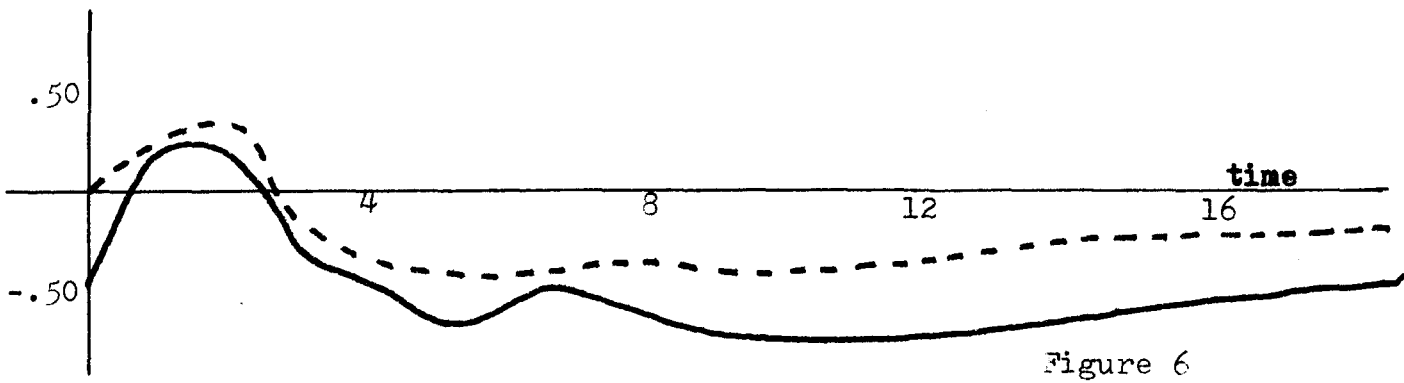
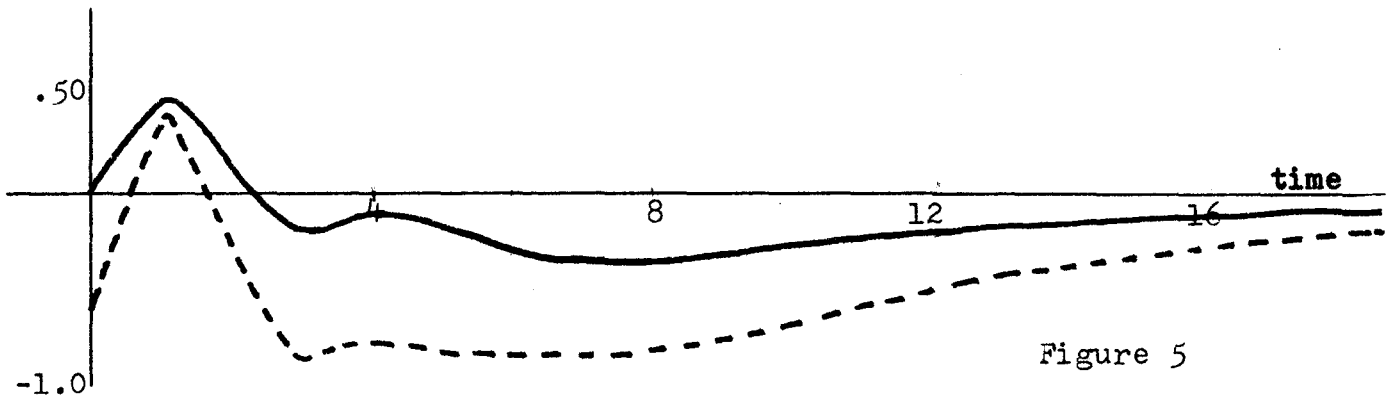
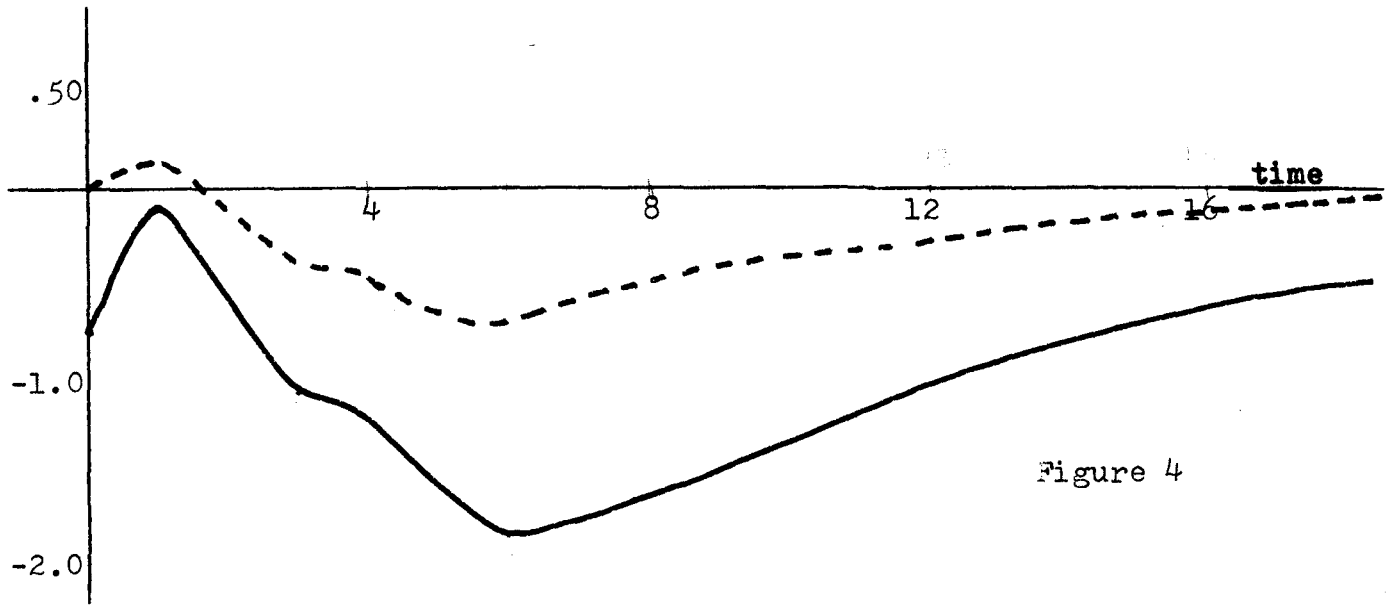

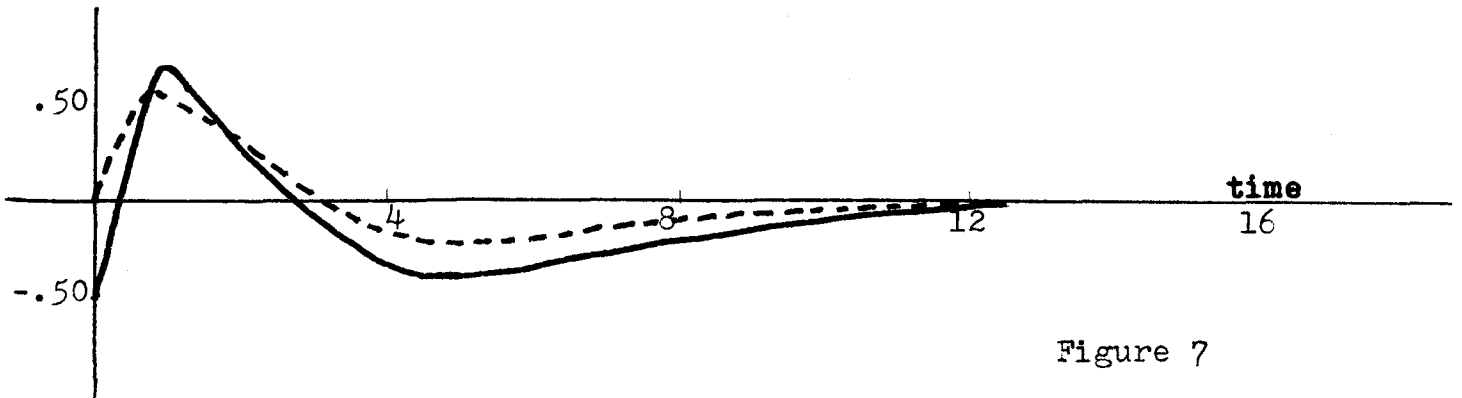

Figure 7

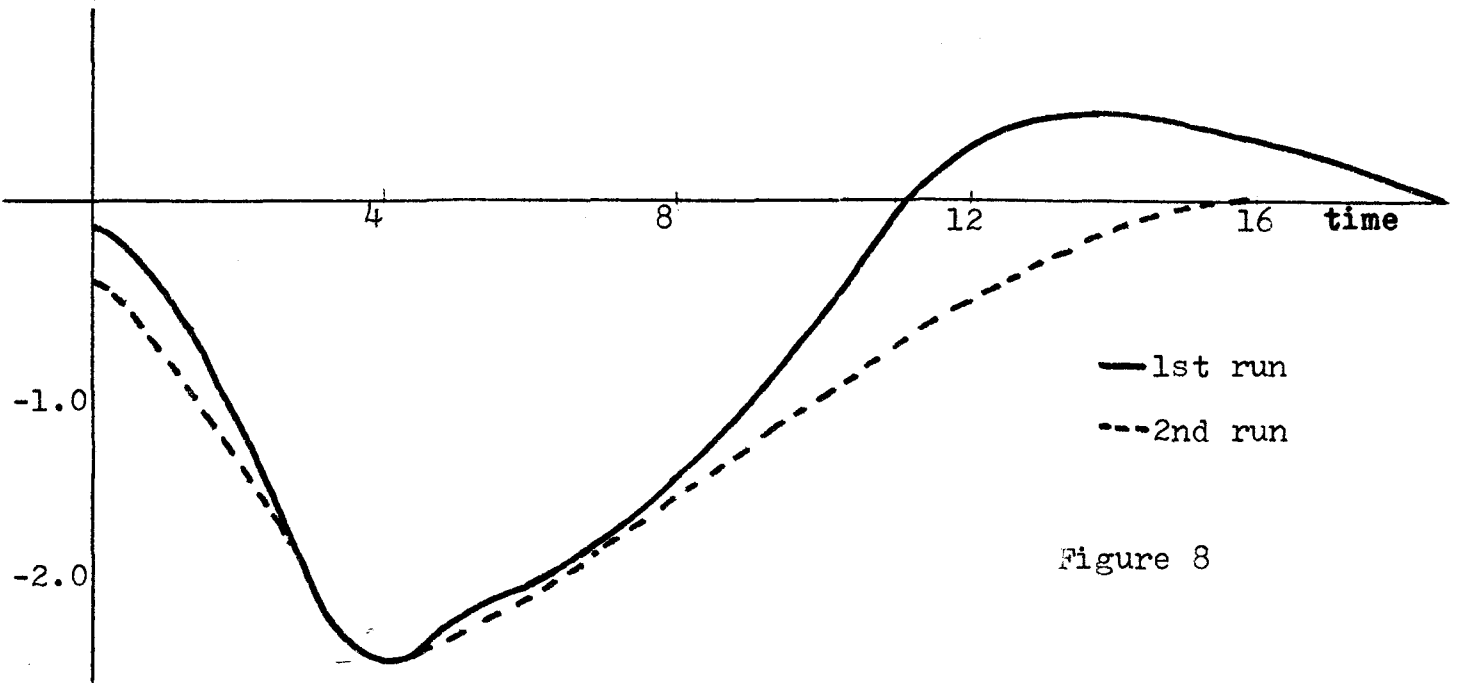

Figure 8