

4H-BU-2976-S
Revised 1990

MAGR
GOVS
MN
2500
FHBU-2976
1990
rev.



MINNESOTA EXTENSION SERVICE

UNIVERSITY OF MINNESOTA
4-H YOUTH DEVELOPMENT



Shooting Sports/ WILDLIFE

UNIVERSITY OF MINNESOTA
DOCUMENTS

JUN 08 2009

MAGRATH LIBRARY

Leader's Guide



This archival publication may not reflect current scientific knowledge or recommendations.
Current information available from University of Minnesota Extension: <http://www.extension.umn.edu>.

Shooting Sports / WILDLIFE

Leader's Guide



**4-H Youth Development
Minnesota Extension Service**

Acknowledgements

The Shooting Sports/Wildlife Project gratefully acknowledges the support of the Minnesota Deer Hunters Association, who provided funding for this project. The Minnesota Deer Hunters Association is dedicated to conserving the white-tail deer populations within the state of Minnesota.

Authors

Arlon E. Fritsche, Volunteer Leader,
Brown County

Jerry Hagen, Volunteer Leader,
Washington County

Michael Hamm, Safety Training Officer,
Department of Natural Resources

Larry Karels, Volunteer, Mille Lacs
County

James Kitts, Extension Specialist, Dept.
of Fisheries and Wildlife

Keith D. Kraai, Volunteer Leader, Scott
County

Gordy J. Krahn, Outdoor Writer

Mary Kroll, Extension Educator, 4-H
Youth Development

Thomas Kroll, Minnesota Department of
Natural Resources

John Kvasnicka, Executive Director,
Minnesota Deer Hunters Association

Patrick McGuire, Safety Training Officer,
Department of Natural Resources

Pamela McInnes, Extension Educator,
Department of Fisheries and Wildlife

Orv Meyer, Minnesota Department of
Natural Resources

Garth Miller, Volunteer Leader, Dakota
County

William F. Stevens, Volunteer Leader,
Anoka County

Thomas D. Zurcher, Extension Educator,
4-H Youth Development

Editor

Evelyn Anderson

Project Managers

Karen Burke, Gail Tischler

Illustration, Layout, Support

Larry Etkin, Delores Grochowski,
Cheryl Lieder

Introduction: 4-H Shooting Sports/Wildlife Leader's Guide

Welcome Project Leaders!

As a project leader you are critical to the success of the 4-H Shooting Sports/Wildlife program. The project meeting provides an exciting opportunity to help youth fulfill five basic needs: belonging, affection, achievement, independence, and new experiences. Young people also need to acquire subject matter knowledge, physical skills, decision-making abilities and wholesome attitudes toward themselves and others.

How successful you are will depend on your ability to relate to the individual needs of each member and adult, your willingness to allow members to be creative and learn from each other, and your ability to assume the role of a helper or coach rather than an up-front teacher.

The main goals of the Shooting Sports/Wildlife program are to:

- Help members develop leadership and citizenship qualities.
- Practice safe and responsible use of firearms.
- Develop and foster positive relationships with adults and family members.
- Develop self discipline, concentration, and new skills.
- Understand principles of wildlife management.
- Understand and practice the principles of conservation.

- Learn sportsmanship and ethical behavior.
- Appreciate shooting sports and wildlife management as a lifetime recreation or as a career.

This leader's guide is designed to help you plan project meetings that promote positive youth development. In addition to providing ideas for meeting activities, hints for getting started and planning a successful meeting are also included. You are encouraged to use additional audio visual and written materials. A suggested reference list is at the end of this book.

Getting Started

How do you start a Shooting Sports/Wildlife program in your community? There are generally three basic steps:

- **Develop a work base:** Contact your local extension office to learn what interest exists in your county. Locate other adults to help you as you plan courses and instruct and supervise 4-H'ers (see below re certification). Locate a suitable shooting range. Contact local sponsors who can be utilized for fundraising.
- **Certify your instructors:** All your instructors must be certified by a qualified instructor through a 4-H Adult Volunteer Leader Training Workshop. As soon as these instructors or junior leaders are certified, involve them in developing meetings based upon the

project meeting guides. Involve the members to plan the year's activities.

- **Solicit membership, if applicable:** Now that your program is ready, it's time to put it to use. If you need to recruit members, you can arrange a demonstration day for county youth. Enlist just a few clubs or your whole county to plan and implement the demonstration day. Be sure to solicit the expert support of the Department of Natural Resources and other local, state, and federal conservation agencies.

Planning a Successful 4-H Project Meeting

A successful project meeting usually has these ingredients:

- Members do something or help others do something they are interested in;
- Members have fun and make friends;
- Members feel important, recognized, encouraged, and accepted.

The First Project Meeting

During the first project meeting, it is important to get members involved early. As a leader, you have several objectives to accomplish at the first meeting, including:

- Help members get acquainted with you and with each other.
- Introduce the project materials.
- Be sure everyone is enrolled in the project.
- Provide a preview of the project.
- Involve members in a learn-by-doing activity.
- Brainstorm a list of project meeting ideas

for future meetings and plan your program.

- Decide on an activity for the next meeting.

As you plan your 4-H Shooting Sports/Wildlife project year, remember that you must meet government regulations for safety and hunting as well as 4-H educational criteria. The 4-H Shooting Sports/Wildlife Program Development Committee has set minimum requirements for a youth to qualify for out-of-county events. Your county extension agent can give you these minimum requirement hours, as they change year to year.

A Typical 4-H Project Meeting

Typically, a 4-H project meeting has distinct parts. A 1-1/2 hour meeting might be divided in this way:

- Opening activity, flag pledges, roll call, review of last meeting
- Progress reports 10 minutes (or more)
- Demonstrations 10 minutes
- Project activity period 40 minutes
- Business meeting 10 minutes
- Plans for the next meeting 10 minutes
- Refreshments, recreation 10 minutes

Your role and that of the members helping with the meeting is to plan the following:

- What is to be accomplished
- Materials and supplies needed
- Background information regarding the project topic
- What tasks need to be done

- How the members will be involved
- Assignments for next meeting
- Items for the business meeting agenda (with officers)

Roll Call/Review of Last Meeting/ Progress Reports/Demonstrations

The role call should focus on the subject for the project meeting-for example, have the members respond by naming something appropriate.

Progress reports and demonstrations give the members a chance to express themselves and be recognized for their accomplishments. Along with the review of the first meeting, they provide continuity between meetings.

Project Activity Period

The goal of the activity period is to involve all the members (and parents) in a cooperative learn-by-doing activity in order to maximize the opportunity to develop life skills that can be transferred to other situations (e.g., decision making). The key is to have members do something rather than watch or listen to someone or something. Leaders cite several criteria for successful activity periods:

- The members help choose the topic and plan the meeting.
- The members interact and share ideas with each other.
- The members are allowed to learn by doing before being told or shown how (discovery or experiential learning).
- The leader finds out what the members know and then builds on that base by

asking questions and allowing the members to figure out the answer.

- The leader has a clear idea of what he or she wants each 4-H'er to know, feel, and be able to do as a result of the session and selects a teaching method which will accomplish this.

Short Business Meeting/Plans for Next Meeting/Recreation & Refreshments

The business meeting provides members an opportunity to hold office, conduct meetings, and develop leadership skills. For clubs that plan community service activities, participate in county 4-H events, and involve members on committees, the business meeting is important. Limit the meeting to 10 to 15 minutes to allow adequate time for the project activity period. Some clubs have their business portion before the activity period.

Remember when planning the next meeting that every meeting should be a building block for the next. Providing a list of dates and topics helps families plan ahead and become more involved.

Adding refreshments to the meeting gives 4-H'ers the chance to develop responsibility. Assign rotating members to provide refreshments at each meeting.

Hats Off!

As a project leader you have the opportunity to affect the lives of young people. Through your efforts unique individuals will continue to grow and develop into confident, productive, and contributing members of the community.

Table of Contents

With Suggested Age Level (B = Beginner; I = Intermediate)

Acknowledgements i

Introduction: 4-H Shooting Sports/Wildlife Leader's Guide ii

Hunter Ethics and Wildlife Management

1. Discovering the Basic Needs of Wildlife (B)	1
2. Changes in Wildlife Populations (B)	4
3. Understanding the Food Chain (B)	7
4. Learning and Developing Hunter Ethics (B)	10
5. Learning About Game Laws (B)	13
6. The Hunter as a Game Manager (I)	15
7. Wildlife as a Manageable Resource (I)	17
8. Winter Habitat of White-tail Deer (I)	20
9. Identifying Minnesota Game (I)	23
10. Identifying Minnesota Waterfowl (I)	26
11. Winter Habitat of Ring-Neck Pheasants (I)	28

Safety

12. Practicing the Ten Commandments of Shooting Safety (B)	30
13. Eye and Ear Protection (B)	33
14. Dressing for Hunter Safety (B)	36
15. Using a Map and Compass (I)	39

Nomenclature and Shooting Skills

16. Identifying Types, Parts, and Functions of Firearms (B)	42
17. Identifying Parts and Functions of Ammunition (B)	45
18. Identifying Types, Parts, and Functions of Bows (B)	48
19. Identifying Parts and Functions of Arrows (B)	51
20. Determining Dominant Eye (B)	54
21. Fitting the Shotgun or Rifle (B)	57
22. Practicing Aiming Techniques and Trigger Control (I)	60

Special Hunting Skills

23. Stalking and Still Hunting (I)	63
24. Hunting from a Stand (I)	66
25. Hunting by Driving Game (I)	68
26. Assessing Age, Size, and Trophy Status of White-Tail Deer (I)	71

Associated 4-H Activities

27. Designing, Making, and Exhibiting a 4-H Shooting Sports/Wildlife Project (B)	74
---	----

Additional Readings and References	76
---	-----------

Appendix A: Range Commands	78
---	-----------

Appendix B: Premium List	79
---------------------------------------	-----------

1. Discovering the Basic Needs of Wildlife¹

Importance of the Topic

To understand and appreciate wildlife, we need to know their basic needs. This is true for all animals, from the microscopic amoeba to the largest whale. By learning basic needs, 4-H'ers will better understand the principles of conserving, managing, and hunting wildlife. They will better understand wildlife management efforts and programs.



What 4-H'ers Will Do

4-H'ers will be able to:

1. Identify the four basic needs of wildlife (food, water, shelter, space).
2. Understand why removing one or more of these basic needs will disrupt the habitat and/or cause the animal to disappear.
3. Be able to make better informed decisions about wildlife management issues.

Prepare for the Meeting

This activity can be played indoors or outdoors. No materials are necessary. You may enlist the help of junior leaders in planning this activity.

Involving the Members

Habitat Lap Sit:

1. Ask 4-H'ers to number off from one to four.
2. As the groups form, clear a space at the center of the room, or leave space for a circle in an outdoor setting.
3. Assign each group one of the habitat needs (food, water, shelter, space).
4. Form a circle using chains of the four

¹Activity adapted from *Project Wild*, available from the Minnesota Department of Natural Resources, Box 7, DNR Building, 500 Lafayette Road, St. Paul, MN 55155

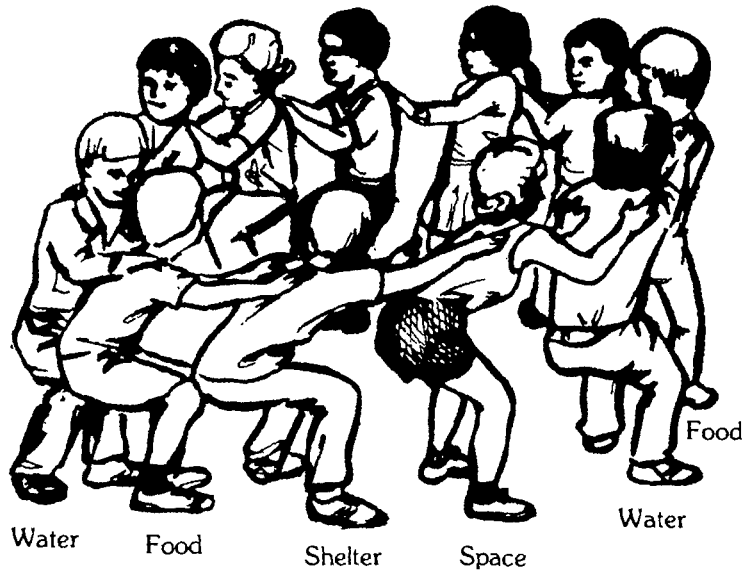

- needs. A member from each of the four groups walks toward the cleared area facing toward the center of the circle until the circle is closed.
5. Ask members to turn to the right together and take one step toward the center of the circle. They should be standing close together, each looking at the back of the next person.
 6. Ask everyone to listen carefully. Instruct them to place their hands on the shoulders of the person in front of them. At the count of three, everyone should sit down on the knees of the person behind, keeping their own knees together to support the person in front. Then say "food, water, shelter, and space—in the proper arrangement—are needed for good habitat for an animal." By now the members are tired and may have fallen. Ask them to stand in place again. At this point discuss the differences and similarities between people and animals as they relate to these basic needs.

7. After the members understand the major point—that the needs of any animal to survive, in proper arrangement, comprise a good habitat for that animal—let the members lap sit again.

This time ask them to hold the sit longer. As they lap sit—still representing food, water, shelter, and space in their appropriate arrangement—identify one of the needs, such as water. Then say, "It is a drought year; the water supply is reduced." Have the 4-H'ers who represent water remove themselves from the lap sit and watch the circle collapse. Try this in several ways—removing one or more elements from the circle: pollution of water supply, urban sprawl limiting shelter and space, soil erosion and herbicides impacting food, etc. Since animals depend on all four, removal of any will have an impact. After you finish the exercise, ask the members to discuss what it means to them.

Questions To Ask

1. Do all animals have the same needs?

Answer: All need food, water, cover, and space. Each type of animal needs slightly different types and amounts of food.

2. Why is it important to provide complete habitat? If a basic need is not filled, will animals stay healthy? Survive?

Answer: Without proper habitat, the animals can't survive.

3. What kinds of changes happen to wildlife habitat when humans move in? How can we reduce the impact of these changes?

Answer: Humans tend to make habitats smaller and more simple—like farmland or parking lots. Wild animals need complex habitats like forests, prairies, and marshes.

Additional questions to ask might include: Who would have an impact on the habitats of various animals—ruffed grouse, pheasant, white-tailed deer, etc.? What is the fifth essential part of a healthy population of animals? (A balanced reproduction rate so that populations gains in young equal losses from death.)

Supporting Activities

Plan a field trip to a nature center or other wildlife area, and observe sources of food, water, shelter, and space for wildlife. Then visit a shopping mall or other urban development within the same general area, and again observe sources of habitat needs. Discuss the perspectives from an animal's viewpoint. You might even want to appoint each member to "be" a certain animal, and have them look for their own special needs in the two different areas.

2. Changes in Wildlife Populations¹

Importance of the Topic

Wildlife need appropriate habitats to maintain their population. Ultimately, wildlife habitat also affects people as part of the ecosystem.



What 4-H'ers Will Do

4-H'ers will be able to:

1. Identify and describe four essential parts of habitat.
2. Describe the importance of good habitat and learn what makes habitat good.
3. Define the term "limiting factors" and give examples.
4. Recognize natural fluctuations in wild animal populations.
5. Demonstrate that the addition of habitat (habitat improvement or increase) influences a wildlife population.

Prepare for the Meeting

This activity should be played in a large area, either indoors or outdoors. You will need information about deer feeding habits, preferences, and cover requirements. A tally person, with paper and pencil, will be needed to keep track of the population after each round.

Involving the Members

Limiting factors may keep wildlife from successfully reproducing and maintaining their population over time. Sometimes the limiting factors keep the population very low or push it to extinction. Other times the limiting factors may hold the population at much higher levels.

Disease, predator/prey relationships, weather, accidents, pollution, habitat improvement, and habitat destruction are

¹Adapted from *Oh Deer!*, Project Wild, Regional Environmental Education Council, 1983, available from the Minnesota Department of Natural Resources.

among these factors. All these can be demonstrated through this game.

The main purpose of this activity is to help members understand the importance of good habitat, as well as understand factors that affect wildlife populations in constantly changing environments.

1. Tell the members that they are about to demonstrate the most essential needs of animals. Review habitat needs with the members—food, water, space, and shelter—and remind members that all the parts must be in correct arrangement or the animals will die.
2. Let the 4-H'ers count off in fours. Make two parallel lines on the ground or floor 10 to 20 yards apart. Have the Ones file behind a line, the Twos, Threes, and Fours file behind the other line.
3. The Ones become deer. All deer need good habitat in order to survive. Ask the members what the habitat parts are. We will assume in this game that the deer have adequate space, so we'll

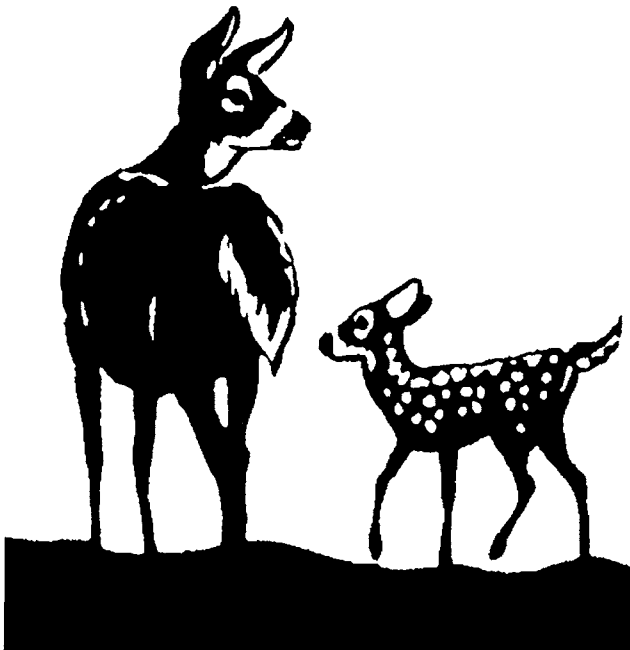

emphasize food, water, and shelter. When a One, or deer, is looking for food, it should clamp its hands over its stomach; when it is looking for water, it puts its hands over its mouth; when it is looking for shelter, it holds its hands together over its head. A deer can choose to look for any one of these needs during each round of the game. The deer cannot, however, change what it is looking for when it sees what is available at the other side during the round. It can change what it is looking for in the next round, if it survives.

4. The Twos, Threes, and Fours are food, water and shelter. Each 4-H'er picks, at the beginning of each round, which part he or she will play during that round. The members show which part they are playing, using the same signals as the deer.
5. The game starts with all the members lined up on their respective lines and with their backs to the members on the other line.
6. Begin the first round by asking all the members to make their sign. Give the members a few moments to get their hands in place. As you look at the two lines, you will normally see a lot of variety. Sometimes, however, the numbers confer and all make the same sign. That's okay, but don't encourage it. For example, all the members in the habitat might decide to be shelter. That could represent a drought year with no available food or water. Again, they may choose to be all water, representing a flood.
7. When all the members are ready, say "Go!" At the word "go," each deer and each habitat part turn to face each other, continuing to hold their signs clearly. When the deer see the habitat part they

need, they run to it while holding their need signal. The deer then takes the habitat need back to the deer line, and it becomes a deer. The original deer has met its needs and is reproducing as a result. Any deer that fails to find its habitat need dies and becomes part of the habitat. Let the tally person record the number of deer at the end of each round. In the next round, the deer that died is a habitat part and is available to the deer that are still alive.

Note: When more than one deer reaches a habitat, the member who gets there first survives. Habitat parts stay in place on their line until a deer needs them. Members can change the part they play from round to round.

8. Keep track of how many deer there are at the beginning of the game and at the end of each round. Continue the game for at least ten rounds so that the deer population trends can be seen.
9. Other influences on the deer population can be shown with the game: the predator/prey relationship, game management, and disease.
10. At the end of ten or more rounds, discuss the game with the 4-H'ers. Encourage them to talk about what they experienced. For example, they saw a small herd of deer begin by finding more than enough of its habitat needs. The population expanded over two or three rounds, until the habitat was depleted and then deer died and they returned to the habitat. This happens in nature also.

11. Use the written score sheets to demonstrate fluctuations in the number of deer, with each round representing a year. This is a natural process and the limiting factors are the causes. As long as enough animals exist to reproduce, habitat is good, and the limiting factors are not excessive, the population peaks, subsides, and rebuilds in cycles.

Questions To Ask

To summarize, ask the members what they have learned. What do the animals need to survive? What are some of the limiting factors that affect their survival? What happens to the population over the long term if habitat is improved or added? Are wildlife populations stable, or do they tend to fluctuate? Is nature really in balance, or are ecological systems involved in constant change?

Supporting Activities

This game can be modified to show the predator/prey relationship, game management through hunting, the impact of weather and pollution, or the destruction of habitat by manipulating the habitat numbers and introducing factors between the deer and the habitat.

Use the units on Winter Habitat of White-tail Deer and Winter Habitat of Ring-Neck Pheasants to further explore habitat influences. These show the difference between winter and summer foods and demonstrate that either season's foods can be a limiting factor.

3. Understanding the Food Chain

Importance of Topic

It's important to understand the food chain when studying, observing, or hunting animals, since food is one of the basic needs of all animals. Studying the basic food chain, or sometimes the more complicated food web or nutrient cycle, also helps us conserve, manage, or hunt in a habitat.

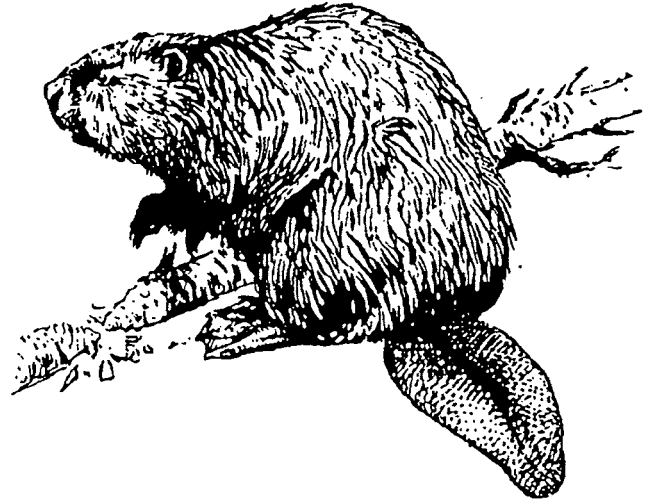

What 4-H'ers Will Do

4-H'ers will be able to:

1. Identify some of the food needs of local wildlife.
2. Identify the position of some animals in a food chain and a simplified food web.
3. Learn that the starting point of all food chains and webs is the soil and its nutrients, and that all nutrients are cycled through animals to the soil.
4. Learn that breaking the food chain anywhere will affect the rest of the chain.
5. Make personal decisions about animal management, observation, and hunting through the understanding of the animal's food chain.

Prepare for the Meeting

You should familiarize yourself with how food chains and webs work. You should be able to place a list of local animals into food chains or webs. You also should know the three basic parts of the food web: decomposers, which change the animal matter into solid nutrients; producers, which convert the soil nutrients to plant life; and consumers, which convert plant and animal life to animal matter (wastes).

Tell the members that decomposers are worms, insect larvae, bacterial and fungi; that producers are plants, from one-celled plants to the tallest trees; and that consumers include plant-eating animals. To prepare for the meeting, gather paper and pencils and prepare a sample food chain on a flip chart or overhead. You can perform the activity indoors or preferably, outdoors.

Involving the Members

This activity can be time-consuming; you may need to set time limits because of the many questions that could be generated. Recommend to particularly curious youth that they consult an ecology book for additional reading.

To start the activity, pass out the paper and pencils and ask the members to choose a local animal and write its name at the top of the paper.

In your brief introduction, define decomposers, producers, and consumers. Tell members that all nutrients for life come originally from the soil or water. Then ask the members to make a block near the bottom of their paper and label it "Soil Nutrients."

Ask the 4-H'ers how these soil nutrients (food) are used and what uses them (plants). Ask the members to make a small arrow pointing upward to a second block labeled "Plants."

Next, ask the members which animals eat plants. These are the herbivores. Tell the members to make an arrow upward from the plant block to another block labeled "Plant Eater." If the member's animal is a plant eater, he or she should place its name in the block.

Ask the 4-H'ers what eats the plant eater. The answer is a meat eater (carnivore or predator), or an animal that eats both plants and animals (omnivore). These animals can be as small as a shrew or as large as a bear, depending on the size of the plant eater. Ask the members to draw another arrow upward to a block labeled "Small Animal Eater." If the member's animal fits that category, he or she should place its name in that block.



Then ask what eats the small animal-eaters. The obvious answer is a larger animal-eater. The member is then asked to draw another arrow to a block labeled "Large Animal Eater." If the member's animal fits this category, the name is inserted.

Ask what eats the large animal-eaters. The answer is human beings. Ask the members to draw another arrow upward to a block labeled "Human Beings."

This is a typical food chain of most animals. By now, many members have questions. Some can be answered by asking the members to state the main or preferred food of the animal. Some animals have seasonal diets, while others eat everything that becomes available. If this is the case, ask the members to start with their animal in the proper block and work downward, asking what is the main or preferred food of the animal. They should put that name in the appropriate block and draw an arrow downward to that block. Then ask the same questions for that animal and

have them draw an arrow downward, etc. This, then, would be the food chain for that animal. For animals that eat everything, the arrows may point to several of the lower blocks, (i.e., human beings eat large animal-eaters, small animal-eaters, plant eaters, and plants).

For an additional activity, enlarge the food chain to include decomposers. Do this by adding natural death of the animals and plants and the waste that is contributed by both plants and animals. To the food chain, add blocks on each side labeled "Natural Death" and "Waste." Below these, draw arrows downward to blocks labeled "Decomposers." Name several decomposers and ask the member to name others. Have them draw arrows back to the

A Food Chain

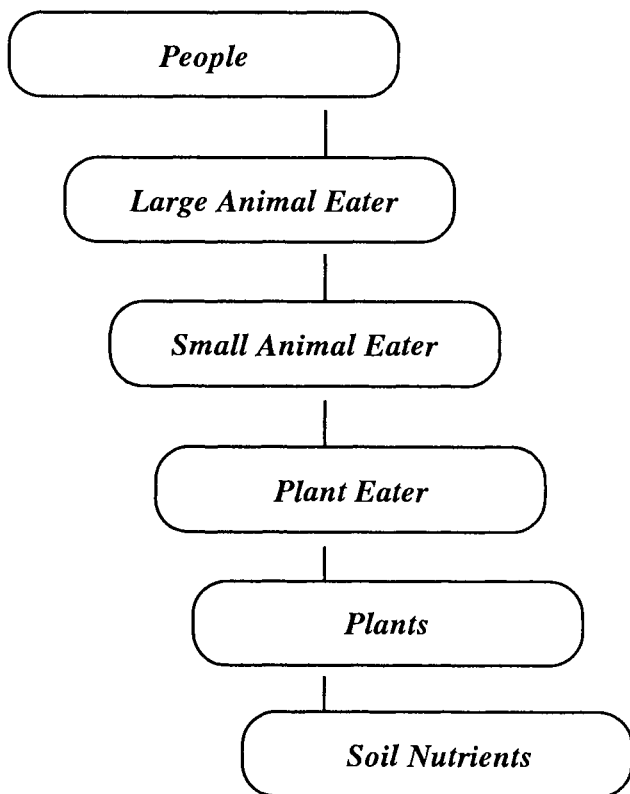

soil nutrient block. This completes the simple food web or nutrient cycle.

Questions To Ask

1. Name three producers.
Answer (sample): Trees, grasses, algae.
2. Name three consumers.
Answer (sample): Humans, birds, snakes.
3. Name three decomposers.
Answer (sample): Fungi, bacteria, earthworms.
4. What happens if we remove a link in the food chain?
Answer: Food chains or webs are very complex, with many interrelationships. If one link is broken, it can affect many other types of organisms, and even lead to the extinction of a species.
5. What is a carnivore? A herbivore? A omnivore?
Answer: A carnivore is a meat-eater. A herbivore is a plant-eater. A omnivore eats both plants and meat.

Supporting Activities

Visit a wooded area and try to find food chains within small areas, i.e., trees linked to grubs linked to birds linked to larger birds. Gather some examples of decomposers, producers, and consumers. Project Wild has an activity (game) called "Deadly Links" that introduces pesticides into the food chain and demonstrates their effects.

4. Learning and Developing Hunter Ethics

Importance of the Topic

Conservation is the wise use of our natural resources. Hunters practice conservation by understanding wildlife management and by learning and obeying game laws and firearm regulations. It is important that 4-H'ers understand and practice conservation.

What 4-H'ers Will Do

4-H'ers will be able to:

1. Learn and practice the six rules of hunter ethics.
2. Understand the reason for conserving wildlife and natural resources.

Prepare for the Meeting

You will need to gather the following supplies for the meeting:

1. Pencils and paper
2. Hunter and farmer clothing
3. Mock guns

4. Other equipment for the members to use when role-playing the six rules of hunter ethics

Six Rules of Hunter Ethics

1. I will consider myself an invited guest of landowners, seeking their permission and so conducting myself that I may be welcome in the future.
2. I will obey the rules of safe gun handling and will courteously but firmly insist that others who hunt with me do the same.
3. I will obey all game laws and regulations and will insist that my companions do likewise.
4. I will do my best to acquire marksmanship and hunting skills that assure clean, sportsmanlike kills.
5. I will support conservation efforts that assure good hunting for future generations of Americans.
6. I will pass along to younger hunters the attitudes and skills of a true outdoor person.

You will need to review and understand the six rules of hunter ethics.

Several learning aids (see reference section) will help you reinforce the learn-by-doing activities outlined in this guide. You will want to order them well in advance.

Involving the Members

Present the six rules of hunter ethics to the members, using a chalkboard or other visual aid. Give the members a few minutes to think what hunter ethics means to them. Then ask each one to share his or her ideas with the group. If you have a large group, have them share in groups of four or five.

After this short introduction, involve the members in a series of role plays to



show their understanding of the six rules. You may want to have your junior leaders design various situations ahead of time or help each group design its own. Often just handing out one of the six rules to each group is enough to get them started. Give each group 10 minutes to prepare a skit and get into costume.

After each group has presented its skit, allow a few minutes to discuss the following scenarios and come to a group consensus on how they would handle these situations:

1. You track a large white-tail buck to the edge of an area where you have permission to hunt. You have been tracking the animal for several hours, and now you can see him, silhouetted against the sky at the edge of a field, just over the fence line. The buck is standing on land where you do not have permission to hunt. Would you take your shot?
2. One of your friends brings a firearm to school and hides it in his locker. He is showing it to his other friends secretly, and even points it at them, pretending to pull the trigger. What would you do?
3. You are hunting with a friend who gets her limit of mallard duck within the first two hours of the day. Your friend doesn't want to go home yet, and wants to keep hunting. She suggests that you help hide her game in case you are questioned by a Conservation Officer.
4. You are bow and arrow hunting, and have the opportunity to shoot at a large white-tail doe. However, you know that the brush in front of you will obscure the shot, and it is very likely you will only wound the animal. Would you take the shot?
5. Your friends have all joined a group to

restore wetland habitat in their area. On Saturdays, they go to pothole waters to plant bushes and trees that will serve as wildlife habitat. They also put up wood duck boxes. You don't go with them, even though you hunt ducks, because you are too busy with computer games. Are you being an ethical hunter?

6. You are an avid wildlife photographer, and especially good at photographing pheasants and grouse. Your younger cousin wants to learn more about the outdoors, and wants you to take her into the woods on one of your photography sessions. You don't want to be bothered, because she is from a large urban area and doesn't know much about forests and wetlands. Should you take her with you?

Questions To Ask

1. What is an ethical hunter?

Answer: One who sets and maintains his or her behavior according to a hunting code and uses the six rules of hunter ethics as the basis for this code.

2. Why are hunting laws necessary?

Answer: To ensure the safety and

welfare of people, to protect and conserve wildlife, and to ensure an equal opportunity for everyone to hunt

Supporting Activities

Arrange for club members to report on any of these topics:

- Federal wildlife laws
- Turn in Poachers (TIP) - How and why was it organized?
- How species become endangered
- Hunters' contributions to conservation
- Hunting: is it a right or a privilege?
- The advanced Hunter Education Program for members 16 years and over
- Spending a day/night on patrol with a conservation officer

A Conservation Officer from the Department of Natural Resources would be an excellent guest speaker. He or she can provide members with current game laws and regulations, as well as an overview of habitat preservation and restoration activities.

5. Learning About Game Laws



Importance of Topic

It is critical to understand state game laws before hunting. Minnesota Conservation Officers frequently hear violators say, "I didn't know." Game laws are complex; their purpose is to enhance and perpetuate the sport, not to hinder and stop the hunt.

Prepare for the Meeting

Obtain (from your County Auditor or Department of Natural Resources office) and become familiar with the following:

1. Big game synopsis (deer and bear)
2. Small game synopsis (small game and upland)
3. Migratory waterfowl synopsis (ducks and geese)
4. Turn In Poachers (TIP) brochures and information

With junior leader involvement, prepare questions on current game laws and regulations.

Involving the Members

Involve the members in a group discussion, presenting several current game laws. Ask if they understand the law, and have them summarize it. Let each member write down a question about the law, and collect and answer each question.

You might want to divide the 4-H'ers into several groups, giving each four or five laws to discuss. A group spokesperson can

What 4-H'ers Will Do

4-H'ers will be able to:

1. Learn what types of hunting are available in Minnesota and discuss regulations governing each.
2. Learn who needs a license or a firearms safety certificate and what stamps are needed.
3. Find out where to obtain a synopsis for a species they want to hunt.

then present their summary to all the members.

Discuss the Turn In Poachers (TIP) program of Minnesota. This program helps enforce game laws by making the public aware that poaching is a problem, and that conservation officers need help protecting resources. Discuss why the program is needed.

Questions To Ask

1. How can a firearm be legally transported in Minnesota?

Answer: A firearm can be transported only if it is completely enclosed in a case and unloaded (this also protects firearm from damage).

2. Are snowmobiles, all-terrain vehicles and motorboats considered motor vehicles?

Answer: Yes.

3. On opening day, what time can I put out my decoys?

Answer: 11:00 A.M.

4. What is the limit on pheasants?

Answer: The limit is two, and only cocks may be hunted.

5. How high may I build a permanent deer stand?

Answer: The permanent stand may be up to 16 feet tall, while a portable may be placed at any height.

6. How can I receive a firearms safety certificate?

Answer: By attending a firearms safety training class. You must be at least 12 years old.

7. Who is your Conservation Officer, and how can you contact him/her?

Answer: You can call your local Department of Natural Resources office to find out.

Supporting Activities

Invite a Conservation Officer from the Department of Natural Resources to your group to talk about changes in game laws.

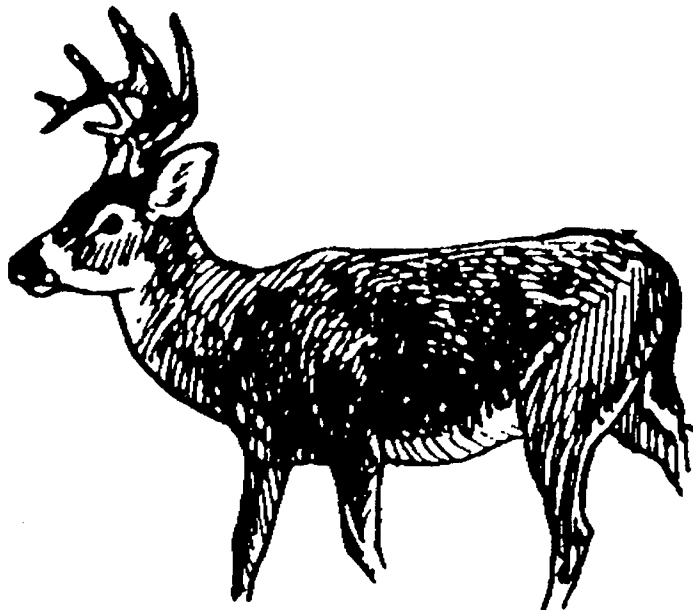

6. The Hunter as a Game Manager

Importance of the Topic

Wildlife is a renewable resource. 4-H'ers can discover their role in game management as hunters.

Contact a Department of Natural Resources representative and compile statistics on herd or flock population, numbers harvested, carrying capacity, and major non-hunting impactors (poaching, car kills, etc) for your local area.

What 4-H'ers Will Do

4-H'ers will be able to discuss the major components of game management:

1. Habitat.
2. Carrying capability.
3. Predation, including human.

Involving the Members

After playing the game and recording the round results from the unit "Changes in Wildlife Populations," discuss the game results. Substitute actual local statistics into the game results. During the discussion remove hunting as a control factor and estimate herd/flock growth for the next 1, 3, 5 and 10 year periods. Does the population get increasingly larger? Does it maintain a high population, or does it continue to crash and cycle?

Prepare for the Meeting

Select a meeting leader to organize a game, such as that found in the unit "Changes in Wildlife Populations," to get the group thinking about habitat, carrying capacity, selective harvesting, external impactors (poachers, etc).

Ask the 4-H'ers to estimate their own environment's carrying capacity (their environment would be their house). How much of an increase in human population could their habitat (house) support before



the population crashed? What would be the limiting factor in the crash (shelter, food, water, space)?

Questions to Ask

1. What is the difference between game animals and other wildlife?

Answer: Game animals may be hunted according to regulated seasons and bag limits.

2. What is wildlife management?

Answer: Wildlife management is the science of managing wildlife and its habitat, for the benefit of the entire biota (all plants and animals in the environment, including humans). Management means conservation (wise use) and in some cases preservation (non-use).

3. What is carrying capacity?

Answer: Carrying capacity is the number of each wildlife species the habitat can support throughout the year without damage to either the animals or the habitat. In most cases the critical carrying capacity is

during the winter and early spring season.

4. How can excess animal populations be controlled?

Answer: They can be controlled through hunting or naturally through starvation.

5. How can I hunt responsibly?

Answer: Responsible hunters don't take long shots (might wound an animal, so that the game suffers needlessly); they identify their game or target; they retrieve down game; they respect others and others property; and they participate in habitat restoration and protection projects.

Supporting Activities

Invite a Department of Natural Resources Wildlife Manager into your meeting to talk about wildlife management. Use videos or other informational films listed in the "Other References" section of this book.

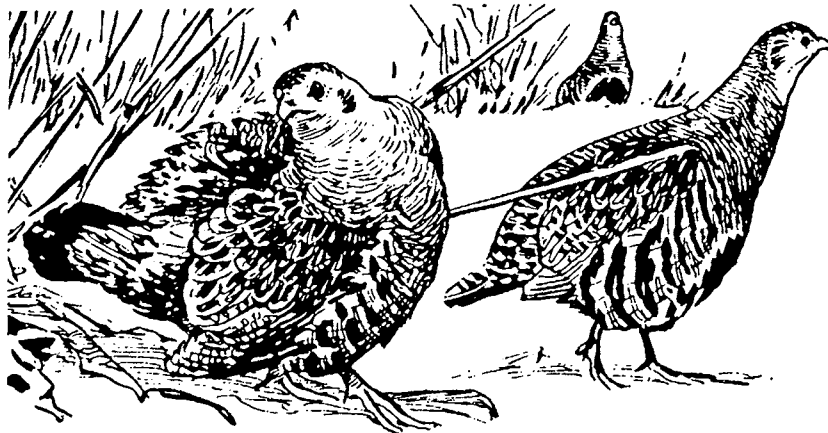

7. Wildlife As a Manageable Resource

Importance of the Topic

All living things live, reproduce, and die. In wildlife management, we study how we can impact animal populations to meet human needs. Without proper management, some wildlife species would not be able to withstand the presence of humans.

One way to categorize resources—the things all around us—is according to their relative life span. Trees, animals, and sunlight are renewable resources. We cannot store them, or can do so for only very short periods. Renewable resources cannot be saved for long periods but are self-replacing through reproduction. By comparison, rocks, taconite, and oil are non-renewable resources. They are not living, and they do not reproduce or die. They may be saved for very long periods and they occur in limited amounts.

Management is based on the principle of conservation (wise use). We can increase a population through management. An example is the white-tailed deer. Shortly after 1900, less than one million white-tails lived in the U.S., and many states had closed their deer hunting seasons. Today, several states have white tail populations over one million and all states with white-tails have reopened the deer season.

Prepare for the Meeting

Let the junior leaders prepare an introduction to the concepts of renewable resources and wildlife management.

What 4-H'ers Will Do

4-H'ers will be able to:

1. Distinguish between renewable and non-renewable resources.
2. Identify different types of wildlife management techniques.
3. Understand why it is important to manage for wildlife.



You will need dice for several groups, calculators, chalkboard or large pad of paper, and pencils.

Prepare game Condition Cards. You will need:

- 70 3" x 5" index cards
- 40 cards, each listing one management procedure. Samples include: "Deer yarding area is paved for new highway," "Small 20-acre cuts are made in the middle of mature aspen."
- 30 cards listing a choice of management procedures. Samples include: "Should doe permits be issued?" "Should hunting season be extended two weeks?" and "Should salt blocks be set out by state game managers?" These cards will also need a number on the back for population decrease and increase, i.e., "Doe permits will cause the population to decline by 10," "Salt blocks will increase population by 15."

Involving the Members

Before you have the members play the game described below, briefly discuss the ideas of renewable resources and wildlife management. Discuss different wildlife management techniques. Meet with junior leaders to discuss the game and have them present the introduction and write the cards.

This game may be played with as few or as many groups as you want. By having several groups, the members may see the effects of different management decisions on the populations. Keep track of the populations on a chalk board or large pad to allow the group to compare the different results. You will need at least one die. Each group needs a pencil and piece of paper or

a calculator. You will also need at least the 70 Condition Cards described under "Prepare for the Meeting."

To play the game:

Each member or group of members manages a white-tail deer herd that begins with 100 animals. The carrying capacities of their environments are each 100 deer. If the population becomes greater than 200 or less than 2, it becomes extinct. Wildlife managers are also sensitive to public opinion (expressed by letters in the game). If the manager(s) receive more than 200 letters the members are also out of play.

Population changes are caused by the Condition Cards and the roll of a die. One card is chosen and read aloud, then each group rolls the die to determine the change in their population or the number of letters, depending on the card. Give each group enough time to calculate the change in populations (they will need to figure out whether the management procedure is good or bad for their populations, and use a plus or minus to calculate the herd). Members should know their population number at each turn and also how many letters they've received.

Some cards require members to decide between two management procedures,



such as, "A hunting season is requested. Do you wish to allow hunting in your area?" Before rolling the die, each student must make the decision. The roll of the die then determines the number of letters received from people who disagreed with the decision. The population change is indicated on the back of the card.

Play for 20-30 minutes, until the students appear to have grasped the trends that occur. Members with fewer than 200 and more than two deer, and less than 200 letters were successful as managers. Be certain to summarize and discuss the implications of the game. What seemed realistic? What didn't? What was missing? Discuss different management strategies. How important is public opinion in managing wildlife?

Questions To Ask

1. Are there any wildlife species that do not require management?

Answer: No; human impact throughout North America (and the world) has changed all natural habitats. Some species, like those threatened or endangered, need special management. Other species such as robins, chickadees, and crows need very little direct management, just adequate laws to protect them.

2. What are some examples of managing for wildlife?

Answer: Putting out bird houses makes more nesting cavities available so that more cavity-using birds will have young. Planting a corn food plot by a shelterbelt will provide extra food for certain birds and mammals; this might be just enough to help them get through a severe winter.

Supporting Activities

The Department of Natural Resources has a volunteer program for older members (14 and up) that includes working at deer check stations. Members may arrange to spend a day working with the area wildlife manager or accompanying the Conservation Officer.

A club project such as building wood duck houses or making a bluebird trail can demonstrate good wildlife management. References at the end of this book list excellent resources for both of these projects.

Take members to a Wildlife Management Area (WMA) and request a guided tour from your area DNR Wildlife Biologist. Ask your guide to discuss such topics as: the reasons for having WMAs, purpose of food plots, when to use supplemental feeding, releasing captive-raised wildlife like pheasants, and controlling predators.

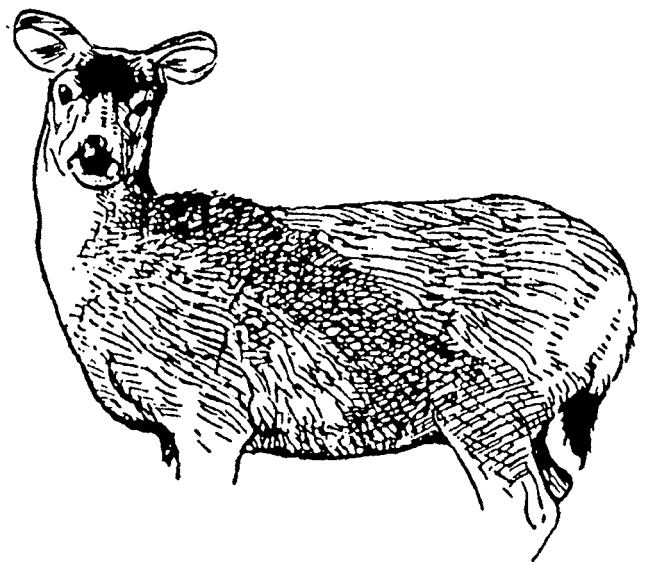

8. Winter Habitat of White-tail Deer

Importance of the Topic

Several states have large white-deer herds in varying habitats. Understanding deer food and cover habits helps members see how deer can be managed. Improving or preserving habitat is the primary way we can influence white-tail deer populations.

What 4-H'ers Will Do:

4-H'ers will be able to:

1. Identify winter foods that are essential to white-tailed deer.
2. Understand the relationship of winter habitat to healthy wildlife populations.
3. Recognize appropriate winter deer habitat.

Prepare for the Meeting

The leader or junior leader should collect six or more samples of winter habitat—i.e., wild aster or goldenrod as non-woody food; white cedar as winter food; lowland cedar, spruce, or cattails as winter cover. See the “Questions to Ask” section for more information about white-tail deer habitats. The book *Landscaping for*

Wildlife by Carrol Henderson provides additional information about building habitat for white-tail deer. You can order a copy from the Minnesota Department of Natural Resources, 500 Lafayette Road, Box 7, St. Paul, MN 55155.

Involving the Members

Spend a few minutes discussing the components of habitat—food, water, cover, and space. Help members identify what makes a good winter habitat. Through a series of questions, arrive at the idea that food and cover are the most critical needs of deer—especially in winter. Place all samples of the winter habitat collected before on a table. Assign a number to each sample. Let the members write the correct name for each specimen and list the item as a food, a cover plant, or both. Allow the members a few minutes to identify the samples. Then work with the group to compare their answers. Discuss each specimen's habitat role.

After the identification session, divide the group into teams of three. This will be a time to learn how to build a winter habitat plan. (Use *Landscaping for Wildlife* for suggestions.) Have each team sketch a design for providing winter habitat for white-tail deer. Compare the designs.

Questions to Ask

1. How big are deer when they are born? How big are they as adults?

Answer: Deer are usually 3 to 5 pounds at birth, and up to 300 pounds as adults; the average adult weighs about 100 pounds.

2. How long do white-tail deer live?

Answer: 13 to 15 years.

3. How far do white-tail deer migrate?

Answer: Their migration depends upon the availability of habitat--they need about 1/2 square mile for a wintering (or yarding) area. They may move many miles to reach this wintering area.

4. Where do white-tail deer live and what do they eat?

Answer: They are edge animals, which means that they do not like completely open or completely forested areas. They eat grasses, acorns, morels, etc. in the spring. Their winter foods are corn, acorns, and various woody plant twigs.

5. What is browse?

Answer: Browse is woody food material. Deer also graze, which means feeding on grasses and non-woody plants.



6. What non-woody plants are important deer food before the snow gets too deep?

Answer: Wild aster, goldenrod, and poison ivy.

7. Which browse does a white-tail deer prefer--white cedar or red-osier dogwood?

Answer: The deer prefers white cedar; it forms dense stands often used during heavy winters. Red-osier dogwood is preferred in December and January.

8. What are some other species of deer browse available?

Answer: Mountain maple, honeysuckle, staghorn sumac, oak, beaked hazel, alternate-leaved dogwood, red maple, and juneberry.

9. What are some less desirable but still moderately nutritious species?

Answer: Hard maple, black ash, mountain ash, chokecherry, basswood, white birch, some willows, hazel, and aspen.

10. Which is better for deer yarding: large areas featuring only one type of tree or shrub, or ones with various kinds of cover and openings?

Answer: White-tail deer avoid the former, if they can, except in the case of northern bog areas where white cedar and/or black spruce are dominant.

11. Where is a deer yard most likely to be found?

Answer: In lowland cedar or spruce swamps and in river bottom areas.

12. In agricultural areas, what are the winter food habits of deer?

Answer: In the winter, large herds of white-tail deer feed upon standing corn, soybeans, alfalfa, and fruit trees.

13. In agricultural areas, where do deer find shelter?

Answer: In tree-lined bottomlands along streams and rivers, field woodlots, shelterbelts, willow thickets, and cattail marshes.

14. What are some common habitats of white-tail deer?

Answer: White-tail deer are very well distributed, and can be found in any of the following:

- *Occasional backyard*

- *Farmsteads/farm woodlots/fence rows*
- *Row crops*
- *Prairies and grasslands*
- *Agricultural wetlands*
- *Forest wetlands and rivers*
- *Deciduous forests*
- *Coniferous forests*

Supporting Activities

Visit an agricultural area and look for signs of deer presence, including tracks and scat. Depending on the evidence of deer you find, discuss what makes the area a prime location for deer or what changes need to be made to attract deer.

Type of Plant/Cover	Winter cover	Winter browse	Summer cover	General browse
Wild aster				X
Poison ivy				X
Shelterbelts	X		X	
White cedar	X	X		
Red-osier dogwood	X	X		
Willow thickets			X	X
Mountain maple				X
Lowland cedar	X			
Goldenrod				X
Spruce swamps	X			
Staghorn sumac				X
Beaked hazel				X
Aspen				X
Black ash				X

9. Identifying Minnesota Game

Importance of the Topic

Your 4-H'ers will need identification skills to hunt, observe, and study game animals. To identify animals, the member needs to make accurate observations under varying conditions and needs to know how to classify or group animals with different characteristics. The member also will develop skills in data gathering and analysis. As members learn the natural history of game and how to identify species, they will become more responsible game hunters and will have positive hunting and observation experiences.

What 4-H'ers Will Do

4-H'ers will be able to:

1. Identify most of the game animals in Minnesota.
2. Learn some distinguishing characteristics of game animals.
3. Learn about classification systems and classify the game animals by taxonomic and other characteristics.
4. Learn some natural history of Minnesota game animals.

Prepare for the Meeting

The length of this activity will depend upon member interest; be flexible. Involve the junior leaders in planning and running the meeting. Ask them to collect the pictures and descriptions of the game animals. Gather reference material such as *The Wildlife Reference for Minnesota Youth* (Minnesota Extension Service, 4H-BU-0314), which is a good source of drawings and descriptions of game animals. You need two copies, one to cut up and the other to use as a reference. Also bring to the meeting magazines and publications such as *Upland Game Birds*, published by Federal Cartridge Corporation, and the publication *North American and Big Game Animals*. Write Illinois and Missouri conservation departments for posters of game animals.



Involving the Members

Activity 1: Divide the members into two groups of equal size. Have the junior leaders cut out the names and descriptions of the animals from the reference material. Give the members of one group an animal name and the members of the other group the corresponding descriptions. They should check with the leader and the uncut reference book for correct matches. When a pair is matched correctly, the two groups should find a picture of the animal. This process should be repeated until all of the animals are matched with their descriptions.

Activity 2: Briefly discuss the reasons for grouping or classifying animals. Point out that in the grouping system used by biologists, animals are classified into large groups that have relatively few similarities. They are then grouped into smaller categories that have more similarities. For example, rabbits and foxes are in the mammal group (class). Mammals are broken down into smaller groups (orders)

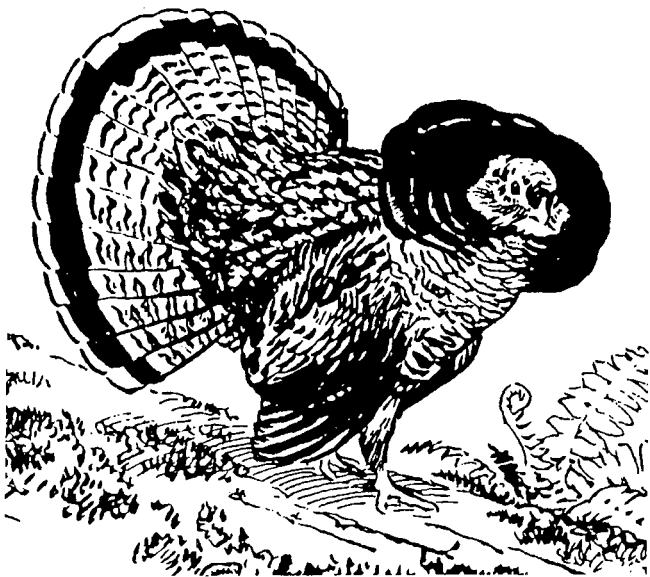

depending upon feeding methods, number of teeth, size of the skull, color, and other characteristics.

Place the paired animal names, descriptions, and pictures so everyone can see them. Pick some categories for the members to use in grouping the animals. You can have the 4-H'ers group the animals by order. Possible categories are herbivore, carnivore, and omnivore; birds and mammals; forest, wetland, and prairie dwellers; hibernators and, non-hibernators; and non-migrants. Enough comparisons should be made so that the members realize that many characteristics may be used for comparing small game animals.

Questions To Ask

1. Why is it important to classify animals using a taxonomic system?

Answer: This system is a way of organizing all living things. These groups indicate which things are most similar to one another and in what ways. For example, rodents are herbivores. If we find an animal that looks like a rodent, then we also suspect that it eats mostly plant materials.

2. What rodents are game animals?

Answer: Muskrat, beaver, and squirrels.

3. What are the characteristics of most small game birds?

Answer: They are ground-feeding herbivores, medium to large size. They are called gallinaceous or chicken-like birds and include the turkey, grouse, prairie chicken, and quail.

4. Many of the small game animals are carnivores (weasel, red fox, fisher, etc.). What are some of their characteristics?

Answer: They are mammals, and most eat some meat. They have large canine teeth and relatively large brains and skulls. Other carnivores are bears, coyotes, and wolverine.

3. Individual small game animals: specific characteristics, methods of hunting and trapping.
4. Small game populations and distribution in Minnesota.
5. Small game seasons and limits.

Supporting Activities

Let the members pick one of the following topics and present a report to the group:

1. One of the orders of mammals or birds that include small game animals: rodents, carnivores, gallinaceous birds, or marsupials.
2. The organization of the classification system of animals and plants: kingdom, phylum, class, order, family, genus, and species.

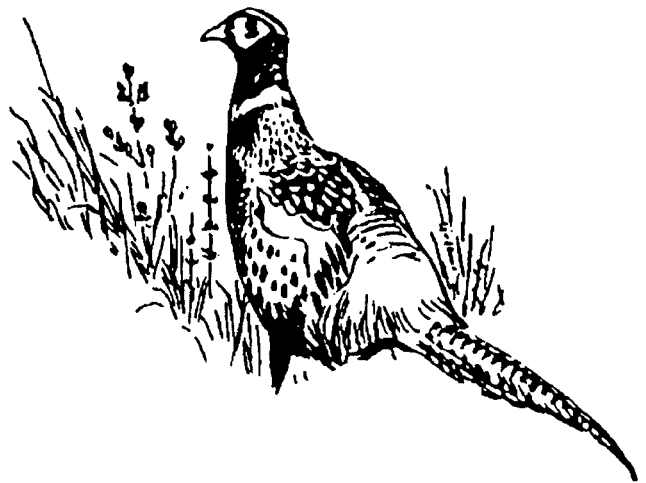

10. Identifying Minnesota Waterfowl

Importance of the Topic

Identifying wild ducks, geese, and swans is an essential skill for a successful hunter or a person who merely enjoys wildlife. People who can identify these fascinating birds will enhance their bird watching and other wildlife conservation skills. Hunters need to identify waterfowl because hunting regulations specify ducks, geese, and swans by species.

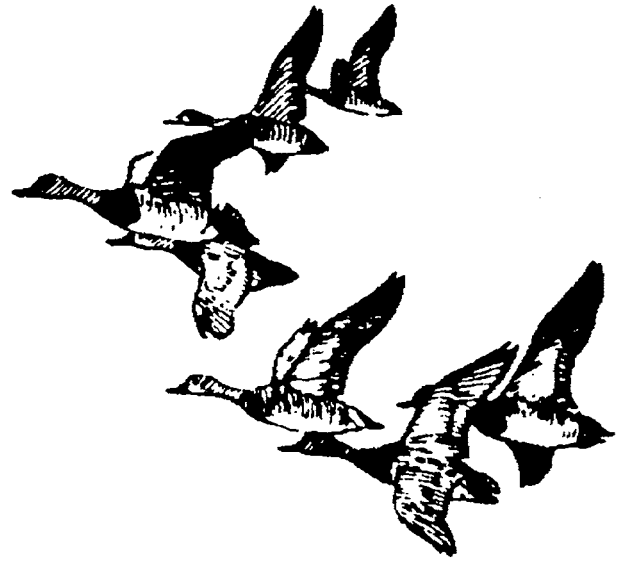

Prepare for the Meeting

Involve your junior leaders in planning before the meeting. Once tasks are agreed upon, support them as they locate and obtain needed materials and resources.

What 4-H'ers Will Do

4-H'ers will be able to:

1. Identify ways in which wild ducks, geese and swans differ from other birds.
2. Identify species by characteristics such as shape, color pattern, flight patterns, and habitat.
3. Appreciate wildlife and habitat conservation.

Bring to the meeting the following aids:

1. A good color-identification book such as *Ducks at a Distance—Waterfowl Identification Guide*, U.S. Department of Interior, Fish and Wildlife Service, obtained through Superintendent of Documents in Washington, D.C.; or *Ducks, Geese, and Swans of North America*, Francis T. Kortright, Bellrose (available at the library).
2. *Minnesota Firearms Safety Training*, Minnesota Department of Natural Resources.
3. Mounted samples of several duck wings.

This meeting can also be adapted to an outdoor setting. Make sure the 4-H'ers dress appropriately. Have them bring binoculars, pencils and notepads. Be sure to choose an outdoor setting that is appropriate duck, goose, or swan habitat.

Involving the Members

Indoors: Make sure that each member or each group (three to four) have a copy of *Ducks at a Distance* or *Minnesota Firearms Safety Training* so that they can study the illustrations.

Spread out the sample duck wings on a table so the 4-H'ers can identify species, working individually or in teams of three to four with their reference books.

Outdoors: Working in groups of two or three, have members identify the various waterfowl that are visible, either flying or in a habitat/pond setting. Make sure they agree on their identification. Working outdoors helps prepare the 4-H'ers to make quick identifications.

Review flight patterns of waterfowl species with the groups, to help them make identifications. You will have your best luck viewing groups during migration, either in the spring or fall. Be sure to dress safely (see section on Dressing for Hunter Safety) if you choose to view waterfowl during open hunt seasons.

Questions to Ask

1. How many species of ducks are common in Minnesota? Of geese? Of swans?

Answer: 15 species of ducks, 3 of geese, and 2 of swans.

2. What are the two major types of ducks?

Answer: Puddle (dabbler) or diving.

3. What is the difference in flight patterns between puddle and diving ducks?

Answer: Diving ducks run across the surface of the water during flight takeoff; puddle ducks jump out of the water into flight.

4. What unique wing color patterns are associated with puddle ducks?

Answer: Puddle ducks have an iridescence of the speculum, while diving ducks in Minnesota do not have this feature.

Supporting Activities

Invite a Department of Natural Resources or U.S. Fish and Wildlife Service speaker to present identification information to your group. Invite a taxidermist to talk about characteristics of waterfowl.

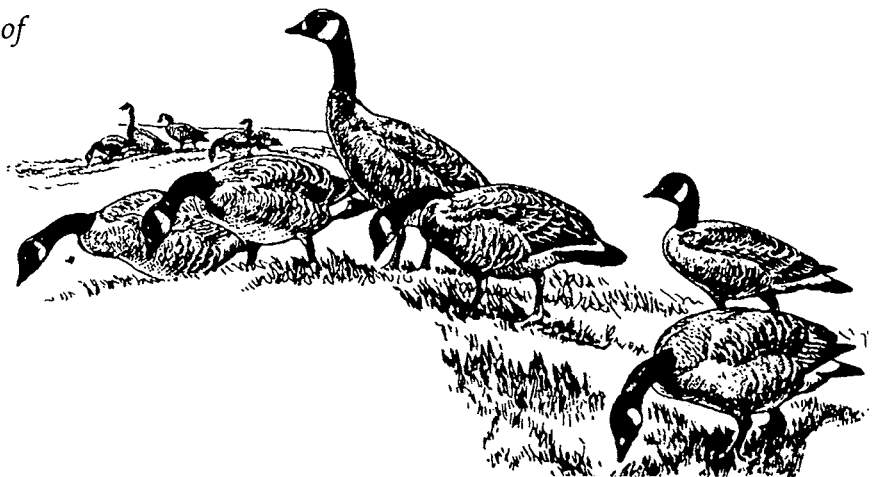

11. Winter Habitat of Ring-Neck Pheasants

Importance of the Topic

The Midwest was once the North American center for pheasant hunting. Today pheasant populations in the Midwest suffer from lack of winter habitat. Worse, the plight of the ring-neck is indicative of the future for most farmland wildlife species whether game or nongame. They have all suffered dramatic losses and for essentially the same reason—lack of winter habitat.

Prepare for the Meeting

This is a 30 to 40 minute activity. It can be expanded to include an outdoor session, but may be conducted entirely indoors. Each member should be encouraged to bring two samples of winter habitat of ring-neck pheasant—i.e., a cob of corn as winter food, a cattail as winter cover, etc. Junior leaders also should bring several examples of plant material, to provide a back-up to the member materials.

Involving the Members

Spend a few minutes discussing what the components of habitat are—food, water, cover and space. Through a series of questions, arrive at the idea that food and cover are the most critical needs of pheasants—especially in winter. Help members identify the food and cover that make a complete habitat for ring-neck pheasants. Place all winter food and cover

specimens that were brought to the meeting on a table. Assign a number to each specimen. Have members write the correct name for each specimen and list the item as a food or as a cover plant or both. Allow the members a few minutes to identify the specimens. Then work with the group to compare their answers. Discuss each specimen's habitat role with the members. After the identification session divide the group into teams of three. This will be a time to learn how to build a winter habitat plan. Have each team sketch a design for providing a one acre winter habitat for ring-necked pheasants. Compare the various designs. (The "Questions to Ask" section has some valuable hints in preparing a good winter habitat plan.)

What 4-H'ers Will Do

4-H'ers will be able to:

1. Understand the relationship of winter habitat to healthy populations of ring-neck pheasants.
2. Recognize appropriate winter pheasant habitat plants.
3. Explore careers such as wildlife management, land management, forest resources, etc.

Questions to Ask

1. Where do ring-neck pheasants come from?

Answer: They were introduced from Asia in 1916.

2. What is their reproduction schedule?

Answer: Nesting may occur as early as mid-April. Egg laying peaks in mid-May. A hen takes 15 days to lay 10 eggs. Hatching occurs 23 days after incubation starts. Pheasants have one brood per year.

3. What is the most effect winter food for pheasants wherever it can be grown to maturity?

Answer: Corn.

4. What is an ideal food patch for an average farm trying to increase its pheasant habitat?

Answer: The ideal patch would include one to two acres of standing corn, sorghum, etc. adjacent to a cattail marsh, woodlot, windbreak or shelterbelt.

5. What are some other good sources of winter foods for pheasants?

Answer: Other good sources include soybeans, sorghum, sunflowers, flax, buckwheat, and small grains.

6. What are two essential requirements of food plots?

Answer: Two essential requirements are locating the patch less than 1/4 mile from good winter cover and maintaining food through the winter.

7. Where food plots are impractical, are there other alternatives?

Answer: Yes. Miniature cribs away from the wind (snow) made of hogwire can be filled with ear corn.

8. What is good winter cover for pheasants?

Answer: Good winter cover includes farm shelterbelts, multi-row field windbreaks, farm woodlots, cattail marshes, dense sorghum plantings and switchgrass plantings.

9. What are other benefits of planting shelterbelts and windbreaks?

Answer: They control soil erosion, conserve surface moisture, and reduce farm and home heating costs.

10. What types of species should be included in a shelterbelt/windbreak planting?

Answer: Include evergreens (red cedar, black hills, Norway, and white spruce) and bush plantings (wild plum, honeysuckle, and buffalo berry).

Supporting Activities

Develop a nesting plot using native warm season grass (switch grass is easy to plant). Roadsides along county or township roads make good areas; check with a local highway official first. Using the "Questions to Ask" session, hold a Pheasant Wildlife Bowl with the members. Teams of four will compete against each other. The first team member to raise his/her hand gets to answer the question. Give points for correct answers, subtract points for incorrect answers.

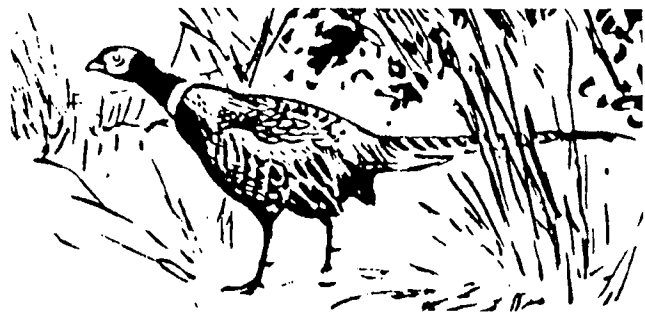

12. Practicing the Ten Commandments of Shooting Safety

Importance of the Topic

Learning the “ten commandments of shooting safety” is the highest priority in the Shooting Sports/Wildlife program. These principles must become so much a part of the members’ attitudes that they abide by them automatically. If this does not happen, shooting sports will not be a safe project.

Prepare for the Meeting

Adult and junior leaders must keep the ten commandments before the members at all times. Acquire printed copies and make

sure the members understand the importance of the commandments in the initial meeting. Instructors supervising shooting range activities should see that the commandments are strictly and consistently enforced whenever firearms are present.

Devote some time at each meeting to reviewing the commandments with the members and practicing the principles while shooting. Before the meeting, secure copies of the Ten Commandments of Shooting Safety, Minnesota Department of Natural Resources and PR Fed. Aid Project-W58S. If you are a DNR Firearms Safety Instructor, you can get the publication free through your local Game Law Enforcement Officer.

What 4-H’ers Will Do

4-H’ers will be able to:

1. Identify the ten commandments of shooting safety.
2. Apply these commandments to all group shooting activities within the project.
3. Become a safe shooter at all times, both on the shooting range and when hunting.
4. Learn to respect and abide by the “rules of life.”

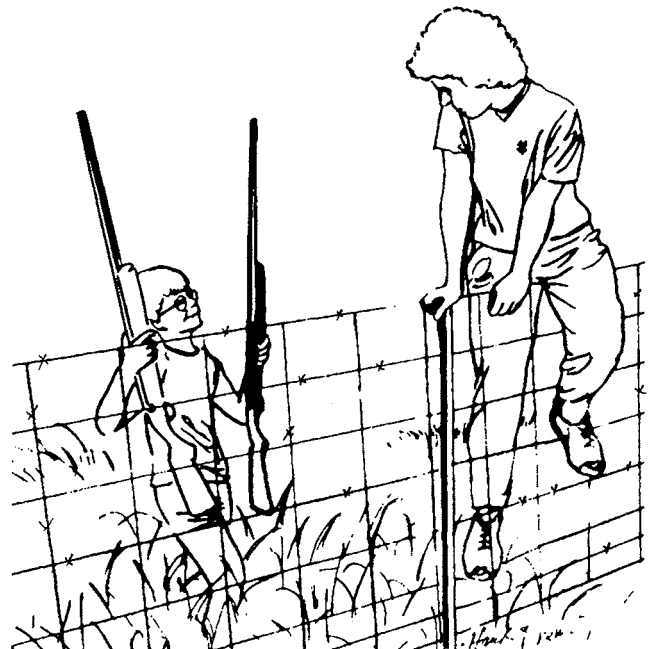

Involving the Members

To help each member learn the ten commandments of shooting safety, try some of the following activities:

- **Name on the Back:** Write each commandment on a slip of paper and pin or tape one to each person's back. Have members ask each other questions requiring a "yes" or "no" answer until everyone has figured out which of the commandments is on his or her back. Hints are all right if someone is really stuck.
- **Charades:** Divide into teams of two and have each team draw from a hat a piece of paper listing a commandment. Have each team act out the commandment to see how quickly the rest of the group can figure it out.
- **Demonstration:** Ask members to give a short demonstration on one or more of



the commandments at each meeting. You may want all members to then demonstrate how they would carry out the commandments presented.

With each activity you may want to encourage questions to help emphasize the importance of the commandment. See ideas under "Questions to Ask."

Give each member a copy of the Ten Commandments of Shooting Safety. Tell members that these principles will be strictly enforced during all of the project activities. Decide, as a group, the penalty for any violation. In this way all persons involved know what is required for a safe program and can help in monitoring and enforcement.

Review all ten shooting safety commandments during each activity or meeting until the members know them. Range instructors should look for infractions of the principles at all times and enforce the penalties fairly as determined by the group. In the early part of learning these principles, infractions are more common, but make penalties serious enough that the members learn the importance of the commandments. Make learning an active experience for youth; use games and role-playing whenever possible.

Questions to Ask

1. What would you do if you came across a hunter who has been drinking?

Answer: Report him or her to the area conservation officer.

2. What happens when you shoot at a hard, flat surface or water?

Answer: Bullets bounce off (ricochet) at unpredictable angles.

3. How would you feel if someone pointed a gun at you? Would you feel any better if you knew that the gun was empty or that the safety was engaged?

Answer: Unsafe, fearful, etc.

4. How do you know when the muzzle of your gun is pointed in a safe direction?

Answer: Never point a gun at an object you don't wish to shoot.

5. Why is it important to know your target and background?

Answer: So you don't shoot the wrong object, such as another human being or a protected animal.

6. How do you know you have the right ammunition for your firearm?

Answer: Information on caliber or gauge is stamped on the barrel of the gun and printed on the base of most cartridges.

7. How should you store guns and ammunition?

Answer: Locked up and in separate locations.

8. Compare climbing a tree or fence with a loaded gun vs. an unloaded one. How would you feel if you saw someone do it?

Answer: Never climb a tree or fence, or jump a ditch with a gun.

Supporting Activities

Display and enforce the safety commandments at all shooting activities, whether in the field or on the range.

Include project demonstrations of the ten commandments at your meetings. Ask youth to recall infractions that they have observed since the last meeting. Visit a shooting range and observe examples of appropriate and inappropriate behavior.

The ten commandments of shooting safety!

1. Always point the muzzle in a safe direction.
2. Treat every firearm as if it were loaded.
3. Unload firearms when not in use.
4. Be sure the barrel and action are clear and that you are using the proper ammunition for your firearm.
5. Be certain of your target before pulling the trigger.
6. Never point a firearm at anything you do not wish to shoot.
7. Never climb a tree or a fence, or jump a ditch, with a loaded firearm.
8. Never shoot at a flat, hard surface or water.
9. Store firearms and ammunition separately.
10. Avoid alcohol and other drugs before or during shooting.

13. Eye and Ear Protection

Importance of the Topic

A skilled hunter must have good vision and hearing. He or she must be able to spot game and detect sounds of approaching hunters or vehicles. Hunters also need to use adequate protection to avoid injuring their eyesight and hearing.

Prepare for the Meeting

Bring to the meeting a variety of ear and eye protectors. Most are inexpensive and can be found at any sporting goods store. Hearing equipment should include as many of the following protectors as possible: plug type, waxed cotton, rubber, silicone, and insulated muffs. For eye wear, include a variety of shock-resistant glasses in different shades and colors.

Bring a tape deck or radio that is capable of producing high volume. This will be used to illustrate the dampening effect of ear protectors.

Involving the Members

Hearing

Let the members examine the ear protectors you have brought to class. Briefly explain how each is used. (Most will include instructions.)

Next, using the tape deck, let the members experience high volumes of music with and without the various ear

protectors. Ask for their opinions on which types of protection are the most effective. Bring enough ear plugs that several students can do the exercise at one time.

If you can obtain a decibel meter, measure different sounds to help members understand how levels vary. Monitor normal conversation, loud music, and loud yelling.

What 4-H'ers Will Do

4-H'ers will be able to:

1. Learn about types and importance of eye protection.
2. Understand why they must be able to properly identify game animals and distinguish between types of animals (i.e., mallard duck versus pintail duck, etc.).
3. Understand the importance of hearing protection for range shooting, and learn about the types of hearing protection available.
4. Experiment with different sound sources and volumes to understand decibel levels.

Be sure to explain these following points:

1. The noise on a target range may be deafening...literally. Ear protection not only prevents hearing damage, but also makes it easier for you to concentrate while shooting.
2. Beware of the first sign of hearing stress--ringing in the ears. Protect against this by wearing hearing protection at all times on a firing range even if shooting alone or not shooting at all.
3. Some types of hearing protection are better than others. The plug type is inexpensive, and may reduce the noise by as much as 30 decibels, if inserted tightly enough to seal out sound. You would hear a 140-decibel noise at 110 decibels, a safer level. For maximum hearing protection, use muff-type hearing protectors with insulated, hard outer shells, the type you see heavy equipment operators or construction workers use.

Vision

Let the members examine the different types of eyewear that you have brought to

the meeting. Be sure to discuss these basic rules of sight protection and use of vision while hunting:

1. While hunting, always wear shooting glasses. They protect your eyes from debris as well as from brush.
2. Make sure the shooting glasses you choose have high-impact lenses. Yellow glasses may be unsafe to wear while hunting, since the yellow makes some shades of color look white, like the tail of a deer. Choose smoke, green, or brown tints for hunting.
3. Keep your eyes moving across your field of vision. This reduces eye fatigue and helps you to see objects at the sides, as well as directly in your line of sight.
4. If a hunter has "tunnel vision" and is unable to see movement to the left or right, he or she may accidentally injure someone who is near the line of fire. Remember, never fire at a target unless you are 100 percent sure of what you are shooting.
5. Knowing what to look for is as important as good vision and eye safety. You must learn about the different species of animals you hunt and how to identify them.



Questions to Ask

1. Under what conditions should the shooter wear protective glasses? Why?

Answer: Under all conditions. They will protect eyes from debris and gasses from gunfire, and from twigs snapping in thick brush.

2. Can you use prescription eye glasses as shooting glasses?

Answer: Yes. But only if they can withstand high impact without shattering. Your eye doctor can tell you if your lenses are impact-resistant.

3. Why is good vision important for hunting?

Answer: Because you must be able to identify your target and often distinguish one species or sex of animal from another. Also, you must be able to see beyond your target.

4. What does "decibel" mean?

Answer: A decibel is a unit used to measure the intensity of sound.

5. At what decibel level does permanent hearing damage occur, and what is the approximate decibel level of gunfire?

Answer: Hearing loss results from sound about 130 decibels or louder. Most gunfire exceeds 130 decibels.

6. How much will ear protectors reduce the decibel level?

Answer: About 30 decibels.

7. What types of ear protectors are available and which is best?

Answer: Plug type, waxed cotton, rubber plugs, silicone rubber plugs, and muff-type protectors. Insulated muffs offer the best protection.

Supporting Activities

Make a shopping list, and bring it to a sporting goods store. Compare brand names and costs of different types of ear and eye protection. Do the most expensive types offer the best protection? Talk to the sporting goods owner about the types of eye and ear protection he/she recommends.

14. Dressing For Hunter Safety

Importance of Topic

Proper attire is one of the most critical factors affecting the safety of a hunting experience. Dressing for safety includes choosing gear appropriate for weather conditions and wearing items that “flag” other hunters to your presence.

What 4-H’ers Will Do:

4-H’ers will be able to:

1. Be able to choose color-wise clothing appropriate to the hunting experience.
2. Understand hypothermia and recognize its symptoms.
3. Be able to dress appropriately for weather conditions.

hunting, such as boots, rain jackets, wool shirts, stocking hats, etc. These samples should include blaze orange/red colors, camouflage, and everyday color wear.

Involving the Members

Spread out the clothing on a table and give 4-H’ers individually the chance to “dress” (clothing should be put on over existing clothes, with the exception of shoes) for specific weather and hunting conditions. For example, you might assign a 4-H’er the task to dress for: Duck hunting at 36° F during a rainy, overcast day with chance of snow. Ask the rest of the 4-H’ers to constructively comment on each member’s choice of clothing, and lead the discussion to explain what the optimum clothing choice for each particular activity is. Make sure that the 4-H’ers understand when to choose blaze orange/red clothing and when to choose camouflage (see “Questions to Ask”).

Be sure to explain to the 4-H’ers what hypothermia is, and how it is a condition that can be minimized by proper attire and safety precautions.

Role play some of the symptoms of hypothermia. Let a 4-H’er pick a card. Have one act as the “victim,” exhibiting the symptom of hypothermia that they have drawn, and have the other 4-H’ers guess the symptoms. (For example, a person role playing “Poor Coordination” might say and act “Oh, I can’t seem to snap my coat, my fingers won’t work,” etc.). Rotate role

Prepare for the Meeting

You will need to bring to the meeting 10 or more index cards. Write the symptoms of hypothermia (see “Questions to Ask”) onto index cards, one symptom per index card.

You will also need to bring various samples of appropriate clothing for

players. Write the symptoms on the board as they are acted out. Be sure to review them with the group. Also discuss what to do in case of hypothermia, as suggested in "Questions to Ask." You might want to expand upon the role playing as above to get these concepts across.

Questions to Ask

1. When should you use camouflage clothing while hunting?

Answer: Bow hunters and small game (such as turkey) hunters will wear camouflage gear in the woods. When you wear camouflage clothing, you are attempting to blend in with your surroundings. This blending could be dangerous during shotgun/rifle big game hunting, when large objects moving through the woods are often mistaken for game, especially if their clothing blends in with the trees and brush.

2. What color clothing should I wear during white-tail deer hunting, or other big game hunting?

Answer: White-tail deer hunters should wear blaze orange/red outer wear and hats, in order to distinguish themselves from the game being hunted.

3. What is hypothermia?

Answer: Hypothermia is a physical condition that happens when you lose heat faster than your body can produce it. You are suffering from hypothermia if your body temperature drops below 95° F.

4. What is the difference between land and water hypothermia?

Answer: On land, hypothermia can take hours or even days to occur. In

cold water, hypothermia occurs very quickly. Both are influenced by age, weight, sex, physical and mental condition of the victim, outside temperature, activity level, etc.

5. What are the signs of hypothermia?

Answer: The symptoms, or signs, of hypothermia include:

- *Continual shivering*
- *Poor coordination*
- *Slowing down—inability to "keep up"*
- *Numb hands and feet*
- *Dazed and confused behavior*
- *Slurred or slowed speech*
- *Hallucinations*
- *Open (dilated) pupils*
- *Short attention span*
- *Changes in personality*

6. What should you do if someone you are hunting with shows these signs?

Answer: Follow these common rules:

- *Never leave the victim alone*
- *Don't transport the victim if aid can be brought in. Moving the victim increases the likelihood of shock and stress.*
- *Remove the victim's wet clothing gently and dress him or her in dry layers.*
- *Never give alcohol; but do give something warm and sweet to drink.*
- *Don't give medicine.*
- *Don't massage or jostle the victim.*
- *Shelter the victim from winds.*

7. What are some points to remember in dressing to stay warm and comfortable when planning to spend a day outdoors?

Answer: Common sense will dictate

much of your attire when you enter the outdoors. You must dress to keep yourself warm and dry. Dress in layers to stay warm and to be able to discard clothing if the temperature rises or activity makes you too warm. Wool keeps you warm and draws moisture away from the body, although it is a good idea to wear cotton undergarments as a barrier between your skin and a wool shirt. In cold climates, wear thermal underwear for added warmth. In extremely cold temperatures, wool pants or one-piece coveralls maintain your body temperature. Wear boots that are insulated and water resistant, a bill hat with ear flaps or a stocking

hat. Remember a jacket with a hooded sweatshirt that can be pulled up over your head for added warmth. And don't forget to wear high-quality insulated gloves.

Supporting Activities

Encourage the members to research hunter safety issues, including: the Armistice Day Blizzard (during which many hunters died of hypothermia); statistics on hunting accidents per state each year (tie into appropriate colored clothing); etc. Let the members present reports to the group about these issues.

15. Using a Map and Compass

Importance of the Topic

Most everyone knows that a compass needle points north and a map shows us where things are in our world. It takes an understanding of how to read a map and a compass to make them useful. It is critical that 4-H'ers be able to orient themselves in the outdoors so that they can find their way independently and safely.

Using a map and a compass together is a skill that can be learned by practice and can be useful throughout life.

What 4-H'ers Will Do

4-H'ers will be able to:

1. Learn the parts of a basic compass and an orienteering compass; learn the features of a map.
2. Learn how to take a bearing using compasses.
3. Learn how to use the compass and map together to chart a course.

Prepare for the Meeting

This guide is only an introduction. It is intended to be used indoors, using table space. It may be useful to plan two sessions to cover the material. If your group wishes to do further study outdoors, several educational resources are available, listed at the end of this booklet.

There are two types of compasses: the common compass and the orienteering¹ compass, which was developed to be used easily with a map.

1. Ask each member to bring a compass, one they own or can borrow. If possible, obtain at least one orienteering compass (available at camping and outfitting stores).
2. Make a photocopy of "Directions for Taking a Bearing" for each member.
3. Ask each member to bring a map, such as a road map.
4. Provide a 6" or a 12" ruler for each member to use with a map.

Involving the Members

1. Use "Introducing the Compass" (below) as a resource to discuss directions, how a compass is made, and how it works.
2. Use "Taking a Bearing" (below) to discuss bearings. Have each member practice taking several bearings.
3. Use "Introducing the Map" as a resource to discuss the parts of a map. Have

¹ORIENTEERING is registered trademark of Silva, a division of Johnson Camping, Inc. Box 966, Binghamton NY 13902 (607) 723-7546.

members discuss the parts of the maps they brought.

Introducing the Compass

On a compass, the painted half of the magnetic needle points NORTH. The perimeter of the compass housing is divided into 360 degrees. By convention, 0 (or 360) is called NORTH; 90, EAST; 180, SOUTH; 270, WEST. Be certain all members understand these conventions before trying to use the compass to take a bearing.

A bearing is the direction (in degrees) from a point (A) to a point (B). It does not tell how far it is from A to B.

Parts of a common compass

1. Magnetic needle—The “heart” of a compass, it is suspended inside a liquid-filling housing.
2. Scale—A circle around the perimeter of the housing, divided into 360 degrees.

Parts of an orienteering compass

1. Magnetic needle—A magnetized needle suspended inside a liquid-filled housing. The north half is painted red.
2. Housing—circular casing, made of clear plastic, and attached to the base so it can be rotated freely. On its rim are marked NESW and degrees. On the bottom are a red orienteering arrow pointing to the NORTH (0) on the housing and several parallel orienteering lines.
3. Base—rectangular, made of clear plastic. At one end are mounted the magnetic needle and its housing. From the housing rim to the end of the base runs a red line ending with an arrow. It is called the direction of travel arrow. The point on the line near the rim is marked “Read Bearing Here.”

Taking a Bearing

Common Compass

1. Stand at a point (A) and face (B).
2. Hold the compass flat in the palm of your hand near your chest so the needle swings freely.
3. Rotate the compass until the compass needle points directly at 0.
4. Read the degrees that are on the side away from you and on an imaginary line going from you to point (B).

Orienteering Compass

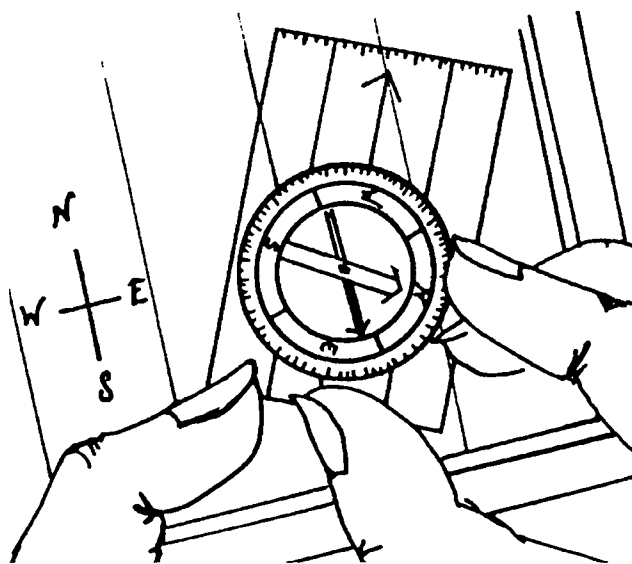

Orienteering Compass

1. Stand at point (A) and face (B).
2. Hold compass flat near your chest with direction of travel arrow pointing to (B).
3. Turn the compass housing until the orienteering arrow points the same direction as the compass magnetic needle.

4. You may now remove the compass from its flat position and read the bearing (direction) at the spot called "Read Bearing Here."

Introducing the Map

A map is a representation of land on a flat surface, usually a piece of paper. It shows the location of things much as they might appear from an airplane. Features of a map include:

1. Title—a short description of the area represented
2. The main map
3. Legend (or KEY)—a chart showing each symbol used on the map and a few words describing it. Colors also can be used as symbols, e.g., green for woods and blue for water.
4. Direction arrow—an indicator of which way is north. Usually it points to the top of the paper.
5. Scale—shows distance on the map in relation to the world. Example: 1 inch = 1 mile.

Most maps represent the earth as a flat plane with no indication of elevations of hills and valleys. These are called planimetric maps; a highway map is a good example. Topographic maps show elevations by using contour lines. A contour line shows all points on the map that are at the same elevation. A map made

for orienteering has several lines pointing the direction of magnetic north.

You can determine straight-line distances by measuring the length of a line between two points and then multiplying by the factor given on the map. For example, if the scale is 1 inch = 1 mile, then 3 inches on a map would represent 3 miles.

A compass can be used to find the direction from one point to another on a map. Use the same method given in the instructions for "Taking a Bearing." Use the north of the map as the reference base. When using a common compass, place the compass center over point (A) and rotate the map until the needle points to north on the map. When using the orienteering compass, lay it along the line from (A) to (B) with the direction of travel arrow pointing toward (B). Ignore the magnetic needle and rotate the housing until the orienteering arrow points north on map.

To go in a certain direction, set the degree number over the index pointer, point the direction-of-travel arrow straight ahead of you, orient the compass, and proceed.

Supporting Activities

Use the resources listed at the end of this book to teach the members more about orienteering. Practice running pre-set orienteering courses outdoors, using activities suggested in the references.

16. Identifying Types, Parts, and Functions of Firearms

Importance Of the Topic

It's important for 4-H'ers to know the different types of firearms, to match them to specific tasks. Rifles and handguns are suited to precision shooting, while the shotgun is a non-precision firearm designed for use with moving targets. The musket, a transition firearm, was more versatile. It could fire either a ball or a number of small projectiles for defense or hunting.

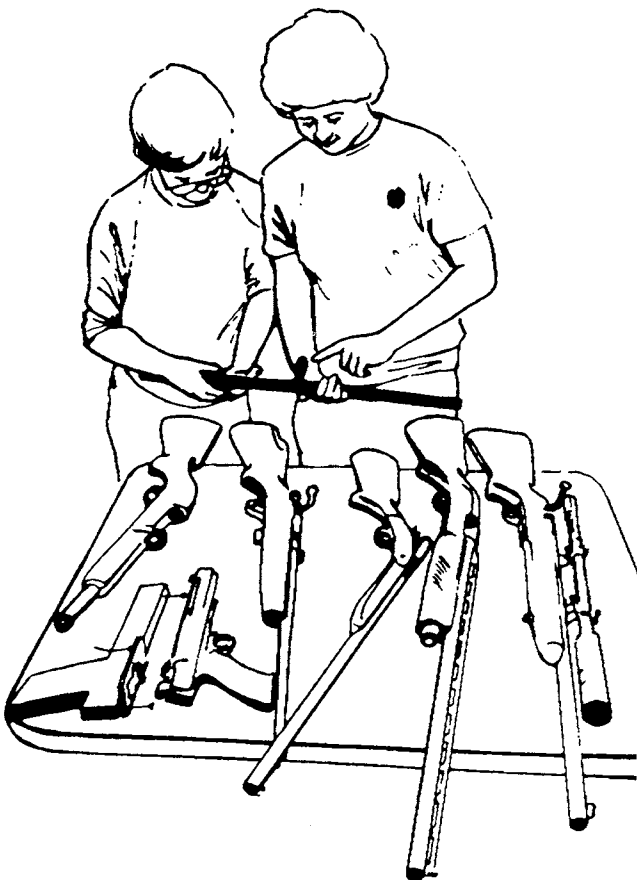

What 4-H'ers Will Do

4-H'ers will be able to:

1. Identify the four basic types of firearms: rifle, shotgun, muzzleloader, and handgun.
2. Research some of the history and identify uses and limitations of each firearm.
3. Learn the basic grouping of parts.
4. Identify the four types of shotgun actions, five types of rifle actions, two basic types of muzzleloader actions, and four types of handgun actions.

Prepare for the Meeting

Involve your junior leaders in planning this project meeting. Ask each junior leader to help prepare a demonstration on the history, uses, and action types of one of the four types of firearms. The junior leaders can illustrate the types of actions by giving a demonstration using pictures or actual examples of each of the following:

- Shotgun: pump action, semi-automatic action, bolt action, break action.
- Rifle: bolt action, semi-automatic action, lever action, pump action, and break action.

- Muzzleloader: flintlock, percussion cap.
- Handgun: break action, semi-automatic, single-action revolver, and double-action revolver.

Involving the Members

Place on tables the pictures or samples the junior leaders and/or members have gathered and ask the 4-H'ers to see how many samples they can correctly identify. Provide a set of answer cards at each station. For example, at the shotguns station, teams of two or three would attempt to match a card listing one of the four shotgun action types with the picture or actual guns. Include a picture on the back of the card or a letter corresponding to

Common Rifle Actions

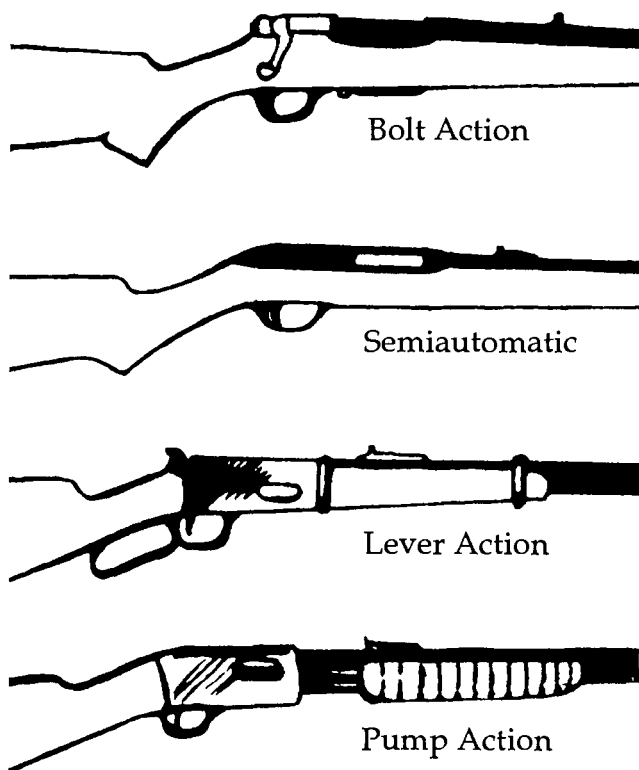

the one assigned to the shotgun so the members can check their answers.

Junior leaders and adults can reinforce the experience at each table or station by asking questions and encouraging discussion. After all members have had a chance to test their knowledge, hold up a firearm and ask youth to identify the three basic parts: action (lock), stock (frame), and the barrel. Then have them explain the purpose of each part:

- **Action:** The action is where the stock and barrel are attached. It contains all functional parts that load, fire, and eject.
- **Stock or Frame:** A handle or support for the action.
- **Barrel:** A metal tube through which the projectile passes. It supports a front and rear sight.

Next, junior leaders might give a demonstration on shotguns, rifles, muzzleloaders, and handguns. Allow time for questions. Bring up uses, types of actions, advantages, and disadvantages of each type. List them on a flip chart or a blackboard.

- **Shotgun:** designed to enable shooter to hit moving targets--short range but large pattern. Uses: sport hunting, club, law enforcement. Gauges: 10, 12, 16, 20, 28, .410 (caliber)
- **Rifle:** highly accurate. Uses: sport hunting, club, military use, law enforcement.
- **Muzzleloader:** large pattern. Uses: sport hunting.
- **Handgun:** designed for short-distance shooting. Uses: club, military use, law enforcement. Let each junior leader hold up one type of firearm and ask the members to call out the basic type, type

of action, and benefits and limitations. Use the questions and answers to summarize, if you wish. Let the junior

leaders ask the 4-H'ers what type of firearms they would use for a specific situation, such as hunting across broad expanses of range at non-moving targets.

Common Handguns

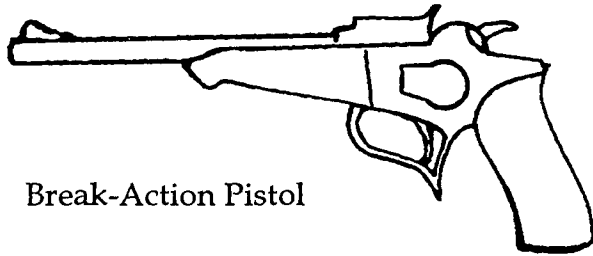

Break-Action Pistol

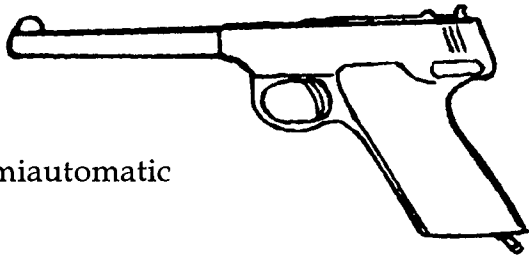

Semiautomatic

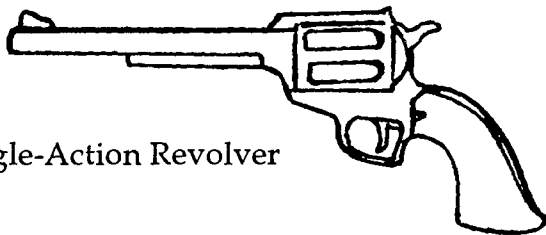

Single-Action Revolver



Double-Action Revolver

Questions to Ask

1. What is the difference between a pump and break action shotgun?
Answer: A pump action has a fixed barrel, and a break is hinged with open action to load.
2. What are common rifle actions?
Answer: A bolt, semiautomatic, lever and pump action.
3. What are examples of common shotgun actions?
Answer: Pump, semi-automatic, bolt, and break-action.
4. Name some common handguns.
Answer: A break-action pistol, semiautomatic, single-action revolver, and double-action revolver.

Supporting Activities

Attend a firearms show and talk with exhibitors. Have local police officers discuss their equipment, including their firearms. Invite a national guardsperson or member of a reserve unit to your club meeting to talk about use of military firearms.

17. Identifying Parts and Functions of Ammunition

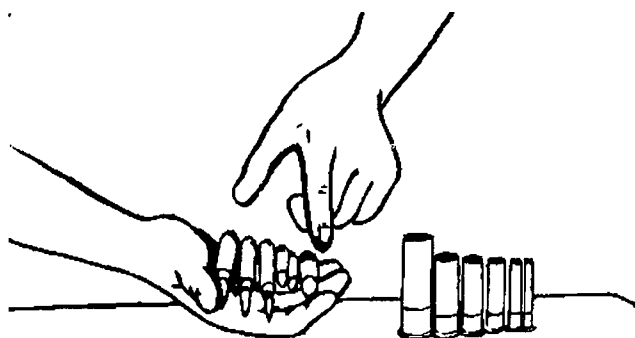

Importance of Topic

Members must be able to identify ammunition and understand its uses in order to use it safely and correctly.

What 4-H'ers Will Do

4-H'ers will be able to:

1. Identify the four basic parts of ammunition (five, in the case of shotgun) and understand the function of each.
2. Recognize three types of sporting ammunition and when to use each.
3. Discuss the difference between rim-fire and center-fire ammunition.
4. Gain self-confidence in teaching these principles to others.

Prepare for the Meeting

Meet with one or more of your junior leaders in advance to plan how to present the lesson and who will be responsible for each activity. Gather dummy samples of ammunition.

Involving the Members

Make a meeting a learn-by-doing experience. Several activities may be used to get everyone involved.

1. Let the members handle various types of dummy ammunition and discover the basic similarities and differences. You might also want to use large-scale drawings based on the one included in this guide.
2. Let the members draw figures (on a chalkboard or flip chart) similar to those in the illustrations in this unit, labeling the parts of ammunition correctly.

One junior leader can demonstrate, through discovery, the basic parts of the ammunition: primer, case, powder charge, projectile (bullet or shot) and (for shotgun) the wadding, as well as the function of each. Another junior leader can demonstrate the three types of sporting ammunition (center-fire and rim-fire cartridges and shotgun shells) and when to use each.

To summarize the activity, review the parts of ammunition using the three illustrations.

Questions to Ask

1. What is the difference between rim-fire and center-fire cartridges?

Answer: Location of the primer.

2. Is a shotgun shell center fire or rim fire?

Answer: Center fire

3. What are the basic parts of ammunition?

Answer: Primer, case, projectile (bullet or shot), and powder charge (also wadding for shotgun).

4. What is the case and what does it do?

Answer: For cartridges, the case is a brass or steel cylinder. For shotgun shells, the case is plastic or paper

cylinder. The case is closed at one end and contains the other components. It has a rim that positions it in the chamber.

5. What is the purpose of the primer?

Answer: The primer contains a very sensitive explosive compound. When struck, the compound changes chemical structure and disintegrates, igniting the powder charge.

6. What is the purpose of the powder charge?

Answer: The powder charge burns when ignited by the explosion of the primer. The burning creates great quantities of rapidly expanding gas, which push the projectile from the barrel.

1. Bullet
2. Case
3. Powder
4. Primer
5. Shot
6. Wad

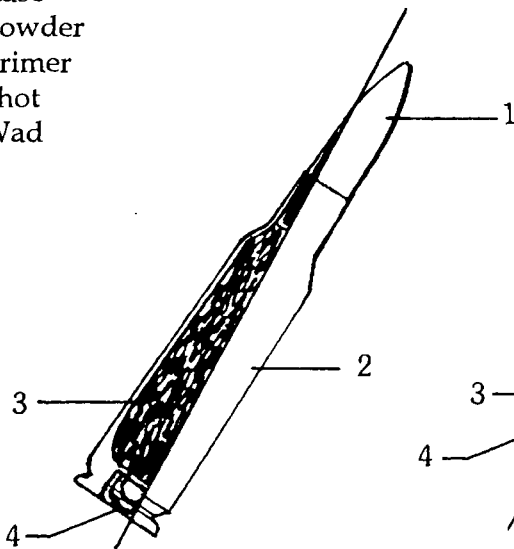

Center-Fire Cartridge Shell

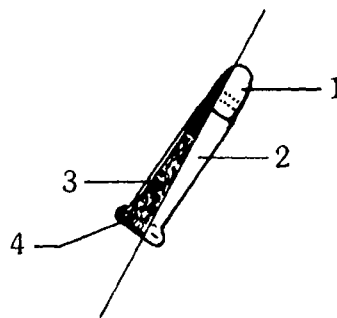

Rim-Fire Cartridge

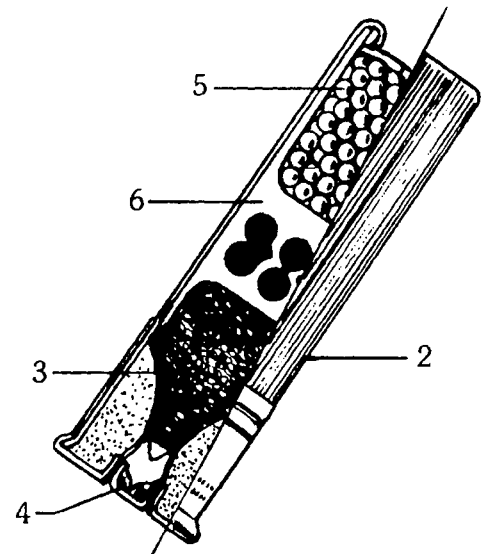

Shotgun Shell

7. Describe the projectile (bullet or shot).

Answer: The bullet (the projectile in the case of a cartridge) is made of lead or lead jacketed with a harder metal. The shot (in the case of a shotgun shell) is made of steel, lead, or copper-plated lead.

8. What does "gauge" mean? What are the various gauges of shotgun shells? What is caliber?

Answer: The gauge equals the number of lead balls the diameter of the opening of a shotgun barrel that it would take to equal one pound. For example, 20 lead balls the size of a 20 gauge barrel opening weigh one

pound. The most popular gauges are 20 and 12. The .410 is not a gauge but a caliber. Caliber is measured in millimeters or inches. .22-caliber is .22 inches; a 30-06, .30 inches; and a 7 mm, 7 mm (about .270 inches).

Supporting Activities

Tour a sporting goods store or invite the owner to your group to give a presentation on parts and functions of ammunition. Research the history of ammunition and its role in different civilizations, or prepare an exhibit of different parts and functions of ammunition.

18. Identifying Types, Parts, and Functions of Bows

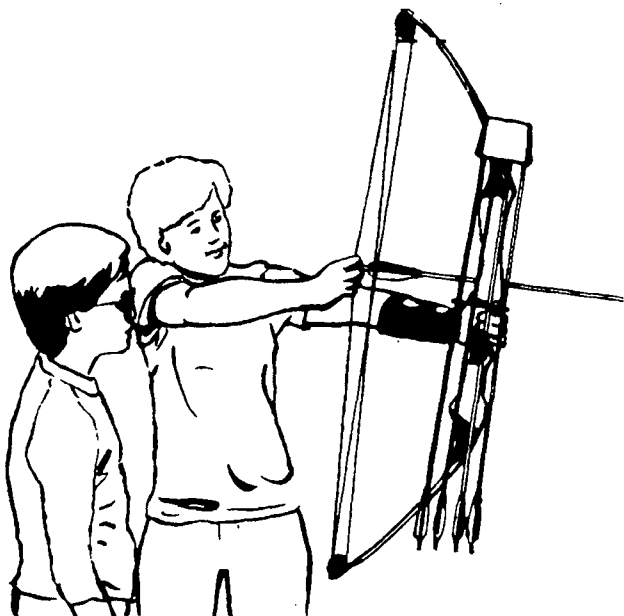

What 4-H'ers Will Do

4-H'ers will be able to:

1. Recognize single curve, re-curve, and compound bows and crossbows.
2. Research the general history of the bow.
3. Identify the 13 basic parts and functions of the recurve bow and the 11 basic parts and functions of the compound bow.
4. Test both bows to determine which best fits their needs.

Importance of the Topic

There are two types of bows--crossbows and longbows. Crossbows generally are not legal to use for hunting. The longbow, the only one used in this project, has three types: single curves, recurves, and compound bows. To select the best bow for your sporting use, you need to know how each bow is used, some of its history, and its advantages and disadvantages.

Prepare for the Meeting

Involve junior leaders in planning meetings and gathering needed supplies, including:

1. Samples of recurve and compound bows.
2. Samples or pictures of a single curve bow and a crossbow.
3. Posters or pictures of recurve and compound bows.
4. Small pieces of paper or cards labeled with the parts of bows.
5. Tape or pins.

Involving the Members

Divide the members into two groups, giving each a different bow, pieces of paper with the parts written on them, and tape. Have them identify the three major parts of

the bows (limb, riser, and strings) and tape the names to the bow. Do the same for the parts within each major group. Have the groups exchange bows and repeat the exercise. As a concluding exercise on identification of parts, point to various parts of the bows and ask the name of the part and its function.

Allow members to handle bows and have them explain which type they prefer and why. You may want to use posters with stick-on labels for parts to reinforce the learning.

NOTE: Do not dry fire bows. This can injure participants and damage the bow.

Recurve Bow

Compound Bow

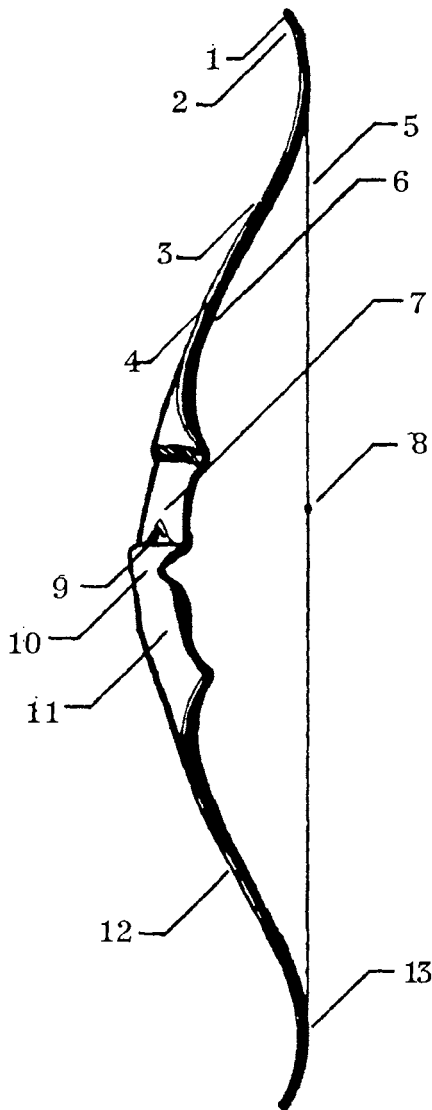

1. Tip
2. String nock
3. Upper limb
4. Back
5. String
6. Face
7. Sight Window
8. Nocking point
9. Arrow plate and rest
10. Pivot Point
11. Grip
12. Lower limb
13. Recurve
14. Limb bolt
15. Handle or riser section
16. Cable anchor
17. Eccentric
18. Eccentric hanger bracket

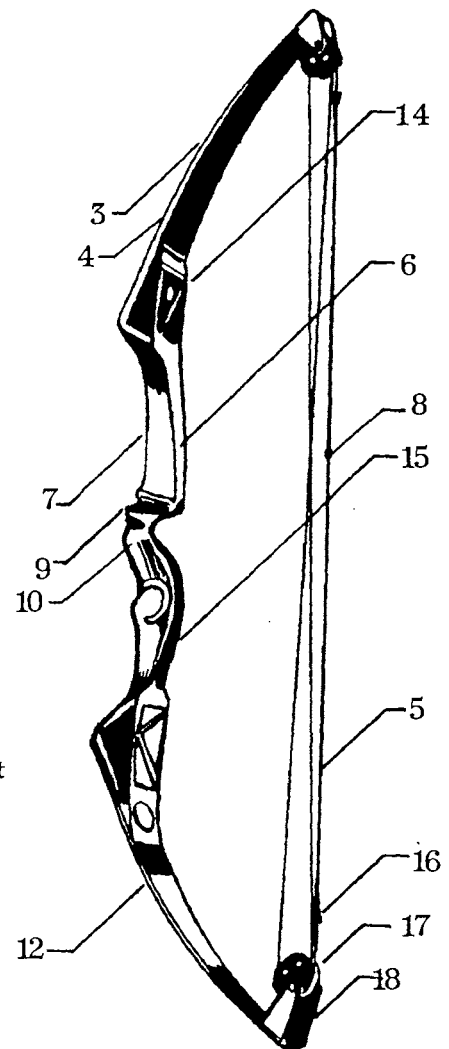

Questions to Ask

1. Is the bow a relatively new invention?

Answer: No. Flint points date back about 50,000 years. New types of bows have been developed recently, however.

2. Why didn't native Australians use a bow?

Answer: They used boomerangs.

3. How many basic parts does a bow have?

Answer: Three: limb, riser, and string.

4. How many parts are common to recurve and compound bows?

Answer: Ten (see the illustrations on the previous page).

5. How many are different?

Answer: Eight (see illustration).

Supporting Activities

Have members research and report the history of bows. They will find that bows are among the oldest and most used weapons and were found in every country except Australia. Flint arrowheads have been found that date back 25,000 to 50,000 years.

Tour a sporting goods store or study a catalog to find the best archery equipment, in terms of cost and quality.

19. Identifying Parts and Functions of Arrows

Importance of the Topic

An arrow, just like any kind of ammunition, must be understood in order to be used safely and effectively.



What 4-H'ers Will Do

4-H'ers will be able to:

1. Identify the individual parts of an arrow and understand the function of each.
2. Select proper arrow size.
3. Gain self-confidence in teaching others.

Prepare for the Meeting

Meet with one or more of your junior leaders in advance and plan how they will be involved. Find an arrow that can be disassembled or examples of different kinds of arrows. If arrows are not available, draw picture(s) on a large sheet of paper or on a blackboard. Help your junior leader present parts or all of the lesson; help your presenters be successful.

Involving the Members

If you have examples of arrows at your meeting, hand them out and allow the members to look at them. Allow them to discover any differences between the arrows. Talk about why there are such differences.

Allow members to find an arrow that fits their arm length. A simple method is to have the archer hold an arrow with the nock touching the center of his or her breast bone, then extend both arms forward and touch fingertips. A target arrow of the proper length will extend to the fingertips. A hunting arrow, which is longer, should extend approximately one inch beyond the finger tips.

To summarize the activity, review the parts of the arrow, the function of each part, safe handling practices, and proper fitting of the arrow to the bow hunter.

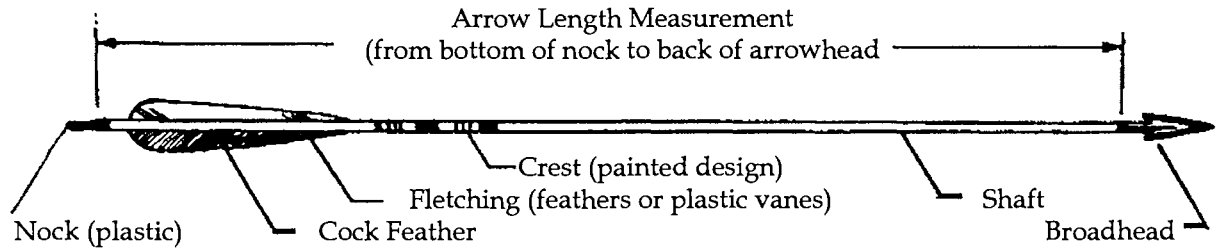

Questions to Ask

1. What are the six parts of an arrow?

Answer: Nock, cock feather, fletching, crest, shaft, and point.

2. Describe each part and its function.

Answer: Nock--slot in the shaft where the bowstring fits.

Cock feather--the odd-colored feather, on a 3-fletched arrow; used as reference in nocking arrow so fletching does not impact bow riser and deflect arrow.

Fletching--plastic vanes or feathers, three to six on shaft, that help the arrow fly straight.

Crest--painted design to identify owner of arrow.

Shaft--can be wood, fiberglass, lightweight metal, or graphite.

Point--matched to the arrow use (target for field shooting; broadhead for hunting big game; blunt for hunting small game, etc.).

3. What are some variations in fletchings?

Answer: Fletchings may vary in the material (feathers or plastic vanes),

number per shaft, and length. Flu-flu fletching, which looks like a bottle brush, is used to limit the distance an arrow will travel. Sometimes the fletching is slightly spiraled to gain more fletching length without using additional shaft.

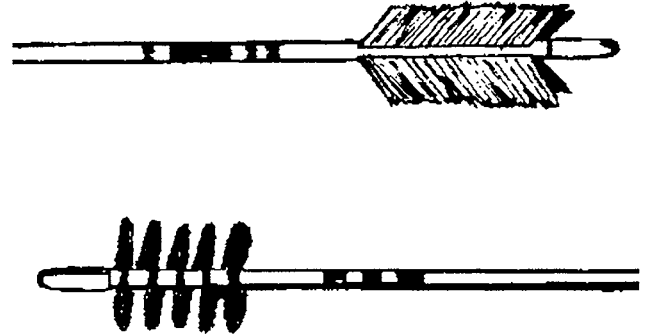

Flu-flu Fletchings

4. What are some safety practices to use with arrows?

Answer: Examine arrows for cracks, bends, or breaks in the shaft before shooting. Arrows with cracked shafts should be destroyed and discarded, because they can break as they leave the bow, injuring the archer or observers. Check the nock. Replace damaged nocks.

5. What are some different kinds of broadheads and their uses?

Answer: Many types of broadheads are used, depending on the game hunted. Broadheads must be razor sharp to be effective. Some have a razor blade or scalpel-type insert. Some broadheads can be bought sharpened and ready for use; others need to be sharpened by the hunter.

6. What are some other kinds of arrow points and their uses?

Answer: Blunt (for hunting small game), target and field (for marksmanship).

Supporting Activities

1. Tour an archery supply store.
2. Practice shooting different kinds of arrows.
3. Show how an arrow becomes less useful with any parts missing.
4. Research the history of arrows and their role in the development of different civilizations.
5. Make a simple arrow out of a dowel and bird feathers, carved nock and flint head.
6. Prepare an exhibit of modern and old arrows.

20. Determining Dominant Eye

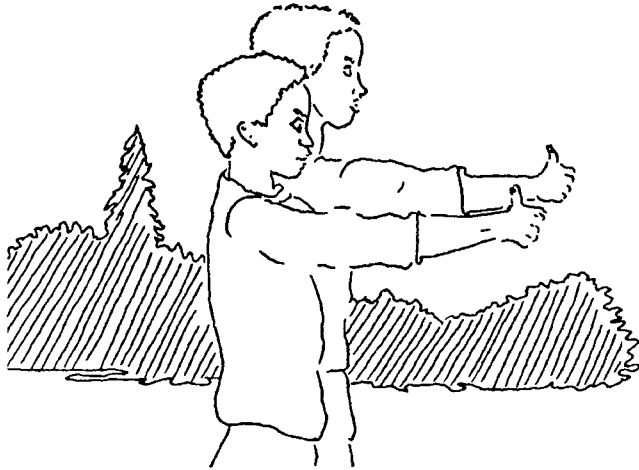

help switch eye dominance, since they have greater difficulty in shooting successfully.

Involving the Members

1. Let members focus on an object 10 to 40 feet away, raise one hand (arm extended) to eye level, and make a fist with a "thumbs-up" sign. Ask them, with both eyes open, to sight along the top of the thumb to the object. Now let them close

Importance of the Topic

Shooting is most successful and relaxed when the shooter is aiming with the dominant eye. This guide will help the members determine their dominant eye.

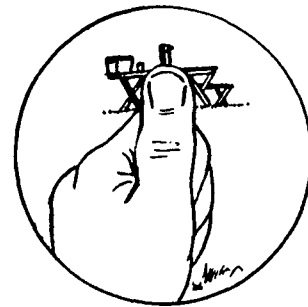

Prepare for the Meeting

Read through the guide and practice the exercises ahead of time. The total time needed may be as little as 15 minutes, so you may want to plan some marksmanship activities for the same meeting.

Before beginning, be sure each member has adequate natural or corrected vision. Remember the old saying, "If you can't see it, you won't hit it."

Difficulties can occur when a right-handed member has a dominant left eye or vice versa. This is called cross dominance. Cross-dominant shooters may need special exercises (provided by an eye specialist) to

one eye and tell whether the object changed. If not, have them open both

What 4-H'ers Will Do

4-H'ers will be able to:

1. Identify and use the dominant eye for shooting or archery.
2. Learn some techniques for correcting cross-dominance problems.

eyes and then close the other eye. The object will appear to jump to the side when viewed with the non-dominant eye.

2. To double check eye dominance, let members focus on a small object 10 to 40 feet in the distance. Next, have them overlap their hands so only a small hole (1 inch maximum) exists between hands above crossed thumbs (see below).

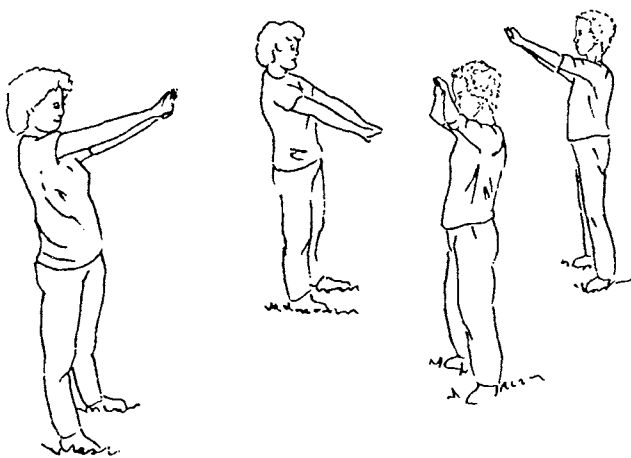

Let the members slowly raise their hands, keeping arms extended, and look through the hole (with both eyes open) towards the object. They should slowly bring their hands back toward their faces. The members will automatically move their hands to align the hole with dominant eye.

Questions to Ask

1. Why do shooters benefit from having both eyes open?
Answer: The dominant eye focuses directly on an object (front sight) while the non-dominant eye senses other information such as relative size

of target, relative location, body orientation to the intended target, distance from the target, etc. In trap, skeet, or field hunting it will help determine how much lead to use.

2. What if I can't keep both eyes open when I shoot?
Answer: This is generally not a problem. Shoot with one eye open but shoulder the rifle or shotgun to correspond with your "shooting" eye: right eye open, shoot right handed; left eye open, shoot left handed.
3. What if I can't close one eye and I see multiple images?
Answer: Use an eye patch or tape to block out the vision of the non-dominant eye (see below). Be sure to apply the tape or patch between the person's eye and the lens.

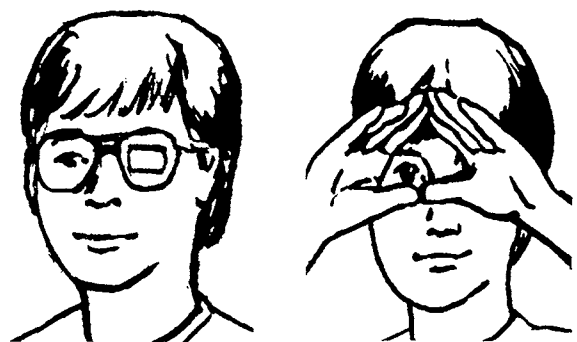

4. Does eye dominance make a difference in archery or pistol shooting?
Answer: Yes. Eye dominance is important in both, but especially in archery. Use the same rules in archery as you use for shotgun/rifle. In pistol shooting, eye dominance may be important when using a one-hand

hold, but the two-hand hold is very flexible, so eye dominance is of no consequence.

5. If neither eye is dominant, how do I know which to use in shooting?

Answer: Close your eyes and have an instructor help you shoulder a rifle or shotgun. Try both right and left-hand holds. Use the position that feels most comfortable. Archers and pistol

shooters may use the stronger arm for drawing the bow or holding the handgun. Block out the vision in the "off" eye with tape or a patch when you shoot.

Supporting Activities

Invite an eye doctor to discuss eye dominance with club members.

21. Fitting the Shotgun or Rifle

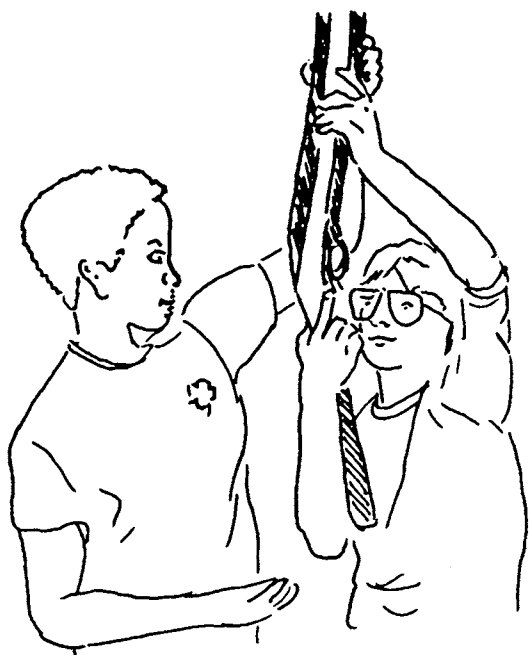

Importance of the Topic

A properly fitted shotgun or rifle will enable the member to shoot more accurately, comfortably, and safely.

Prepare for the Meeting

Have members bring the firearm they plan to use. If a gunsmith is available, ask him or her to prepare a short talk or demonstration on how a firearm is fitted to an individual.

Work with the junior leaders ahead of time, making sure they understand how to determine a correct fit. This will make them feel comfortable helping the 4-H'ers during the meeting.

Involving the Members

Divide the members into teams of two or three and give them the following situation and task to accomplish:

- Situation: You are looking for a new firearm in a store and want to find one that fits you correctly.
- Your Task: Prepare and give a short demonstration on how you will determine whether the gun you have selected:
 - Has the proper length of pull.
 - Allows you to keep your head erect.
 - Is the proper weight, length, and balance.

(You may want to give each team just one of these items to demonstrate.)

What 4-H'ers Will Do

4-H'ers will be able to:

1. Determine the proper fit for their guns.
2. Show others why their gun is or is not properly fitted.
3. Become safer shooters and gain more enjoyment from the sport.

Allow the teams time to discover what they know or don't know about the proper fit of a firearm. Then, with your junior leaders, move from team to team providing support and hints through questions on how to accomplish the task.

As the teams give their presentations, encourage everyone to ask questions; several are included in this guide. What would each member do if some aspect of their gun was not fitted properly? Can their firearm be customized, and if so, how is this done?

To summarize the meeting, describe the important points to consider when fitting a shotgun or rifle. Discuss various methods to inexpensively alter the fit and how fit effects shooting success. Stress safety aspects; all private firearms should be certified by a gunsmith before they are used in club activities.

Questions to Ask

1. How do you determine proper length of pull?

Answer: Place the butt inside your elbow and point the firearm up. Close

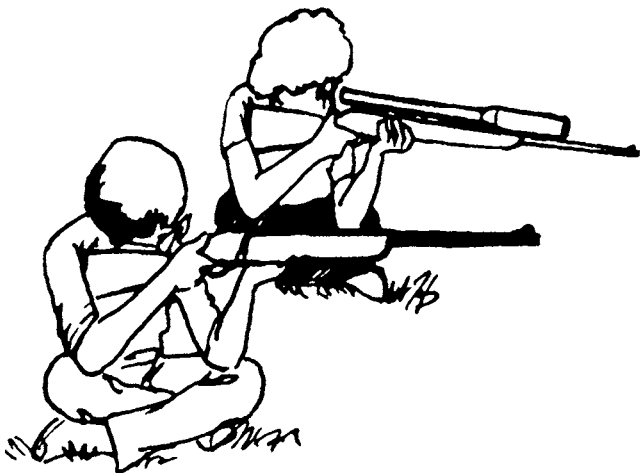

your forearm along the stock. The first joint of your trigger finger should rest alongside the trigger.

2. How do you verify that the gun allows the head to be kept erect?

Answer: Raise your shooting arm to your shoulder and place butt of stock into the pocket of your shoulder. Place your cheek against the stock. You should be able to keep your head erect. This gives a wide clear view of the target and a good sight picture. It also reduces fatigue and helps keep you from lifting your head from the stock. If the drop at the gun's heel fits and the grip feels right but your head is too low, you may need a Monte Carlo type stock (which raises the height of the comb) to raise your head position. Comfort is important.

3. How can you tell if the weight, length, and balance are correct?

Answer: The fit is not good if, when the firearm is held in position, the extended hand supporting it is too far forward to help hold up the barrel. A shorter barrel or youth model may be needed. Good balance means being able to hold the firearm easily without having to lean too far forward or backward to compensate for its weight.

4. What are some ways firearms can be custom fit?

Answer: Some firearms can be custom fit by shortening or lengthening the stock, or by changing the barrel length. This is especially easy with shotguns having interchangeable barrels.

5. Why is proper fit important?

Answer: Proper fit provides less physical stress, better control, and is safer.

6. Are special tools needed to fit a firearm?

Answer: Sometimes custom-fit models require expensive equipment, but most firearms can be fit with a wood rasp, good miter saw, hand drill, and a screwdriver. A professional gunsmith can demonstrate these techniques.

7. What fitting equipment is commonly used?

Answer: Common fitting equipment includes check rods, butt plates, and recoil pads.

Supporting Activities

Invite a gunsmith to demonstrate how firearms can be altered for fit. Members can research the fitting equipment (check rods, butt plates, recoil pads, etc.), and present this information at a club meeting.

22. Practicing Aiming Techniques and Trigger Control



Importance of the Topic

To shoot accurately, the shooter needs strong concentration and good hand-eye coordination. The 4-H'ers need some pointers on how to develop their aiming techniques and trigger control.

Once the 4-H'ers have determined their dominant eye, the next step is to learn proper aiming techniques: sight alignment, trigger control, and sight picture. Aiming techniques include four elements: the dominant eye, rear sight, front sight, and the impact area. Shooters must be able to aim properly to insure accuracy in their marksmanship.

Prepare for the Meeting

For every two students, provide one air pistol, air pellet rifle, or single-shot bolt

action .22-caliber rifle. Prepare a shooting bench and sandbags, targets, target traps, and ammunition. Pictures or charts of rear sights, front sights, sight alignment, and sight picture will be helpful. Each member will need ear and eye protection. If you use air rifles, make target boxes to set up an indoor or outdoor range. This is a good introductory lesson for juniors to present. Meet with them in advance to plan their involvement.

Involving the Members

Before the members actually begin aiming, they should have a basic understanding of types of rear sights and

What 4-H'ers Will Do

4-H'ers will be able to:

1. Learn and practice physical control, eye-hand coordination, and ability to concentrate on the task at hand.
2. Learn to recognize the types of front and rear sights.
3. Learn the aiming process, including proper use of sight alignment, trigger control, and sight picture to fire a successful shot.

front sights, proper sight alignment, sight picture, and trigger pull. Be sure leaders keep the members involved by asking questions before giving answers. Charts and examples are very helpful.

Sights: Have members draw the rear and front sights they are familiar with. Follow this up by matching names to the various sights, as illustrated below.

Rear Sights



Peep Sight



Notch



V-type



U-type

Open Sights

Front Sights



Post



Post-Bead



Aperture



Aperture-Post



Aperture Bead



Aperture Point of Aim

Ideal aperture is 1.1 to 1.3 mm (.044 to .052 inch).

Sight alignment and sight picture: After providing a brief background on types of front and rear sights, find out what the members know about proper sight alignment and sight picture. On the top half of an 8-1/2 by 11" sheet of paper, have each member or team of two draw a picture of what they believe is a proper sight alignment; have them draw a proper sight picture on the bottom half. Have each

person or team explain to another member or junior leader what they have drawn.

Follow this exercise with charts or use the members' examples of sight alignment and sight picture. See "Questions to Ask" for definitions.

Use an open rear sight and a post front sight for your example before introducing peep and aperture sights.

Correct Sight Alignment With Open Sights



Correct Sight Picture With Open Sights



Trigger control: Give a junior leader the opportunity to emphasize and demonstrate the following rules and examples of trigger control. It might be helpful to first poll the 4-H'ers to find out what they understand about proper techniques.

1. Squeeze the trigger while you are holding steady.
2. Squeeze the trigger smoothly straight back without disturbing your sight alignment.

3. For pistol shooting, grasp the grip firmly as in a handshake. The top part of the index finger just above the first joint should rest on the trigger. Your finger must press straight back on the trigger.

Shooting for groupings: Pair a coach and a student (younger member/junior leader would be a good idea) at each firing point. A range commander controls the safety and instruction on the line.

The best way to begin practicing trigger control/sight alignment is by dry-firing (shooting without ammunition). Put up a piece of blank paper or reverse a target and shoot using a cocked but unloaded air pistol. Follow all safety rules. Have the members practice trigger control by dry-firing several shots. Concentrate their attention on sight alignment as they pull the trigger. (Note: BB guns and some air rifles cannot be dry-fired. Daisy 853 rifles and Daisy 717 and Crosman air pistols can be dry-fired).

When the students have mastered dry-firing (sight alignment and trigger control), have them fire three to five rounds still using the paper target. Remember to use correct range commands during this procedure. They should have a shot group or pattern. If not, shoot another set of three to five rounds. By then there should be a definite shot group.

Next, move the shot group to the center of the piece of paper by moving the rear sight in the direction you want the shot group to move. This is sight adjustment. Verify this by shooting another set of three to five rounds.

Last is a sight picture. Turn the target around and let them fire at the bullseye. If some members have persistent problems achieving success, work with them individually at a later time.

Rear Sight Should Move in Same Direction Shooter Wants to Move Group

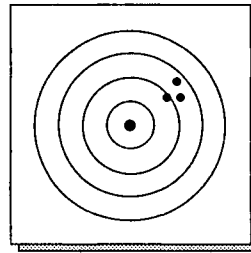

Definite Shot Group

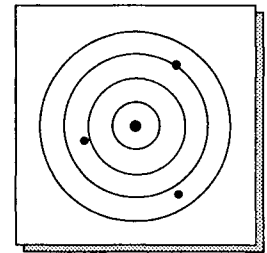

Indefinite Shot Group

Questions to Ask

1. What four elements need to be lined up to aim properly?

Answer: The dominant eye, rear sight, front sight, and impact area.

2. What is sight alignment?

Answer: The relationship between the front and rear sights.

3. What is sight picture?

Answer: The relationship between the aligned sights and the aiming bull on the target.

4. What does follow through mean?

Answer: To continue aiming until after the shot is fired. It assures that you are continuing to hold steady until well after the bullet has left the barrel: that you are maintaining concentration.

Supporting Activities

The NRA film *Rifle Shooting Fundamentals: Firing the Shot* (4H-FM-2484) and the Minnesota 4-H videotape *Shooting FUNDamentals* (4H-VH-3309) are available from the MES Distribution Center or your county extension agent.

23. Stalking and Still Hunting

Importance of the Topic

Photography, hunting, or simple observation are all ways of getting close to wildlife and enjoying nature. Stalking and still hunting techniques will enable you to observe many wildlife species. These skills require self-control and an understanding of wildlife ecology.

Prepare for the Meeting

Help the junior leaders prepare for the meeting. Encourage them to learn more about the topic and to brainstorm ideas and think of props that will help convey subjects to the 4-H'ers.

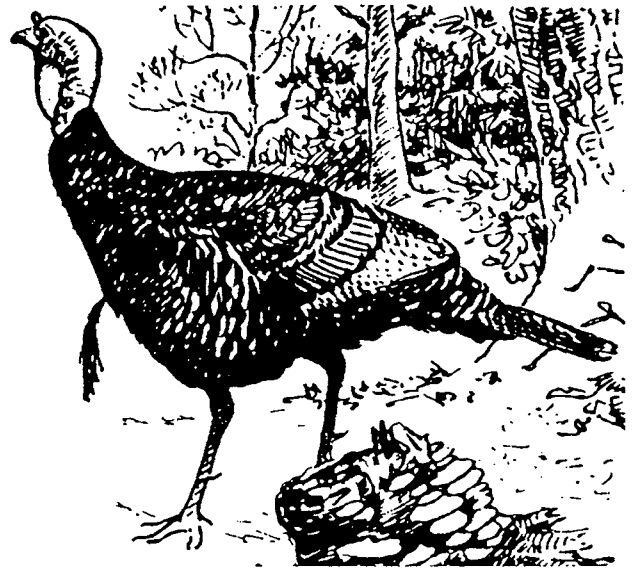

You will need to bring eggshells, peanut shells, or styrofoam peanuts to the meeting to spread on the floor in order to practice quiet movement.

The activity on trained eyesight is best suited to an outdoor location. Arrange to visit an area which has visible signs of game activity, such as droppings, tracks, appropriate habitat, etc.

Involving the Members

Start with a brief discussion of the topics. You or the junior leaders should introduce the basic ideas behind stalking and still hunting, and when they are useful. Be sure to cover basic definitions:

1. Stalking is the slow, silent pursuit of an animal to get close enough to get a good photograph, shot, or just a good look at

What 4-H'ers Will Do

4-H'ers will be able to:

1. Learn the principles of stalking and still hunting.
2. Discuss and practice the skills necessary for successful still hunting and stalking, including physical conditioning, concentration, trained eyesight, trained hearing, and environmental assessment.

an animal. A crouched position (bent over) is the best for pursuing animals because it is less noticeable. In this position the "hunter" walks quietly and slowly, pursuing animals of interest.

2. Still hunting is the continuous movement of a hunter through an animal's environment in hopes of finding desired game. By walking and standing silently the hunter is less likely to be observed by animals.

Stalking and still hunting techniques are learned and improved by study and practice. You need to know animals' habits and habitat, have concentration and control, and develop your senses. Your reward for practicing and improving these skills should be more and better opportunities to observe wildlife closely.

Physically demonstrate the following positions to your members. Then have them all try the same positions, as a group.

- Crouched position. What are the advantages? Practice it for a period of time.
- Freeze. There are certain situations when freezing is extremely important. When should you freeze? Practice freezing. How long can you sit absolutely still? Practice freezing in different positions.
- Quiet movement. Practice foot placement while maneuvering through a course with eggshells, peanut shells, styrofoam peanuts, etc. on the floor.
- Slow movement. How do animals move through the woods? Do they move prancing erratically or with deliberate movement? Try moving like that.
- Concentration. Slow body and head movement must be maintained even with unexpected movements and flashes around you. Practice with

distractions such as sharp sudden noise (slapping of two boards), camera flash, and movement.

- Self control. How do you control sneezes and coughs? Apply your finger on top of your nose to stop a sneeze or use your arm and body to muffle a cough.

In an outdoor setting near an appropriate habitat for the game you are tracking, practice the following skills:

- Identify animals. Practice identifying animals after seeing only parts of them from a distance.
- Identify tracks. What was the animal and what was it doing?



- Identify droppings. Identify the different droppings that you find outdoors. Note their location in the habitat.
- Identify browse. Identify different types of browse for these animals: deer, rabbit, porcupine, etc.

In an outdoor setting, let each member make an environmental assessment of the

area to look for factors that will influence the success of the stalking or still hunting. Factors to assess include:

- Cover: How do you use it? What is good cover (trees, rocks, small hills, beaver dams, cattails, etc.)?
- Rest points: What should you look for (comfort, break silhouette, quiet)? When should you use them (need a rest etc.)?
- Wind direction: With a fan blowing, briefly open a bottle of scent (skunk, fox urine, or perfume) downwind and then upwind. How does wind help you? How does it help the wildlife?
- Sun location: In what ways will the location and intensity of sunlight affect you? How can it help or hinder you?

In an indoor or outdoor setting, practice skills necessary for trained hearing. Learn to distinguish between different types of sounds. Ask a 4-H'er (the designated stalker) to close his or her eyes. Ask the group to keep quiet. Generate different noises (including paper rustling, branches breaking, and people whispering) near the stalker and ask him or her to identify the sounds. Note the difference between wrinkling paper and placing your hand or foot on wrinkled paper. Ask your members which type of animals make which type of sounds.

Questions To Ask

1. Why is slow movement so important?
Answer: Many animals are extremely sensitive to movement and recognize it better than still shapes. Moving slowly makes it less likely that you will be detected.

2. How can a person improve his or her ability to see animals in the wild?

Answer: Zoned viewing helps to organize what you see around you. View only one portion of the scene at one time. Don't move your head. Study only what you can see by moving your eyes. After studying one area, move your head slowly and view another. Remember, you will often see only a part of the animal at first, the nose, ears, tail, etc.

3. Why does complete concentration on the wildlife help you?

Answer: It sensitizes you to your own motion and noises and the natural sounds and movements around you.

4. How do you know where to look for wildlife?

Answer: Study the animal's habitats in a book, or ask people where it might be seen, and the part of the day it is likely to be active. Also learn what type of tracks and signs are associated with the animal you are looking for. Then go to an area you think might be good habitat and survey it for ideal spots, dens, nest, beds, tracks, and other signs of the animal.

Supporting Activities

Still hunting and stalking lends itself well to developing wildlife photography skills. Also, you can "hunt" wildlife with a camera in any season! Have the members practice taking pictures of wildlife using their still hunting and stalking skills, and ask them to arrange a wildlife photography exhibit for another group or local school.

24. Hunting From a Stand

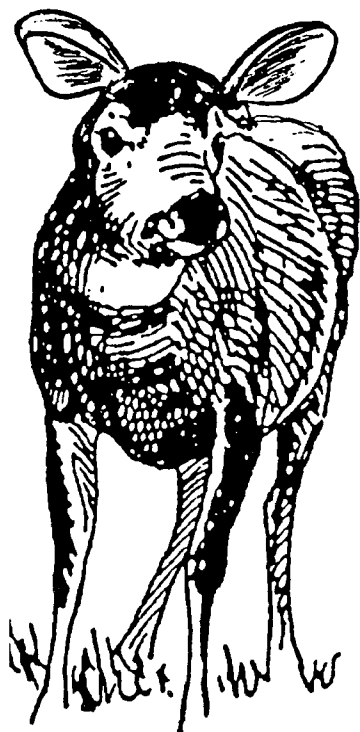

What 4-H'ers Will Do

4-H'ers will be able to:

1. Understand the methods and advantages of hunting from an elevated stand.
2. Know the laws governing the use of tree stands.
3. Understand where to locate stands for optimum results.
4. Build a stand.
5. Safely get into and descend from a stand.

Importance of the Topic

Stand hunting lets the hunter observe and detect an animal's movement before it is aware of the hunter's presence. Before using a stand, the hunter needs to learn certain skills, especially relating to safety.

Prepare for the Meeting

Read the instructional material and become familiar with the topic. Be prepared to answer questions. Plan a meeting(s) with junior leaders so they know their responsibilities. If possible, obtain a manufactured portable deer stand for the members to assemble and discuss. If possible, arrange a field trip into the woods to observe and choose proper terrain for the placement of the stand. Once the stand is erected, use it to practice safely ascending and descending and to observe.

Involving the Members

Have members work in teams of two to four to research the behavior and habitat requirements of large game (mule deer, white-tail deer, moose, elk, black bear). Teams should give a short report to the club. Junior leaders can stimulate discussion on how to set up the stand to hunt each species. Discuss points including:

1. Tree stand vs. ground stand (blind).
2. Locations: Look for a place that provides good cover and adequate food sources

for the animals. Game trails or “runs” are used year after year, generation after generation, but animals will change their habits with the seasons, as the food sources changes.

3. Construction: In Minnesota, the maximum legal height for tree stands is 16 feet.
4. Shooting and aiming from a stand.
5. Safety procedures: When moving up into or down from a stand, make sure the firearm or bow is unloaded or the firing mechanism is removed.

Questions To Ask

1. What time of day is best for hunting from a stand?
Answer: Early in the morning and just before dusk, when the deer are moving to and from feeding areas. Be

prepared at all times, since deer might be moving in response to other hunters.

2. Do deer use the same trails year after year?
Answer: Yes, but they will change their use pattern with the seasons as the food source changes.
3. Do you need permission from the landowner to erect a stand on private property?
Answer: Definitely yes.

Supporting Activities

If possible, invite an experienced stand hunter to talk to the members and to answer questions. As a group project, make a stand and erect it in a wooded area (after obtaining owner permission).

25. Hunting By Driving Game

Importance of the Topic

By teaching 4-H'ers how to hunt by driving game, you can ensure that they drive game safely. This unit also will enhance their decision-making skills and teach them to work cooperatively as a group. In driving game, the member uses the skills of identifying wildlife habitat, so he or she can move through habitat towards another hunter, ideally moving game with this pass.

Prepare for the Meeting

Pre-event planning is necessary to familiarize junior leaders or helpers with procedures or activities. Review the following project meeting guides:

- Using a Map and Compass
- Dressing for Hunter Safety



- Winter Habitat of White-tail Deer
- Stalking and Still Hunting
- Hunting from a Stand

What 4-H'ers Will Do

4-H'ers will be able to:

1. Learn additional safety skills for hunting.
2. Understand the importance of planning ahead while hunting.
3. Enhance group and cooperative skills.

Obtain a slide projector and screen. Borrow an aerial slide from your local Agricultural Stabilization and Conservation Service office. The slide should show broken terrain and a farmstead with a township or county road. If possible, it should also show a small lake or stream.

Involving the Members

Safety demonstration. This demonstration may be done indoors or out.

It will emphasize the necessary safety precautions for hunting by driving game. In front of the room, line up three 4-H'ers an equal distance apart, as "standers." In the rear of the room, line up all but two of the remaining 4-H'ers to be the "drivers." The remaining two will be the "deer."

Place about six chairs randomly between standers and drivers. Have the two deer move about from side to side in the room with drivers and standing members pretending to fire at will.

After several shots have been called out (bang, bang, bang, etc.) point out the number of fatalities they have created. Emphasize that no one should have shot until the deer were beyond the standing members or to the side of the outside drivers.

Discuss the Ten Commandments of Shooting Safety. Emphasize the importance of knowing where all other hunters are at all times. Discuss having a drive leader command the drive to promote safety and improve the success of the hunt.

Emphasize these rules of the drive:

1. Start the drive at the correct time.
2. Keep an even line of drivers.
3. Set a pace so even the slower people, or people with dense or extremely difficult terrain, can complete the drive comfortably.
4. Maintain the proper direction so drive ends up where intended.
5. At the end of the drive, account for all participants.

Show the aerial slide you chose earlier and plan the hunt:

1. Discuss the location of the four basic needs of wildlife (food, water, shelter, and space).

2. Discuss the location of the safe shooting corridors on your slide. Pay particular attention to the farmsteads, roads, lakes, livestock, and farmers working in fields or woods.
3. Review the deer's senses of smell and sound. Discuss how sound travels in cold weather and how wind carries the odor of hunters and standing members. This will help the 4-H'ers decide how to locate the drivers and standing members.
4. Emphasize the versatility of drive-type hunting. This system can work with 1 or 2 people driving and 10 or 12 standing, or just the opposite. A drive can be very successful with one person standing and one person driving. You must know your game and your countryside to make this type of hunting safe and enjoyable.
5. Stress projectile speed and potential travel distance and the effect of hitting frozen ground or water. Also remember to discuss ricochet from trees and rocks.
6. Emphasize the importance of dressing in blaze orange and following the other suggestions in the unit "Dressing for Hunter Safety."



7. Explain the effects on a hunt of extenuating circumstances such as sudden change of temperature, change of wind direction, sudden rain or snow. Review first aid for heat exhaustion, frostbite, heart attack, stroke, hypothermia, wounds, and fractures.

Questions To Ask

1. Can just two people hunt by driving game safely and successfully?

Answer: Yes, one can be the driver while the other can take the shot.

2. Is knowing game habitat important to driving game successfully?

Answer: Yes, otherwise you will

spend time trying to drive game in an area where it is not likely to be found.

3. What are some safety considerations to keep in mind when hunting by driving game?

Answer: Remember to wear blaze orange; start the drive on time; keep an even line of drivers; set an appropriate pace; maintain the correct, predetermined direction; and account for all the hunters at the end of the drive.

Supporting Activities

The group may go on a field trip into a wildlife area or a wooded area of a nearby farm. They could walk through the steps of a drive without guns.

26. Assessing Age, Size, and Trophy Status of White-Tail Deer

Importance of the Topic

Whether you are looking at a buck or doe, you need to know how to determine its age or size in relationship to other deer in the area. By doing this, we can better understand the deer's metabolism, environment, and daily habits.

What 4-H'ers Will Do

4-H'ers will be able to:

1. Unofficially score the antlers for Boone and Crockett Club or Pope and Young Club.
2. Determine the deer's approximate age.
3. Observe the habits of white-tail deer—food, water, shelter, and territory.

for big-game trophies. Contact the Boone and Crockett or Pope and Young Clubs to find official measurers in your area. The Minnesota Wildlife Heritage Foundation staff also has a list of people who can teach and measure big-game trophies.

For information about scoring white-tail deer and other big-game animals, lists of certified measurers, or molar charts, write to the following clubs:

Boone and Crockett Club—Firearms
241 South Fraley Blvd.
Dumfries, Virginia 22026

Pope and Young Club—Archery
1804 Borah
Moscow, Idaho 83843

Minnesota Wildlife Heritage Foundation
5701 Normandale Road, Suite 325
Edina, Minnesota 55424

Deer and Deer Hunting
PO Box 1779
Appleton, Wisconsin 54913

Bring to the meeting:

- Tape measure with 1/16" increments
- Alligator clips of a 30" piece of small wire cable
- Colored scotch tape
- Set of deer antlers
- Official score sheets for white-tail deer
- Books (i.e., *How to Measure and Score Big-Game Trophies*; *The White-tail Hunter's Almanac*.)

Prepare for the Meeting

Pre-meeting planning and preparation should involve as many junior leaders as possible. Plan a field trip to a deer yarding area between February and April to search for and collect antler sheds and to observe droppings, tracks, and other signs of white-tail deer. Try to find a certified measurer

- Worksheets for measuring, available from Boone and Crockett or Pope and Young Club (see above)
- Growth chart and molars of white-tail deer, available from Deer and Deer Hunting or from the Minnesota Department of Natural Resources.

Involving the Members

Measuring a Buck:

To measure and score deer antlers, add various measurements in inches and eighths of inches. The measurements include inside spread of main beam, length of main beams, length of tines, and the circumference of the main beams at specific points. Subtract differences in lengths that cause the rack to be asymmetrical. The worksheet provided by Boone and Crockett or Pope and Young is a very systematic and fair way to measure all white-tails throughout the world.

There are two classes of white-tail deer measurement: typical and non-typical. Some of the massive, multi-pointed, non-typical antlers are huge and even freakish.

Arrange tables and provide one antler shed or head for every five 4-H members. Provide the necessary measuring equipment and forms for every set of

antlers. Two members will do the measuring, two will record the data, and one may either observe or guide the group through the instructions on the score sheets.

Determining Sex/Age of White-tail Deer:

- In the fall, have the members cut a back molar tooth from a white-tail deer. Compare growth and wear to charts provided by the DNR or *Deer and Deer Hunting Magazine*. Also observe the total mouth structure and the presence of teeth to determine the deer's age.
- Dropping Size--Droppings 1/2 inch long are likely those of adult does or yearling bucks. Droppings 3/4 to 1 inch in length are those of 3-1/2 to 6-1/2 year old bucks.
- Bed size--The beds of adult does and yearling bucks are 40 inches in length. Fawns' beds range from 30 to 36 inches. Beds of 2-1/2 year old bucks are 45 inches long and 3-1/2 to 6-1/2 year old bucks have beds between 50 and 56 inches in length.
- Track Size--Tracks 5 inches or longer from tip to dew-claw are those of bucks only. Trophy-class bucks have tracks from 6 to 6-1/2 inches long or 4 inches for hoof only. A very large buck may



have a cloven hoof (1/2 of track) measuring 1 inch or more at its widest point.

- Rub Size--Yearling rubs are usually found on saplings 1 inch or less in diameter. The rubs of 2-1/2 year old bucks are usually found on trees 1-1/2 to 2-1/2 inches in diameter. Bucks 3-1/2 to 6-1/2 years old make rubs on trees 3 to 6 inches or more in diameter. Dominant bucks commonly make 30 or more single antler rubs along rut route trails throughout their breeding ranges.
- Ground Scrapes—There are six characteristics of a dominant buck's ground scrapes. They are:
 - renewed every 24 to 48 hours
 - two or more feet in diameter
 - turf and soil scattered widely
 - located at a traditional site
 - located on or adjacent to a major deer trail
 - mangled overhanging or adjacent branches

Questions to Ask

1. Do white-tail deer shed their antlers every year? When?
Answer: Most deer shed their antlers yearly between January and April.

2. What is "velvet"?
Answer: New antler growth in the spring of the year (May to June).
3. Does the number of points or tines correspond to the age of the animal?
Answer: No. Antler growth and size is related to the diet and metabolic condition of the animal.
4. What happens to deer sheds in the woods?
Answer: Rodents, porcupines, skunks, woodchucks, etc. consume them as a source of calcium.
5. Are trophy bucks usually more difficult to observe?
Answer: Yes. Most are older and have experienced many environmental situations, including escape from predators.

Supporting Activities

Visit a taxidermy shop to observe the various shapes and sizes of deer and other big-game antlers. Invite a wildlife specialist from the Minnesota Department of Natural Resources to speak at your group meeting, and ask him or her to bring samples of white-tail deer skulls (with molars intact).

27. Designing, Making, and Exhibiting a 4-H Shooting Sports/Wildlife Project

Importance of the Topic

All 4-H exhibitors need to learn how to properly design and construct exhibits. The competition in county and state fairs helps 4-H members develop life skills, including their abilities to solve problems and communicate with others.

Prepare for the Meeting

Prepare a poster or write on a chalkboard the following general *Rules for Exhibits*:

1. The exhibit may not exceed 12" deep x 18" wide x 22" high, except that a gun, bow and arrow, or taxidermy item included in a display will not be included in the calculations of dimensions.
2. No explosive materials or live ammunition is allowed in an exhibit.
3. Arrows must be secured so that their points or edges will not be a hazard.
4. Only sporting firearms and bows will be exhibited, displayed, or demonstrated.

Bring to the meeting, if possible, a sample of a previous poster display and a three sided hardboard display.

Bring materials needed to construct three-sided hardboard displays, including plywood or hardboard (see dimensions under "Rules for Exhibits"--note that the 18" wide rule applies to the total open dimension, not individual panels), hinges, and nails/hammers or screwdrivers/

screws. Ask each member to bring material for a display to the meeting (see appendix for premium listing).

You or the members can bring additional display-making materials, such as paint, construction paper, super glue, adhesive bond, grasses, sedges, etc.

Involving the Members

Make sure that all the 4-H'ers understand the rules for making an exhibit, sizes, and restrictions.

Using the sample of the previous poster display board and the three-sided hardboard display, point out advantages and disadvantages of each (see "Questions to Ask").

Help each member construct a three-sided hardboard display. Use a material such as plywood, hardboard, or

What 4-H'ers Will Do

4-H'ers will be able to:

1. Develop a design idea.
2. Construct a sturdy exhibit.
3. Plan an exhibit that will help to educate the public about environmental themes.

particleboard. Make sure that the open displayed dimensions do not exceed 12" deep x 18" wide x 22" high. Use hinges to attach the sections to each other. When you and the member are finished, the display should stand upright, with all three panels facing the viewer.

Using the appendix for ideas, brainstorm some additional topics or display concepts with the 4-H'ers. They can use the material that they have brought to the meeting to complete their exhibits, or start to plan a more elaborate exhibit at the fair.

Not all exhibits will be displayed on a three-sided display board. Deer antlers, plaster casts, taxidermy, and other projects will require different layout formats. Work with each 4-H'er individually to explore their ideas.

Finally, remind all 4-H'ers that much of their county and state competition is based on the knowledge they have of their subjects. Encourage them to study their subject thoroughly. Suggest that they think of questions to ask the judge, since conference judging provides an excellent opportunity for learning from the "experts" of a field!

Questions to Ask

1. What are the advantages of a three-sided hardboard display as compared to poster board?

Answer: The three-sided hardboard display is much more durable. This is especially important because many people handle the display--county agents, parents, participants, judges, and exhibit assistants, as well as hundreds, even thousands, of spectators.

The educational impact of a three-sided

hardboard display is also much greater, since you are giving your display a "three-dimensional" effect. More people will be attracted to an interesting display, and will be able to use that display as a learning tool.

2. Are there disadvantages to a three-sided display?

Answer: It is usually slightly more expensive to make than a poster board display. Also, if you have never made one before, you might need some help from a leader or parent.

3. I would like to display different types of bullets. I thought that I would glue some live ammunition onto a display and submit it. Is this allowed?

Answer: No. Live ammunition and explosive materials are not allowed at fairs.

4. I have some plastic toys that I could glue onto my display to simulate a range display. Should I do this?

Answer: Although this would make for an interesting display, toys and other such materials are often taken from exhibits by spectators. Keep in mind as you construct your display that many hundreds or thousands of people will pass by your exhibit.

5. Where can I get some ideas for a fair project?

Answer: See the appendix at the end of this book.

Supporting Activities

Let each 4-H'er give a presentation when his/her project is completed. Let the other members give pointers and constructive criticisms to the presenter.

Additional Readings and References

Books/Magazines:

- Archery* (sixth edition), McKinney/McKinney. William C. Brown Publishers.
- Archery: Steps to Success*, Haywood, K. and Lewis, C. U.S. Archer.
- The Art of Hunting*, Cy DeCosse Incorporated.
- Birds of North America*, Robbins, Burnn, Zim & Singer.
- The Black Powder Loading Manual*, DBI Books Inc.
- Cache Lake Country*, Rowlands.
- The Ducks, Geese and Swans of North America*, Fortright, Francis. Stackpole Publishing.
- The Ethical Hunter*, National Shooting Sports Foundation.
- 4-H Forest Resource Intermediate and Advanced Member's Guides, 4-H Youth Development.
- Hunter's Pocket Guide*, National Shooting Sports Foundation.
- Landscaping for Wildlife*, Henderson, C., 1981. Minnesota Department of Natural Resources, Nongame Wildlife Program.
- Minnesota's Endangered Flora and Fauna*, Coffin, Barbara and Pfannmuller, Lee.
- Minnesota Firearms Safety Training Manual*, Minnesota Department of Natural Resources, Firearm Safety Training.
- North American Hunter Education Program*, NRA Hunter Services Division.
- Of Men and Marshes*, Errington, Paul.
- The Old Man and His Boy*, Ruark, Robert.
- One Man's Forest*, Stephens.
- Outdoor Life* magazine.
- 1001 Questions Answered About Birds*, Cruickshank.
- Project Wild Activity Guide*, Project Wild. Regional Environmental Education Council.
- A Sand County Almanac*, Leopold, Aldo.
- Sensabout Bow Tuning*, Loiselle, Emery. Eryleen Publication.
- Shotgun Sports* magazine.
- Sports Afield* magazine.
- Ten Commandments of Shooting Safety*, Minnesota Department of Natural Resources.
- The Uncommon Ones: Minnesota's Endangered Plants and Animals*, Minnesota Department of Natural Resources.
- The White-tail Hunters Almanac*, Nordberg, Ken. Shingle Creek Outdoor Products.

Addresses:

4-H Youth Development
University of Minnesota
1420 Eckles Avenue
St. Paul, Minnesota 55108-1030

Minnesota Deer Hunters Association
406 Highway Street N.W.
Box 162
Dodge Center, Minnesota 55927

Minnesota Department of Natural
Resources
500 Lafayette Road
St. Paul, MN 55155

Minnesota Extension Service
Educational Development System
University of Minnesota
1420 Eckles Avenue
St. Paul, Minnesota 55108-1030

NRA Hunter Services Division
1600 Rhode Island Avenue, NW
Washington, DC 20036

National Shooting Sports Foundation
1075 Post Road
Riverside, CT. 06878

Project Wild/Project Aquatic
Minnesota Department of Natural
Resources
500 Lafayette Road
St. Paul, MN 55155

APPENDIX A: Range Commands and Etiquette for BB Gun, Air Pistol, Air Rifle, and Smallbore Rifle and Pistol

Shooters to the Line

(5 to 10 minutes)

This is the time shooters use to get their equipment to the shooting line.

Firearms are uncased at shooting line.

Firearms are pointed down range, muzzle down range.

Actions are open.

Firearms are not handled.

Preparation Time Has Started

(5 to 10 minutes)

Shooters may prepare the equipment for their particular shooting position.

They may handle firearm with no ammunition.

Fingers are outside the trigger guard.

Is the Line Ready?

Ready on the left?

If the answer is "no", give more time; if "yes", continue.

The line is ready.

Shooters Load Your Firearm

Single load only. DO NOT FIRE.

Commence to Fire

Fire designated rounds.

When finished shooting, lay firearm down, with action open and muzzle down range.

Cease

Muzzle is down range, action open. LAY FIREARMS DOWN. It may mean:

1. There is a problem on the line.
2. The discipline or round is over.
3. A new set of targets is to be used.
4. Examine your targets down range.
5. The range is unsafe.

Is the Line Clear?

If you hear a response of "no," see what the problem is.

Range is Closed

Shooters case the firearm, pick up their equipment, and remove from the firing line.

Encased firearms may NOT be handled.

APPENDIX B: Shooting Sports/Wildlife Premium List, Exhibit Class, Minnesota State Fair¹

Class 3701 Beginner

- Lot 01 Safety and safety techniques.
- Lot 02 Wildlife biology/wildlife management and their basic concepts.
- Lot 03 Game identification.
- Lot 04 Archery shooting skills.
- Lot 05 Shotgun shooting skills.
- Lot 06 Air pistol shooting skills.
- Lot 07 Rifle shooting skills.
- Lot 08 Muzzle loading shooting skills.
- Lot 09 Junior leadership skills.
- Lot 10 History and nomenclature of trapping, hunting, firearms, and nongame wildlife.
- Lot 11 Sportsmanship--ethical behavior and responsibility.
- Lot 12 Game cookery.
- Lot 13 Taxidermy.
- Lot 14 Project activities not applicable to Lots 01 to 13 that have direct application to the Shooting Sports/Wildlife Project.

Class 3702 Intermediate

(Same as class 3701)

Class 3703 Advanced

(Same as class 3701)

¹ Note: the premium list is subject to minor changes each year. Please consult the current year 4-H State Fair Program or premium list, available from 4-H Youth Development, 340 Coffey Hall, St. Paul, MN 55108.

UNIVERSITY OF MINNESOTA



3 1951 D02 936 179 T

Issued in furtherance of cooperative extension work in agriculture and home economics, acts of May 8 and June 30, 1914, in cooperation with the U.S. Department of Agriculture. Patrick J. Borich, Dean and Director of Minnesota Extension Service, University of Minnesota, St. Paul, Minnesota 55108. The University of Minnesota, including the Minnesota Extension Service, is committed to the policy that all persons shall have equal access to its programs, facilities, and employment without regard to race, religion, color, sex, national origin, handicap, age, veteran status, or sexual orientation.

Copyright © 1990 by Minnesota Extension Service, University of Minnesota. All rights reserved. No part of these materials may be reproduced, transmitted, transcribed, stored in a retrieval system, or translated into any language or computer language, in any form or by any means, electronic, mechanical, magnetic, optical, chemical, manual, or otherwise, without the prior written permission of Minnesota Extension Service, Distribution Center, Room 3 Coffey Hall, 1420 Eckles Avenue, University of Minnesota, St. Paul, MN. 55108

The information given in this publication is for educational purposes only. Reference to commercial products or trade names is made with the understanding that no discrimination is intended and no endorsement by the Minnesota Extension Service is implied.



The 100% recycled paper used for this publication contains 10% post-consumer waste.