

11N 2000
6B-384
c.2

c.2

THE CARE AND SIMPLE REPAIR OF HOUSEHOLD EQUIPMENT

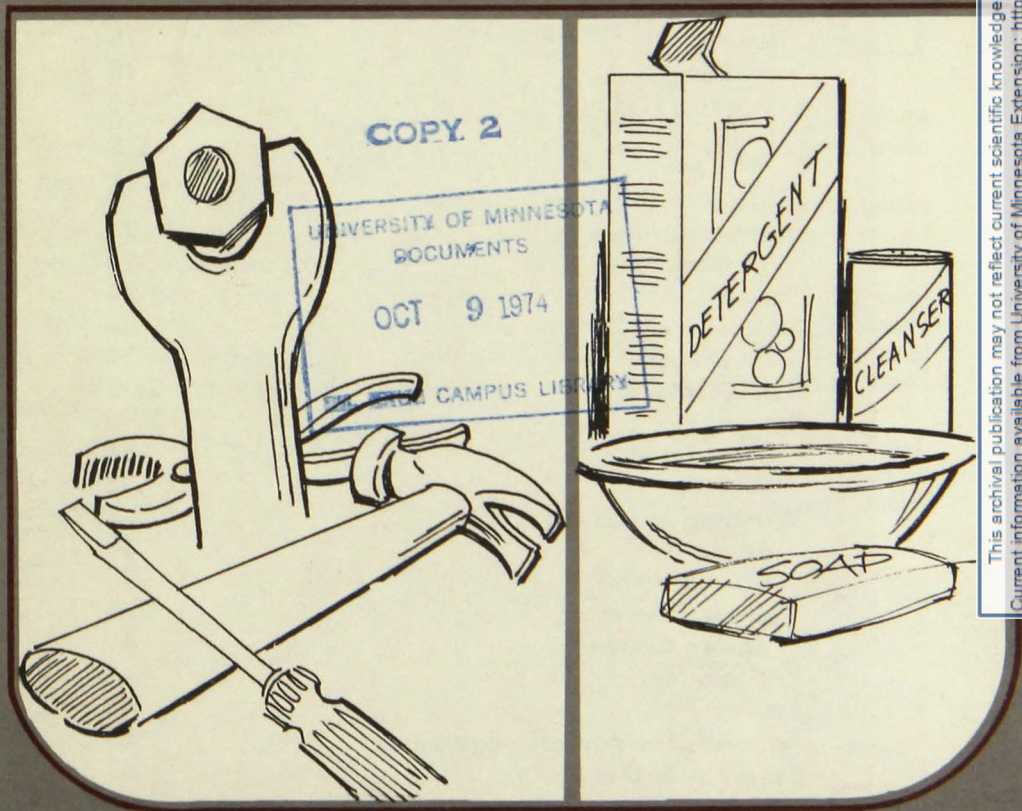

This archival publication may not reflect current scientific knowledge or recommendations.
Current information available from University of Minnesota Extension: <http://www.extension.umn.edu>.

TABLE OF CONTENTS

Fuses – Cords – Plugs	4-10
Fuses or Circuit Breakers	4
Testing Cords and Plugs	6
Plugs and Cords	7
Attaching Plugs to Cord	8
Attaching Appliance Plugs	9
Attaching Socket to Cord	10
Splicing Cords	10
Adjusting Plug Prongs	10
Care of the Cord	10
Small Appliances	11-25
Small Heating Appliances	11
Hand Iron – Dry Type	12
Hand Iron – Steam Type	13
Heating Pad or Electric Blanket	14
Hot Plates	15
Percolator	15
Roaster or Fry Pan	16
Toaster	17
Waffle Iron	18
Small Motor-Operated Appliances	19
Vacuum Cleaners	21
Household Fans	23
Mixer	24
Blender	24
Can Opener	25
Refrigerators	26-29
Ranges	30-35
Electric Range	30
Gas Range	33
Washing Machines	36-39
Wringer Type	36
Automatic Washer	38
Clothes Dryers	40-41
Pressure Cooker	42
Kitchen Utensils	43
Knives	44
Grounds for Portable Equipment	45
Safety with Electricity	47

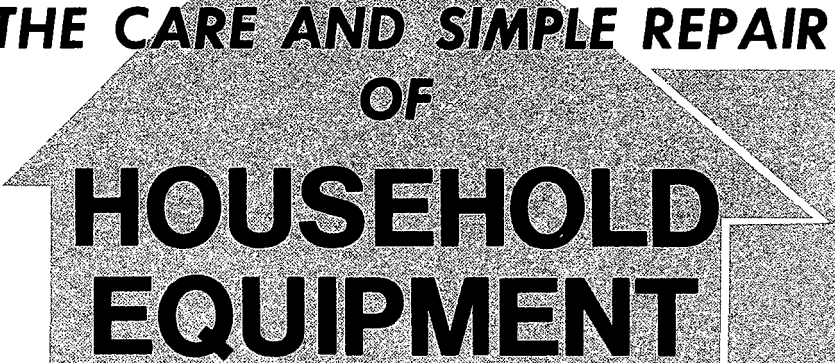

THE CARE AND SIMPLE REPAIR OF HOUSEHOLD EQUIPMENT

Revisions made by: Miss LaVerne Farmer, Associate Professor,
Home Management
Kenneth E. DeBusk, Associate Professor,
Agricultural Engineering

Every family should plan to make household equipment last as long as possible. Daily care and needed repair of equipment will determine the length of its usefulness.

A set of instructions for use and care of equipment usually comes with new appliances. Keep these instructions convenient for use and always follow them carefully.

This publication has been prepared to help families properly care for equipment, as well as to locate minor troubles and make simple repairs. Some mechanical difficulties will develop which are not covered in this publication. For these repairs, obtain the services of a trained repairman.

Repair of many small appliances is tedious and time consuming. Some repair parts are expensive. Often the better alternative is to purchase a new appliance. A qualified and honest repairman can assist you in making this decision.

HOME TOOL KIT

The following tools will be helpful in making simple repairs at home.

Screw Drivers	Nails	Hammer	Flat File
Wrenches	Tacks	Ruler	Whet Stone
Knife	Screws	Brush	Oil Can
Putty Knife	Pliers	Ice Pick	Electrical Tape

HOW TO USE THE INSTRUCTIONS IN THIS BOOKLET.

1. Refer to the specific trouble. The trouble may be due to one cause or to a combination of several causes.
2. Begin with the first cause listed. Check over the part of the appliance directly concerned. Either repair or replacement may be necessary. Try the appliance after making repair or replacement.
3. Take each of the other causes in order listed. Treat them as described until the appliance operates satisfactorily.

Fuses-Cords-Plugs

FUSES OR CIRCUIT BREAKERS

The wiring circuits in homes and farm buildings are protected by either fuses or circuit breakers. When fuses blow or circuit breakers trip—the cause is **not** in the fuse or circuit breaker, but some place in the cord, plug, equipment, or wiring system; or, the circuit is overloaded. **Locate the trouble and correct it before replacing fuse or resetting circuit breaker.**

1. **PLUG FUSES** are round. They screw into the fuse socket. Fig. 2.
2. **NON-TAMPERABLE FUSES** are round. The adapter screws into the fuse socket. Once the adapter is in, it locks and cannot take a fuse larger than the rating of that particular adapter.

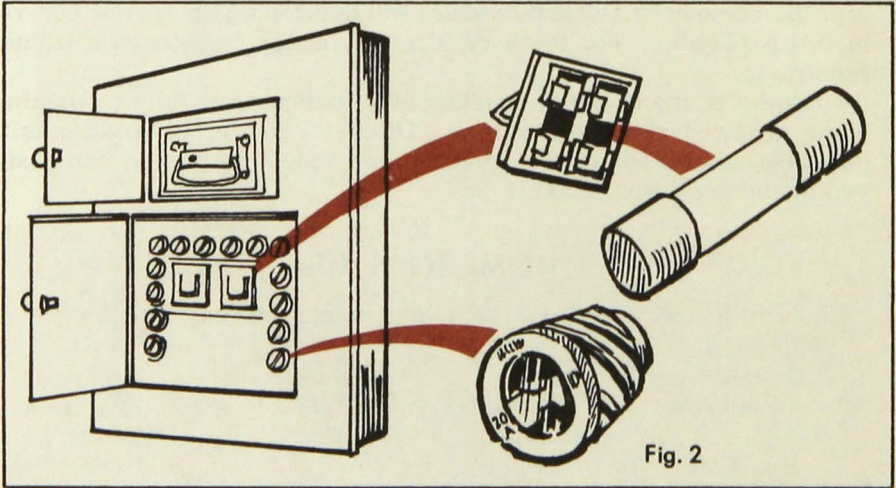

Fig. 2

Fuses-Cords-Plugs

3. TIME DELAY FUSES are made to carry 100 percent overload for about 30 seconds. They will blow on overloads lasting a few minutes. This type fuse is desirable when there are several motor-driven appliances in the home.
4. CARTRIDGE FUSES are generally used for the main circuit, range, and water heater. Fig. 2 Top.

Replacing a Fuse

- a. Stand on dry board or mat. Fig. 3.
- b. Open main switch. Fig. 2 or 3.
- c. Correct trouble causing fuse to blow.
- d. Remove blown fuse. Fig. 2.
- e. Replace with correct size.
- f. Close main switch.

5. CIRCUIT BREAKER: The circuit breaker takes the place of fuses and a switch.

Resetting Circuit Breaker Fig. 4.

- a. Move handle to "OFF" position.
- b. Push handle past "OFF" position.
- c. Return handle to "ON" position.

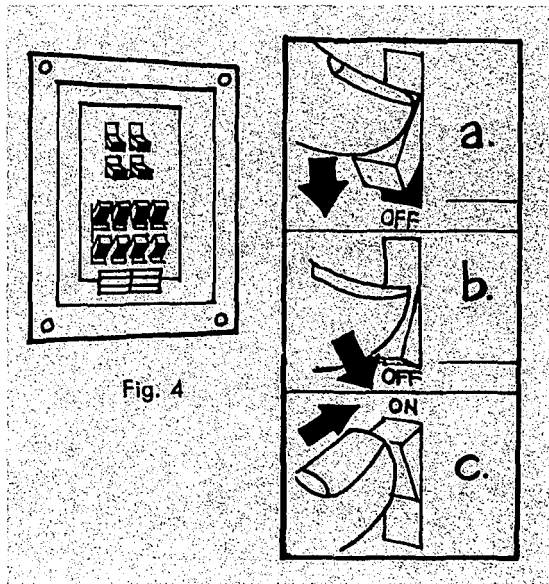
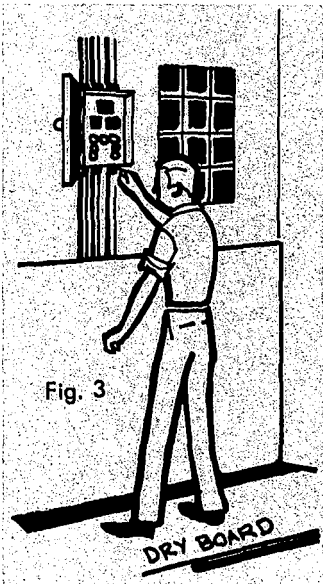

Fuses-Cords-Plugs

TESTING FOR TROUBLE IN THE ELECTRIC CIRCUIT

1. Disconnect all appliances.
2. Open main switch.
3. Remove blown fuse.
4. Insert a light bulb. Fig. 5.
5. Close the main switch.
If the bulb burns, a short exists in the wiring system. If the bulb does not burn, the trouble will be found in the plug, cord or equipment.

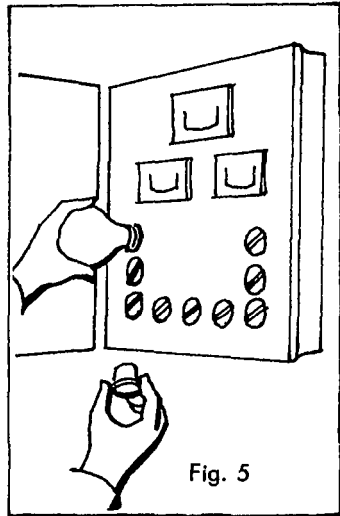

TESTING CORDS AND PLUGS

1. Plug cord into convenience outlet. Fig. 6.
2. Insert circuit tester into appliance plug. Fig. 6. If the tester lamp does not burn, the cord or plugs need to be repaired.

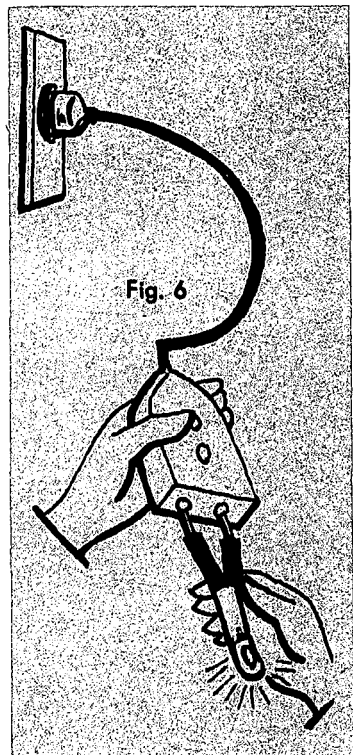
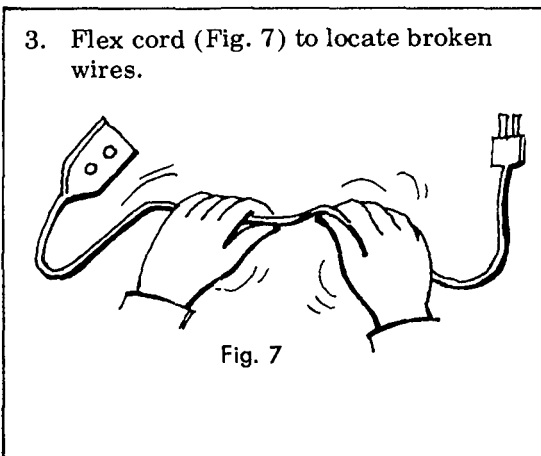

Fuses-Cords-Plugs

PLUGS AND CORDS

TYPES OF PLUGS

Plug for Convenience Outlet: May be bakelite (A and B), rubber (C), or hard rubber metal covered (D), or heavy duty grounding (E). Fig. 8.

Appliance Plug: Used on heat appliances, such as iron, roaster, and waffle iron. Fig. 9. These are commonly found in three sizes.

Detachable Control and Cord: Used on many grills, waffle irons, and other small appliances. Sometimes interchangeable between small appliances. Fig. 10.

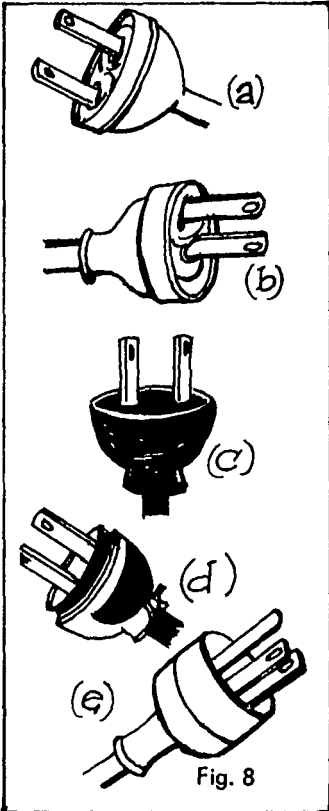

Fig. 8

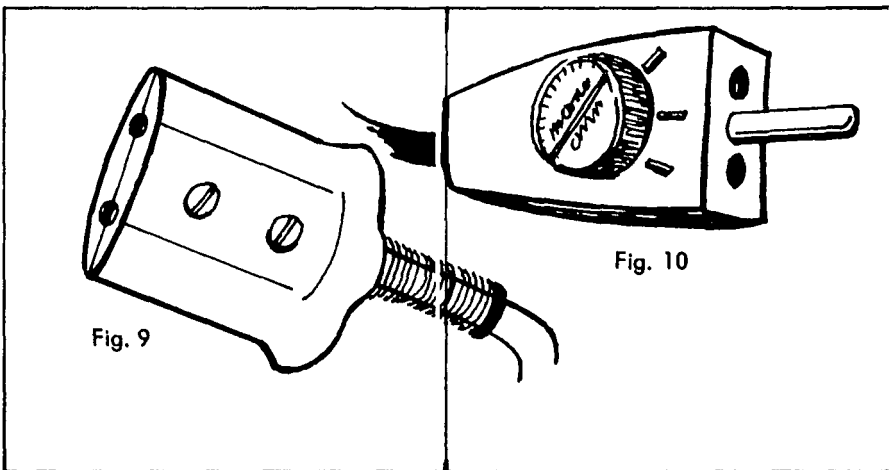

Fig. 9

Fig. 10

Fuses-Cords-Plugs

TYPES OF CORDS

Light Duty Rubber Covered Cord: Used on some equipment as braided cords. Fig. 11.

Heating Appliance Cords: Used for roasters, hotplates, irons and heat appliances. Fig. 12.

Heavy Duty Rubber Covered Cord: Used for vacuum cleaner and washing machines; resistant to moisture and mechanical injury. Fig. 13.

Braided Cords: Sometimes used for fans, lamps, and sewing machines.

Ground Appliance Cord: Used for portable tools and appliances. Fig. 14.

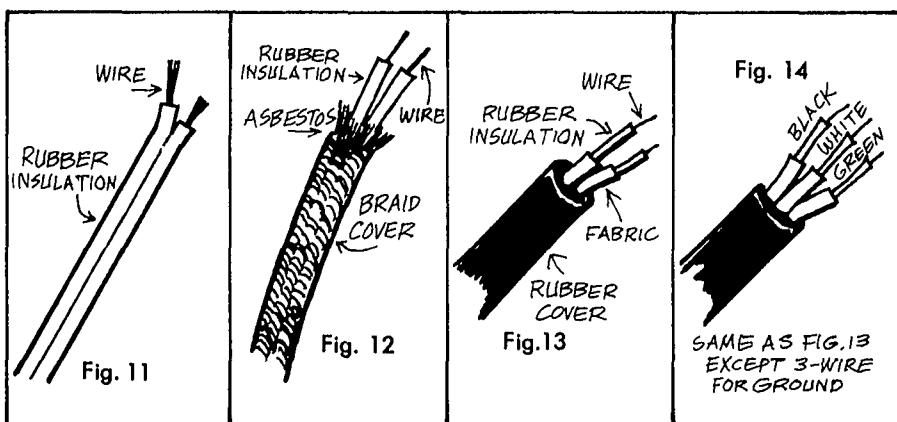

ATTACHING CONVENIENCE OUTLET PLUG TO CORD

1. Pass cord through cap. Fig. 15.
2. Follow steps indicated in Figure 15 and make the under-writers knot.
3. Remove $\frac{1}{2}$ -inch of rubber insulation. Fig. 15.
4. Twist strands of wire tightly.
5. Connect wire around screw in direction in which screw tightens and see that all wire strands stay under screw as it tightens.
6. A quick-attach type plug can be obtained for use on light duty cords.

Be sure that insulation comes to screw terminal but does not extend under it.

Fuses-Cords-Plugs

ATTACHING APPLIANCE PLUG TO CORD

1. Disconnect the cord from the convenience outlet before starting repair.
2. Disassemble plug on end of cord where it connects to appliance.

Notice carefully the placement of each part.

3. Remove $2\frac{1}{2}$ -inches of outer covering. Fig. 16a.
4. Run cord through spring protector. Fig. 16b.

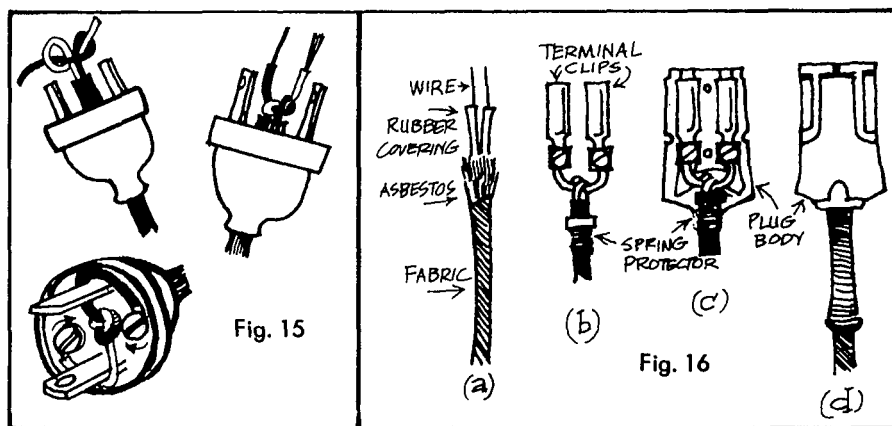

5. Fit wires into one-half of plug temporarily to determine how long the individual wires should be. Cut them to proper length.
6. Remove about $\frac{1}{2}$ -inch rubber insulation from end of each wire. Fig. 16a.
7. Tie underwriter knot as shown in Figs. 15 and 17.
8. Make terminal connections. Fig. 16b.
9. Place terminal clips and spring into one-half of plug. Fig. 16c.
10. Fit sides of plug together and replace screws or clamps.
11. Inspect convenience outlet plug at other end of cord, and test connections. Figures 15 and 6.

Fuses-Cords-Plugs

ATTACHING SOCKET TO CORD

Follow directions shown in Fig. 17 to attach socket. This type socket is for use on portable lamps.

SPLICING CORDS (Two Methods)

1. By cutting out the broken piece and inserting a cord connector. Fig. 18.
2. By cutting out the frayed or broken parts of the cord, splicing and soldering. Tape each wire properly. Fig. 19. Caution: Splicing of cords is not recommended and even carefully spliced cords should be replaced as soon as possible.

ADJUSTING PLUG PRONGS

Plug prongs sometimes do not fit the convenience outlet properly. The prongs may be spread to fit tightly into the receptacle. Fig. 20.

CARE OF THE CORD

1. Store in cool and dry place.
2. Do not bend sharply.
3. To disconnect, grasp plug instead of cord.
4. Always disconnect appliance cord from wall outlet rather than from appliance.
5. Keep oil and grease away from cords.
6. Do not place cord under rug or in door jambs.

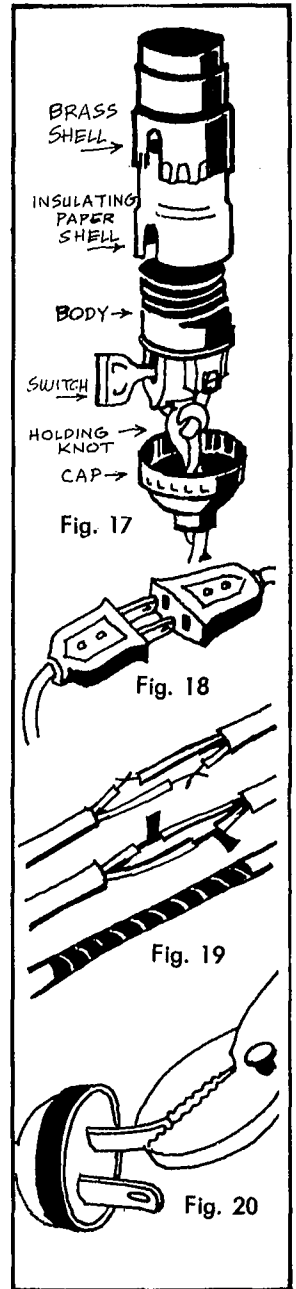

Small Appliances

Small electrical appliances are divided into two groups: (1) Small Heat Appliances and (2) Motor Driven Appliances.

SMALL HEATING APPLIANCES

Heating coils on small appliances are of two general types. Totally enclosed coils which cannot be repaired in the home, and open-type coils in which a temporary repair sometimes can be made.

REPAIRING OPEN COIL HEATING ELEMENTS

1. Re-attaching the broken coil to the terminal.
This repair can be made only when the break is close to the terminal. Fig. 21.
 - a. Clean the wire at least $\frac{1}{2}$ -inch from end.
 - b. Fasten around terminal in direction screw or nut tightens. Fig. 21.
2. If the break in the coil is away from the terminal it is advisable to return it to dealer for repair.

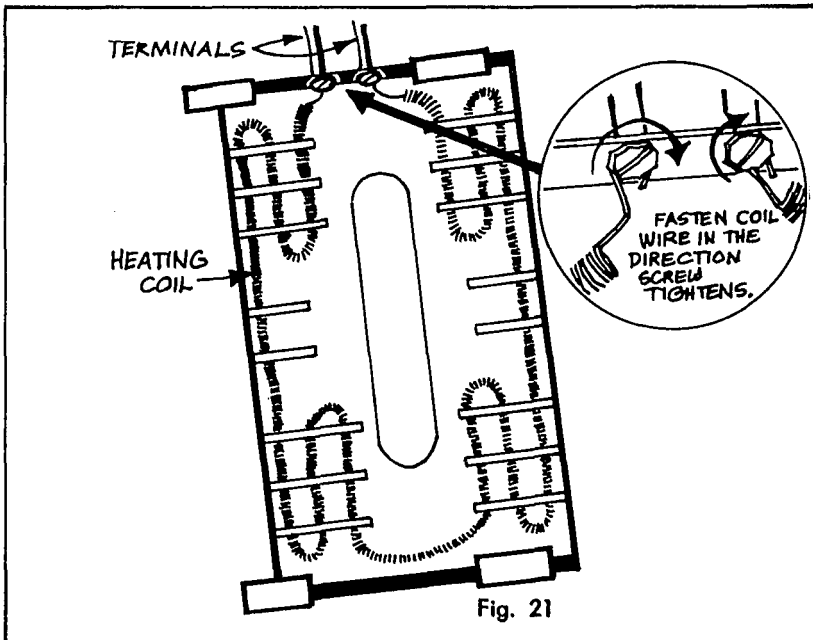

Small Appliances

HAND IRON - DRY TYPE

I. Iron Does Not Heat

1. Cause: Loose connection at wall outlet; fuse blown; cord or plug needs repairing.
Remedy: See page 4, Fuses - Cords - Plugs.
2. Cause: Thermostat not operating.
Remedy: Return to dealer, serviceman, or manufacturer for repair.
3. Cause: Heating element burned out.
Remedy: Return to dealer, serviceman, or manufacturer for repair.

II. Iron Slow to Heat

1. Cause: Connected to light socket or extension cord.
Remedy: Connect the iron directly to wall outlet.

III. Iron Overheats

1. Cause: Thermostat set too high.
Remedy: Set thermostat to lower heat.
2. Cause: Thermostat operating improperly.
Remedy: Return to dealer, serviceman or manufacturer for repair.

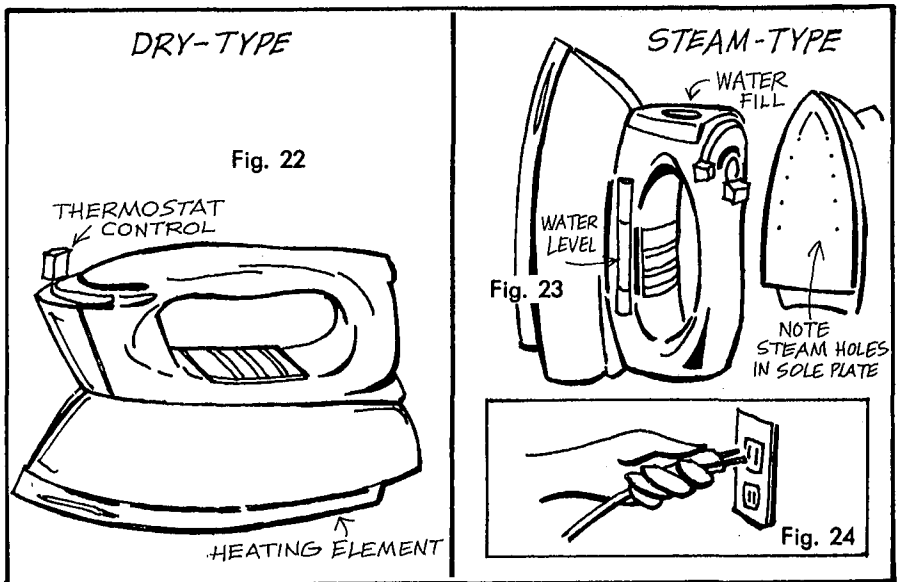

Small Appliances

HAND IRON - STEAM TYPE

The steam iron differs from the dry iron only in that there is a method of inserting water and obtaining steam. The troubles and remedies given for the dry iron will also apply to the steam iron. However, additional troubles are common in the steam iron.

- I. **Iron heats but no steam comes through the holes in the sole plate.**
 1. **Cause:** Passageways from water reservoir to holes in sole plate have become clogged with scale.
Remedy: The best remedy is prevention of scale formation by using soft, mineral-free water. Special commercial solvents will sometimes help in cleaning out these passageways after scale has formed.

- II. **Iron "spits" steam or water out of holes in the sole plate.**
 1. **Cause:** Passageways from water reservoir to sole plate have become clogged with scale.
Remedy: Same as for trouble I (above).

Care, Cleaning and Operation

1. The iron will sometimes stick to clothing. This is particularly true if too much starch has been used. A small amount of salt in the starch will help to keep the iron from sticking. The iron may stick to rayon or synthetic fabrics because the iron is too hot.
2. The sole of the hot iron may be cleaned by rubbing it in salt sprinkled on waxed paper, or on paraffin. Polish with a dry cloth.
3. Disconnect the cord of the iron by grasping the plug—never by pulling the cord.
4. Never put iron in water.
5. Most electric irons are designed to rest on their heels. If a flat stand is used the heat may rise and damage the handle.
6. Never wrap the iron cord around a hot iron. Heat is injurious to rubber and will shorten the life of the cord.
7. Keep the iron in a dry place when not in use.

Small Appliances

HEATING PAD OR ELECTRIC BLANKET

I. Heating Pad Or Blanket Does Not Heat

1. Cause: Fuse blown, cord or plug needs repair.
Remedy: See Page 4, Fuses - Cords - Plugs.
2. Cause: Broken switch or loose contacts in switch.
Remedy: If switch is broken, replace it. If contacts are sprung or worn they sometimes can be repaired by bending or springing them as shown in Fig. 25.

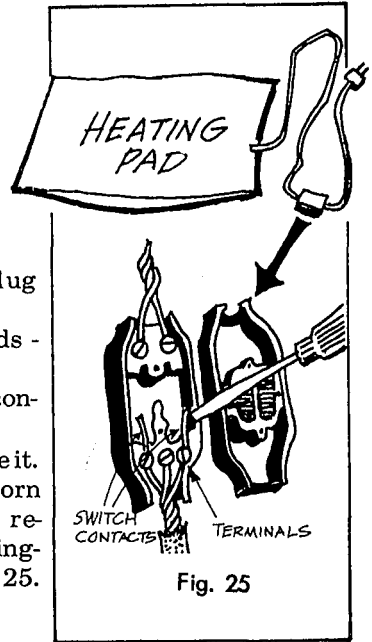

Care, Cleaning and Operation

1. Keep heating pad or blanket dry.
2. Do not bend or fold more than necessary. The pad or blanket has small, low-temperature heating wire placed in an asbestos blanket. Bending or folding pad will eventually break heating element.
3. Place the heating pad in a pillow case or keep in cover provided to protect the pad.
4. Never put pins through heating pad or blanket as pins may short circuit the heating coils or break them.
5. Never store pad in folded position.

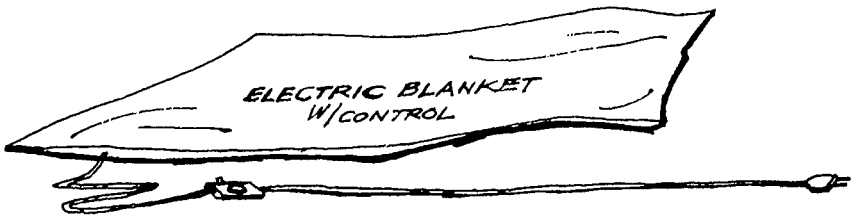

Small Appliances

HOTPLATES

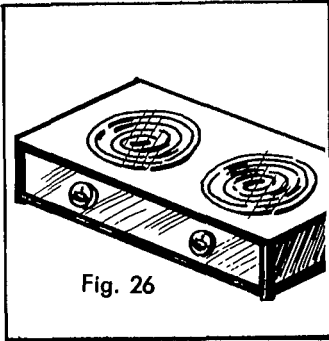

Fig. 26

Hotplate Will Not Heat

1. Cause: Fuse blown, cord or plug needs repair.
Remedy: See Page 4, Fuses - Cords - Plugs.
2. Cause: Broken or burned out heating element.
Remedy: See repair of heating elements, Page 11.

Care, Cleaning and Operation

1. Never put hotplate in water.
2. Clean metal part of hotplate with damp cloth. Whiting and soap may be used to remove stains and greases.
3. If excessive greases or syrups are spilled on heating unit: First, wipe off with a dry cloth; second, turn the switch to "high" position and burn the remaining greases and syrups off the unit.
4. Burned particles on the heating element may be removed by using a soft brush.

PERCOLATOR

I. Percolator Will Not Operate

1. Cause: Fuse blown, cord or plug needs repair.
Remedy: See Page 4, Fuses - Cords - Plugs.
2. Cause: Percolator fuse blown. Fig. 27.
Remedy: Examine bottom of percolator for fuse. It may be necessary on old models to remove bottom plate to replace fuse.
3. Cause: Percolator stem may be clogged.
Remedy: Clean the valve or stem by forcing water through it or use a small round brush. Fig. 28.

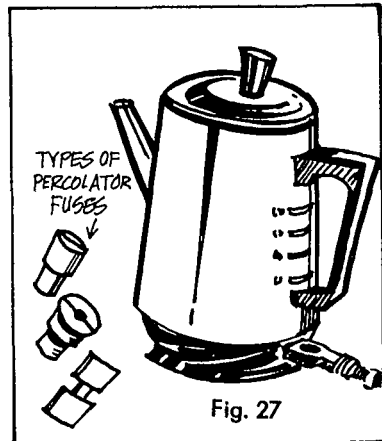
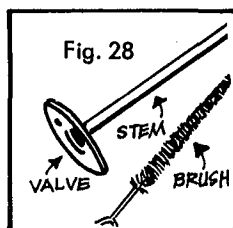

Fig. 27

Small Appliances

4. Cause: Valve not seated in heating well.
Remedy: Clean heating well and valve.
5. Cause: Percolator heating element burned out.
Remedy: Return to serviceman, dealer, or manufacturer for replacement.



Care, Cleaning and Operation

1. Bitterness in coffee may be caused by allowing coffee to stand in percolator, using stale coffee, or allowing coffee to percolate too long.
2. The percolator should be washed occasionally with water to which has been added one tablespoon of vinegar or soda to six cups of water. Percolate this mixture 10 minutes to remove any stale odors. Rinse with clean water.
3. The inside of the percolator should be washed with soap and water. The outside may be cleaned with silver polish or whiting and soap.
4. Coarse scouring powder should not be used.

ROASTER OR FRY PAN

I. Roaster or Fry Pan Is Not Heating

1. Cause: Thermostat set on "OFF" position.
Remedy: Set thermostat to desired temperature. Figs. 29 and 30.
2. Cause: Fuse blown, cord or plug needs repair.
Remedy: See Page 4, Fuses - Cords - Plugs.

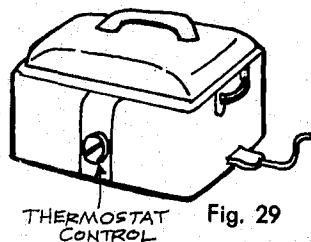

II. Roaster or Fry Pan Does Not Heat Properly

1. Cause: Thermostat set too low.
Remedy: Set thermostat at higher position.
2. Cause: Connected to drop cord or long extension cord.
Remedy: Connect to wall outlet.

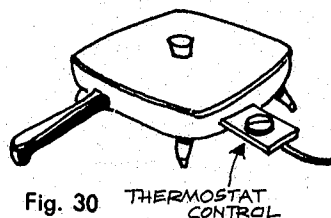

Small Appliances

3. Cause: Lid may be warped or sprung.
Remedy: Return to dealer, serviceman, or manufacturer for repair.

III. Roaster or Fry Pan Gets Too Hot

1. Cause: Thermostat set too high.
Remedy: Place thermostat at lower setting.
2. Cause: Thermostat operating improperly.
Remedy: Return to dealer, serviceman, or manufacturer for replacement.

Care, Cleaning and Operation

1. Clean the outside with damp cloth. Whiting and soap may be used to remove grease spots.
2. Do not place the unit which holds the thermostat in water for cleaning. Some thermostats are detachable, which allows immersion of appliance in water after thermostat is removed.
3. Do not connect to a drop cord or extension cord because the wires are too small for satisfactory heating. Connect appliance directly to a wall outlet.
4. Do not use appliance on a circuit on which another heating appliance is in use.
5. Store the appliance and fry pan in a dry place.

TOASTER

There are three general types of toasters: automatic, semi-automatic, and non-automatic.

The troubles and remedies given here may apply to all toasters but do not include mechanical troubles found in automatic or semi-automatic toasters.

I. Toaster Will Not Heat

1. Cause: Fuse blown, cord or plug needs repair.
Remedy: See Page 4, Fuses - Cords - Plugs.
2. Cause: Heating element broken or burned out.

Remedy: Return to serviceman, dealer, or manufacturer for repair.

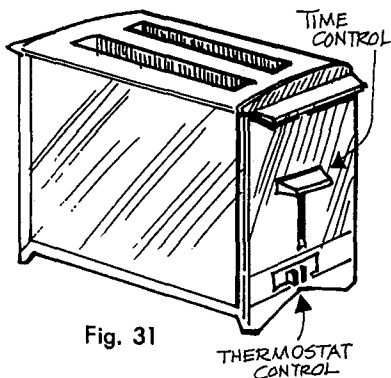

Fig. 31

Small Appliances

Care, Cleaning and Operation

1. Disconnect toaster plug from receptacle before cleaning.
2. Never put toaster in water to clean. Use a damp cloth—not wet—to wipe inside. Whiting and soap or any mild abrasive may be used to clean stains or grease spots from metal parts of toaster. A soft bristle brush should be used to clean bread crumbs from inside. It may be necessary to remove bottom plate. Fig. 31.
3. Do not wrap cord around toaster while the toaster is hot.

WAFFLE IRON

I. Waffle Iron Will Not Heat

1. Cause: Fuse blown, cord or plug needs repair.

Remedy: See Page 4, Fuses - Cords - Plugs.

2. Cause: Connecting cord between upper and lower element broken.

Remedy: Disassemble and repair in the same manner as any other cord. Fig. 32.

3. Cause: Heating coil burned out. Fig. 32.

Remedy: See repair of heating element, Page 11.

II. Waffle Iron Overheats (automatic type)

1. Cause: Thermostat damaged or stuck.

Remedy: Return to dealer, serviceman, or manufacturer for repair.

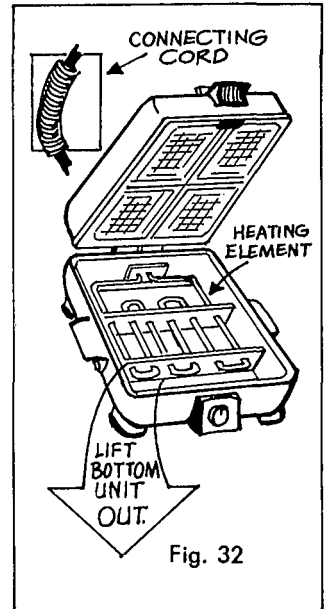

Care, Cleaning and Operation

1. Grids may be cleaned by placing a paper napkin soaked with ammonia between them and leaving it overnight. Clean with steel wool and whiting.
2. Waffles will sometimes stick on new grids or grids recently cleaned. To eliminate this trouble, grids may be greased with unsalted fat and iron pre-heated thoroughly.
3. Waffle iron should be left open until cool.

Small Appliances

SMALL MOTOR-OPERATED APPLIANCES

I. Motor Does Not Start

1. Cause: Blown fuse, cord or plug needs repair.
Remedy: See Page 4, Cords - Plugs - Fuses.
2. Cause: Motor damaged.
Remedy: Return to dealer, serviceman, or manufacturer for repair.

II. Motor Runs Hot

Motors in constant use may operate at a temperature hot enough to be uncomfortable to the touch, but not cause smoke.

1. Cause: Motor bearings need lubrication.
Remedy: Turn motor shaft by hand.
See that it turns freely and does not stick. Lubricate according to manufacturer's directions.

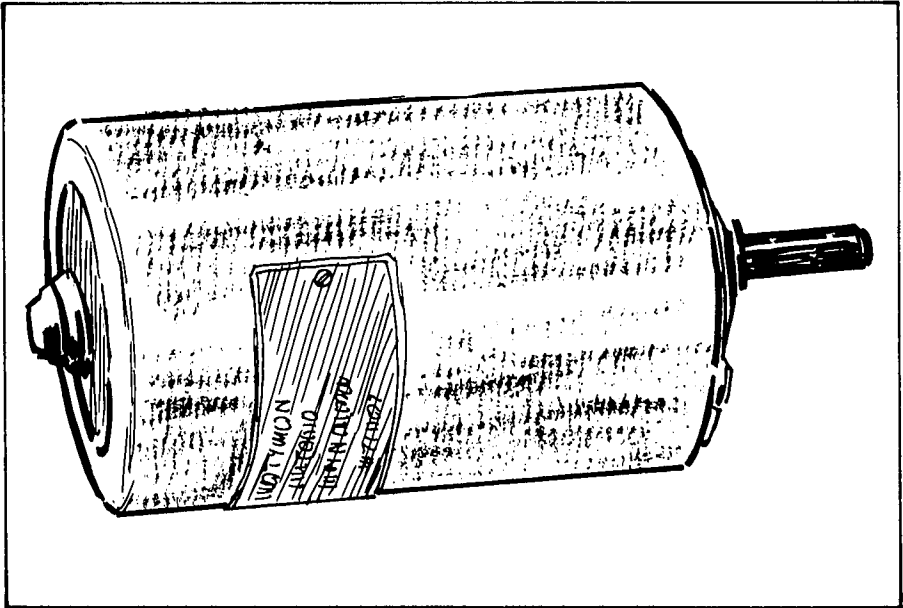

Small Appliances

2. Cause: Motor overloaded.
Remedy: If the motor on a vacuum cleaner runs hot, empty and clean the bag. If the motor on a mixer runs hot, the batter is too stiff. If the motor on other equipment runs hot, see if equipment needs lubricating or adjusting.
3. Cause: Low voltage.
Remedy: If long runs of small wire are being used, remove and plug directly into a house lighting circuit. If this fails to remedy the trouble, ask your power distributor to check your house voltage.
4. Cause: Dust or dirt in the motor windings, especially household fans.
Remedy: Blow and wipe the dust out of the motor; avoid over-oiling.
5. Cause: Motor windings damaged, or other internal trouble.
Remedy: Return to dealer, serviceman, or manufacturer for repair.

III. Motor Operates But Does Not Come Up To Full Speed

1. Cause: Overload.
Remedy: See Item 2, above.
2. Cause: Low voltage.
Remedy: See Item 3, above.
3. Cause: Motor in need of lubrication.
Remedy: Lubricate according to manufacturer's directions.
4. Cause: Motor damaged.
Remedy: Return to serviceman, dealer, or manufacturer for repair.

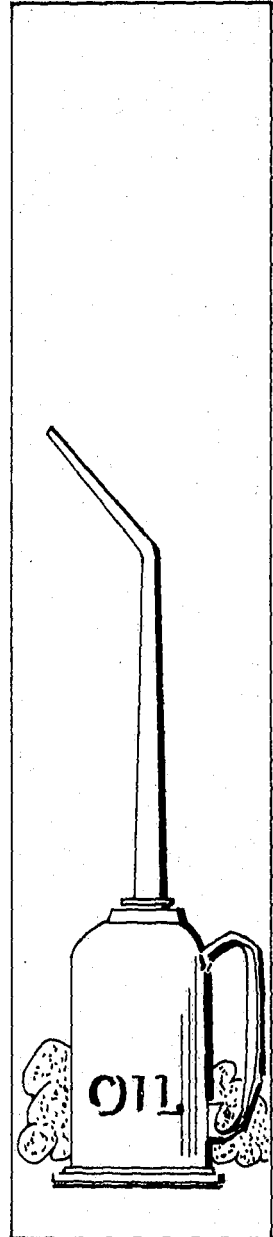

Small Appliances

VACUUM CLEANERS

There are three general types of cleaners, the cylinder type, Fig. 33, the canister type, Fig. 34, and the upright type, Fig. 35. The cylinder and canister types are always straight suction cleaners. The upright, Fig. 35, may have a revolving brush or roll to sweep or vibrate the rug.

I. Cleaner Refuses to Pick up Dirt

1. Cause: Cleaner bag may need emptying.

Remedy: Empty bag, turn wrong-side-out, and brush or clear; or discard paper collecting bag.

2. Cause: Improper adjustment of cleaner nozzle.

Remedy: Find the nozzle adjustment on your cleaner and adjust according to manufacturer's directions. On cleaners with a rotating brush or roll, the clearance between the cleaner nozzle and the rug should be the thickness of a half-dollar. Fig. 35.

3. Cause: Improper adjustment of cleaner brush.

Remedy: Hold machine with nozzle up, lay a ruler or piece of stiff cardboard over the nozzle. The bristles should not quite touch the ruler; a space of $1/32$ -inch is desirable. The adjustment is usually made by moving a pin, screw or lever at each end of the brush. Fig. 35.

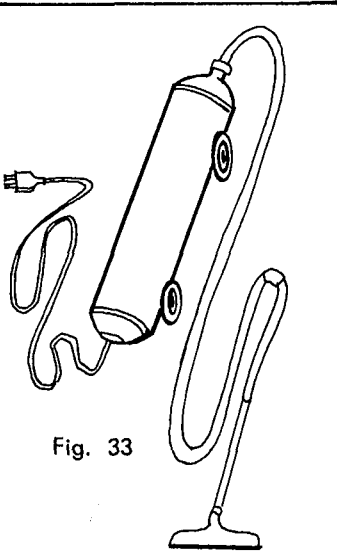

Fig. 33

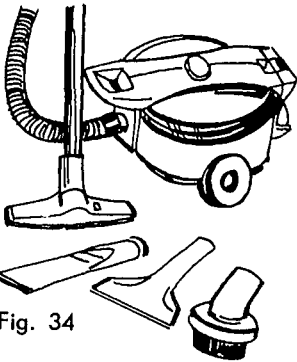

Fig. 34

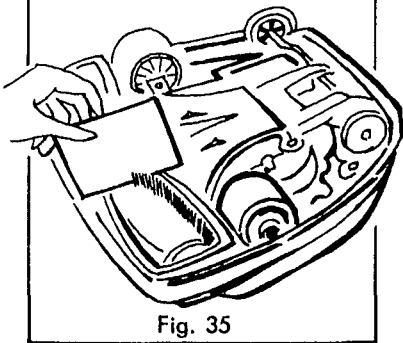

Fig. 35

Small Appliances

4. Cause: Broken belt or belt not revolving.

Remedy: Examine the belt. Fig. 35. Make sure it is around both the brush and motor shaft and is not tangled with hair and strings. If, after cleaning the brush, it still will not turn with the motor, the belt is probably stretched and should be replaced with a new belt.

- a. Slip belt off motor shaft.
- b. Remove brush and belt from cleaner.
- c. Slip new belt over brush.
- d. Place brush back in cleaner.

Caution: Be sure brush rotates with forward pull motion. If brush rotates in the opposite direction, remove belt from motor shaft, give half twist and replace. (Fig. 36)

II. Motor Does Not Operate

1. See motor trouble, Page 20.

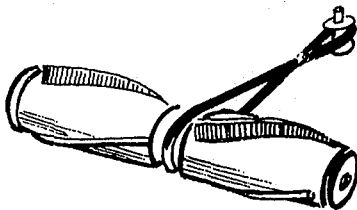

Fig. 36

Care, Cleaning and Operation

1. Lubrication: Most cylinder-type cleaners, Fig. 33, and many upright cleaners, Fig. 35, have bearings which are sealed and packed with grease at the factory. These types require no lubrication but should be inspected at least yearly by a competent serviceman. If any unusual noise develops in these cleaners they should be taken immediately to a serviceman, dealer, or manufacturer for inspection. Some upright cleaners of the type shown in Fig. 35 have oil holes. Oil these cleaners yearly with 3 or 4 drops of electric motor oil. An occasional drop of oil on the wheel bearings of the cleaner is desirable.
2. Do not use the cleaner to pick up metal objects such as pins.
3. Empty the bag after each general cleaning, or replace disposable bag when full.
4. Avoid picking up strings as these may wind around the brush or roll and cut the belt.

Small Appliances

HOUSEHOLD FANS

Household fans are made in a variety of types and sizes. There is little to get out of order provided fans are given proper care and lubrication.

I. Fan Vibrates Excessively

1. Cause: Bent or sprung blade.
Remedy: Test for a sprung blade as shown in Fig. 37. If metal, it may be sprung back into position.
2. Cause: Motor bearings damaged.
Remedy: Return to serviceman, dealer, or manufacturer for new bearings.

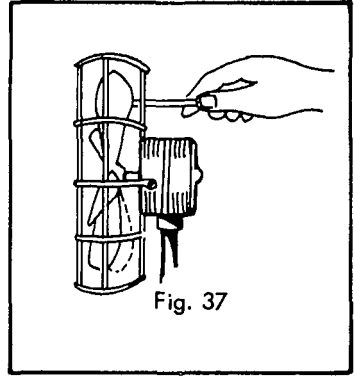

Lubrication of Fan Motors

There are usually two points of lubrication on fans. These are located at each end of the motor shaft.

1. If your fan is of the type shown in Fig. 39 and is in constant operation, it should be lubricated at least weekly with 2 or 3 drops of electric motor oil.
2. A fan which contains wick oilers is shown in Fig. 40. These oilers or cups should be filled yearly with vaseline or a light grade of cup grease.

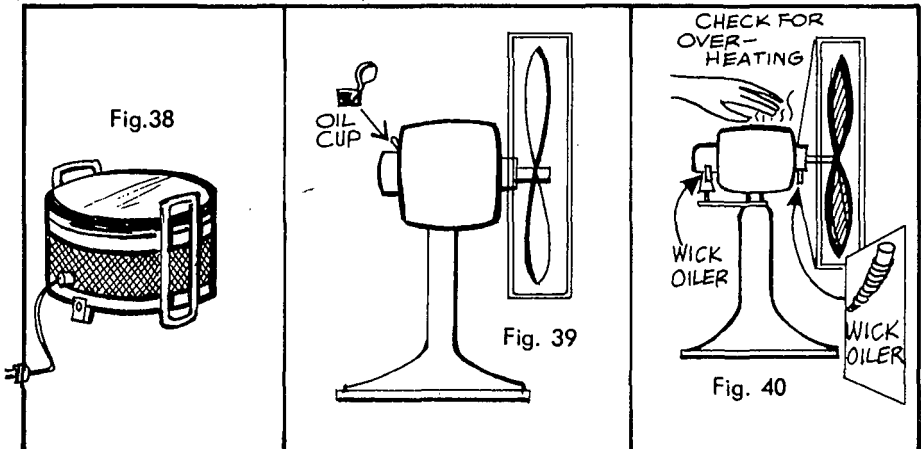

Small Appliances

MIXER

I. Motor Does Not Operate

1. See motor troubles, Page 20.

II. Beaters Strike Mixing Bowl

1. Cause: Beaters not placed firmly in their sockets.
Remedy: Push the beaters up until they are firmly in their sockets.
2. Cause: Improper adjustment of the motor head.
Remedy: Most mixers are provided with an adjustment to raise and lower the beaters in the mixing bowl. Fig. 41. Find this adjustment on your mixer, loosen the lock nut and turn the screw until the beaters just touch the bowl. Tighten the lock nut.

Care, Cleaning and Operation

1. Lubrication: Many mixers have sealed bearings which are packed with grease at the factory. Older mixers, as shown in Fig. 41, require lubrication. If the mixer is used frequently, it should be oiled every two weeks with 1 or 2 drops of light machine oil. If the mixer is not used often, it should be oiled once a month. The front cover should be removed at six-month intervals and the grease in the gear case examined. The old grease should be cleaned out and new grease added if necessary.
2. The motor should be wiped with a damp cloth after use. Do not get water in the oil holes or electrical parts.
3. The motor should be covered with a cloth or paper when not in use.

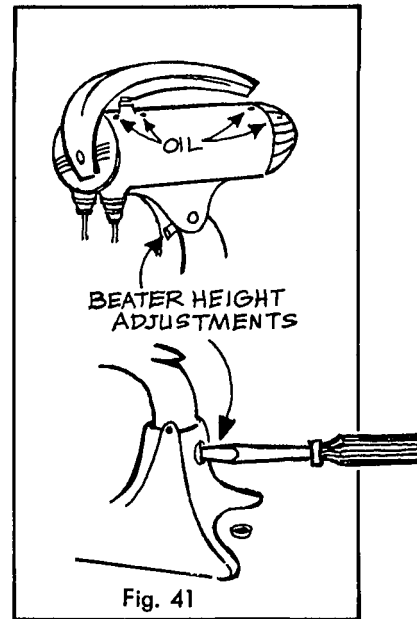

BLENDER

I. Blender Leaking

1. Cause: Not assembled correctly.
Remedy: Follow directions for assembling and tighten band.

Small Appliances

II. Motor Stalls

1. Cause: Too much food in container.
Remedy: Blend small amounts. Fig. 42

Care, Cleaning and Operation

To wash, half fill blender jar with warm water. Add a dash of detergent. Cover. Blend on low speed a few seconds. Rinse thoroughly. Leave jar uncovered until thoroughly dry. Wipe motor base with a damp cloth. Don't overload the container. Blender operates best if jar is only two-thirds full.

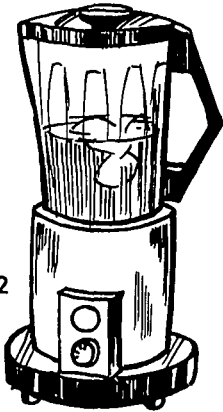

Fig. 42

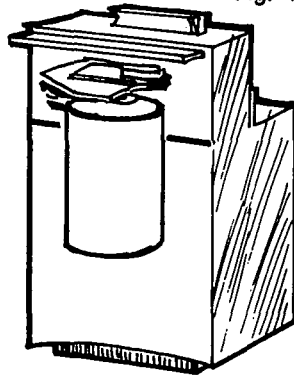

Fig. 43

CAN OPENER

I. Opener Will Not Cut

1. Cause: Can not put in properly.
Remedy: Follow directions and be sure the can is properly placed in the opener. Fig. 43

II. Opener Will Not Cut Completely Around Can

1. Cause: Dent in can.
Remedy: Open other end or start the cutter just beyond dent.

Care, Cleaning and Operation

Clean outer case with a damp cloth. Remove stubborn soil with non-scratching cleanser. Cutter wheel on most openers can be removed for cleaning.

Refrigerators

1. Refrigerator cabinet
2. Insulation
3. Frozen food and ice cube compartment
4. Meat tray
5. Interior light
6. Shelf space
7. Fresh vegetable and fruit tray
8. Compressor and motor
9. Door shelves
10. Butter keeper
11. Door shelf for eggs
12. Rubber door gasket
13. Temperature control

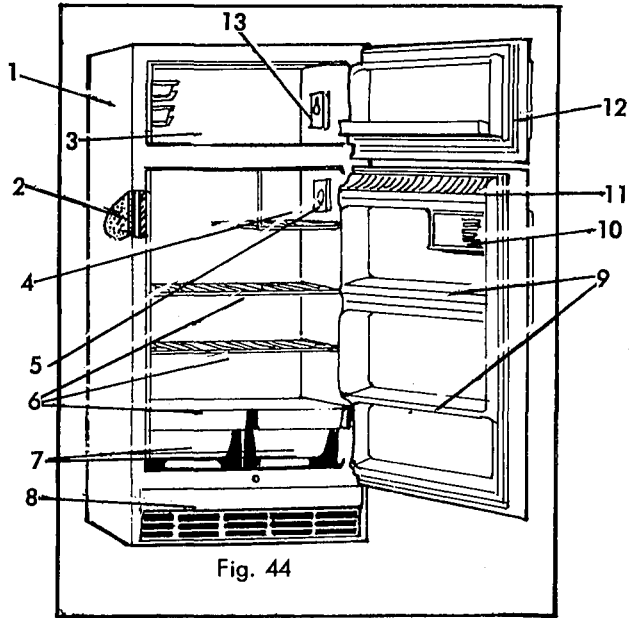

Fig. 44

I. Motor Will Not Run

1. Cause: Fuse blown; loose connection at wall outlet or motor; cord or plug needs repair.

Remedy: See Page 4, Fuses - Cords - Plugs.

II. Motor Runs too Much

1. Cause: Condenser dirty.

Remedy: Clean condenser once or twice a year with a long-handled brush or vacuum cleaner attachment (Fig. 45a). Condenser is usually located at the top back (Fig. 45b), or at the bottom of

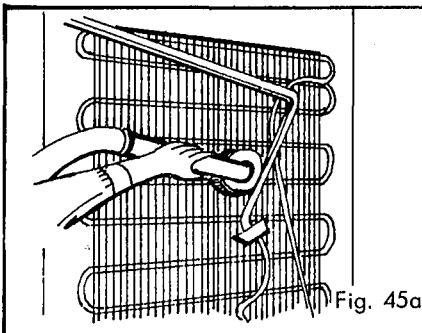

Fig. 45a

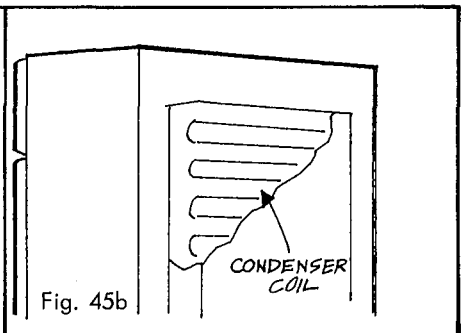

Fig. 45b

Refrigerators

the refrigerator. If necessary, pull refrigerator out from wall.

Caution: Always disconnect refrigerator from power supply before cleaning condensers.

2. Cause: Too much hot food in refrigerator.
Remedy: Let food cool before placing in refrigerator.
3. Cause: Door leaking air. Test by closing the door on a dollar bill or a piece of paper of the same thickness. Fig. 46. If you can pull the paper out easily, there is a poor fit at this point. Test at several points around the door.
Remedy: a. Adjust the door latch. Fig. 47. On some models this may require a serviceman.
b. Doors may need a new gasket. Fig. 48. The old gasket usually can be taken off by removing the screws around the door edges.
4. Cause: Door opened too frequently or allowed to stand open.
Remedy: Have all foods ready to place in the refrigerator before opening the door. Locate the refrigerator so that door opens conveniently to a nearby work surface. Fig. 49. Close the door immediately after the foods are placed inside.
5. Cause: Refrigerator improperly located.
Remedy: See that refrigerator is not too close to a range or too close to the wall or cabinets. Allow a 12-inch space above the refrigerator and a 4-inch space at the back and sides. Fig. 49.

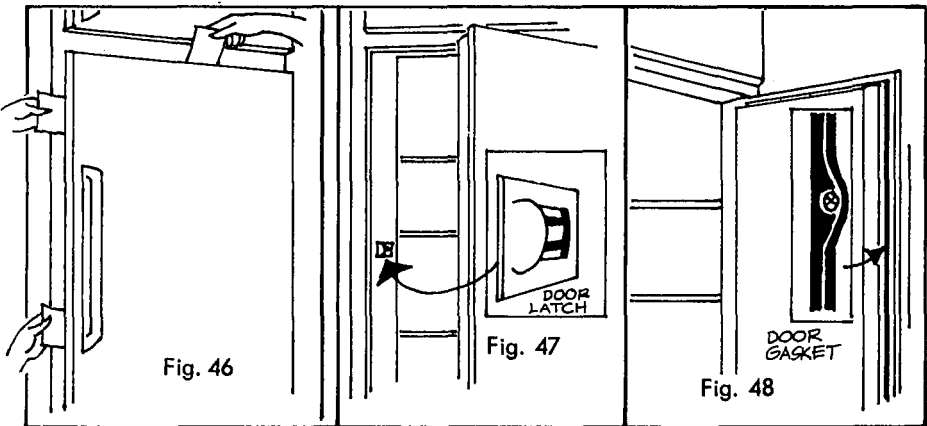

Refrigerators

III. Noisy Refrigerator

1. Cause: Refrigerator not level.
Remedy: Adjust leveling screws or place thin piece of wood under the legs. Metal discs may be obtained from dealer.
2. Cause: Food containers shake or rattle.
Remedy: Move containers so they do not touch each other or the cooling unit.
3. Cause: Loose parts.
Remedy: Tighten any loose bolts or screws.

IV. Motor Runs But Will Not Freeze Ice

1. Cause: Refrigeration unit not operating properly.
Remedy: Call serviceman.

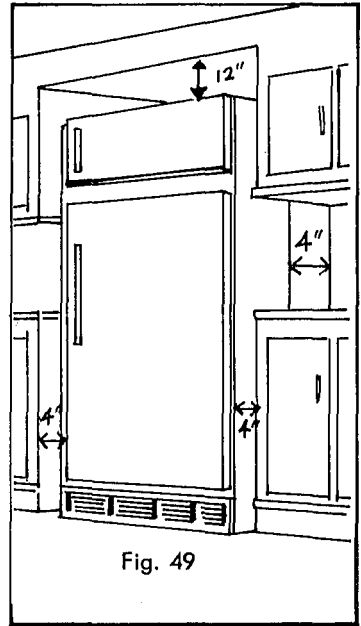

Fig. 49

V. Freezing Unit Collects Too Much Frost or Moisture Condenses in Cabinet

1. Cause: Door leaking air.
Remedy: Adjust door latch or replace rubber gasket, if worn.
2. Cause: Uncovered foods in refrigerator.
Remedy: Cover all foods.
3. Cause: Incomplete defrosting.
Remedy: Defrost completely; see directions given under "Care and Cleaning."
4. Cause: Temperature too low in refrigerator.
Remedy: Set temperature control to maintain 35°F. to 45°F.

VI. Foods Will Not Keep

1. Cause: Improper storage or too high temperature.
Remedy: Remove vegetables from packages, discard wilted leaves and spoiled parts, wash thoroughly, drain and store in covered pan or hydrator in bottom of refrigerator. Unwrap meat, cover with waxed paper, and place in the coldest part directly under freezing unit. Keep temperature between 35°F. to 45°F. Defrost when frost becomes ¼-inch thick on freezing unit unless it automatically defrosts.

Refrigerators

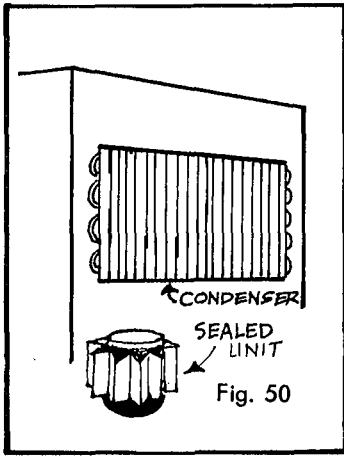

VII. Odor in Cabinet

1. Cause: Uncovered foods.
Remedy: See that all foods with a strong odor are covered.
2. Cause: Cabinet needs cleaning.
Remedy: Clean thoroughly according to directions under "Care and Cleaning."
3. Cause: Mechanical trouble.
Remedy: Call serviceman.

Care, Cleaning and Operation

1. Lubrication: Sealed units as shown in Fig. 50 require no oiling, as oil has been sealed in the unit at the factory.
2. Defrost whenever the frost on the freezing compartment exceeds $\frac{1}{4}$ -inch unless it automatically defrosts. Avoid prying trays or frost loose with a sharp instrument. Always melt the frost, by turning control switch to defrosting, or turning off the electricity. The process may be speeded by leaving the door open while defrosting, by filling pans with hot water, or by directing the air from a fan into the compartment.
3. After defrosting, clean the entire cabinet interior, including freezing compartment, with a mild solution of warm water and baking soda. Do not use soap on the inside as it may cause an odor. Wipe up spilled foods immediately. Avoid the use of coarse cleaning powder on the inside or outside. If shelves become stained or rusted, clean with fine steel wool. Periodic cleaning is also essential for automatically defrosting refrigerators.
4. Clean the outside of the cabinet with mild soap and warm water. The surface, if enameled, may be waxed two or three times a year for protection. Nicks and scratches should be painted with touch-up enamel to prevent rust.
5. Avoid touching the gasket when opening and shutting the door. Grease from hands softens rubber.
6. After setting control for fast freezing, and freezing is completed, be sure to turn control to normal setting.

Ranges

- 1.-Pilot lights
- 2.-Automatic clock
- 3.-Pushbutton switches, surface units
- 4.-Appliance outlets, normal and timed
- 5.-Timer (sometimes called minute timer or reminder)
- 6.-Oven temperature controls
- 7.-Oven
- 8.-Storage drawer
- 9.-Recessed toe space
- 10.-Warmer or second oven
- 11.-Large surface unit
- 12.-Small surface units
- 13.-Deep-well cooker
- 14.-Lamp switch
- 15.-Lamp
- 16.-Drip pan
- 17.-Bottom oven unit
- 18.-Broiler unit
- 19.-Sliding shelves

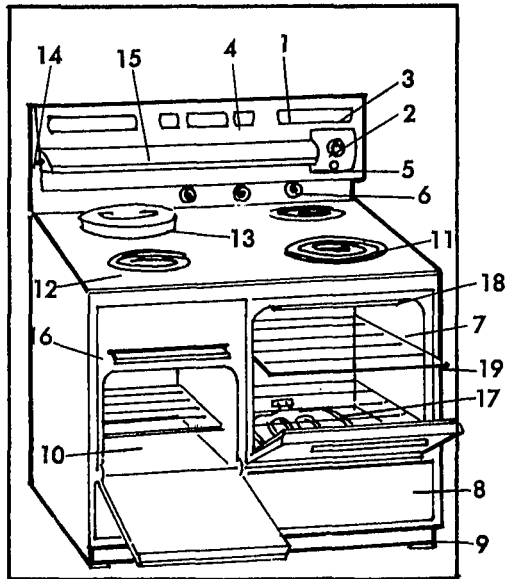

Fig. 51

ELECTRIC RANGE

I. Surface Unit Will Not Heat

1. Cause: (a) Range plug disconnected.
(b) Range or main fuse blown.
(c) Power off temporarily.

Remedy: If all surface units are not heating, see if range plug is pushed firmly into receptacle. Fig. 52. If this is not the cause, try lights in other parts of the house to see if fuse is blown or power is off. Replace range or main fuses if blown. Fig. 53. If main service panel is circuit breaker type, reset main or range circuit breaker.

Fig. 52

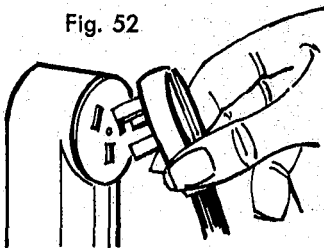
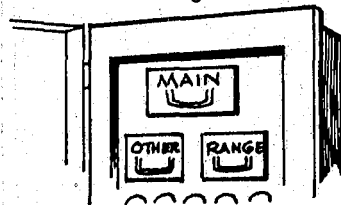

Fig. 53



Ranges

2. **Cause:** Loose connection or broken wire in unit.
Remedy: If wire is broken at terminals, clean end of wire and make proper connection. If the wire is broken any place except at terminals it should be repaired by a serviceman.
3. **Cause:** Switch defective.
Remedy: Call serviceman.

II. Oven Will Not Heat

1. **Cause:** Same as for surface units. See I (2). Many times the terminals of the oven heating units are not pushed firmly into the receptacles. Some models have permanently attached heating units.

Remedy: Same as for surface units. Push heating units firmly into receptacle. Fig. 54.

2. **Cause:** Timer set at "OFF" or "AUTOMATIC" position.
Remedy: See that timer is set at "Manual" position.

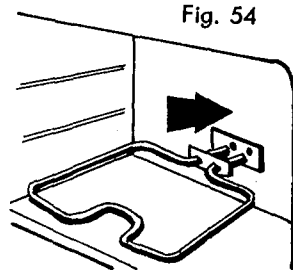

III. Oven Heats Improperly

1. **Cause:** Thermostat set wrong or thermostat out of adjustment.
Remedy: Set thermostat for desired cooking temperature. If temperature is still incorrect, consult serviceman.
2. **Cause:** Oven door opened too often while baking.
Remedy: Watch the clock and do not open door until required cooking time is completed.

IV. Oven Browns Unevenly

1. **Cause:** Range not level.
Remedy: Test by placing a level or a large pan of water on oven rack. To level range, place wooden blocks under legs, or discs may be secured from dealer.
2. **Cause:** Oven door fits improperly.
Remedy: Check fit with a piece of paper. The door should fit tightly at the top but have 1/8-inch space at the bottom edge. The adjustment may require a serviceman.
3. **Cause:** Utensils placed incorrectly in oven.
Remedy: Place pans in oven so that air can circulate around them. Stagger pans; do not place one pan directly over another.

Ranges

4. **Cause:** Bent, warped, or unevenly discolored utensils.
Remedy: See kitchen utensils, Page 43. A dark surface absorbs more heat than a bright one. For biscuits, use a baking sheet. A pan with deep sides may be used upside down.
5. **Cause:** Oven door opened while baking.
Remedy: Do not open door until cooking time is completed.

V. Convenience Outlet on Range Will Not Operate

1. **Cause:** Fuse loose or blown.
Remedy: A plug type fuse is located in the range. It may be found at the back, in the front, or under a surface unit. It may be necessary to remove the drawer to find fuse.

Care, Cleaning and Operation

1. Clean heating elements by burning off any spilled food and brushing with a soft brush. Never scrape or use water to clean unit.
2. Keep the 4 S's away from the wires of an open unit - salt, soda, soap, and sugar.
3. Avoid using a higher heat than necessary.
4. Rotate the use of the surface units, using the largest unit only when using a large pan.
5. Keep the drip pans beneath the surface units clean to prevent burning of wires leading to surface units. In order to clean, it may be necessary to lift the surface unit. On some models this is not possible.
6. Use utensils with flat bottoms and tight fitting lids. When a large utensil must be used, protect the porcelain enamel around the surface with a heavy asbestos sheet larger than the utensil with a hole in the center the size of the unit.
7. Clean the porcelain top after it is cool with warm soapy water, or whiting. Wipe up lemon, vinegar, or other acids immediately.
8. Clean oven with soap and water or with commercial oven cleaners used according to the manufacturer's directions. Leave door open until oven is cool. Never store food in oven. Avoid putting exceptionally heavy objects on oven door or surface units.
9. Be sure the deep well cooker has water in it before you turn on the switch. Always remove the pan and use a rack when baking in a deep well cooker.
10. Keep broiler pan clean and stored in utensil drawer except when broiling.

Ranges

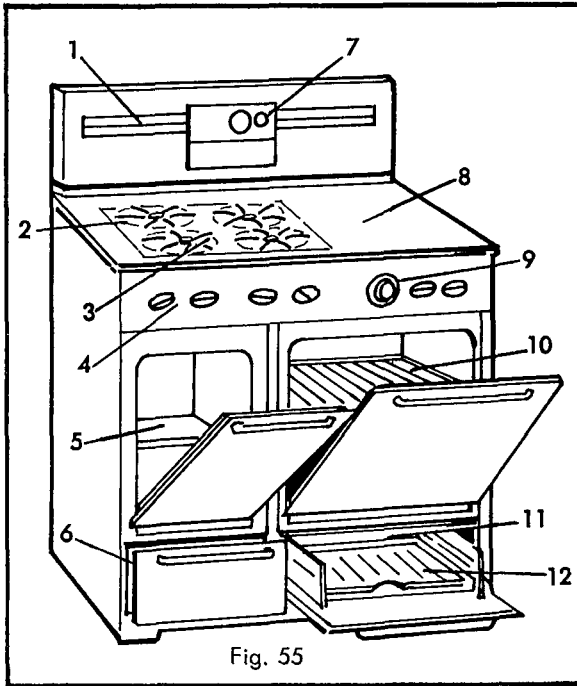

Fig. 55

GAS RANGE

- 1.-Flue Deflector
- 2.-Top Burner
- 3.-Burner Pilot
- 4.-Top Burner Control
- 5.-Storage
- 6.-Storage
- 7.-Backguard, Oven Timer
- 8.-Main Top
- 9.-Oven Thermostat
- 10.-Oven Rack
- 11.-Oven Burner & Pilot
- 12.-Broiler Pan

I. Excessive Surface Temperature

1. Cause: Incorrect fitting of oven door.
Remedy: Adjust oven door for proper fit.

II. Oven Too Hot or Too Cold

1. Cause: Burner over or under gassed.
Remedy: Adjust burner flame until approximately $\frac{3}{4}$ -inch maximum flame.
2. Cause: Thermostat out of calibration.
Remedy: Call serviceman. If thermostat will not hold calibration replace thermostat.

III. Gas Odors from Lighted Oven

1. Cause: Poorly adjusted burner or pilot.
Remedy: Adjust burner and pilot. If odor persists, call serviceman for possible gas leaks.
2. Cause: Stoppage in flue.
Remedy: Check flue for obstructions.

- IV. Top Pilot Outage. Pilot outage can be caused by many things—some mechanical, others non-mechanical. The location of the range in the kitchen is important since an open window or door can

Ranges

admit a draft which could put out pilot flame.

1. Cause: Improper adjustment of top burner. Too much air or too much gas.
Remedy: Readjust top burner so that ignition does not put out pilot flame.
2. Cause: Lighting jet smothers pilot flame.
Remedy: Decrease gas input to top burner.
3. Cause: Dirty pilot valve.
Remedy: Clean pilot valve to eliminate dust and dirt particles.

V. Top Burner Fails to Light

1. Cause: Ignition tubes out of position.
Remedy: Check ignition tubes for proper alignment.
2. Cause: Ignition tubes may need cleaning.
Remedy: Wash ignition tubes.
3. Cause: Burner may require air and gas adjustment.
Remedy: Adjust air and gas mixture or call serviceman.
4. Cause: Burner pilot is out.
Remedy: See Item IV above.

VI. Oven Pilot Outage

1. Cause: Oven burner flame putting out pilot.
Remedy: Relocate pilot or call serviceman.
2. Cause: When oven pilot will not light, safety valve is not holding open.
Remedy: Call serviceman to check safety valve and thermocouple.

VII. Oven Burner Failure (Match-lit oven)

1. Cause: Dirty burner ports.
Remedy: Clean burner with wire pipe cleaner or wire brush.
2. Cause: Burner may be out of line.
Remedy: Check burner for proper alignment.

(Matchless oven)

3. Cause: Oven pilot is out.
Remedy: Light pilot and, in 60-90 seconds, the oven should turn on. If this does not work, make sure that the thermocouple fitting adjacent to the pilot light is free from foreign material. This connection should be bright and clean. If the burner still fails to light, call serviceman to check safety valve and thermocouples.

VIII. Noisy Operation

1. Cause: Burner over-rated.
Remedy: Reduce gas input to oven burner or call serviceman.

Ranges

Care, Cleaning and Operation

The Enamel—

1. Cool range before washing. Sudden change in temperature will cause enamel to "craze."
2. If acid food such as tomato juice, lemon juice, onion juice, or milk is spilled on range, wipe it off with a dry cloth to prevent enamel from getting dull spots.
3. Use soda to remove any stubborn spots from enamel. Avoid use of harsh, gritty abrasives.
4. Wash with soap and water, rinse and dry.
5. Use chromium or silver polish on chromium.

Surface Burners —

1. Clean porcelain and chromium burners and drip trays with a soap and water or a baking soda solution of 1 tablespoon soda to 1 quart water. This cuts grease and helps to remove stubborn spots.
2. Rinse well, then turn burners upside down to drain thoroughly and dry.
3. Inspect port holes to see if they are open.
4. Use only a fine wire brush, pipe cleaner or a wire to clean port holes.

Oven—

1. Wash inside of oven with soap and water, rinse and dry. Use a mild abrasive or soda to remove stubborn spots.
2. Clean racks with fine steel wool.
3. If food runs over, let it char before trying to remove it.
4. Saturate a cloth with household ammonia and allow to stand a few hours or overnight. The fumes will loosen grease and spills. Remove racks and wash with soap and water; rinse, then dry.
5. An insulation bottom should not be immersed in water.
6. Glass windows in oven door should be cleaned frequently with a weak solution of household ammonia and water, or soap and water. Rinse and dry thoroughly.

Broiler—

1. After food is removed, allow broiler grill and pan to cool 5 to 10 minutes. Sprinkle with soap flakes and fill with hot water. Wash, then rinse dry.
2. When broiling compartment is under the oven, the broiler pan should be removed when the oven is in use.

Washing Machines

WRINGER TYPE

I. Motor Will Not Operate

1. Cause: Fuse blown, loose connection at wall outlet, or cord or plug needs repair.

Remedy: See Page 4, Fuses-Cords-Plugs. Blowing of fuses may be caused by starting machine when the motor is cold, when the agitator is in the "on" position, or when the machine is already loaded. An overloaded machine can also blow fuses.

2. Cause: Motor troubles.

Remedy: See motor troubles, Page 19.

3. Cause: Machine cold; oil stiff (not a problem on most automatic washers).

Remedy: Move into a warm room one to two hours before using, or fill tub with warm water.

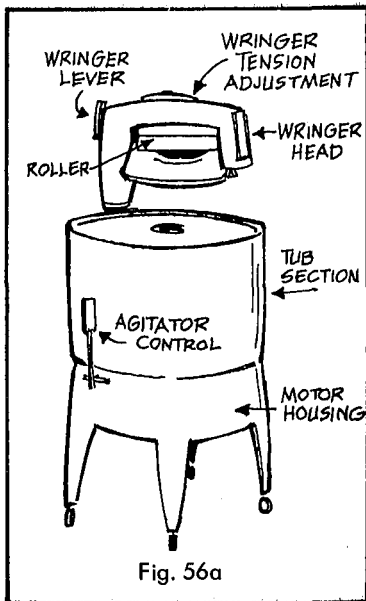

Fig. 56a

II. Wringer Does Not Operate Properly (Wringer Type, Fig. 56a)

1. Cause: Wringer lever not turned completely to "ON" position.

Remedy: Move lever to "ON" position.

2. Cause: Improper pressure on wringer roll.

Remedy: Adjust for correct pressure or tension. Fig. 56a. There are other wringer troubles of a mechanical nature that cannot be repaired in the home. The wringer can be easily lifted from the machine and taken for repair to a serviceman or manufacturer.

III. Agitator Does Not Operate Properly

1. Cause: Agitator not in place. On some models, cap screw at top of agitator may be loose.

Remedy: Keep cap screw on top of agitator tight. Keep agitator pushed down in place. See that dirt has not collected underneath the agitator.

Washing Machines

2. Cause: Agitator level not turned completely to "ON" position.
Remedy: Move lever to "ON" position.
3. Cause: Drive coupling loose.
Remedy: Tighten set screws on drive coupling at motor end and agitator shaft end. Fig. 56b.

IV. Noisy Washing Machines

1. Cause: Parts loose or worn.
Remedy: Tighten all bolts and screws. Keep all parts repaired.
2. Cause: Machine not level.
Remedy: Place thin wood under legs.
3. Cause: Spinner vibrating because it is unevenly loaded.
Remedy: Pack clothes evenly in spinner as it is filled.

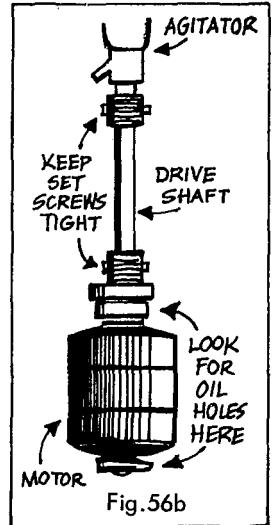

Fig. 56b

Care, Cleaning and Operation

1. Lubrication: With most electrically driven washers, lubrication has been provided at the factory for the life of the washer. However, examine the wringer head and motor (Fig. 56a) for oil holes. Oil motor monthly, with 2 or 3 drops of electric motor oil. Oil casters frequently.
2. For safety with an electric washer, be sure that a ground wire connects the frame to a metal water pipe or ground rod. Stand on a dry floor and be sure hands are dry when you connect the plug in order to prevent shock. Always check safety pressure release on wringer before using.
3. Be sure the water level is even with the mark indicated on the inside of the washer or on the agitator. If water is allowed to get too high, it may drain into the gear case where it will do serious damage. If it is too low, a rubbing, scraping sound may be heard.
4. Avoid overloading the machine as it will strain the mechanism of the washer and overheat the motor as well as fail to get the clothes clean. The clothes should circulate freely in the water. Overloading causes more washer problems than any other factor.
5. Wash by the clock. If clothes are washed too long, dirt from the water goes back into the clothes, electricity is wasted,

Washing Machines

- and the machine gets unnecessary wear. Allow 5 to 10 minutes for slightly soiled cotton and linen, 10 to 12 minutes for very soiled cotton, and 2 to 4 minutes for wool, silk, and synthetics.
6. Release the pressure on the wringer rolls immediately after each use.
 7. Pumps: If the washer contains a pump, remove the cover from the drain and clean out the pump, if it becomes clogged. Drain all the water from the hose after each use.
 8. Periodically, remove the agitator and clean the underside and the post thoroughly. Use care in handling the agitator to avoid nicks and scratches which will cause undue wear on clothing and eventually necessitate a new agitator. Clean the inside and outside of the tub with hot soapy water, rinse, and dry. Rub stubborn spots with whiting.
 9. Most automatic washers are self cleaning; however, they should be run through an extra cycle after machine has been used for starching or tinting. When machine is used for tinting, cover lid with moisture-proof paper.
 10. Wash the rollers on wringer in warm, soapy water, rinse and dry. If necessary to use kerosene to remove stains, wash off with soapy water.
 11. Store in a dry place away from sun and heat. Leave lid slightly open. Leave drain valve open. Cover against dirt and dampness. You can make or buy a dust-proof cover that slips over the entire machine.
 12. Disconnect cord, wipe dry beginning at the motor end, and wind loosely over the hook on the side of the washer. Never leave cord lying on the floor.
 13. In using a spin dryer, never remove cover while machine is operating.

AUTOMATIC WASHER

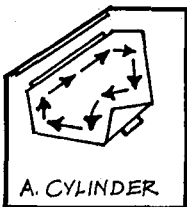

Fig. 57

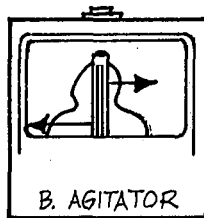

Fig. 58

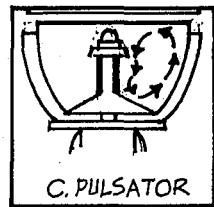
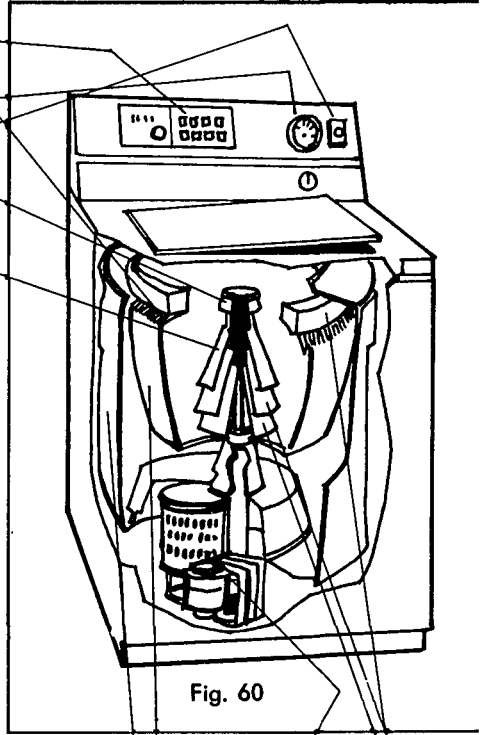
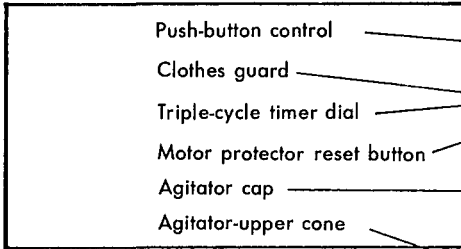

Fig. 59

Washing Machines



I. Water Leaks Around Door of Cylinder Type

1. Cause: Worn gasket.
Remedy: Rotate or replace door gasket.

II. Hot or Cold Water Does Not Run into Washer

1. Cause: Faucet valves closed.
Remedy: Open faucet valves.
2. Cause: Kink in hose.
Remedy: Straighten hose.
3. Cause: Solenoid valve faulty.
Remedy: Call serviceman.
4. Cause: Switch faulty.
Remedy: Call serviceman.

III. Water Does Not Drain From Washer

1. Cause: Strainer stopped with lint, etc.
Remedy: Remove strainer and clean.
2. Cause: Faulty water pump.
Remedy: Call serviceman.
3. Cause: Kink in discharge hose.
Remedy: Straighten hose.

IV. Washer Vibrates

1. Cause: Washer not level.
Remedy: Adjust leveling legs.

V. Washer Motor Does Not Run

1. Cause: Fuse blown or cord disconnected.
Remedy: Replace fuse or connect cord.

VI. Tub Spinning Slowly

1. Cause: Suds lock caused by too much detergent.
Remedy: Use less detergent.

Clothes Dryers

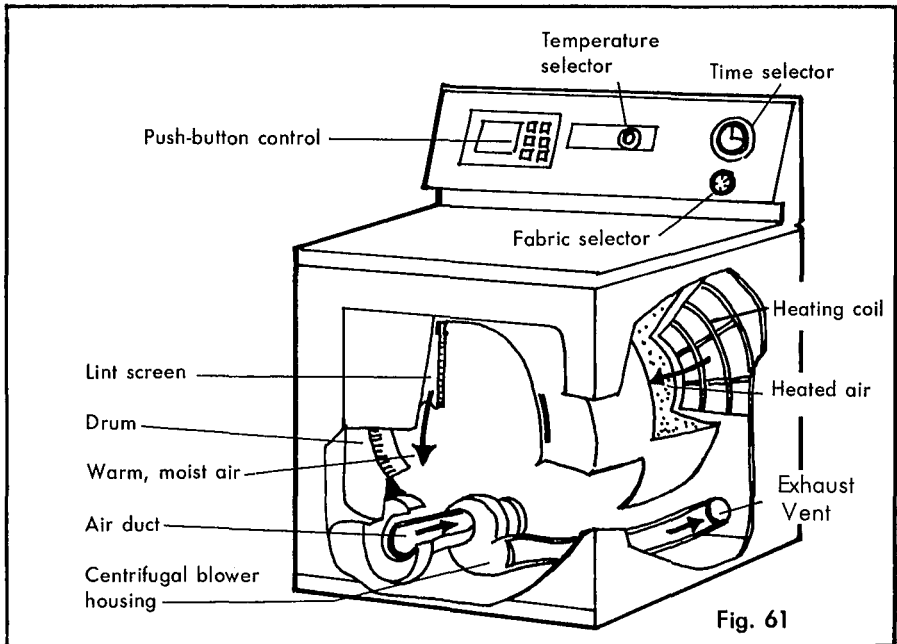

I. Clothes Do Not Dry in Proper Time

1. Cause: Dryer overloaded.
Remedy: Do not put too many clothes in dryer.
2. Cause: Lint trays stopped.
Remedy: Clean lint trays (should be done after day's use).
3. Cause: Dryer improperly vented or vent obstructed (vertical type.)
Remedy: Remove obstruction from vent or see that dryer is vented to outside.
4. Cause: Condenser not functioning.
Remedy: Check to see that cold water is turned on.
5. Cause: Thermostat not functioning properly.
Remedy: Consult serviceman.
6. Cause: Air intake obstructed.
Remedy: Remove obstruction.
7. Cause: Heating unit disconnected or faulty.
Remedy: Call serviceman if heating is faulty.
8. Cause: Clothes too wet when put in dryer.
Remedy: Check washer to see if spinner is operating properly.

Clothes Dryers

II. Dryer Motor Runs But Cylinder Does Not Turn

1. Cause: Belt broken or off.
Remedy: Replace belt.

III. Dryer Does Not Operate At All

1. Cause: Fuse blown or plug disconnected.
Remedy: Check fuses and plugs.
2. Cause: Faulty dryer switch.
Remedy: Consult serviceman.

IV. Clothes Damaged Because of Excess Heat

1. Cause: Thermostat not set on proper temperature for the type of clothes in dryer.
Remedy: See instruction manual for proper temperature to use.
2. Cause: Thermostat out of adjustment.
Remedy: Consult serviceman.

Care, Cleaning and Operation

1. Clean lint screen frequently. This may require cleaning after each load if articles lose lint readily.
2. When drying starched clothes, start with cold drum. Use a cloth or brush and cold water to remove any particles of starch after drying heavily starched articles.
3. **Do Not:** use dryer for drying articles treated with flammable solvents, or articles made of rubber or other materials that would melt or dissolve under heat.
4. Leave door slightly open after each use. Be sure Time Control is in "off" position.
5. Clean exterior with a damp cloth.

Pressure Cooker

1. After each use, clean pressure cooker (Fig. 62) as you would clean any aluminum utensil. Wipe inside of lid with a damp cloth. Handle lid carefully and never put in water. Leave lid off the cooker when not in use; storing it closed causes the aluminum to pit and discolor.

2. Take the safety valve apart and clean the parts often. Fig. 63. Keep the ball clean with fine steel wool or vinegar.

Caution: Unless this is done you have no safety protection. Safety valve should "pop off" between 16 and 20 pounds' pressure; if it does not "pop off" force spring down to loosen slightly. A new spring may be needed. Clean pet cock (Fig. 62) with fine steel wool.

3. **Caution:** Never open cooker without first making sure that the gauge registers "zero," and that the pet cock is open and all steam escaped (Fig. 62). Cool gradually and always open lid away from you.

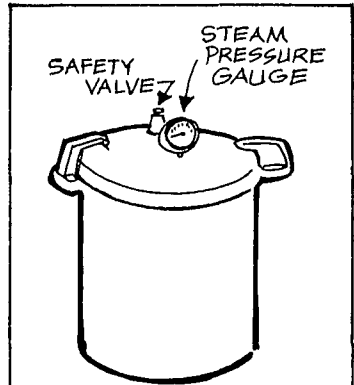

Fig. 62

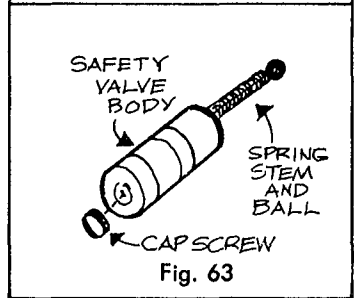
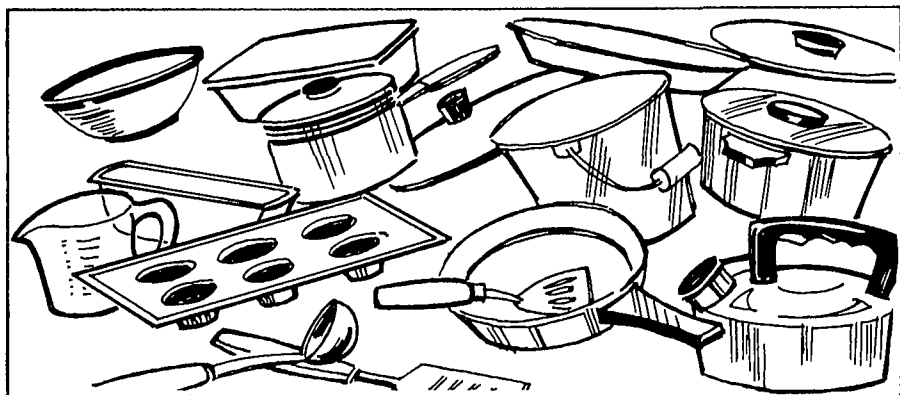

Fig. 63

4. Keep right amount of water in the cooker.
5. Always keep opening to gauge clean.
6. Have pressure gauge (Fig. 62) tested whenever possible. If it fails to return to "zero," it should be adjusted by the manufacturer, or replaced with a new gauge.
7. If lid has a tendency to stick, rub edges of lid and cooker with unsalted fat before sealing. Never pry lid loose with a metal object as it will damage the seal. A strong piece of wood may be used. Sometimes removing the pet cock will allow entrance of air and the lid can be more easily removed.
8. If the cooker leaks steam so that the gauge will not register, send the lid to the manufacturer. If only a small leak occurs around the lid, smooth the edges of the lid and cooker with emery cloth or fine steel wool. If the lid has a rubber gasket which has become worn, replace it. If it leaks at the pet cock, order a new pet cock from the manufacturer.
9. Pressure saucepan - Reduce pressure by placing pan in cold water. Remove weight when pressure is down.

Kitchen Utensils



1. Avoid leaving food standing in an aluminum vessel longer than necessary. Minerals in food cause pitting of aluminum.
2. To brighten a stained and discolored aluminum pan, boil an acid, such as vinegar, in it and rub with fine steel wool and whiting. Certain foods such as sour milk, tomatoes, rhubarb, tart apples, or plums cooked in aluminum will brighten it. These foods will be safe for eating. Clean discolored brass or copper by rubbing it with hot buttermilk or hot vinegar and salt, or commercial brightener, and washing thoroughly. Never scrape aluminum with a metal object.
3. Dry iron and tin utensils thoroughly and store uncovered in a dry place to prevent rusting. If a utensil must be stored for some time, give it a protective coat of unsalted fat. Do not scour tin pans. This will remove the tin coating and cause rusting.
4. Do not subject enamel, agate ware, or glass to sudden changes of temperature, to blows, or to scraping with sharp objects. Do not place hot glass on a cold surface or touch it with a wet cloth.
5. Clean chromium and nickel, which are soft metals, with soap and water. For stubborn stains, use Spanish whiting. Never use coarse scouring powder.
6. Clean galvanized buckets and garbage pails with coarse scouring powder. Scald garbage pails and air in the sunshine to prevent odors.
7. To prevent dents in utensils, store them in an easy-to-reach place so they can be removed without moving others. Make racks for storage of pots, lids, pie pans, thin baking sheets, and trays.

Knives

1. Sharpen knives often. A tapered steel rod, oil stone, or grindstone can be used. See that the cutting edge always leads when sharpening. Fig. 64.
2. To keep knives sharp, cut food on wooden cutting board, not on a metallic or enameled surface. Avoid leaving knives in hot water. Store in a wooden wall rack, or a holder made by tacking a leather strip to the wall. Never store knives loose in a drawer as the edges become dulled.

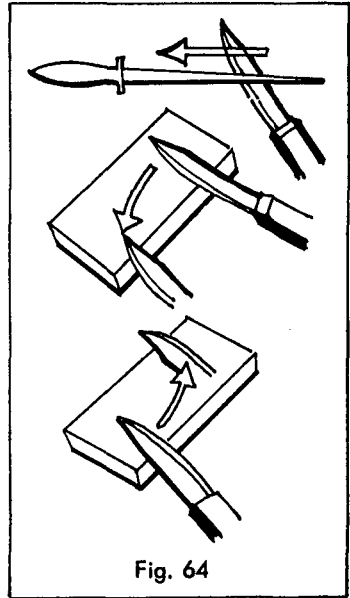
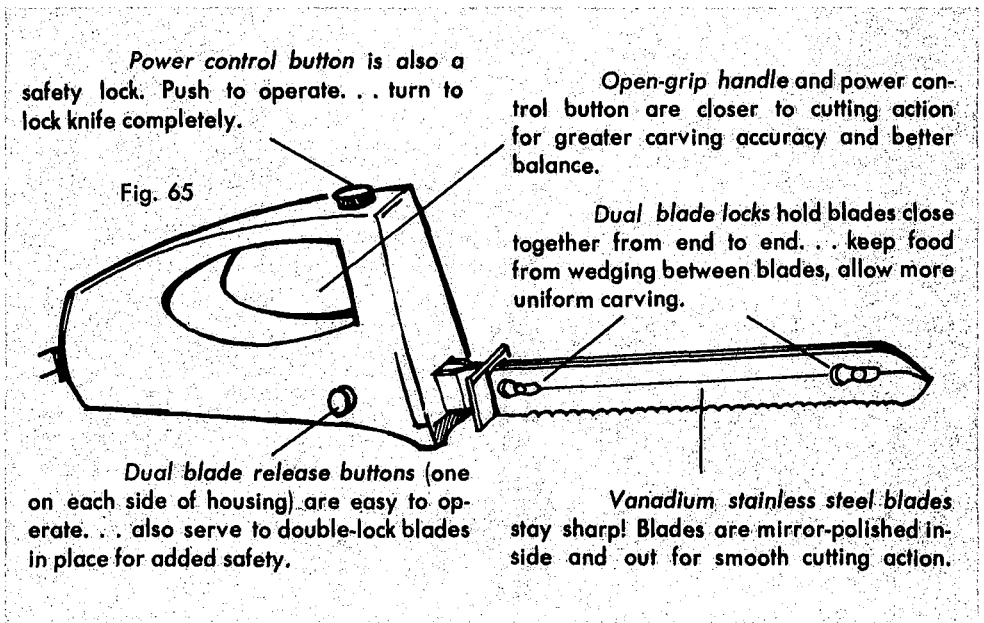

Fig. 64

ELECTRIC SLICING KNIFE Fig. 65.

Wash blades in sudsy water as you would any fine carving knife. Rinse and dry thoroughly. Wipe motor handle with damp cloth. Dry. With normal use, the blades should maintain their cutting ability. Blades must not be sharpened at home.



GROUNDS FOR PORTABLE EQUIPMENT

How NOT to Get Shocked

How can a person get a shock from using an electric drill, or other tool or appliance?

First, there must be a defect in the tool. Because of this defect, electric current can make the metal frame of the tool alive with electricity.

Second, the person using the defective tool must be in contact with a ground.

This does not necessarily mean the user must be in direct contact with the ground (earth). If his body contacts a water pipe, a metal part of the heating system or any other metal object, the current will flow through his body, then through the metal object to the ground.

Another way to get a possibly fatal shock is through use of defective electrical equipment which makes contact with a second piece of faulty electrical equipment. For example, if a housewife is using a defective vacuum cleaner and touches the metal standard of a defective floor lamp, her body becomes the pathway for the stray current between these two pieces of defective equipment.

Be sure all electrical tools (drills, saws, sanders, etc.) and electrical appliances (washing machines, dryer, etc.) are grounded. You never know when an electrical tool or appliance becomes defective.

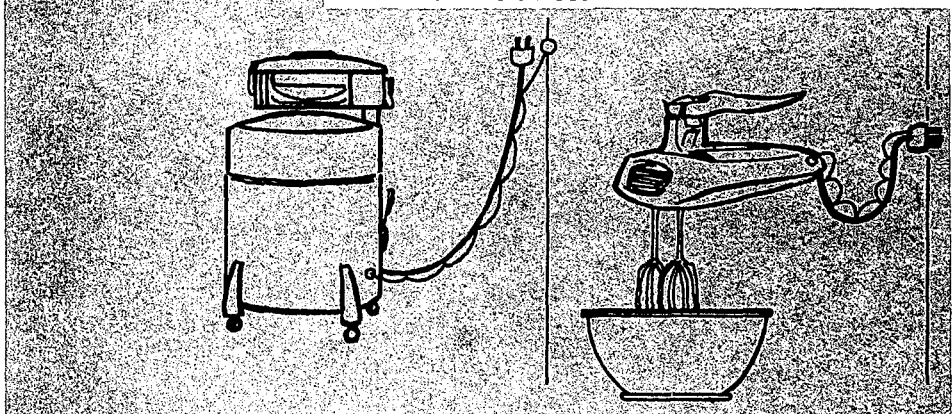
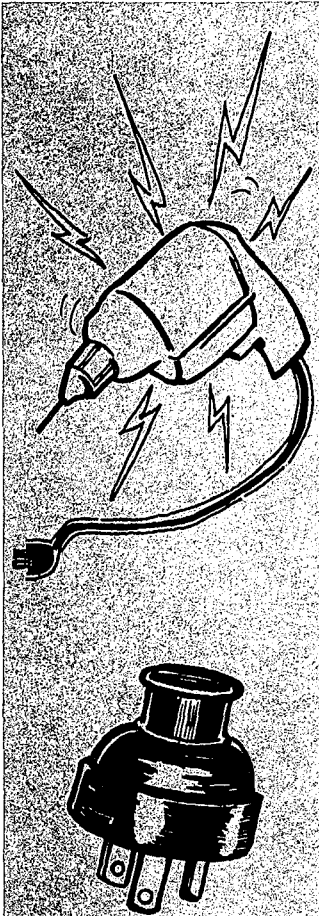

Connecting a two conductor cord to a 2-wire circuit: Attach one end of a No. 14 wire to the metal frame of tool and the other end to the receptacle plate screw, water pipe or other grounded object.

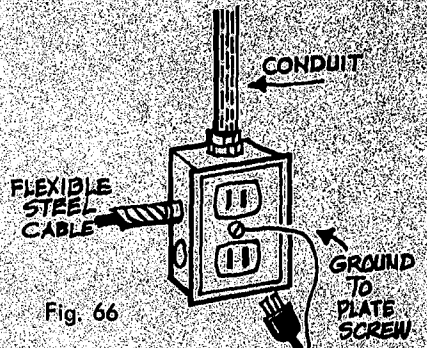

Fig. 66

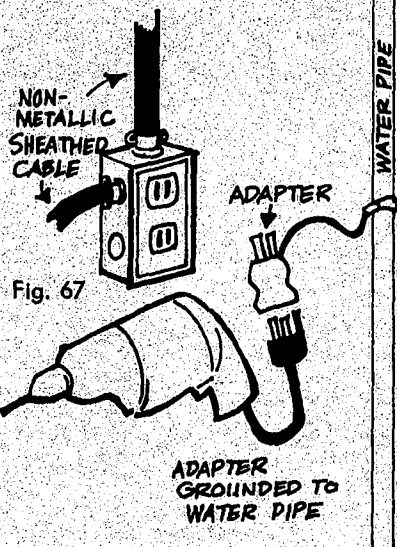

Fig. 67

Connecting a three conductor cord to a 2-wire circuit: If the circuit wiring has a conduit or flexible armored cable, connect the green conductor on the adapter to the receptacle plate screw. If non-metallic cable is used in the circuit wiring, fasten the green conductor to a water pipe or other grounded object.

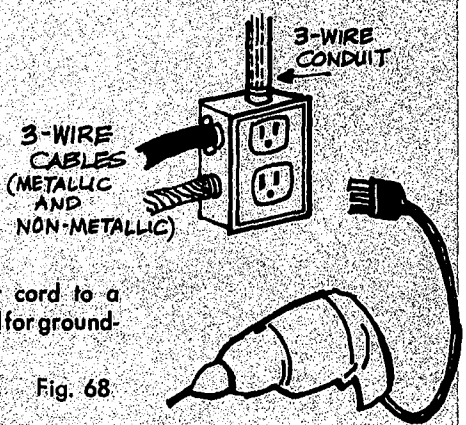

Fig. 68

Connecting a three conductor cord to a 3-wire circuit is the ideal method for grounding all your equipment.

Most new electrical tools and equipment now use a three-conductor cord. If a defect develops and the appliance is connected to a 3-wire, 120 volt electrical circuit, the stray current will use this third wire rather than the user's body, because this wire is the path of least resistance to earth.

SAFETY WITH ELECTRICITY

“Play it Safe” — Here Are Some Rules:

Main Switch: Know where the main switch is located and keep the space clear so you can reach it quickly in an emergency. Before you make any repairs pull the main switch to cut off the current. It is a good idea to keep a flashlight near the switch box.

Fuses: When something goes wrong, fuses stop the hazard by turning off the current. Be sure you use the right size fuse for the circuit. Don't be so foolish as to put a penny under a blown fuse. Be sure to keep a supply of extra fuses of the correct sizes.

Bare Wires: Never touch a bare wire or any metal that is touching a bare wire—and don't touch electrical fixtures, switches or appliances when you are wet.

Flying Kites: Kites should never be flown near electric power lines. The kite string might cause a short circuit between the line and the ground.

Shocks: Any switch, light appliance or piece of equipment which gives a shock should be checked and corrected at once. A test lamp can be used to find out which part of the equipment is shorted. Any shock or visible spark indicates that a hot wire is contacting some part of the frame when it should not. If you are unable to locate the trouble, take the faulty equipment to a good electrical repairman.

Overloads: Don't be guilty of “octopus wiring”—too many appliances in one outlet. If fuses blow frequently, you probably need more circuits.

Approved Materials: The Underwriters Laboratory tests electrical equipment to make sure it meets certain requirements for safety. The label, “Underwriters Laboratory,” on any piece of equipment means that it has passed the laboratory tests.

Good Workmanship: Be sure that your wiring complies with the requirements of the National Electrical Code and with local regulations.

Outside Lines: If you see anything wrong with the electrical lines, call your electric power supplier at once. Use care in moving any equipment under or near high voltage lines.

This publication was originally prepared cooperatively by the Agricultural Extension Service of The University of Tennessee and the Agricultural Engineering Development Division of the Tennessee Valley Authority. It has undergone many revisions in the course of 18 printings.

The present major revision was made by Miss LaVerne Farmer, Associate Professor, Home Management and Kenneth E. DeBusk, Associate Professor, Agricultural Engineering, of The University of Tennessee Agricultural Extension Service.

EXTENSION BULLETIN 384

(REPRINT) JUNE 1974

Issued in furtherance of cooperative extension work in agriculture and home economics, acts of May 8 and June 30, 1914, in cooperation with the U.S. Department of Agriculture. Ronald H. Abraham, Director of Agricultural Extension Service, University of Minnesota, St. Paul, Minnesota 55101. We offer our programs and facilities to all people without regard to race, creed, color, sex, or national origin.