

UNIVERSITY
 AGRICULTURE
 OCT 20 1958
 LIBRARY
 INSTITUTE OF AGRICULTURE

Slip Covering

YOUR FURNITURE

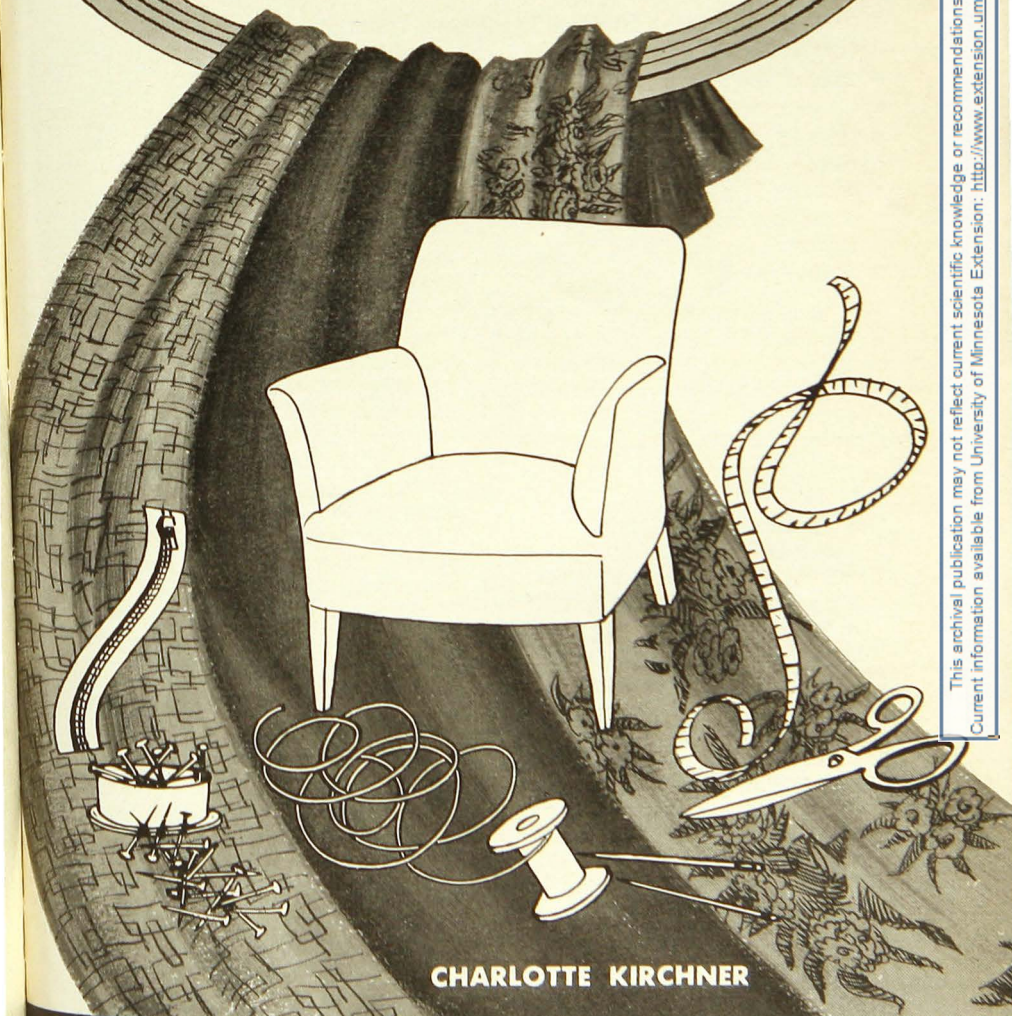

This archival publication may not reflect current scientific knowledge or recommendations. Current information available from University of Minnesota Extension: <http://www.extension.umn.edu/>

CHARLOTTE KIRCHNER

UNIVERSITY OF MINNESOTA
Agricultural Extension Service
 U. S. DEPARTMENT OF AGRICULTURE

Slip Covering

YOUR FURNITURE

Charlotte Kirchner

SLIP COVERS are a definite year-round part of modern room planning. Made of carefully chosen fabric, fitted trimly and tailored smartly, slip covers offer these advantages:

- Protect upholstered furniture from dust and soil.
 - Camouflage poor structural lines.
 - Cover worn upholstery.
 - Fit odd pieces into a room's color plan.
 - Substitute for upholstery sometimes at considerable saving of money.
 - Clean easily.
14. material

The modern homemaker supplied with simple equipment, good material, and enough time and patience can make these slip covers for herself.

To Make a Slip Cover You Will Need:

1. a tape measure
2. a ruler
3. tailor's chalk (blue and white)
4. pins—(heavy pins—half pound box or 5-6 papers)
5. thimble
6. needles
7. sharp shears
8. cording or zipper foot
9. basting thread
10. double duty thread to match slip cover materials—6-8 spools
11. muslin or sacks to fill hollows in upholstery if needed
12. zipper or snaps for closing back, cushion, and anchor under chair
13. welting cord (covered or uncovered) for seams

When you select the material for a slip cover, consider:

1. Is the material itself suitable for slip covering purposes?
2. Will the color and pattern be right in the room?

Excellent selection can be made from either drapery or dress goods counters although drapery fabrics sometimes cut to better advantage. Cotton materials are a good first choice because of their informal character and because they launder well but rayon, wool, nylon, linen, and mixed fiber fabrics also offer wide possibilities. From fabrics you will see you might choose corduroy, crash (cotton, linen, rayon), cretonne, chintz, denim, gabardine (cotton, rayon), gingham, sateen, homespun, monk's cloth, percale, rep, sailcloth, and suiting (cotton, rayon, wool). Good points to check in selecting your fabric include:

Firm and Close Weave

Loose weaves let dust sift through and snag. Loops and long surface yarns (floats) woven in to form patterns are apt to catch and pull on buttons. Materials with much sizing often are limp and sleazy after washing.

Shrinkage Possibility

The words *pre-shrunk* or *shrunk* have little meaning although they may

appear on the bolt. More specific are terms such as:

- Sanforized — (cotton) — claimed to shrink less than 1 percent lengthwise and crosswise
- Perma shrunk—(cotton)—little or no shrinkage
- Tebelized — (rayon) — little or no shrinkage

Look for labels regarding shrinkage. They will be found on selvage, end of bolt, or on a tag attached to the bolt. If there is no shrinkage indication, the material should be shrunk before making up the slip cover.

Finishes That Increase Wearability

Indications of these may be found on bolt or tag and include:

- Crease resistant finishes such as *Superset*, *Brodura*, and *Wrinkl-Shed*
- Water repellent finishes such as *Zelan* and *Aqua-set*
- Crisp finishes such as *Saylerized*, *Bellmanized*, and *Everglaze*

Color Fastness

Yarn dyed materials are woven after yarns are dyed. They do not show changes in color from surface wear.

Printed materials are dyed after weaving and the dyes may not penetrate heavier weights and coarser textures. Color may wear off, giving the appearance of fading.

Look for labels containing *best obtainable vat dyes*, *vat dye*, or *vat color* for assurance of color fastness.

Color Selection

- Slip cover colors must live with those of walls, curtains, floor coverings, and other furniture in a room—be sure they harmonize.

- If more than one slip cover is being used, choose materials in variations of one color rather than in too many unrelated colors.
- Look for clear, rich colors that are new and fresh.
- Clear yellow and red bring light and warmth into a room.
- Consider the use of the chair in selecting the color. A lounge chair for a man's corner will hold little appeal for him if you dress it in a pink sateen cover.

Good Design

- Select plain or textured fabrics where there is much design in the rug or wallpaper of the room.
- One pattern for both draperies and slip covers is better than two or more different designs.
- Large floral patterns are difficult to work with. They must be centered and require more yardage.
- Broken and irregular plaids and stripes of unequal width and color value are easier to look at than bold, regular types. There is usually a right and left interest in spacing of stripes that should be followed in using the material. Plaids should have either a dominant horizontal or vertical line to prevent confusion. Stripes and plaids make good design accents.
- Small, all-over, geometrical patterns, gay in color and easy to look at are good selections and simple to work with.
- Modern designs have uncrowded and less detailed patterns. Colors are clear and rich and fewer colors are used in one design than in other style materials. Modern designs can fit into most rooms.

Note: Select plain or small woven design if this is your first slip cover. It will be easier to work with.

Measure Before You Buy

Back length—Chair frame to top A-B plus 2-inch seam allowance.

Front back length—B-C plus 2-inch seam allowance plus 4-inch tuck-in allowance.

Seat length—C-D plus 2-inch seam allowance plus 4-inch tuck-in allowance.

Apron—seat edge to chair frame D-E plus 2-inch seam allowance.

Outside arm length—F-G plus 2-inch seam allowance (double).

Inside arm length—F-H plus 2-inch seam allowance plus 4-inch tuck-in allowance (double).

Cushion length—I-J plus 2-inch seam allowance (double).

Cushion depth—J-K plus 2-inch seam allowance times distance around cushion divided by width of material.

Flounce—L-M plus 2-inch seam allowance times distance around chair divided by width of material.

Width of chair—N-O plus 2-inch seam allowance will indicate width of material needed.

Total divided by 36 inches (one yard) equals yards needed.

Note: If large floral pattern needing to be centered is used, add $1\frac{1}{2}$ to 2 yards to above.

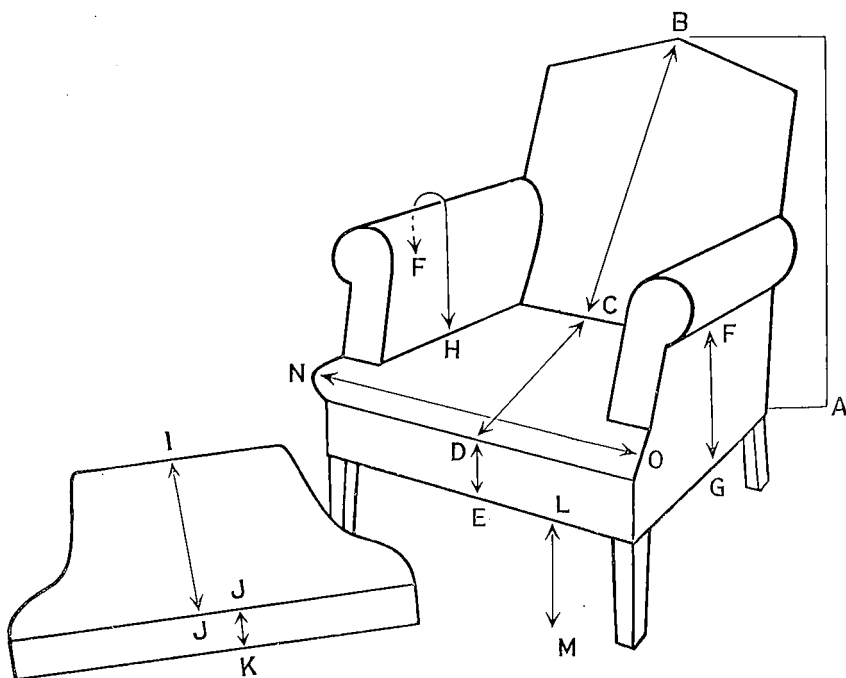

The following table shows the approximate yardage of material and welting needed for various types of chairs and couches. If you are making your own welting, add the yardage in column 3 or 4 to the goods yardage shown in column 1 or 2. While the

yardages shown will provide a guide for those who do not wish to measure, it is better to actually measure the furniture to be covered since there are variations in construction of different pieces.

Type	Goods yardage (yards)		Allowance for welting (yards)		Welting cord (yards)	Stock welting or fringe (yards)
	36"	50"	36"	50"		
Lounge chair } Barrel chair } Wing chair }	11	9	1½	¾	18	18
Club chair	10	8	1½	¾	18	18
Cogswell chair	10	7½	1½	¾	20	20
Boudoir chair	6½	5	1½	¾	11	11
Davenport (3 cushions)	20	15	3	2	36	36
Studio couch (3 cushions)	15	12	2	1½	30	30
Studio couch (extra mattress)	21	16	3	2	40	40

Be Sure Your Chair Is Ready

Old Furniture

- Patch torn places.
- Fill hollows in back or on arms by applying layers of muslin until

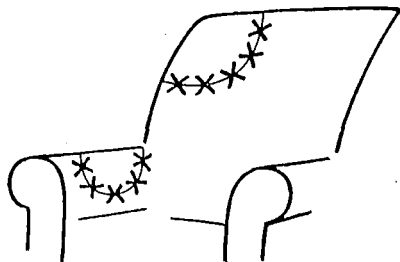

surface is filled out and smooth. Catch stitch these layers to upholstery.

If Chair Is Leather Covered

- Fit muslin to surfaces of chair. Old sheets may be used.
- Using an upholsterer's half round needle sew muslin through the upholstering material to keep slip cover from slipping on chair surface.

Chairs with Wooden Frames

- Be sure chair is sturdy. Replace rounds and brace back with angle irons if necessary.
- Pad frame with upholsterer's cotton.
- Cover frame and cotton with muslin.
- Sew in place.

Note: Old comforters can be used to pad frames. Foam rubber can be used to cover chairs before slip covering.

Fit Your Slip Cover Step by Step

Step I

Pin welting to, or mark with tailor's chalk, the exact line at the outside top of chair that you will want in your finished slip cover. Make a similar line around the entire bottom of the chair at the depth the founce should start.

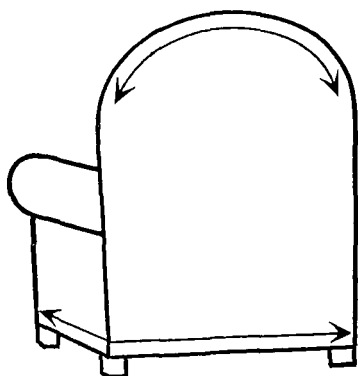

Indicating these two lines will adjust the slip cover to correct poor structural lines if they are present.

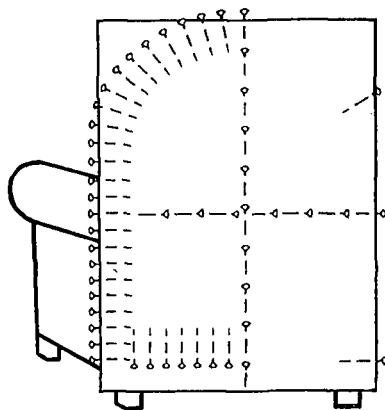

2. Place a row of pins down center back and across center back to prevent slipping.
3. Continue pinning around the entire outside edge of chair. Have the material fit snugly but do not stretch.
4. Trim to seam depth on all sides.
5. Mark exact seam line with tailor's chalk.

Step II

Cut a length of material to reach from the outside top of the back to the indicated line at the lower frame of the chair plus a 2-inch seam allowance. Using right side out, center the material at the top and lower edges, making sure it is on the grain. If a large pattern is used, this should be centered crosswise and a little closer to the top line than to the lower chair edge. An additional amount will have to be allowed for this placing before the back length is cut.

1. Pin at top center, bottom center, each side center, and at each of the four corners.

Step III

Cut a length of material long enough to fit from the inside top of the back of chair to the seat line plus 6-inch allowance for seams and tuck-in. Center this the same as you did on the back of the chair.

1. Pin at center top and at center bottom line making sure material is on the grain.
2. Pin at upper outside corners and at side directly above the joining of arm to back.
3. Place a row of pins down center front and across center front to keep material from slipping.

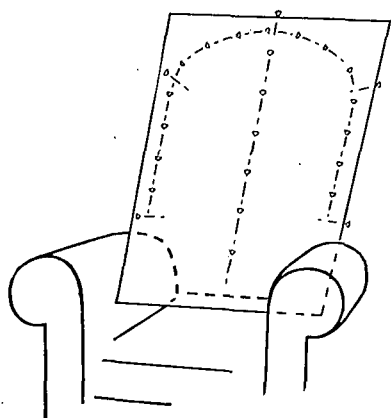

4. Holding the seam allowance of the back and front pieces together, pin on the seam line across the top and down the two sides to the point where the arms join the back.
5. Lay any fullness at corners of top in small pleats on the grain of the material.
6. Trim edges to 1-inch seam depth.
7. Using the back of your shears push the tuck-in allowance into the seat and back joining as smoothly as possible and into the curve of arm and back joining.
8. At right angles to the fullest part of the arm on top, slash from the

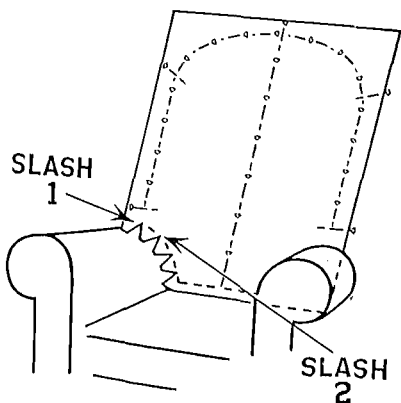

edge of the material to the joining curve.

9. Make a second slash at right angles to the fullest part of the arm inside.
10. Slash at half-inch intervals around the remaining parts of curve until material lies smoothly at joining.
11. Mark seam line with tailor's chalk from outside arm roll to seat.
12. Trim edges to 1-inch seam depth.

Caution: Slash carefully and to only the depth necessary to make material lie smoothly. Too deep a slash will weaken seam joining.

Step IV

Measure distance from outside edge of arm roll to seat edge. Add 6 inches for seam and tuck-in allowance. If

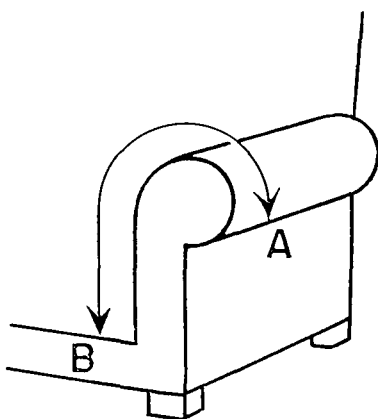

large pattern material is used, place on inside arm to center before cutting. Cut two pieces the same size and the same pattern centering.

1. Center pattern on inside arm allowing it to extend over roll on outside arm, and allowing 1 inch for seam under roll.
2. Place a row of pins down center of inside arm to prevent material slipping.

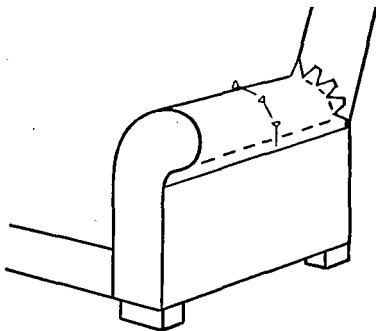

3. Smooth over inside arm and with scissors push down tuck-in at seat line as far as possible.
4. Pin at seam line under arm roll.
5. Fold back fitted inside top back covering and fit inside arm covering around arm curve in same manner as described in Step III.
6. Mark seam line with tailor's chalk from outside arm roll to seat.
7. Trim edges to 1-inch seam depth.
8. Starting at top of arm roll, pull and pin surplus material into front arm curve in a series of small pleats laid on grain of goods.
9. Trim to 1-inch seam.
10. Fit second arm in same manner.

Step V

Measure the distance from the under side of outside arm roll to the indicated line at the lower frame of the chair. Add 2 inches for seams. Center pattern as indicated in step IV if necessary. Cut two pieces of this size and centering.

1. Center pattern of one of these pieces on outside of chair arm making sure material is on the grain.
2. Pin at both upper corners and both lower corners.
3. Place a row of pins down center of chair side to keep material from slipping.

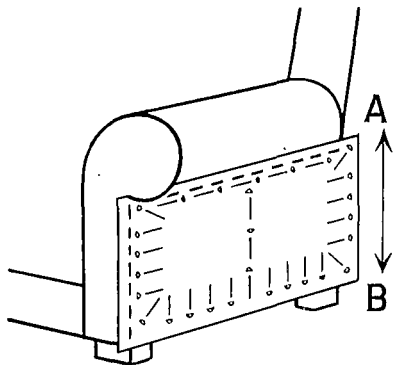

4. Holding the seam allowance of the inside arm and the outside arm together pin on the seam line across side under the outside arm roll.
5. Continue pinning around the front side chair frame and across bottom.
6. Holding the seam allowance of the outside back cover and the side arm cover, pin on the seam line at back edge of chair side.
7. Repeat with other arm.

Step VI

Measure length of chair seat A-B. Add 6 inches for seams and tuck-in. Measure width of chair seat at widest

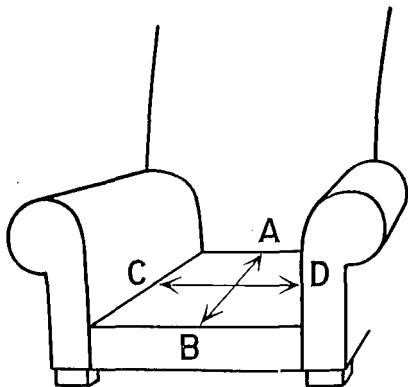

part and add 10 inches for seams and tuck-in. Cut one piece of material to fit these two measurements cutting the line A-B on the lengthwise of the goods.

1. Center material on chair seat making sure it is on the grain.
2. Place a row of pins down center length of chair seat to keep material from slipping.
3. Place a row of pins across center width of chair seat.
4. Using back of shears force tuck-in into crevices on back and side of chair. Side crevices will taper out toward front edge of chair.

Step VII

Measure distance from edge of chair seat to indicated line at lower chair

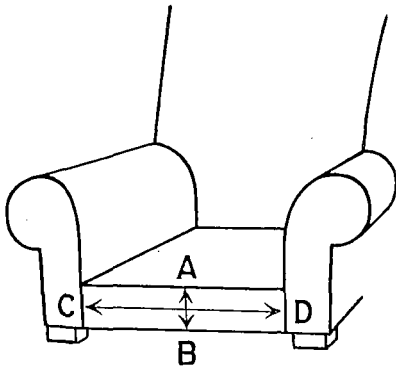

edge, A-B. Add 2 inches for seams. Cut a strip crosswise of the material the width of front chair edge C-D plus 2 inches for seams. This strip should be cut so that in patterned fabric the pattern will look best with the **inside top back** of the slip cover.

1. Anchor this strip to chair apron at its top and bottom corners.
2. Holding the seam allowance of the chair seat and the top of the apron together pin **on** the seam line.
3. Pin along the lower chair edge.

Step VIII

Mark all seam allowances except at tuck-in around the chair seat as follows:

1. Where pins are following seam line place a chalk line at right angles across each pin on **each side** of seam.
2. Where pins are placed at right angles to chair edge to fit cover to **outline of chair**, place a chalk line at right angles to pins and along outline of chair.

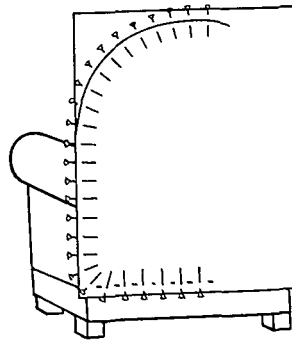
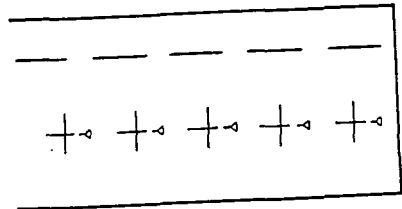

Step IX

1. Remove all pins except those holding pleats at front of chair arms.
2. Insert welting at seam lines (a) around chair back basting it first to the outside back, (b) basting on inside back at curve where inside arm joins inside back.
3. Baste all seams including those allowed on tuck-ins except left outside back from point of curve to lower chair line. This is fitted

with a zipper to allow for slip cover's removal.

Step X

Replace cover on chair and check for fit. Leave in place until front armpiece is fitted.

Step XI

Using a piece of scrap material fit around front armpiece as shown in illustration.

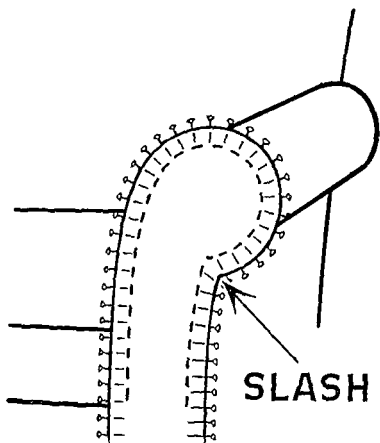

1. Mark seam line as indicated in step VIII. Remove from chair and cut two pieces of slip cover material like pattern laying the long

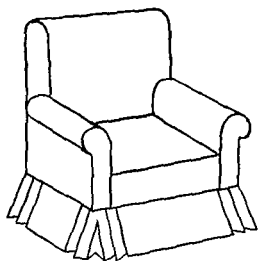

Group pleated flounce.

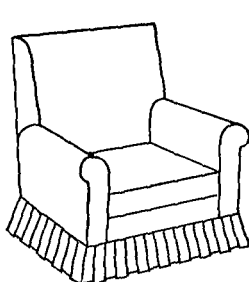

Box pleated flounce.

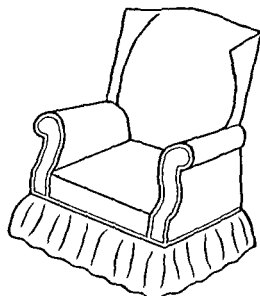

Gathered flounce.

way of the pattern on the lengthwise of the goods.

2. Baste welting completely around armpiece except across the bottom edge.

Step XII

Remove slip cover from chair and stitch all seams.

Step XIII

Baste front armpiece to slip cover and stitch just inside welting.

Step XIV

Baste welting around bottom edge of slip cover starting and ending at open seam on left back.

Step XV

Measure distance from adjusted lower chair edge line to floor. Add 3 inches for seams and hems. Cut as many pieces crosswise of the material as will total (if gathered) 2 times the distance around the lower chair edge; (if pleated) $2\frac{1}{2}$ times this distance.

1. Sew these strips together.
2. Make a $1\frac{1}{2}$ inch hem with a $\frac{1}{2}$ inch turn under along one entire edge. Slip stitch hem down.

3. Gather or pleat to lower edge of slip cover. Pleating instructions will be found on page 16.

Step XVI

Insert a zipper in left back seam—long enough to reach from point of curve to 1 inch from bottom of flounce. Zipper instructions will be found on page 15.

Step XVII

Turn the chair on side.

1. Use cambric or muslin for underneath anchor.

2. Measure A-B and C-D and allow 2 inches for seams.

3. Pin at center front, center back and each side, keeping on grain of goods.

4. Continue pinning around chair.

5. Cut out at each corner at leg line.

6. Reinforce each leg cutout.

7. Attach open-end zippers of the proper length to the front, back, and both sides. Or sew the anchor to the slip cover at the flounce seam on the front and use zippers at the back and sides.

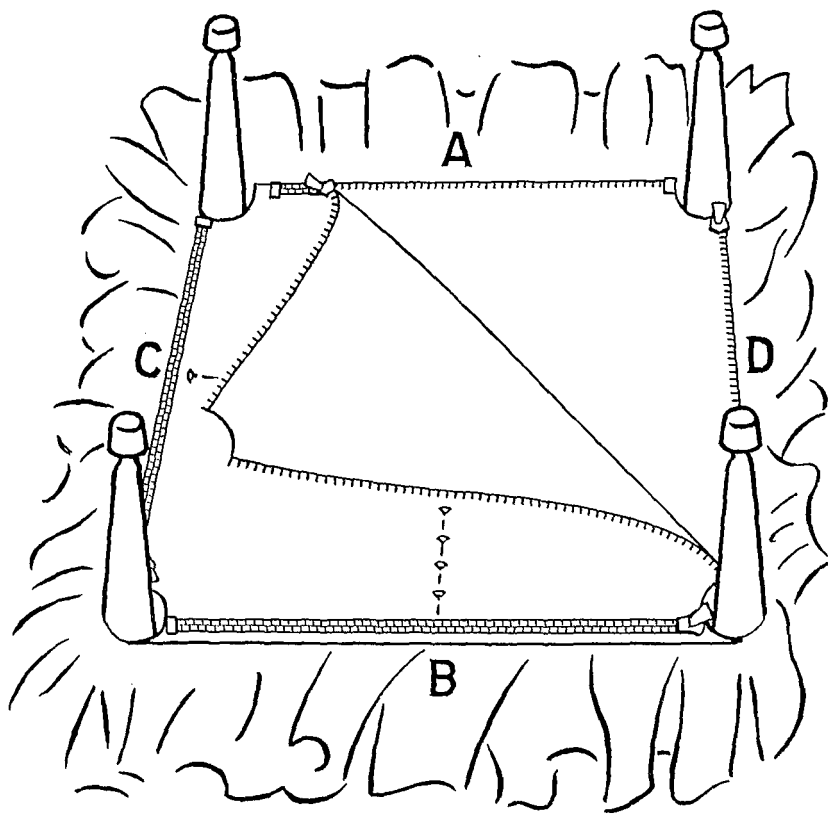

Step XVIII

Lay chair cushion on paper and trace a pattern. Center this pattern on material making sure both lengthwise and crosswise threads are straight. Cut two pieces allowing 1 inch all around for seams. Measure the distance across the back of the cushion and 5 inches down each side A-B. Add 2 inches for seams. Measure depth of boxing C-D. Cut two pieces this length and one half the width of boxing plus 2 inches for seams.

Measure remainder of distance around cushion E-F, and add 2 inches for

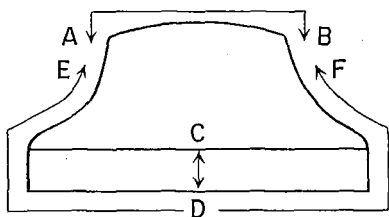

seams. Cut one piece this length and the width of boxing plus 2 inches for seams.

1. Fold 1-inch seam to wrong side on one edge of each piece of half width boxing.
2. Pin folded edges over a zipper long enough to come to within 1 inch of each end of strip. Have one fold overlap the other slightly.
3. Stitch each side of zipper $\frac{1}{2}$ inch back of fold.
4. Join the zippered strip to the rest of boxing at each end.
5. Baste welting to the right side of each of the top and bottom section of cushion cover.
6. Baste boxing in place on top and bottom of cushion cover making sure corners are turned smoothly.
7. Stitch and clip seams at corners. Turn cushion cover to right side.

If Your Chair Is Different In Shape

The steps above will still apply. Some variations include:

The Wing Chair

- Fit the inside wing matching design if any to inside back.
- Lay fullness in small pleats at top of wing.
- Pin around outside edge of wing from top to arm joining.
- With back of shears push material into tuck-in. The tuck-in will taper off at top of wing.
- Fit outside wing matching design if any and as far as possible to outside arm.
- Holding the seam allowance of the inside wing and the outside wing

together pin on the seam line around the outside edge. Trim to 1-inch seam.

- Holding the seam allowance of the outside back of the chair and the outside wing together pin on the seam line to where arm joins chair.
- Trim to 1-inch seam.
- Proceed as outlined in general instructions.

The Cogswell Chair

- Fit outside back.
- Fit inside back.
- Where the arm meets the inside back of the chair slash the inside

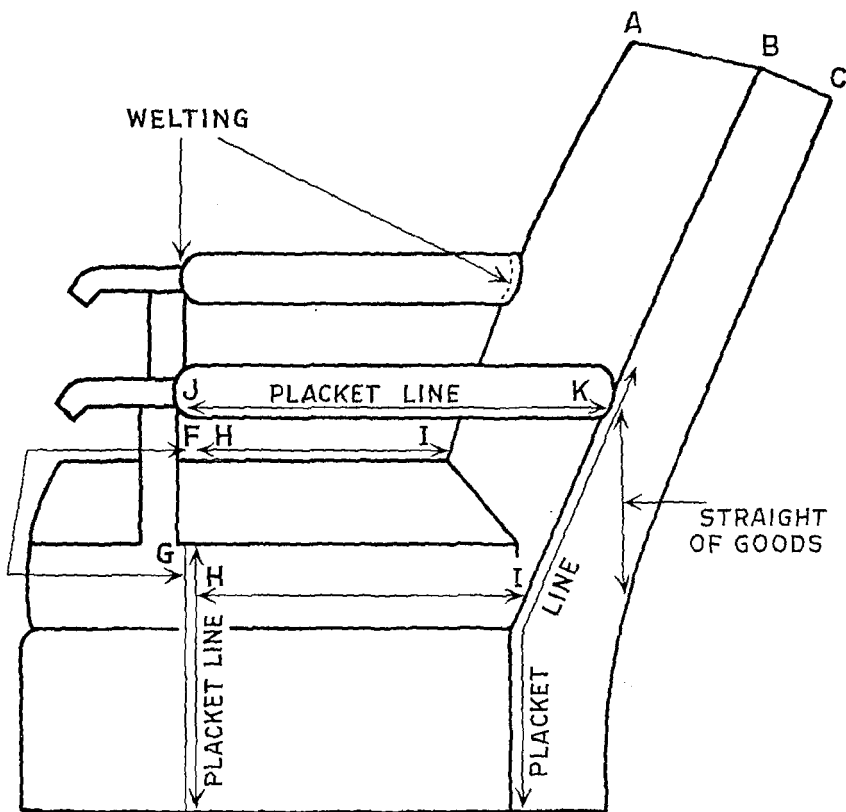

back covering to fit the form of the arm. Baste welting around this opening.

- Cut a band across the top of the chair back A-B, on the crosswise of the material.
- Fit bands down the side of the chair back BC-DE. Material should be on the lengthwise and kept on the grain—not slanted.
- Apron bands and flounce are cut in three sections.
 1. FG from behind armpost on one side to similar point on opposite side.
 - 2,3. HI from behind armpost to front edge of side panel.

- Zippers close openings at indicated placket lines.
- For arm covering lay material on arm lengthwise of goods. Fit smoothly over top. Allow 2 inches on underside for placket closing.
- Pin darts at front to fit covering around arm. Finish this edge with welting.
- Fit arm covering into inside back opening where it has been cut out to fit arm. Stitch.
- Insert zipper at under side of arm.

Note: Other fitting and construction steps are the same as those given in general instructions.

The Channel Back Chair

The channels on a channel back chair can be filled with upholsterer's cotton and covered with muslin before a slip cover is fitted. This will eliminate the channels as a problem. If this is done, slash the bottom of the inside back covering from its lower edge to the chair seat line and set in gores so that bottom edge will match the tuck-in of the chair seat in width. If channels are to be emphasized—

- Lay and pin darts at top of each channel as inside back is being fitted.
- Push material into recess of channel.

- Fit outside edge of inside chair back.
- Mark darts, channel lines, and outside edge of inside chair back with tailor's chalk.
- Remove from chair.
- Top stitch darts at top of inside back to a depth of 3-4 inches.
- Stitch darts at the tuck-in to match width of tuck-in of chair seat.
- Replace on chair and continue fitting of slip cover.

Davenport and studio couches are usually variations of chairs on a larger scale. General instructions for slip cover construction can be followed.

How to Do . . .

Your Own Welting

- Cut a square of slip cover material. This may be a yard square in size if much welting is to be used or small pieces of slip cover material may be used up in constructing welting.
- Fold the square in half on the bias. Place a row of pins along this bias fold. Cut on the line marked by the pins.

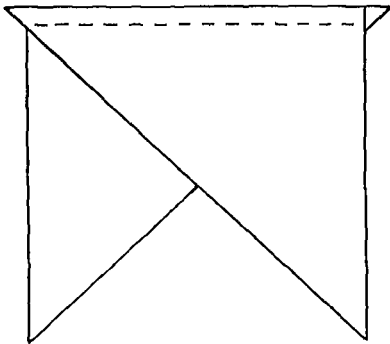

- Place the two edges running on the lengthwise thread together. Stitch a $\frac{1}{2}$ -inch seam. Press open.
- Lay the stitched length of material flat on a table. Using a yard stick mark off the width of bias needed to cover welting (1 $\frac{1}{2}$ -inch width will cover $\frac{3}{4}$ -inch welting and leave adequate seam allowance).

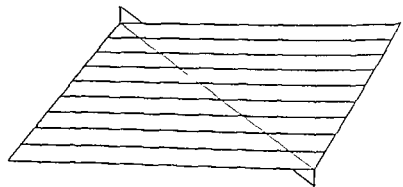

- Place the two crosswise edges of the strip together to form the strip into a tube. Slip one edge along the other until the bias edge meets the first marked line. This will allow the extension of one row of bias at each end beyond the stitching. Pin the crosswise edges together at the marked lines.

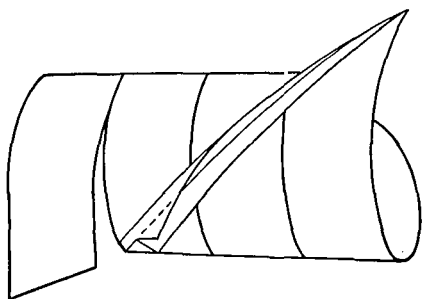

- ① Stitch crosswise edges with a ½-inch seam. Press seam flat.
- ② Cut around the resulting tube on the marked lines.

Note: This will result in one continuous strip of bias with the sewing of only two seams. One yard of material 36 inches wide should make approximately 24 yards of 1½-inch bias stripping.

- ③ Fold bias stripping over cord and using cording foot stitch as closely as possible to cord.
- ④ Where necessary to join welting (as around edge of cushion) measure exact length needed. Add 1 inch for joining. Baste welting to cushion top. At joining:
 1. Rip bias open for 3 to 4 inches.
 2. Cut cord until ends just meet.
 3. Seam together the ends of the bias to cover the cord joining.
 4. Cover cord and baste to cushion top.

Note: Follow the same procedure for the other side of the cushion top and for any other areas where welting must appear as a continuous line.

A Zipper Closing

- Select open end zippers of a length that will fit the various closings necessary to slip cover. Approximate lengths include:

back	27 inches
under seat anchor	18 inches

side arm (Cogswell chair)	12 inches
under arm (Cogswell chair)	14 inches

- Fold under seam allowance on one side of closing. Baste to closed zipper as near closing line as possible. Have open end of zipper come to within 1 inch of bottom edge of flounce.
- If welted edge is used, baste this edge to slightly overlap the other side. If welting is not used turn under seam edge 1 inch and place on zipper overlapping the folded edges slightly.

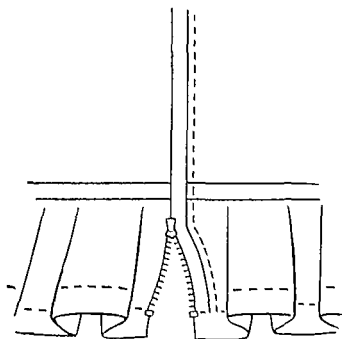
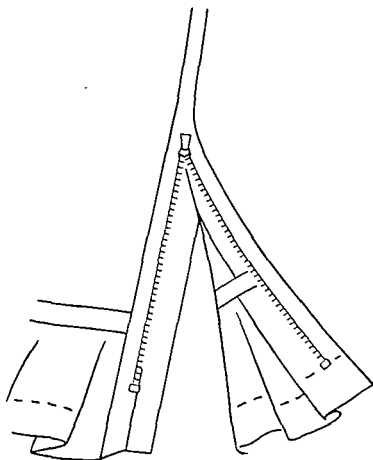

- Top stitch under side as close to zipper as possible.
- Stitch welted edge as close to cording as possible. If a second folded edge is used instead of welting, stitch this edge $\frac{1}{4}$ - $\frac{1}{2}$ inch back of zipper line.
- Under arm and under seat anchor zippers can have the same allowance turned under and top stitched the same on both sides of zipper.

Note: A cording foot makes putting in a zipper a simple process.

Box Pleating for a Flounce

- Lay hemmed flounce on table.
- Measure with ruler and mark with tailor's chalk 3 inches from one end of strip and then $2\frac{1}{2}$ inches thereafter.

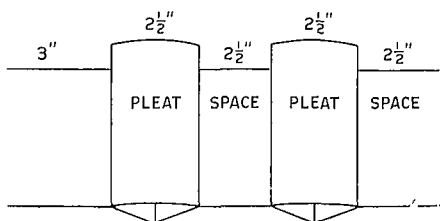
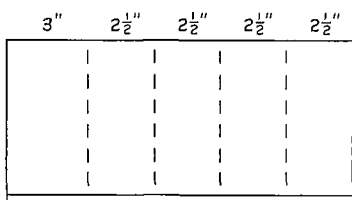

Important: Do not let seam come on top of pleating but adjust until it is hidden and then continue as above. Lay pleats straight with the threads of material.

- Slip the completed flounce under the welted lower edge of slip cover and baste.
- Stitch as close to cording as possible.

If welting is not used on lower edge of slip cover body, the flounce may be joined to it with a heading or with a top stitched seam.

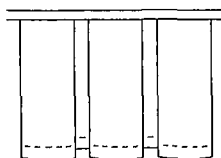

Flounce pinned with welted seam.

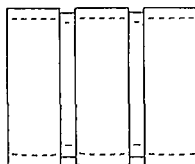

Flounce with heading.

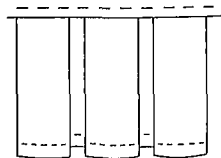

Flounce with top-stitched seam.

UNIVERSITY OF MINNESOTA, INSTITUTE OF AGRICULTURE, ST PAUL 1, MINNESOTA

Cooperative Extension Work in Agriculture and Home Economics, University of Minnesota, Agricultural Extension Service and United States Department of Agriculture cooperating, Skuli Rutford, Director. Published in furtherance of Agricultural Extension Acts of May 8, and June 30, 1914.

10M-7-53