

# REUPHOLSTERING at Home

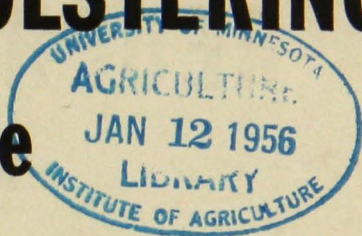

by Helen H. Matheis



This archival publication may not reflect current scientific knowledge or recommendations.  
Current information available from University of Minnesota Extension: <http://www.extension.umn.edu>.

# REUPHOLSTERING

## at Home

Helen H. Matheis

**I**F SAGGING SPRINGS and bumpy padding in your chairs and davenportes are spoiling the comfort and good looks of these pieces, you can reupholster them at home and make them more comfortable, durable, and attractive.

Even if you have never tackled upholstery before, you will find you can do a craftsman-like job if you use the right tools and materials and devote the time and patience which this work requires. Reupholstering is all hand work. You will have to replace the upholsterer's skill with your own but you can do this—and save money.

### Preparations

All uneven padding, sagging springs, and worn webbing should be removed. The entire frame should be reglued or braced where necessary. Remember, too, any piece of furniture worth reupholstering should be of good lines, strong wood, and solid construction.

### REMOVE OLD UPHOLSTERY

To remove old upholstery, you need a tack puller, screw driver, tack hammer, chisel, pliers, tape measure, and note pad and pencil.

Place furniture on two sawhorses or four orange crates to bring your work to a convenient height. Assemble tools and materials on a nearby table. Keep tacks in labeled glass jars and in a pie tin while working. Your furniture will not slip off the sawhorses or orange crates if you attach a narrow strip of wood, padded with burlap, to the outer edge of the base supports.

Remove braid or gimp, outer covering, and tacks. Make note of the length of the tacks and places used. Remove outside back cover first, then in order—front arm piece, outside arm piece, inside arm piece, front seat sections, seat cover, and inside back.

Remove padding, separating cotton from hair or moss and tow. Padding in good condition can be reused. To clean hair padding, draw it through steaming hot water and pin on line to dry. Re-fluff moss and tow with an ice pick.

Brush out the frame and make sure to remove all tacks from it. If the frame is weak and worn with tack holes, re-inforce it with strips of new wood fastened to the inside edge of the frame.

Inspect springs and webbing. If springs stand fairly straight and you can look straight down into the center of them, they can be used again. Note how they were sewed and tied.

Sometimes only one or two springs need retying. If so, cut twine only where necessary to retie. Usually, all

old tying twine, springs, and webbing are removed and new webbing and twine used and springs replaced as necessary.

## REPAIR AND REFINISH BEFORE REUPHOLSTERING

If parts of the frame are cracked, and the rails or joints are loose, you will have to reglue them. Use a liquid glue especially made for cementing wood, a liquid hide glue, a powdered casein glue, or sheet glue, and follow directions on the glue container.

Glue sticks to wood better than to hardened glue so carefully chip off all the old glue. If you insert a joint in a section where it has been impossible to remove all the old glue, pad it with a strip of cloth cut to extend half-way over the part to be inserted. Apply glue lightly with a brush and force pieces in place by clamping under pressure 24 hours. Use steel braces and metal clamps or a strong clothes line, made firm with tourniquets. Place pads of paper where rope touches frame.

Be sure to wipe off all excess glue while it is soft.

Weak corners of a frame should be braced with a triangular corner block, screwed in place.

Deep holes or cracks in a frame can be filled with shellac gum in a color to match the wood. Brace the frame firmly to dry.

You can often reshape the old framework. This isn't difficult, because ornamental curves are usually glued on and can be removed easily with a chisel. To change curved arm and back frames to straight lines, you need a pencil, yardstick, and saw. Refinish any part of wood which will show after reupholstering.

## TOOLS AND MATERIALS

**Webbing:** Four-ply jute webbing. If steel webbing has been installed, note

its width ( $\frac{5}{8}$  or  $\frac{7}{8}$  inch) for replacement.

**Webbing stretcher:** May be bought or made at home. To make one, use a piece of hardwood  $\frac{3}{4}$  inch thick, 4 inches wide, and  $7\frac{1}{2}$  inches long. Drive eight penny-nails into one end of the block so that they protrude 1 inch. Cut off heads of the nails and file the ends to make sharp-pointed teeth about  $\frac{3}{4}$  inch long. Cover the other end of the stretcher with felt, leather, or stair-tread material to prevent it from slipping and marring the finished wood. If the sides of the block are curved, it is easier to grasp.

**Tacks:** Upholsterer's tacks split the wood less than carpet tacks. Size and quantity vary with the piece being upholstered. Measure the shank length and use as a guide for ordering new tacks. Wire webbing tacks and No. 3 (small), No. 8 (medium), and No. 12 (large) are usually used. Gimp tacks are needed for the outside edge finish if gimp trim is used there.

**Hammer:** Upholsterer's hammer or one with a face about  $\frac{1}{2}$  inch in diameter.

**Springs:** If any of your springs need to be replaced, order them according to location in the frame. For example, seat springs, cushion and back springs, springs on strips as seat bars and back bars, No-Sag springs, and platform rocker springs. State in your order whether the seat springs have narrow or wide centers, and also list the height. Cushion and back springs are double knotted and can be had in lengths of 4, 5, 6, or 8 inches. To replace spring strips or bars, order according to length of bar (seat bars are  $19\frac{1}{2}$ , 23, 25, and  $27\frac{1}{2}$  inches long with 3 springs to each bar; back bars come in 20-, 22-, and 24-inch lengths, 3 springs to a bar).

If No-Sag springs span the seat and back frame and you need to repair a length of these springs within the frame, measure the length needed and include in your order No-Sag nails and

the No-Sag clips which are needed to attach the spring spans to the frame.

Platform rocker springs are quickly installed with screws for each spring. No. 8½ is used for medium-size chairs and No. 9 for large club chairs.

If you need to replace springs in an innerspring cushion, measure the diameter of the spring taken from its muslin or burlap pocket. Most of these small springs are 3½ inches high and 2½ or 3 inches in diameter.

**Steel spring edge wire:** Comes in 12-foot lengths. Use it as a binding edge on spring cushions and box springs.

**Twine:** Six-ply hemp twine to tie springs and Elm flax mattress twine to sew springs and padding.

**Needles:** Use curved upholstery needles: size 2½ or 3, to sew outside cover; size 4 to sew burlap to springs; and size 6 to 7 to sew moss to burlap base.

Use a double-pointed, straight upholstery needle in 6- or 8-inch length to sew springs to burlap and to make edge rolls. Or substitute a coarse darning needle for this work.

A mattress needle, 8 inches long, is needed to stitch through double padding.

**Padding:** Fine tow (a flax fiber), picked tree moss, and cotton felt (upholsterer's cotton) are conventional types of padding used from the burlap covering the springs to the outer fabric. Curled hair or medium-grade rubberized curled hair, sold in sheets, when substituted for moss, add resilience and long life to padding. Seat, back, and arm measurements of each piece indicate the amounts of moss and cotton needed. Usually, 12 to 15 pounds of moss cover a two-piece suite. Cotton felt weighs 16 ounces a yard. About 10 pounds will cover a chair and 22 to 25 pounds, a davenport.

**Spring and roll edging:** Can be ordered ready-made for protection of spring edges and all hard edges of frame. This is jute-filled and paper-

filled edging in ¾-inch and 1¼-inch diameters.

**Burlap:** To cover springs and make first cover over the padding. Comes 40 inches wide. The 10- or 12-ounce quality is recommended.

**Blind tack strips:** These are cardboard strips used to make straight edges for invisible tacking of the outside cover. They are ½ inch wide and 38 inches long.

**Denim:** To cover platform of chair or davenport with separate cushions.

**Unbleached heavyweight muslin:** 36 inches wide. Used to cover the padding and hold it in place. For yardage, see following paragraphs and estimate same as outside covering fabric.

**Fabric for outside cover and thread:** Amount needed depends on measurements of furniture, whether it has separate seat and back cushions, and on your selection of plain or patterned material. Most upholstery fabrics are 54 inches wide.

To figure yardage, take length and width measurements for each section to be covered, measuring between tacking points on frame edges. Allow 2 inches on all these edges to handle material effectively.

Measure fabric for the inside back of a chair, the seat, the inside arms, the outside arms, and outside back. Some chairs require one or more strips for insets along the arm, back, cushion, and across the front below the seat. If you plan to make cording from upholstery material, allow ½ to ¾ yard for a chair and 2 yards for a davenport. Cushions usually require 1½ yards.

#### Upholstery Yardage (approximate)

|  | Yards of<br>54-inch<br>fabric |
|--|-------------------------------|
| Sofa: three cushions .....                     | 10                            |
| One arm chair: one cushion .....               | 5                             |
| One arm chair: no cushion .....                | 4½                            |
| Barrel chair .....                             | 6                             |
| Cogswell chair: one cushion .....              | 5                             |
| Cogswell chair: no cushion .....               | 4                             |
| Pull-up chair: no springs, seat and back ..... | 2                             |

|   |    |
|---|----|
| Pull-up chair: spring seat, seat only .....               | 1  |
| High-back chair: spring seat, padded back .....           | 2  |
| Ottoman: cushion type .....                               | 1½ |
| Ottoman: no cushion .....                                 | ¾  |
| Extra cushion: spring filled or padded .....              | 1½ |
| Six dining room chairs: slip seat on plywood .....        | 1¾ |
| Six dining room chairs: webbed bottom on seats only ..... | 1¾ |

If the cover is finished with a flounce, the inverted pleats at the corners require extra yardage.

For a chair add one yard for regular size pleats (depth of three inches) and 1¾ yards for high platform kick pleats.

For a davenport add 1½ yards for regular size pleats or 2½ yards for high platform kick pleats.

**Black cambric:** To cover base of webbed or spring seat section of furniture (usually 1 yard for a chair).

**Cotton welt cord:** Needed to reinforce the boxed edges of cushions and to finish the bottom edge of seat, arm, and back pieces in all fine upholstery.

**Upholsterer's pins:** In 3 and 3½ inch lengths, are helpful to fasten covers temporarily in place while being fitted.

## Procedure

### MEASURE AND ESTIMATE WEBBING

You will need webbing to cover the openings within the chair frame including seat, back, and arm sections. To estimate number of strips needed for a firm foundation, measure seat frame from back to front edge. Measure back frame from top of frame to seat rail. Arm sections are webbed on the inside so measure from the top arm frame to the under-arm rail support. None of the strips should be more than 2 inches

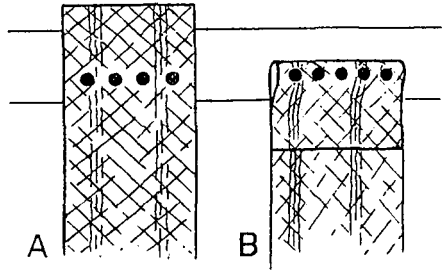

Fig. 1. Fastening webbing.

apart. Allow 3 inches on each strip for a hem turn-back.

### Fasten Webbing

Web the seat section first, then the back, and finally the arm area. Place webbing across underside of seat frame and tack strips from back to front and from side to side of seat frame. Web the inside back from top of back frame to seat rail. If back springs are used, place webbing on outside back of the frame; otherwise, web on the inside edge of this frame. Fasten arm webbing on the inside arm section, tacking strips from the inside edge of the top arm frame to the under-arm rail support.

To tack webbing in place, fold the 3-inch hem allowance and tack it to the frame along the folded line with four No. 8 tacks. Bring cut edge of the strip over and tack down again, using five tacks, as in figure 1. Always tack on the inner half of the frame to allow space for rows of cover tacks.

Stretch webbing tight, using a webbing stretcher as leveler (figure 2).

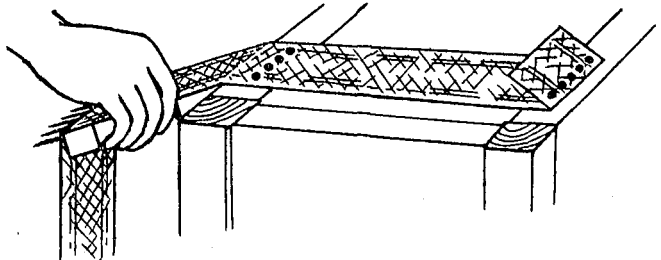

Fig. 2. Stretching webbing.

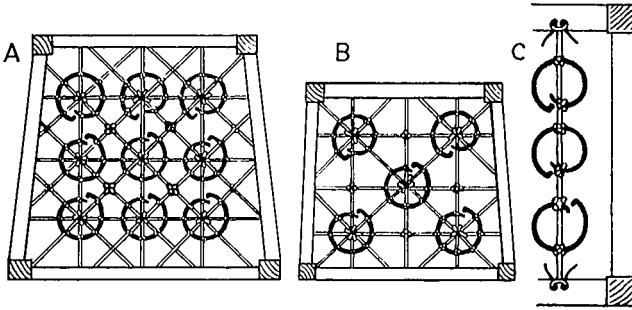

Fig. 3. A, B. Seat springs tied, bottom view. C. Seat springs tied on top of frame.

Tack to frame, fastening in place as you did before.

Continue fastening webbing across seat section and across back and arm pieces. Interweave webbing in each direction to make a firm foundation. The closer the webbing, the stronger and more durable will be the foundation. For average chair seats, interweave three strips of webbing in each direction, one on each side of the center strip, dividing the space equally.

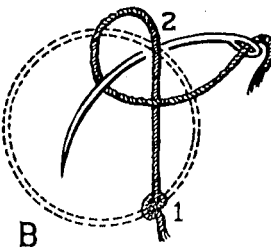
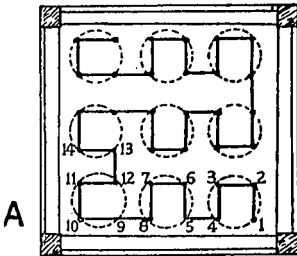

Fig. 4. A. Stitching burlap to springs. B. Detail of slip knot.

### PLACE THE SPRINGS

The average chair has five or nine springs, placed as in figure 3, A and B.

Place each spring at the crossing of the webbing strips, so that the center of the spring is directly in line with the twine as it is tied from back to front. Be careful to turn the spring so that the end which points downward is on top and just to one side of where the twine is to be tied.

Pencil a mark on the webbing around each spring. Pencil line shows exact position of spring and saves time in replacing it for sewing.

### Sew Springs to Webbing

Sew springs to webbing as marked (figure 4A). Use two threads of mattress twine. Be sure springs are in place, with bottom of spring (flat side) on webbing. Use an upholsterer's straight needle and long thread.

Start needle from underneath webbing. Work up and over the lower wire of the spring and down again close to the wire. Tie a slip knot (figure 4B) on first and last stitches on each spring by passing needle under a loop.

Take three more stitches at equal distances apart on the spring. Sew tightly and firmly so there is no play in the spring. Plan to have the last stitch on a spring near the next spring to be sewed (figure 4A).

Cross to next spring without cutting twine and repeat until all springs are sewed to webbing.

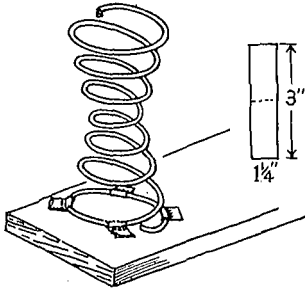

Fig. 5. Fastening springs to wood slat. Leave one to two inches space between spring and chair frame so that springs will not rub against frame when pressed down.

### Fasten Springs

**On Slats:** To fasten springs on wood slats use four pieces of webbing, each about  $1\frac{1}{4}$  inches wide by 3 inches long. Fold each strip in half, crosswise, then place the folded line over the bottom ring of the spring. Tack with three or four No. 8 tacks close to the wire (figure 5).

Instead of webbing and tacks, staples may be used to fasten springs. To prevent the staple and spring from rattling against the wood, put pads of webbing underneath the bottom loose spring wire.

**To Spring-Edged Wire:** Often a wire edge is used between the springs on the front and side edges of chairs, couches, and sofas to box them in and give strength. Fasten the edge wire to the edge springs before the springs are tied. Use a double length of stitching twine 15 inches long. With the double end of twine, loop one of the outside springs to the wire, pulling ends through (figure 6A). Then wind cord over the wire and spring about seven or eight times (about  $\frac{3}{4}$  inch). Bring cord up between wires at No. 1 and cross over to No. 2

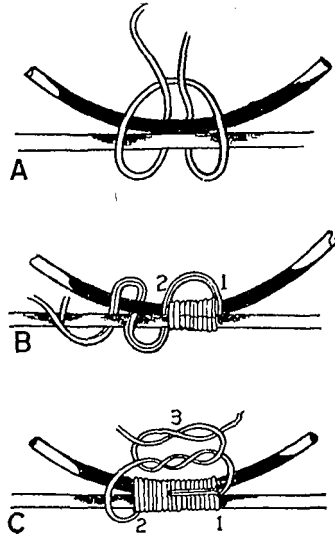

Fig. 6. Fastening springs to spring-edged wire.

where you repeat weaving as before (figure 6B). Then separate the double cord and bring one end under the woven section and up at No. 1 so you can tie a regular sewing knot as at No. 3 (figure 6C). When the springs are tied, the edge wire at the front is directly over the front edge of the seat frame.

In small chairs the seat springs are sometimes tied to spring-edged wire as in figure 6D. Here you begin to tie the spring-edged wire to the top of a spring, starting at the back of the chair. Use tying twine and fasten it down between

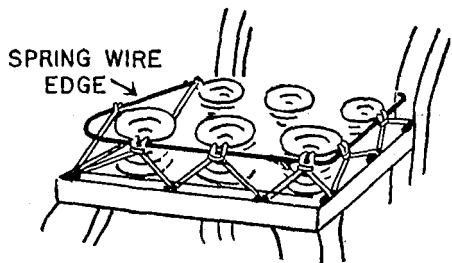

Fig. 6D. Tying springs to spring-edged wire on a small chair.

the springs to the top of the seat frame, wrapping the twine around two tacks there. Bring twine to the spring wire and tie it there to the spring with a clove-hitch knot. Continue this way around the spring-edge wire.

### Tie Springs

Tie each row of springs with tying twine exactly through the center, first from back to front, second from side to side, and last in both diagonal directions. Begin tying seat springs on center row; work outward (figure 3).

Drive two No. 12 tacks side by side, partially into framework directly opposite the center of each spring. Place tacks inside outer edge of frame to leave space for padding and cover tacks (figure 7). Use two tacks to hold the twine, leaving enough space between them to allow cord to be wound around each (figure 7).

Measure twine over springs from back to front so it is twice the distance from the set of tacks in back over the springs to the set of tacks in front.

Begin tying at back of center row of springs. Allow about 3 inches for the twine end. Then loop twine around the two tacks, already driven partially into framework, as shown in figure 7A. Draw twine tightly around tacks and end with twine under the loop, between the tacks. Finish driving in tacks to fasten the end of twine securely.

Work toward front of chair. Tie a "clove-hitch" knot around top coil of spring at point nearest the frame as shown in figure 7.

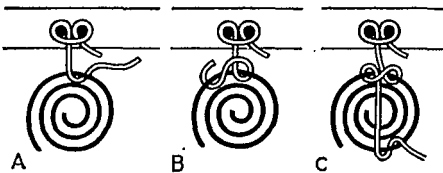

Fig. 7. Tying the clove-hitch knot.

**To make this clove-hitch:** Hold spring down 1 to 2 inches lower than its original height, using the left hand. Use left thumb and group fingers from index finger on to keep spring down.

Tie knot with right hand by placing free end of twine over and under top coil of the spring. Draw to right tightly enough to keep spring in position.

Pass free end of twine over cord and under the wire to the left, leaving a loop in front of the wire (figure 7B), and hold in place with right thumb and index finger. Using left hand, pass twine forward over wire and under the loop forming a figure eight as in figure 7C. To complete knot, pull twine lightly toward you, then release thumb and index finger.

To complete tying of spring, stretch twine across top of spring to opposite side of coil. Make a knot here, repeating steps A, B, and C of figure 7. The second spring, now in position, is tied the same way as the first spring. Continue tying all springs in the row. Do not fasten the twine ends until all rows of springs are tied in one direction; example, back to front springs tied from the back to the front. Then start fastening twine in front seat frame with center row of springs. Fasten twine end to chair frame with two tacks and wind twine around them as before. Fasten tying twine on rows of springs to right and left of center row tightening twine so that center row of springs remains slightly higher than the other rows.

Proceed with similar tying until springs are fastened down in the other lengthwise, crosswise, and diagonal rows in one direction. Knot all diagonal tying over the wires, and wrap twines in the center of each spring. A good rule is to tie the twine over every wire and over every twine which is not to be crossed again (figure 3A and B).

If your chair does not have a separate cushion, tie the springs  $1\frac{1}{2}$  inches lower than the finished upholstery seat



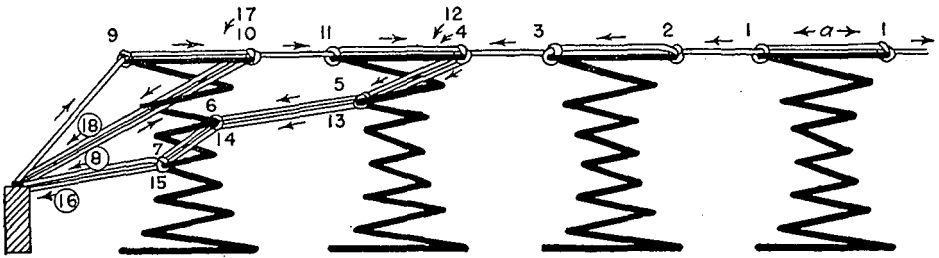

Fig. 8. To tie springs in a large chair, work in direction indicated by numbers.

line, and about 3½ inches lower if there is a loose cushion. If the chair has padded arms, the springs are usually tied level with the lower arm and back stretcher.

**In a Large Chair or Davenport:** In large chairs (figure 8) or davenports (figure 9) where four or more springs are in a row, you will need to make a heavier tying of springs at the front frame edge to steady them. Measure tying twine by laying the twine over a lengthwise row of springs so as to reach from one set of tacks to the other, then triple this measurement.

Start tying the center row of springs and work toward each side frame. Begin at the center of the row, using the middle of your twine. When you reach the next-to-the-end spring, tie as indicated in figure 8. This will reinforce the tying of the second and first springs from the front frame edge. The tying

knots will be gradually lowered to the coil of the front spring nearest the frame edge.

The wire edge supporting the springs should be approximately even with the frame edge at the front of the chair or davenport. This will pull the front springs slightly forward. Then complete cross and diagonal tying so that there are eight knots on each spring as indicated in figure 3.

**In the Back of a Chair:** The softer springs on chair backs require tying in only two directions. If you use an inner spring unit, stitch it to the closely interwoven webbing. Use double mattress twine and follow the procedure used to sew springs to webbing (figure 4A).

The hardest part of your reupholstering is done when the springs are tied. Now the seat and back spring sections look slightly rounded and the springs

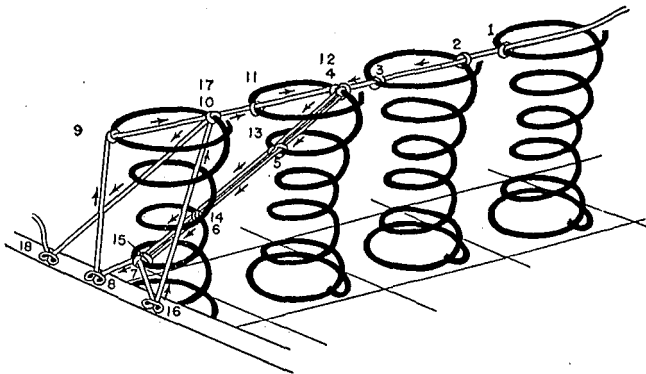

Fig. 9. To tie springs in a davenport, begin at No. 1 and tie knots as numbers indicate.

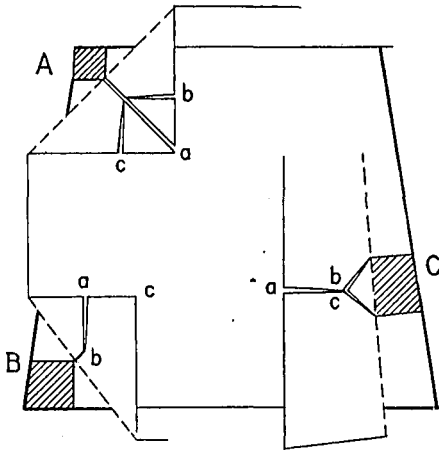

Fig. 10. Fitting material around posts.

- A. When material is to fit on two sides of a post, fold it back at point where it meets corner of post. Cut diagonally from "a" to corner of post. Make two slashes on grain of material to within one inch of end of first cut, allowing enough material to turn under.
- B. When material is to be drawn around front posts, cut from "a" along grain leaving seam allowance. Then cut from "b" to corner post.
- C. To fit material around two corners, fold back close to post. Make cut "a" to within one inch of post. Then cut diagonally from "b" and "c" to each corner.

nearest the frame all tip slightly toward the frame.

### Cover Springs with Burlap

Use firm burlap to cover the springs and make a foundation for the padding on seats, backs, and arms. Plan on  $2\frac{1}{2}$  to 3 yards for an easy chair and 6 to 7 yards for a davenport.

Be sure to lay burlap so the grain runs straight from front to back and side to side. Cut it large enough to cover the springs and extend over the top of the frame to allow 2 inches turn-under on all edges.

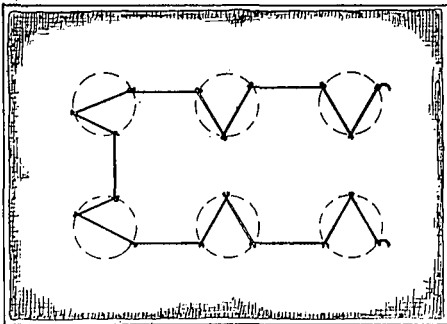

Fig. 11. To sew burlap to top coil of springs, use mattress twine and make a slip knot at three points on each spring.

Use No. 8 tacks and fasten burlap to the frame beginning at the center of each side, then work toward the corner posts. Turn up the edge of the burlap so the fold is on the outside and tack it in place just beyond the tying tacks. Draw the burlap smooth but not so as to depress the springs when you tack it down.

Finish the corners last in order to fit the material around the posts. Figure 10 shows several ways of making these fittings.

To give added firmness, sew the burlap to the top coil of each spring at three places. Use a 6-inch curved needle and enough length of mattress twine so you can sew from one spring to another without breaking the thread. Bring the needle down through the burlap under the top coil of the spring and up through the burlap again where you tie a slip knot. Repeat this knot at three points on each spring, as shown in figure 11. On a wire-edged seat, sew the burlap to the wire with overcasting stitches for greater strength.

### PAD THE EDGES

Padded burlap edges are used on upholstered furniture to keep the padding

in place, to reinforce sharp corners, and to protect the covering from wearing out on bare wood surfaces. These edges (usually some sort of stuffed roll) are put on after the burlap is fastened to the springs.

A narrow edge can be padded with a single stuffed roll as in figure 12. A wide edge will require a stuffed stitched roll.

For a hard edge, stuff the roll with tow, but for a softer roll, moss or hair is better, even when the roll is stitched.

#### Single Stuffed Rolls on Straight Edges:

To save time, use the ready-made spring and roll edging. This comes as jute-filled and paper-filled edging,  $\frac{3}{4}$  inch to  $1\frac{1}{4}$  inches wide. Jute-filled edging is preferred.

To make your own, cut a strip of burlap 5 inches wide and the same length as the edge to be padded plus an inch turn-under allowance. Cutting on the thread of the material will help keep the roll the same width throughout.

Place the burlap strip on the outer edge of the top of the frame with surplus burlap hanging over the edge. Lay a  $\frac{1}{2}$ -inch cardboard strip on the burlap with one edge flush with the outer edge of the frame as in figure 12. Cardboard strips can be ordered from the upholsterer, or you can make them by cutting a  $\frac{1}{2}$ -inch strip from 8-ply weight smooth, poster cardboard or similar weight paper.

Using No. 6 tacks, fasten both burlap and cardboard to the frame, keeping tacks well in from outer edge of the frame and spacing them  $1\frac{1}{2}$  inches apart. On a rounded or square corner, fold the burlap in dart-like folds before tacking it down.

Put enough stuffing on the burlap to make a firm roll, usually 1 inch high. Roll upward to the inside frame and there tack it down inside the first row of tacks. Keep the edge of the roll even with the edge of the frame.

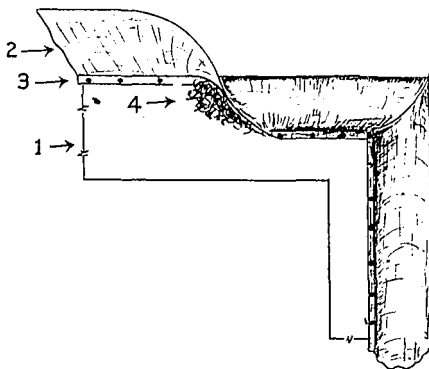

Fig. 12. Use a single stuffed roll to protect straight edges: 1. Frame; 2. Burlap; 3. The  $\frac{1}{2}$ -inch cardboard strip; 4. Stuffing.

#### Single Stuffed Rolls on Curved Surfaces and on Frame Edges:

A well-constructed chair or davenport will have a single stuffed roll tacked to the front or inner side of the back frame, edging the top and sides of the frame, also along the inner edge of the front arm pieces as in figure 13, and on the edges of the top arm piece.

**For Curved Surfaces:** Make this roll from a bias strip of firm burlap 5 inches wide. Use No. 8 tacks and tack one edge of the strip close to the outer frame edge. Stuff with tow, moss, or hair to make a firm roll  $\frac{3}{4}$  inch thick. Place roll so it comes just to the outer edge of the frame. Taper stuffing at the ends. Then bring burlap firmly over the padding and tack it to the inner edge of the frame or arm piece.

A single stuffed roll should also be used on the outer edge of chair and

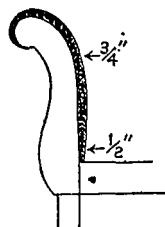

Fig. 13. Pad curved surfaces with a single stuffed roll.

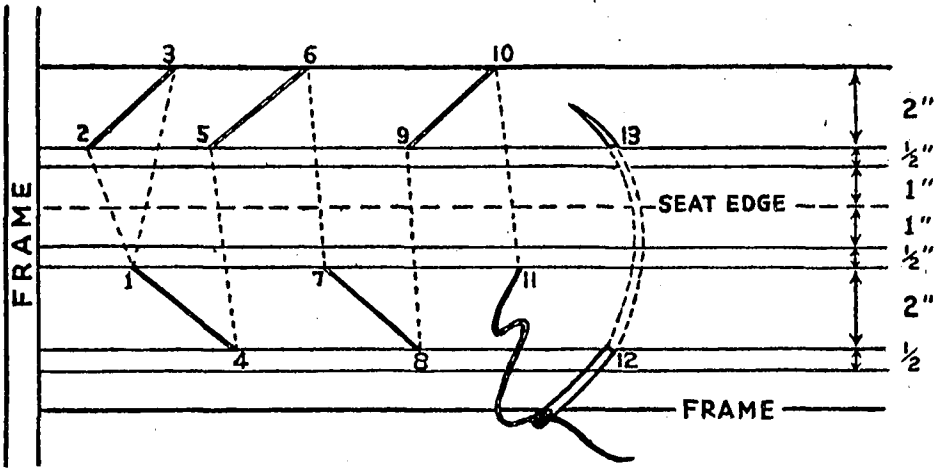

Fig. 14. Lines spaced above and below the front seat edge show where stitches are taken to make padded edges.

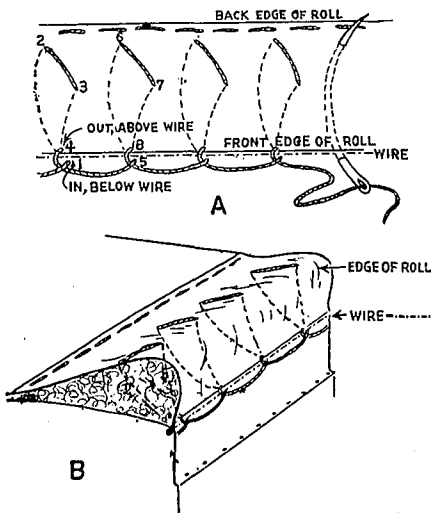

Fig. 15. A. Direction of stitches for a roll on a wire edge. B. Side view of roll stitched to a wire edge.

davenport arms. For wide chair and davenport arms, fasten the rolls on both edges. These rolls lessen wear, hold padding in place, and give good lines to a piece of furniture. On straight edges, remember to use the 1/2-inch

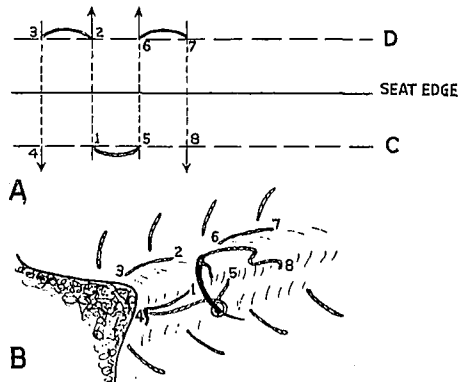

Fig. 16. For a wire edge that is firm and stands high, stitch roll one or more times just above first stitching. Use a curved needle and mattress twine.

strip of cardboard—it helps to keep the edge straight.

If you are protecting the wing edges of a wing chair, use bias burlap for your single stuffed roll.

**The Front Roll on the Seat Section:** If the original front seat spring-edge roll is in good condition, plan to use it. If not, make a new one following the procedure in figures 14, 15, and 16.

This front seat roll, which is a stuffed roll with stitched edges, adds greatly to the durability and appearance of seats in large chairs and davenports. Use it to make a very firm edge and also to reinforce unusually deep seat-spring sections of these pieces.

**The Front Seat Roll:** Cut a strip of burlap wide enough to extend four inches back on the front seat edge and down over the edge of the frame. Usually this strip is 10 inches wide.

Make a china pencil or chalk line on the burlap covering the spring section, 4 inches back from the seat edge. Turn under an edge of the burlap strip to this line and stitch the strip there to the foundation burlap with half-inch running stitches. Slip-tack (partially fasten tacks so they can be removed) the lower edge of the strip to the frame or use your upholsterer's pins.

Leave a 3-inch space at each corner and work your moss or tow with an ice pick smoothly and firmly into this opening. Stuff the opening so it extends upward about  $1\frac{1}{4}$  inches and slightly outward ( $\frac{1}{2}$  inch) to hold the cushion in place. Fold extra burlap at each end under the stuffing and miter corners. Recheck the slip tacks or upholstery pins on the underside of the roll and see that they are on a straight thread of burlap to guide you in stitching.

When this roll is used on a seat with a wire edge, stitch the strip to the foundation burlap on the seat. Then place the stuffing evenly under the strip, turn the lower edge under even with the wire, and overcast it there with a curved needle.

**Procedure for Stitching Edge Rolls:** Stitch edge rolls with mattress twine to give a firm and high edge to the roll. Method of stitching depends on height of padding above the frame, amount of firmness needed, and whether you are fastening the roll to foundation burlap or wire edge under the seat edge.

If you do not have a wire edge and are making a small edge roll to pro-

tect the edge of the seat, finish it with long stitches to hold the top and front firmly in place. To plan the place for the stitches, pinch up the edge with your fingers, then put a chalk or pencil mark at these lines. Usually they come about 1 inch above and below the seat edge. Draw two lines on top to show where to take the long stitches (figure 14). The first of these can be  $\frac{1}{2}$  inch behind the line for the edge roll; the second is placed back from the edge 2 inches. Then draw two lines across the front of the padding: the first  $\frac{1}{2}$  inch below the edge roll stitch; the second as low as stitches can be taken (usually  $\frac{1}{2}$  inch above the seat frame).

Use a 6-inch straight needle with a long, single strand of mattress twine. Knot the twine, and begin stitching at the left-hand side as in figure 14. Insert the needle at 1, bring it out at 2, insert needle again at 3, and bring it out at 1. Tighten the twine. Then proceed: insert needle at 4, out at 5, insert at 6, and out at 7. Tighten the twine and insert needle at 8, repeating stitches across the seat so they are about  $1\frac{1}{2}$  inches apart.

On a wire-edged seat the edge roll stitching is done differently (figure 15). Thread a 6- or 7-inch curved needle with a long, single strand of mattress twine. Do not knot the end. Note that the second row of stitching is made just in front of the first row.

Enter needle at 1 under the wire, bring out at 2, in again at 3, and out at 4 just above the wire. Now tie the loose end of the twine at 1 around 4 and tighten the stitch, pulling to the right. Keep the needle at right angles to the roll to draw a larger amount of the stuffing to the finished edge. Loop thread as indicated in figure 15 and continue across the roll, pulling to the right to regulate the stuffing as you work.

You can obtain a firmer and higher edge by stitching one or more times after the first stitching. This is done

with a curved needle just above the first stitching (figure 16A). Enter needle at 1, bring it out at 2, insert again at 3, and bring it out in front at 4. Make a slip knot in the end of the thread hanging at 1. Put the needle through the slip knot and pull twine through (figure 16B). Tighten the stitch by pulling to the right. Now insert the needle at 5, out at 6, in at 7, and out again at 8. Slip the needle under the twine at 5 and tighten the stitch, pulling to the right so that the needle end of the twine is pulled back to 8. This makes a loop between 5 and 8. Repeat, making stitches an inch long, always pulling to the right after slipping the needle through the loop preceding it.

You control the shape of the roll by the stitches you take. To make the roll edge higher, space the rows of stitching widely in front of the roll; to make the top edge lean forward to overhang the wire, place your stitching rows close together in front and separate them widely behind the roll.

## NOW, THE MAIN PADDING

**Padding Supplies:** A ½-inch layer of fine tow next to the burlap covering the seat section.

Moss or hair, usually 2 inches thick, placed over the tow so springs cannot be felt when pressed down. Count on 12 to 15 pounds of moss to cover the seat, back, and arms of a two-piece suite.

Curled hair or medium-grade rubberized curled hair sold in sheets can be substituted for moss to add resilience and long life to padding. Both are more expensive than moss. Rubberized hair comes in 24 x 72 inch sheets and in 1-, 2-, and 3-inch thicknesses.

Several layers of cotton felt to cover the front seat sections, inside arms, and inside back. Cotton felt weighs 16 ounces to a yard. Estimate amount needed by measuring sections to be covered. Usually 10 pounds of cotton

felt are allowed for a chair and 22 to 25 pounds for a davenport.

## Padding the Seat Section

The procedure which follows offers pointers for padding the seat of a chair. Handle the platform of a davenport similarly.

Place padding (tow, curled hair, or moss) on separate sheets of newspaper. Fluff each material with an ice pick to free it from lumps.

Shape to cover the entire seat area with exception of the front edge where padding should come only to the back of the seat edge roll.

Stitch tow and moss to the burlap using your large curved needle and a long strand of mattress twine. Sew with large stitches as in figure 17. Start stitching the second row about 2 inches inside the first row. Stitch around and around, keeping same spacing until center is reached, then fasten twine there. Tighten each stitch to make padding more firm.

Next, place a layer of cotton felt over the stitched padding. Cut so cotton barely meets the side and back seat frame edges. The front should reach to the first stitching of the edge roll.

Make additional padding to fill in the front and back corners of the seat. To do this, cut triangular pieces of cotton felt to fit the corners exactly. Shape so the base line of each triangle just meets at the center front and back

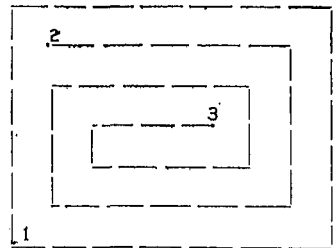

Fig. 17. To stitch padding to burlap, take long stitches from outside in to center.

frame edge and also at the center of the side seat frame. A seat without a separate cushion usually requires two or more triangular pieces to build up the corners.

Place a second layer of cotton felt, cut exactly the same size and shape as the first seat piece, over these cotton layers.

### Double Padding for the Seat Section

A double padding adds to the stability of the seat and is worth the effort. Cut a second piece of burlap for this to cover the seat and extend 4 inches below the seat frame.

Place burlap over the stitched tow and moss and slip-tack it to the frame. Use a long straight needle and stitching twine to make long stitches around the outer edge and down through the first burlap. Keep the stitches just inside the seat frame. For reinforcement, pattern your stitching as you did for the padding, then your stitches will again take the shape of figure 17.

After this, release the slip-tacks from the edge. Add enough stuffing under the loosened burlap to make a firm and even edge where it is tacked to the frame. Complete the padding in either of the following ways:

1. **For a seat without a separate cushion**, the edge need not be stitched, but a firmer seat edge results if the stitched stuffed roll is made (figure 14). Follow either finish with a final padding of moss or hair and stitch it to the burlap. Cover this with upholsterer's cotton, then with muslin, and finish with outside cover.

2. **Seats with separate cushions** should be reinforced with a stitched stuffed roll either across the front or across the front and sides. Pad this roll so it extends upward and slightly outward to hold the cushion in place.

After this, cover the seat up to the first stitching of roll with a thin layer of moss or hair, and a layer of cotton.

### APPLY FABRIC TO SEAT SECTION

There are several ways of applying fabric to the seat section. If you are slip covering the piece, use muslin. If the seat is without a separate cushion, you can complete it with outer covering material, but a muslin cover under this lessens slippage of the outside fabric and adds contour to the piece. In a chair or davenport with a separate seat cushion, the section under the cushion is usually covered with denim, sateen, or similar firm fabric up to the front edge roll where a piece of outer fabric covers the roll. In any case, the procedure used on the original cover offers guidance for handling the cover material.

### Muslin Cover for a Seat without a Separate Cushion

Use firm unbleached muslin. Center it at back, front, and sides of the padded seat. Cut so you can pull muslin beneath the back stretcher. Tack it in the middle on the outside of the back seat frame. Allow enough material in front so muslin can be pressed firmly forward over padding and tack at middle of front seat frame. Pull fabric taut over sides and allow enough to tack it on the middle of the side frames. To strengthen tacking, allow  $\frac{1}{2}$ - to  $\frac{3}{4}$ -inch turn-under on all sides. Another method is to determine necessary size by your old cover, but allow 2 inches on all edges for ease in tacking.

Place muslin over the seat padding so grain of fabric is straight. Start at center of the seat and pull muslin down under the back rail as far as possible to the center back frame. Hold it there, turn an edge under, and slip-tack to midpart of the back frame. Tack muslin so the seat padding is firmly and evenly in place. Tack from side to side of center back frame, to within 3 inches of the corner posts.

Place your next tacks in the center front frame. Firm the padding by pulling muslin from center back to center front. Be sure all lumps and hollows are evened out and again, fasten tacks to within 3 inches of the ends of the front seat section or if armposts are there, to within 3 inches of them. Tack sides from the center to same distance from the posts.

Now make diagonal slashes as needed to fit around the posts and corners as in figure 10. Draw muslin into position around posts. Turn edges under and tack in place. Fit fabric around back posts first, making side edge folds, then back and front folds which should fall in position over the side folds.

If a slip cover is used, tack muslin on underside of seat frame. If the seat will be covered with upholstery fabric, bring muslin close to edge of frame where a fabric-covered cord will finish the seat. Pin it there and sew with a curved needle to burlap below or tack it to the seat rail a short distance below the front seat edge.

### Upholstery Fabric for a Seat without a Separate Cushion

If old cover is used as a pattern, be sure to add a 2-inch edge allowance all around for ease in handling.

Center fabric on seat. If a striped pattern is used, try to bring darkest strip close to outer side frame edge to accent shape of chair. Try to keep grain of material straight. Cut so you can tack fabric to underside of back seat frame and allow  $\frac{1}{2}$  to  $\frac{3}{4}$  inch to tack it to cording at base of front and side seat frames.

Using No. 6 tacks, tack a strip of fabric-covered, welt cording around inner edge of back posts with seam edges extending against seat padding. Front posts may also be corded, but more often the smooth effect of covering fabric is desired there. Also tack cording at 1-inch intervals along bot-

tom edge of seat frame at front and sides of chair. End cording at post edges with a turn-under allowance. To make cording see page 22.

Fasten fabric first at the back. Draw it taut on grain of material under the back rail and tack on underside of back seat frame. Tack from center back to within 3 inches of back posts.

Now draw your upholstery fabric firmly forward over the cotton felt to the front seat corded edge. Make a  $\frac{1}{2}$ -inch turn-under and use upholstery pins to hold it in place just above the cording. Check the tautness of your padding as you firm it from center back to center front, side to side, and on out to within 3 inches of the chair posts.

Cut fabric around posts as in figure 10. If you are using medium or lightweight fabrics, make the first turn-under at the side post edge, then bring the front or back section of fabric over it, fold and pin in place.

Final fastening of fabric is done with plain or hammered brass furniture nails placed closely together above the corded edge. Or the fabric can be sewed with heavy-duty thread of matching color to a corded seam line.

### Covering a Seat with Separate Cushion

Make this seat cover under the chair cushion in two sections. One, of denim, sateen, or similar firm fabric to cover the seat up to the back of the front seat roll; the other, of outer fabric to cover the roll.

Gauge the size of sateen or denim seat piece from back of front seat roll to back and side tacking rails. To strengthen tacking, allow  $1\frac{1}{2}$  to 2 inches of fabric as turn-under allowance on three sides and a  $\frac{3}{4}$ -inch seam at the front edge.

Cut a straight piece of outer fabric covering material for the front seat roll section the length and depth of this area, plus 2 inches on either side for



handling. If extra strips were attached to either side of the old front seat section, cut similar strips plus 1½-inch tacking allowance and use them to fasten cover to base of your chair.

Mark center points of sateen or denim and front roll piece. Pin together with ¾-inch seam and machine stitch on seam line. Turn seam to front of chair and pin center of it to center of chair just back of front roll. Pin entire seam in place, and stitch to burlap base with double strand of heavy-duty thread.

Lay sateen or denim seat piece over padded seat area. Draw it firmly on grain of material under the back rail. Turn under a ¾-inch tacking edge and tack with No. 6 tacks to lower half of back seat frame. Tack first at center back, then to within 3 inches of corner posts. Fit material around back posts (figure 10A). Turn raw edges under and tack ¼ inch from outside frame edge.

Lay front roll section of outer fabric back over sateen. Cut a piece of cotton felt to fit in front seat area extending below the front roll to top edge of seat frame. Cut another piece of cotton felt wide enough to extend from the stitched seam at back of front roll to the same seat frame edge. Now draw your upholstery fabric firmly forward over the cotton felt and slip-tack it one inch down from top of seat frame. Tack, on grain of fabric, to within 3 or 4 inches of corners.

Miter fabric at end of front seat roll. Fold back extra material at each corner between arm section and side of seat. Pin a fitting line there and transfer seam to wrong side. Sew and cut away excess fabric.

Make sure the front seat piece is taut. Mark point on corners where fabric must divide. This will be where front seat frame and arm post meet. Make a diagonal cut here. Then pull longer strip through side opening on chair and slip-tack to back of front arm posts. Firm fabric covering this area and tack permanently.

Chairs with separate cushions require back and arm upholstery before the front seat section can be completed.

## UPHOLSTERING THE CHAIR BACK

### Chair Back without Springs. Frame Uncovered

This type of chair usually has a finished wooden arm piece and the inside and outside back sections are fastened to the frame with a row of closely spaced furniture trim nails.

Place the chair so the inside back faces you. Tack webbing on inside back frame first. Fasten strips with No. 6 tacks on inner half of frame and interlace them as you did in the seat. Cover webbing with burlap cut to fit inside back section plus a ½-inch turn-under and tack it with No. 6 tacks just beyond the webbing strips.

Place an even 2-inch layer of moss over the burlap and use long stitches of sewing twine to fasten it to the burlap. Usually more moss is put at base of inside back section for back comfort and often at the top for shape. Cover with a layer of cotton felt which barely covers the inner frame edges all around. Slash cotton at arm posts so it lies perfectly smooth.

Now, tack on a firm muslin cover, spacing No. 4 tacks 1½ inches apart so muslin comes just inside the outer covering tack line. Always slip-tack at first, then after fabric is smoothed in place, finish with permanent tacking. Center muslin on grain of material, tack it down firmly over padding with a ½-inch turn-under allowance. Start tacking from center at base of the back frame on out to the sides. Then pull muslin taut and tack similarly at top of frame. Tack sides from center out to corners. Fit material around arm posts or corners (figure 10). If reinforcement is needed at arm posts, insert cording. See paragraph on cording, page 22.

Put on the outside cover, handling it the same as the muslin cover. For straight edges, use cardboard tacking strips under the cover fabric with one edge nearly flush with the outer frame edge as in figure 12. Use the outer edge for final trimming effect with a row of closely spaced furniture trim nails.

Then finish the outside back of the chair. Cover it with burlap and pad with cotton if necessary. Otherwise cover with muslin and apply outer covering material. Handle both fabrics the same as you did the inside back.

### Chair Back without Springs, Frame Covered

Web inside back of this chair and cover with burlap as for chair back with an uncovered frame.

Make a double padding carrying second burlap cover to back of top frame and slip-tack it there. Stitch this padding as in figure 17, placing first row of stitches 2 inches inside the frame edge. After stitching is complete, release burlap from back and place hair or moss evenly up to the stitching so that the frame edge is well padded. Be sure you don't change contour of back frame.

Cover inside back with an even layer of cotten felt. Cut felt so that you can tuck it in close to the seat frame at base of inside back. See that it tapers off evenly at top and side frame edges.

Apply muslin cover, centering it at top and bottom of inside back section. Pull bottom end of cover through to back of chair and slip-tack it in center of seat frame on outside back edge of the frame. Smooth muslin firmly upward and tack at center top on outside edge of the frame. Tack from bottom to top and from center toward the corners. Then tack sides in the center on outside frame edge.

At seat line, push muslin on a fold down to farthest point at one corner. Hold finger there and mark with a pen-

cil. Then cut a diagonal slash from corner to this point. Fit and cut muslin in same way at other corner. Again pull bottom end of muslin to back seat frame and tack it there.

Using the back of your shears, push muslin on a fold into crevice from seat corner up to top arm stretcher. Now fit muslin around curved part of arm. To do this, hold muslin firmly in place, then make slashes where necessary to release fabric and make it fit smoothly around the curve. Make first cut at inside top edge of upper-arm stretcher where arm begins to curve. Make second cut at right angles to inside back at point where inside back curve resting on top arm piece is greatest. You now have a large flap of muslin resting on the arm piece. Cut this off to within 1 inch of inside back padding. Slash in deeper if necessary to ease muslin against inside back. Make as many more cuts as are needed. Then tack muslin on back frame. Repeat these steps on other side of chair. If muslin does not fit smoothly where slashes are made: the cuts are not deep enough; or there are not enough cuts; or more padding is needed.

To complete muslin covering over inside back, stretch fabric firmly in position on grain of material. Tack on straight of goods from arm toward upper corner of chair on back frame, also as far as you can, from center top toward corners. Take up all remaining fullness in one large dart, then divide this in half and pin fabric to chair at this point. Divide again in quarters, then in eighths, and so on until the fabric is pinned in 1- or 1½-inch folds. Use these folds to lay ½-inch or ¾-inch darts. Tack darts in place on outside back frame edge with line of the dart on thread of the goods in as far as possible.

If chair is to be left covered by muslin, as for slip covering, tack bottom of inside back piece to seat frame. If you are applying upholstery fabric, tack

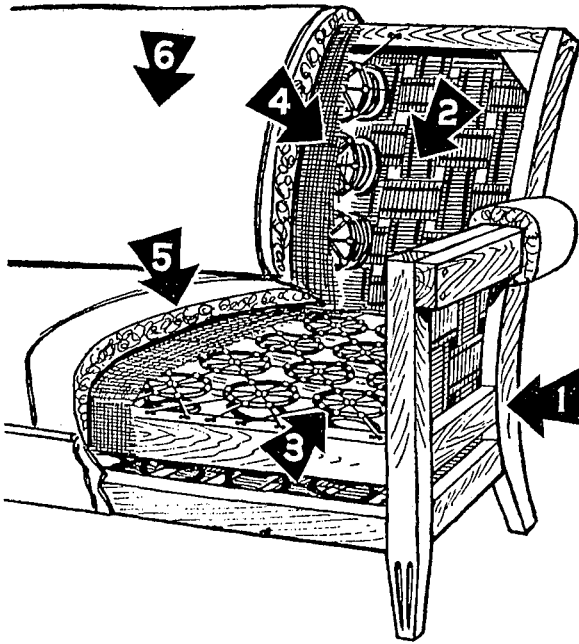

Fig. 18. This chair shows materials involved in reupholstering furniture.

1. Strong frame, well braced, clean, and all old tacks removed.
2. Foundation of interlaced webbing for back, seat, and inside arm sections.
3. Seat springs tied eight times and back springs usually tied four times.
4. Firm burlap covering spring sections.
5. Padding of tow, moss, and cotton felt. (Sometimes curled hair or rubberized hair takes the place of moss.) Muslin covering holds padding in place.
6. Outside cover fabric shows corded seams at points where wear is greatest.

muslin to lower back stretcher. Then, when you apply upholstery fabric on this section, follow same procedure as for muslin but tack covering material firmly to seat frame, to make back and seat fit tightly together.

The outside back piece is put on last, after other sections of chair are completed. Directions for applying are on pages 22 and 24. If back frame has straight edges, attach back cover to top frame with a blind tack strip (½-inch strip of cardboard). Place this strip on the under side of cover material. Tack it and the cover fabric with No. 6 tacks to seam line of inside and outside back pieces on the top frame. Then, bring back cover into position on bottom and side edges and tack them to frame with ¾-inch turn-under of fabric.

### Chair Back with Springs

Tack webbing to outside back frame edge with No. 8 tacks. Sew springs

to interlaced webbing, and tie only 4 times lengthwise and crosswise with clove-hitch knots. Cover with and stitch burlap to the springs (figure 11).

Place an even 2-inch padding of tow and moss or hair over the inside back section so that it just covers the frame edge. Fasten it with long stitches to the burlap underneath as in figure 17. Cover with a pad of cotton felt, and then with muslin. Apply muslin cover on inside back according to directions given in preceding section.

### Boxed Strips as Part of Inside Back

Often, boxed strips extend from the back of the top arm stretcher up to and over the corners of the chair. Be sure to cut and fit strips on grain of the material so that lengthwise threads run straight down to top arm stretcher. Machine-stitch fabric-covered cording on the fitting line to the inside back piece.

### Chair with a Tufted Back

Tack webbing on inside back frame. Cover with burlap which has been cut with a ½-inch turn-under allowance. Tack this allowance just beyond webbing with No. 6 tacks.

Use old tufted cover as a guide and mark position for tufting buttons on burlap. Mark outside cover also. Allow enough material between buttons so that each tuft can be padded. Place outside cover over burlap, matching button positions. Then pin burlap and cover together at markings.

Fasten first row of buttons at base of back with stitching twine, sewing through the covering, burlap, and webbing. Fasten each button separately, tying it on the webbing. Fill the row of tufts with hair or moss until it is well shaped and firm. Sew on the second row of buttons and fill the newly formed tufts. Continue until all buttons are on and you have filled all the tufts.

Lay pleats of appropriate depth in cover fabric. Tack edge of fabric to top of outside back frame so that the fold of each pleat will be in line with buttons. Make each fold as a row of tufts is completed. A ½-inch cardboard strip tacked at the tacking line helps to hold pleats in place.

## UPHOLSTERING THE ARMS

### Apply Webbing or Burlap Foundation

If you are upholstering a heavy piece, web the inside arm section. Tack webbing from lower-arm tack rail to inside edge of top arm stretcher. Interlace strips from back to front arm posts. Cover with firm burlap, and sew a 2-inch padding of moss to it with long stitches. For medium-weight pieces, omit webbing and tack firm burlap to cover inside arm section. Tack burlap with a ½-inch turn-under all around on same parts of frame indicated for web-

bing this area. Stitch a 2-inch layer of moss to burlap.

### Pad the Arms

When you took off the old cover, you saw whether the arms were upholstered first. If so, reupholster them first. Usually, however, arms are padded after the seat and inside back are completed.

First, apply a single-stuffed roll of burlap (figure 12) to inside edge of front arm piece. End this roll where it meets outside arm piece at the top. If the top arm is wide, apply a double roll to hold padding in place. Make double roll of burlap, long enough to cover top arm area and to hang 6 inches down on each side with an extra inch at each end to tuck in around padding later. Tack roll through the cardboard tacking strips on inner and outer top arm edges.

Cover moss on inside arm section with a layer of felt, cut large enough to tuck into crevice at seat-line and to come to outer edges of inside arm section.

### Apply Muslin Cover to Inside Arm Piece

Place muslin over inside arm padding so grain of fabric runs up and down from seat to outside arm piece. Cut muslin long enough to cover this section, with a lower tacking allowance to come to the seat frame. Muslin should be wide enough to cover entire inside arm from front to back and to fit firmly around arm at front or to come to cording line on inner curve of front arm piece according to style of chair.

1. At center of inside arm piece, pull muslin under the lower arm rail, and slip-tack it on center of side seat frame. Place 1 or 2 tacks on either side of the center tack. Then stretch muslin from seat to top arm piece, and tack it on outer edge of this piece directly above tacks used at seat frame. Pin muslin to arm temporarily so that it cannot be pulled off center.

2. Fit lower back corner first. Stretch muslin tightly to inside lower corner and mark point where arm, back, and seat meet at corner of the back post. Fold material back and make a diagonal slash to this point.

3. Again pull muslin under the lower arm rail and slip-tack it from center point to the back post. If final cover of upholstery material is to be used, tack muslin to lower arm rail; if chair is to be slip covered, tack muslin to seat frame.

4. Stretch muslin tightly toward inside back. Fit at seat line and on up to top arm stretcher, following same procedure used for fitting inside back muslin cover at these same points.

5. Pull muslin between cuts through to outside frame. If final cover is to be of upholstery material, tack muslin to the back arm frame; for slip covering, tack it to the back frame.

6. To fit muslin over curve of arm at point where arm and inside back meet, make slashes as you did for the inside back, to permit fabric to fit smoothly around the arm curve. Tack muslin on side and back of the back post.

7. Stretch muslin tightly from center of inside arm to inside corner of front arm piece. Mark this point and slash on grain of fabric from the bottom edge up to mark. Draw muslin through under arm rail and tack as before.

8. To fit muslin around front arm piece, follow old pattern. If inside arm piece is to cover front arm of chair, pull it firmly over the front arm and tack it on outer edge of this arm piece. Center first tacks on this edge. Then fit, slash, and tack muslin as necessary. Work from lower corner upward, and tack to within 2 inches of the top. Fit muslin around arm at top. Pull fabric over arm, and tack along outside edge of arm from center toward the front. Stop tacking one inch from front corner. Pull fabric firmly over the edge and cut off surplus material in a line following curve at top of front arm piece. Allow

a ½-inch turn-under on front material. Draw it firmly to the top arm piece and pin it there. Use a small curved needle and linen thread to sew muslin around curve at top of front arm piece.

If muslin is to be tacked in pleats over curve of front arm piece, hold fabric with the grain straight across the inside of arm piece. First, tack muslin from center to the bottom frame. Pull fabric downward and cornerwise when fitting and tacking it. Tack from center upwards. Make pleats as you fit muslin around the arm curve. Space pleats evenly and turn folds downward. Pull each pleat taut and slip-tack with No. 4 tacks. Tack underside and top of each pleat. When all pleats are in position, drive tacks in permanently.

**Note: To fasten upholstery fabric,** follow procedure used for muslin but tack upholstery material to seat frame to close space between arms and seat.

Cut front arm piece of cover fabric with ¾-inch seam allowance on all edges. Match design of figured material so that it falls in exact position with same design on the inside back.

If chair is a Lawson type, or if front arm piece was corded before, or if front arm piece is to be pleated, you should cord the inside edge with fabric-covered cording.

**Cording Front Arm Piece.** Pin and machine-stitch covered cording to inside edge of straight strip for the front arm piece. End cording where outside arm piece joins end of curve on front arm piece. Press and check to make sure that cord lies on arm edge. Slash edges of corded seam so that it fits arm edge smoothly. Slip-tack front arm piece in place. Keep corded edge exactly on edge of the arm. Complete this section as you did the muslin cover at step 8.

9. Cover lower edge of front arm piece if chair style requires this. If seat material has been left loose over front edge roll, slash it so that it lies smoothly against base of front arm piece. Tuck in the slashed edge to overlap raw

slashed edges of arm covering and tack to outside edge of arm. At bottom inner corner where leg meets seat, slash fabric to make two tacking strips. Tack one strip under the seat frame. Turn the shorter strip across leg and base of front arm piece and tack to outside of arm.

**Wings.** On a wing chair, cover wings after inside back is covered. To re-pad them, remove nails or screws which hold wings to back of chair. Tack firm burlap over sides and top of wing. Then stitch a layer of moss to the burlap. Fasten wings back in place.

Place a layer of cotton felt to extend just to outer frame edges. Cover with muslin cut to fit wing with 1-inch tacking allowance. Draw fabric so that grain runs up and down. Tack muslin on back of wing to back frame of chair. Pin and slip-stitch it at the front to inside back muslin cover. At the base where wing and arm piece meet, make slashes so muslin will lie smoothly in crevice.

### Apply Muslin to Outside Arm

Cut a muslin cover for the outside arm piece approximately 1 inch larger than old cover. Be sure to fit fabric on grain of goods. Turn in top edge of muslin to meet outside edge of top arm section and pin in place. Turn front edge in and pin so that it meets outside edge of the front arm post. Tack back edge to back frame. Draw muslin down firmly and tack to underside of seat frame. Slip-stitch top and front edges to fabric there.

**Note:** On most chairs, muslin is not applied to outside arm piece until lower front seat section is completed. Refer to step 9, page 21 and following paragraph.

### APPLY MUSLIN TO LOWER FRONT SEAT SECTION

On many chairs it is necessary to cover the horizontal strip along the lower front seat section after seat material has been fitted around front arm

piece. To do this, cut a strip of muslin the depth and width of the area with turn-under allowance. If there is a board underneath, tack top edge of muslin to it; otherwise, back stitch muslin to seat cover. If tacking fabric, place a cardboard strip with top edge of muslin  $\frac{3}{4}$  inch underneath it. Drive No. 6 tacks one inch apart near edge over which you will fold muslin to cover front section.

Turn side edges under and, according to style of chair, either sew them to cording on front arm piece or tack to outside edge of arm. At bottom inner corner where leg meets the seat, slash muslin and tack one part under seat; then turn shorter piece across leg and tack on outside of arm. Pull fabric taut from top to bottom and tack beneath front seat frame. The outside arm piece may now be fastened in place.

### APPLY MUSLIN TO OUTSIDE BACK

After outside arm piece is in place, fit muslin with  $\frac{3}{4}$ -inch turn-under on top and side edges of outside back. Pin and slip-stitch in place. Pull muslin firmly to base of back and tack on  $1\frac{1}{2}$ -inch allowance to under part of seat frame. Fit smoothly around legs and tack.

**Cording.** Cording should be used on boxed edges of a reversible cushion and on front edge of chair arms from point where outer curve on arm begins and following that line down to seat frame. Cording adds to tailored effect if used to finish the bottom edge of seat arm and back pieces. After outside arm material is in place, cording is usually applied to top and side edges of back from one arm piece to other arm piece.

Select cotton-welt cording of suitable thickness to use with your fabric. Estimate amount needed by measuring sections to be corded, or if old cover is your guide, measure cording used there.

Make cover for the cording of your upholstery material. Usually  $\frac{1}{2}$ - to  $\frac{3}{4}$ -

yard is fabric allowance for cording a chair, 2 yards for a davenport, and 1½ yards for davenport cushions.

On curved sections of furniture, use bias strips of covering material 1½ inches wide to cover cording. On straight edges, use straight strips 1½ inches wide. Attach a cording foot to your sewing machine. Stitch fairly close to cord with heavy-duty thread which matches the background color of your fabric. Stretch the covered cord and sew it where needed, to outer cover fabric.

To keep cording flat where it is joined, pull cord out of cover fabric and cut off ½ inch. Then slip empty end of cord under section you are stitching.

Tack cording with No. 6 tacks at 1½-inch intervals to wood frame so that corded edge is even with the frame and seams lie against frame. You may sew cording with a small curved needle to the burlap-covered frame.

### APPLY THE OUTSIDE COVER

A slip cover is often used as the final cover on upholstered pieces. To make one, see directions in Minnesota Extension Leaflet HF 9.

If outside cover is of upholstery fabric, apply to each section as follows:

1. Cover seat of chairs without separate cushions first. Apply fabric according to style of piece. For example, you might tack the muslin cover and upholstery fabric to under part of seat frame; or you might set cording in the upholstery material across front edge of seat to strengthen this edge.

Chairs with separate cushions require back and arm covering first. After these sections are covered, backstitch cording at desired break across front seat edge with a curved needle and heavy-duty thread. Then cut a strip of upholstery fabric to cover lower front seat section with top and bottom tacking allowance and turn-under allowance on sides.

Place thin layer of cotton under fabric. Pin covering material in place. If possible, use a tacking strip and tack top edge of fabric to front seat frame. Sew side edges and tack lower edge to underside of seat frame.

2. Apply upholstery fabric to inside back section following same procedure as you used for muslin cover.

3. Fasten upholstery fabric to inside arm sections following procedure used for muslin, but tack upholstery material to seat frame to close space between arms and seat.

If separate front arm piece is needed, cut cover fabric with ¾-inch turn-under allowance on all edges. If using a patterned fabric, match design so that it falls in exact position with same design on the inside back.

If chair is a Lawson type, or if front arm piece was corded before, or if this piece is to be pleated, you will need to cord the inside edge with fabric-covered cording. To do this, pin and machine-stitch covered cording to inside edge of straight strip for the front arm piece. End cording at point where outside arm piece joins end of curve on front arm piece. Press and test to make sure that cord lies on arm edge. Slash edges of corded seam so that it fits arm edge smoothly. Slip-tack front arm piece in place. Keep corded edge directly on edge of the arm. Complete this section as you did the muslin cover.

4. After seat, inside back, inside arms, and, in some cases, the lower front seat section are in place, cut outside arm piece with tacking allowance at top, bottom, and back edges and with a turn-under allowance where it meets chair arm. Use a tacking strip at the top and pull fabric over it to get a firm, smooth edge. After this, pin material in place on outside arm and trim to desired shape. Sew front edge to seam line of front arm piece. Then tack back edge to chair frame and bottom edge to underside of seat frame.

If front arm piece was finished with a lightweight wood strip covered with fabric, now is the time to complete it. Cover board with a thin layer of cotton and then with upholstery fabric to correspond to original cover. Use four thin tacks to fasten this strip in place. After tacking, pull strip out slightly to release fabric from tacks, then retack.

5. To finish the outside back, pin a continuous strip of fabric-covered cording around the back seam edge from one arm to the other. Center upholstery fabric with pins. Turn raw edges under  $\frac{1}{2}$  inch and blind-stitch this piece to the corded edge with a small curved needle and heavy-duty thread to match outer fabric. You may tack in place with gimp braid and gimp tacks or with furniture trim nails. Blind-stitch lower sides to outside arm pieces. Tack bottom of fabric on underside of seat frame.

If back frame has straight edges, tack fabric with No. 6 tacks to top frame on a cardboard tacking strip. Then bring back cover into position on bottom frame and tack it there. Sew side edges in place.

6. Turn chair upside down. Tack black cambric to base of seat frame with  $\frac{1}{2}$ -inch turn-under all around.

**Note.** Some pieces look better when a flounce is added to the base of the seat frame. Cut front, sides, and back pieces separately. Allow enough material to make a 4-inch inverted pleat at each corner. The material must be deep enough to cover space between lower edge of seat frame and must come to within one inch of the floor plus one inch hem allowance and  $\frac{3}{4}$ -inch top turn-under. Machine-stitch the hem and slip-stitch top turn-under to cording placed around the lower edge of seat frame.

### RECASING AN INNERSPRING CUSHION

When chair or davenport cushions bulge in places or sag at the edges,

they should be opened and remade. You can recase the loose springs which have worn through their muslin or burlap coverings, or you can purchase the cloth-covered innerspring sections to fit average chairs or davenport.

**Supplies.** For an innerspring unit with 36 to 42 springs, you will need three to four yards of muslin or three to four feed sacks, No. 50 white thread for machine-stitching pocket strips, mattress twine, small curved needle.

If some of the old cotton is used for padding, you will need two yards of upholsterer's cotton for repairing. For all new padding five to six yards of upholsterer's cotton is necessary.

For a boxed muslin cover, plan on one and one-half to two yards of unbleached muslin or two feed sacks. You'll also need heavy-duty thread to match outside cover fabric.

**Measure and Remove Old Cover.** Measure and record length, width, and depth of cover. Open it, ripping lower edge at the back, then down six inches on each side. For a T-shaped cushion, rip across back, then six inches down on one side, and full length of other side.

Turn cover back and roll it off. Keep inside padding intact. If using cover again, brush and dry-clean or wash it. If springs are rusty, try rubbing them with powdered pumice mixed with boiled linseed oil. If rust does not come off, order new springs. Order springs, also, to replace any that are twisted.

**Repadding a Spring Unit.** Sometimes innerspring cushions become lumpy because padding has shifted. You will see if this has happened when you remove padding down to the spring unit. Make sure that springs are all strongly encased and firmly sewed together. Then place new moss or hair padding on top and bottom of the unit. Sew this padding to fabric covering springs with long stitches of mattress twine. Then wrap unit with cotton felt and replace in muslin casing, last in outer cover.



Fig. 19. (left) Measuring width of spring.

Fig. 20. (middle) Pocket measured and stitched.

Fig. 21. (right) First position of spring inserted in pocket.

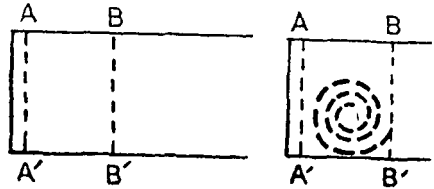
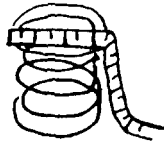

Make boxed cover of muslin like the original cover with exception of cording. Use measurements of original cover and add 1/2 inch for the seams. Cut a muslin piece for both top and bottom covering and a strip for the boxing. Pin boxing to seam line of top cover and start on a side five inches from back corner. Turn smooth corners without pleats or gathers in the boxing. Stitch boxing to top piece and snip at corners to within 1/8 inch of stitching. Crease sharply at each corner and pin creases to corners of bottom cover. Then pin, baste, and stitch boxing to bottom cover, leaving a six-inch opening down each side at the back.

**Make Pockets for Springs.** Usually bumps result from broken stitching twine and worn covering which tangles the springs. To correct, you should put springs into a new unit of muslin or burlap pockets.

Lay back a layer of padding to expose spring unit. Count and record number of rows of springs and number of springs per row. Remove one spring to work with and leave others in place until new pockets are made.

1. To figure width of strip for each row of pockets see figure 19.

|  |              |
|--|--------------|
| Height of a compressed spring          | 3 1/2 inches |
| Diameter of spring                     | 3 inches     |
| Seam allowance                         | 1/2 inch     |
| Total                                  | 7 inches     |
| Multiply total by 2 for width of strip | 14 inches    |

2. To figure length of pocket strip for each row of springs:

|   |                              |
|---|------------------------------|
| Measure diameter of spring                                    | 3 inches                     |
| Add 1/2 diameter of spring                                    | 1 1/2 inches                 |
| Each spring pocket requires                                   | 4 1/2 inches                 |
| Multiply by number of springs per row (using 6 as an example) | 6 x 4 1/2 inches = 27 inches |
| Add seam allowance  |                              |
| 2 x 1/2-inch seams  | = 1 inch                     |
| Total length of strip for each row                            | 28 inches                    |

Cut or tear as many strips of fabric of correct length and width as there are rows of springs. Fold each strip in half lengthwise and stitch a 1/2-inch seam at one end (figure 20, AA'). From this point measure off width of one pocket (figure 20, BB'). Measurement for width of a pocket is one half the distance around the spring. Start from seam at AA' and mark off this width for one pocket to BB'. Baste along these lines.

Test this pocket strip by compressing spring and slipping it sidewise to bottom of pocket (figure 21). Then pin pocket closed with seam allowance at top. Turn spring into an upright position to check size of pocket. Spring should stand 3 1/2 inches high when compressed easily and not be tight or loose in the pocket. If necessary, rework pocket measurements until spring fits properly.

Place and mark pins to indicate depth of top seam. Then remove pins and

Fig. 22. To test pocket strips, insert springs and pin them in place. Then work springs into an upright position.

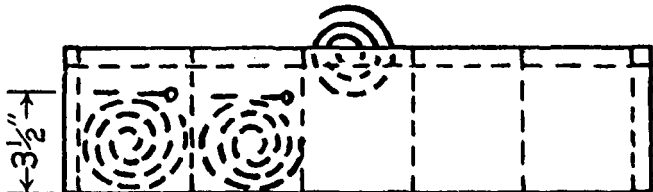

spring and use the AA' to BB' measurements as width for rest of pockets needed to encase springs for each row.

Machine-stitch side lines of pockets. Insert springs and pin above them as in figure 22. Stitch along marked seam line across top of strip. Then remove pins and turn springs upright with seam running through middle of the tops.

**Tie Pocket Rows Together.** Use your curved needle and mattress twine to fasten rows of encased springs together. Measure twine so it is  $1\frac{1}{2}$  times the length of each row. Start with a row of springs seam side up. Insert needle through cloth under top coil of first spring and tie a slip knot there (figure 23).

Carry thread across top of first spring, tying coils of the first and second springs where they come together. Continue tying top coils of springs until you reach end of row. There use a square knot to end tying. Tie each row the same way.

Place the tied rows of springs on table with seam side away from you. Use your curved needle and mattress twine again. Start with a slip knot at A and tie the first spring in row A to first spring in row B. Continue slip-tying rows across the unit. Wrap around each lengthwise twine in the center of each

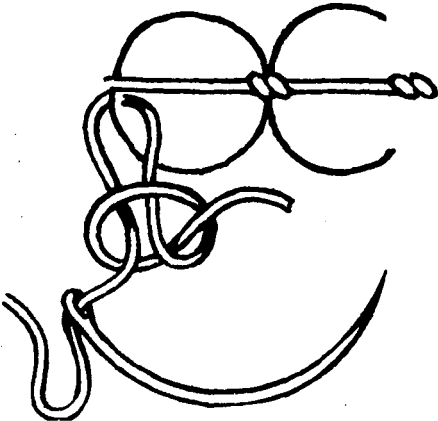

Fig. 23. Fasten rows of pocketed springs together, tying them on seam side of pockets first.

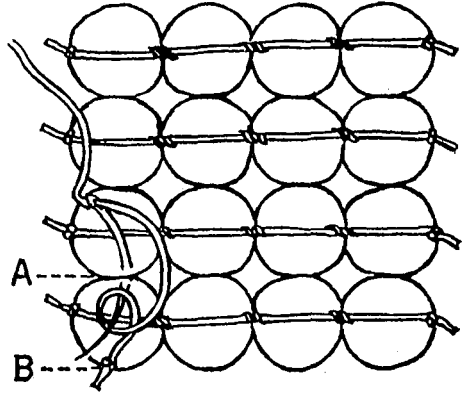

Fig. 24. Bottom rows of pocketed springs ready for second slip-tying.

spring as you come to it. End the row with a square knot. Turn unit over and tie other side the same way.

**Place Spring Unit In Cotton Padding.** If old cotton padding is usable, replace spring unit in its original position. Bring top padding into place over the unit. Work torn edges together as smoothly as possible. Sew through cotton at the sides and back with long diagonal stitches. Apply a thin layer of new cotton over top and bottom of unit and if necessary build out sides with cotton.

**To Rebuild Cushion With New Padding.** Padding in bad condition should not be used. Replace it with new cotton felt. Tear off four pieces the size of spring unit. Then tear two more pieces large enough to cover unit and extend over the four sides. Place one large

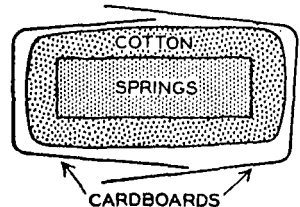

Fig. 25. Use cardboards to slip padded cushion into cover.

piece on the bottom and one on top, letting sides overlap. Lay cover on and see if padding will fill cover tightly. Add layers as needed. When testing you should not be able to feel springs with your hand.

**Insert Padded Unit in Cover.** Place unit with front edge away from you inside overlapped cardboards as in figure 25. Overlap cardboards on top and bottom of unit. Tie them in place. Then roll muslin or outside cover back, slipping it over front of the padded unit. Unroll cover, letting it come up over cardboards. Then cut string and carefully remove one cardboard at a time.

To square front corners and edges, slip a piece of cardboard (approximately 12 x 22 inches) between padded unit and cover.

If necessary to make front corners more firm, insert a roll of cotton. Take a piece 3 x 8 or 10 inches and roll it into a firm roll 3 inches wide and 3 to 4

inches in diameter. Slip a roll between cardboard and cover into each of front corners. Then remove cardboard.

**Complete Cushion Cover.** Draw open edges of cover together at back. Turn seam allowance under on boxing. Then pin edges together at corners, the center, and at 2-inch intervals.

Sew seam in muslin cover with a slip-stitch. Finish upholstery cover with a blind-stitch, using curved needle and heavy-duty thread which matches fabric.

**Note.** Some cushion springs are held together completely with wire. Cover such units with burlap large enough to cover top and bottom of unit and lap together over the sides. Stitch burlap on cushion edges to wire frame underneath. Pad with hair or moss and stitch this padding through burlap to top and bottom springs. Then pad with cotton, same as inner spring unit. Apply muslin casing and cover.



## STEPS FOR REUPHOLSTERING AT HOME—

|  | page |
|--|------|
| <b>Preparations</b> .....                                  | 2    |
| <b>Remove Old Upholstery</b> .....                         | 2    |
| <b>Repair and Refinish Before Reupholstering</b> .....     | 3    |
| <b>Tools and Materials</b> .....                           | 3    |
| <b>Procedure</b> .....                                     | 5    |
| <b>Measure and Estimate Webbing</b> .....                  | 5    |
| Fasten Webbing .....                                       | 5    |
| <b>Place the Springs</b> .....                             | 6    |
| Sew Springs to Webbing .....                               | 6    |
| Fasten Springs .....                                       | 7    |
| Tie Springs .....  | 8    |
| Cover Springs with Burlap .....                            | 10   |
| <b>Pad the Edges</b> .....                                 | 10   |
| <b>Now, the Main Padding</b> .....                         | 14   |
| Padding the Seat Section .....                             | 14   |
| Double Padding for the Seat Section .....                  | 15   |
| <b>Apply Fabric to Seat Section</b> .....                  | 15   |
| Muslin Cover for a Seat without a Separate Cushion .....   | 15   |
| Upholstery Fabric for a Seat without a Separate Cushion .. | 16   |
| Covering a Seat with Separate Cushion .....                | 16   |
| <b>Upholstering the Chair Back</b> .....                   | 17   |
| Chair Back without Springs, Frame Uncovered .....          | 17   |
| Chair Back without Springs, Frame Covered .....            | 18   |
| Chair Back with Springs .....                              | 19   |
| Boxed Strips as Part of Inside Back .....                  | 19   |
| Chair with a Tufted Back .....                             | 20   |
| <b>Upholstering the Arms</b> .....                         | 20   |
| Apply Webbing or Burlap Foundation .....                   | 20   |
| Pad the Arms .....   | 20   |
| Apply Muslin Cover to Inside Arm Piece .....               | 20   |
| Apply Muslin to Outside Arm .....                          | 22   |
| <b>Apply Muslin to Lower Front Seat Section</b> .....      | 22   |
| <b>Apply Muslin to Outside Back</b> .....                  | 22   |
| <b>Apply the Outside Cover</b> .....                       | 23   |
| <b>Recasing an Innerspring Cushion</b> .....               | 24   |

UNIVERSITY FARM, ST. PAUL 1, MINNESOTA

Cooperative Extension Work in Agriculture and Home Economics, University of Minnesota,  
Agricultural Extension Division and United States Department of Agriculture Cooperating,  
Paul E. Miller, Director. Published in furtherance of Agricultural Extension Acts of May 8  
and June 30, 1914.

20M-6-50