



Advanced LED Warning Signs for Rural Intersections Powered by Renewable Energy

Minnesota
Department of
Transportation

**RESEARCH
SERVICES**

Office of
Policy Analysis,
Research &
Innovation

Taek Mu Kwon, Principal Investigator
Department of Electrical and Computer Engineering
University of Minnesota Duluth

December 2010

Research Project
Final Report 2011-04



Your Destination... Our Priority



All agencies, departments, divisions and units that develop, use and/or purchase written materials for distribution to the public must ensure that each document contain a statement indicating that the information is available in alternative formats to individuals with disabilities upon request. Include the following statement on each document that is distributed:

To request this document in an alternative format, call Bruce Lattu at 651-366-4718 or 1-800-657-3774 (Greater Minnesota); 711 or 1-800-627-3529 (Minnesota Relay). You may also send an e-mail to bruce.lattu@state.mn.us. (Please request at least one week in advance).

Technical Report Documentation Page

1. Report No. MN/RC 2011-04	2.	3. Recipients Accession No.	
4. Title and Subtitle Advanced LED Warning Signs for Rural Intersections Powered by Renewable Energy		5. Report Date December 2010	
		6.	
7. Author(s) Taek Mu Kwon and Ryan Weidemann		8. Performing Organization Report No.	
9. Performing Organization Name and Address University of Minnesota Duluth Department of Electrical and Computer Engineering 1023 University Drive Duluth, MN 55812		10. Project/Task/Work Unit No. CTS Project #2008044	
		11. Contract (C) or Grant (G) No. (c) 89261 (wo) 91	
12. Sponsoring Organization Name and Address Minnesota Department of Transportation Research Services Section 395 John Ireland Boulevard, MS 330 St. Paul, Minnesota 55455		13. Type of Report and Period Covered Final Report	
		14. Sponsoring Agency Code	
15. Supplementary Notes http://www.lrrb.org/pdf/201104.pdf			
16. Abstract (Limit: 200 words) A majority of intersection-related fatal crashes occur at rural, through/stop intersections. At these intersections, sight restrictions caused by vertical and horizontal curves negatively affect a driver's ability to safely accept a gap in the traffic stream. Static advanced warning signs are sometimes installed at these intersections to warn drivers on the main, through approaches that an intersection is ahead. These warning signs appear to be ineffective. A new Advanced Light-Emitting Diode (LED) Warning System was developed and deployed at a rural, through/stop intersection with limited intersection sight distance due to a severe vertical curve. This warning system actively detects vehicles on all approaches and activates LED blinker warning signs for the conflicting movements. The research project included analysis of driver behavior obtained through video data and a survey of local residents and frequent users of the intersection. This report describes the development, implementation, and evaluation results of this new warning system.			
17. Document Analysis/Descriptors Warning signs, Light emitting diodes, Wireless LANs, Rural areas, Intersections		18. Availability Statement No restrictions. Document available from: National Technical Information Services, Springfield, Virginia 22161	
19. Security Class (this report) Unclassified	20. Security Class (this page) Unclassified	21. No. of Pages 101	22. Price

Advanced LED Warning Signs for Rural Intersections Powered by Renewable Energy

Final Report

Prepared by:

Taek Mu Kwon
Ryan Weidemann

Department of Electrical and Computer Engineering
University of Minnesota Duluth

December 2010

Published by:

Minnesota Department of Transportation
Research Services Section
395 John Ireland Boulevard, MS 330
St. Paul, Minnesota 55455

This report represents the results of research conducted by the authors and does not necessarily represent the views or policies of the Minnesota Department of Transportation or the University of Minnesota Duluth. This report does not contain a standard or specified technique.

The authors, the Minnesota Department of Transportation, and the University of Minnesota do not endorse products or manufacturers. Any trade or manufacturers' names that may appear herein do so solely because they are considered essential to this report.

Acknowledgements

This research was supported by the Local Road Research Board (LRRB). The authors would like to thank technical liaisons Brian Boder and Victor Lund of St. Louis County for their input on the design of the Advanced Light-Emitting Diode (LED) Warning System. We would also like to thank Kent Lunda and the staff of the St. Louis County Sign Shop for their help with the installation of the system, Mike Povolny of Povolny Specialties for building the digital video recorder (DVR) cabinet and mounting hardware, and Rocky Olson of Electric Builders Inc. for installing the on-site video monitoring system.

Table of Contents

Chapter 1: Introduction	1
Chapter 2: Hardware Design	3
2.1 System Design Goals.....	3
2.2 Hardware Design Preparation.....	3
2.2.1 Project Site and System Layout.....	3
2.2.2 Power Demand Estimates.....	6
2.2.2.1 PIR Detector	7
2.2.2.2 Radar Detector.....	8
2.2.2.3 Blinker Sign.....	8
2.2.3 Battery Bank Sizing	10
2.2.3.1 PIR Detector	10
2.2.3.2 Radar Detector.....	11
2.2.3.3 Blinker Signs	12
2.2.4 Charge Controllers	12
2.2.4.1 Morningstar SunSaver-20L Solar Charge Controller	12
2.2.4.2 Genasun GV-4 Solar Charge Controller.....	13
2.2.5 Weather Data Analysis.....	13
Chapter 3: Software Design	16
3.1 Introduction	16
3.2 Microcontroller.....	16
3.2.1 Programming the PIC16F690.....	16
3.2.2 HyperTerminal Interface	17
3.3 Wireless Transceivers.....	18
3.3.1 Detector and Blinker Configuration	19
3.4 Embedded Software.....	20
3.4.1 PIR Detector Protocols.....	21
3.4.2 Radar Detector Protocols	22
3.4.3 Blinker Sign S1 Protocols	23
3.4.4 Blinker Sign S2 and S3 Protocols	24
3.4.5 Alive Signals	25
Chapter 4: Testing	26
4.1 Introduction	26
4.2 Wireless Module Testing.....	26
4.3 Sensor Testing	28
4.3.1 PIR Sensor Testing.....	28
4.3.2 Ultrasonic Sensor Testing	29
4.3.3 Radar Sensor Testing	31
4.4 PCB Design and Testing	33
4.4.1 Blinker Sign PCB	33
4.4.2 PIR Detector PCB	35
4.4.3 Radar Detector PCB.....	37
Chapter 5: Installation	39
5.1 Detector Assembly	39
5.2 Blinker Assembly	42
5.3 On-Site Installation.....	43
5.3.1 Radar Detector Installation.....	43
5.3.2 PIR Detector Installation.....	46
5.3.3 Blinker Sign Installation.....	47

Chapter 6: Data Collection	49
6.1 On-Site Video Monitoring System	49
6.1.1 Video Layout.....	50
6.2 Speed Markers.....	51
6.3 Data Collection.....	51
6.3.1 Phase I Data.....	52
6.3.2 Phase II Data	52
6.4 Vehicle Speed Software Program.....	53
Chapter 7: Data Analysis	56
7.1 Major Approach Speed.....	56
7.2 Intersection Wait Times and Roll-Throughs	59
7.3 Mail-In Survey.....	60
7.4 On-Site Survey	63
Chapter 8: Conclusions and Future Recommendations	66
8.1 Conclusions	66
8.2 Future Recommendations	66
References.....	68
Appendix A : Charge Controller Installation Instructions	
Appendix B : Tapco Installation Instructions	
Appendix C : Z-Test Calculations	
Appendix D : Completed Mail-In Surveys	
Appendix E : Letter from Resident	
Appendix F : Mail-In Survey Comments	
Appendix G : On-Site Survey Comments	

List of Figures

Figure 1: Satellite view of the intersection [7].....	4
Figure 2: Original intersection layout.	5
Figure 3: Advanced LED warning system layout.....	6
Figure 4: PIR detector.....	7
Figure 5: Radar detector.....	8
Figure 6: Blinker sign.	10
Figure 7: Werker 6 V, 7.2 Ah (43.2 Wh) AGM lead-acid battery.....	11
Figure 8: Powerizer 11.1 V, 9.6 Ah (106.5 Wh) Li-ion battery.	12
Figure 9: Morningstar SunSaver-20L solar charge controller.	13
Figure 10: Genasun GV-4 solar charge controller.....	13
Figure 11: National average PV solar radiation July energy map [9].....	14
Figure 12: PIC16F690 pin diagram [14].....	17
Figure 13: MPLAB ICD 2 debugger and RJ-45 socket pin diagrams.	17
Figure 14: HyperTerminal interface output.	18
Figure 15: AC4790 detector (left) and blinker (right) transceiver settings.	19
Figure 16: API transmit packet format [13].....	20
Figure 17: API send data complete packet format [13].	20
Figure 18: PIR detector software flow diagram.....	21
Figure 19: Radar detector software flow diagram.	23
Figure 20: Blinker 1 software flow diagram.....	24
Figure 21: Blinker's 2 and 3 software flow diagram.	25
Figure 22: Testing of the AeroComm AC4790 SDK.	27
Figure 23: Detector (left) and blinker (right) wireless test modules.....	27
Figure 24: PIR sensor test circuit.....	29
Figure 25: SonaSwitch ultrasonic test circuit.	30
Figure 26: Banner R-Gage QT50RAF sensor.....	31
Figure 27: Radar sensor DIP switch configurations [15].....	32
Figure 28: Typical beam pattern of the R-Gage radar sensor [15].	33
Figure 29: Blinker sign PCB layout.....	34
Figure 30: Blinker sign 8-pin header.	34
Figure 31: Blinker sign relay PCB layout.....	35
Figure 32: PIR detector PCB layout.	36
Figure 33: PIR detector 10-pin header.....	37
Figure 34: Radar detector PCB layout.....	38
Figure 35: Radar detector 8-pin header.	38
Figure 36: PIR detector assembled solar panel housing.	39
Figure 37: Radar detector assembled solar panel housing.....	40
Figure 38: Solar panel mounting bracket (left) and attached solar panel housing (right).	41
Figure 39: Solar panel tilt angle [16].	42
Figure 40: Modified Tapco circuitry (left) and complete blinker sign.	42
Figure 41: Utility truck holding the first radar detector stop sign.	43
Figure 42: Mounted solar panel and radar sensor brackets.....	44
Figure 43: Adjusting the solar panel tilt angle.....	45
Figure 44: Installed radar detector.	45

Figure 45: Utility truck holding the PIR detector.	46
Figure 46: Installed PIR detector.	47
Figure 47: Installed “CROSS TRAFFIC WHEN FLASHING” blinker sign.....	48
Figure 48: Installed “VEHICLE APPROACHING WHEN FLASHING” blinker sign.	48
Figure 49: Video intersection layout.....	50
Figure 50: Images of a vehicle traveling towards (left) and through (right) the intersection.	51
Figure 51: On-site data collection.....	52
Figure 52: Supplied video viewer.	53
Figure 53: Vehicle speed GUI.	54
Figure 54: Black and white images of speed marker 1.....	55
Figure 55: Black and white images of speed marker 2.....	55
Figure 56: Vehicle speed distribution before installation.	57
Figure 57: Vehicle speed distribution after installation.....	57
Figure 58: Mail-in survey.	61

List of Tables

Table 1: Power Consumption of ALWS Components.....	6
Table 2: Carmanah CTI-11 Solar Panel [10]	14
Table 3: BP SX320J Solar Panel [11].....	15
Table 4: Solar Panel Characteristics [12].....	15
Table 5: PIC16F690 Characteristics	16
Table 6: Wireless Peer-to-Peer Communications Channels	18
Table 7: Recommended Solar Panel Tilt Angles for Fixed Systems [16]	41
Table 8: Comparison of Average Speeds Before and After Installation	58
Table 9: Comparisons of No Conflict and Conflict Average Speeds After Installation.....	59
Table 10: Comparisons of Average Intersection Wait Time and Total Roll-Throughs Before and After Installation	60
Table 11: Comparisons of No Conflict and Conflict Average Wait Time and Total Roll-Throughs After Installation.....	60
Table 12: Mail-In Survey Results	62
Table 13: On-Site Survey Results.....	64

Executive Summary

In Minnesota, 70 percent of all intersection-related fatal crashes for the period of 2006 to 2008 occurred at rural, through/stop intersections [1]. The Minnesota Department of Transportation identified improving the design and operation of intersections as a critical emphasis area in the Minnesota Comprehensive Highway Safety Plan [2]. At these intersections, sight restrictions caused by vertical and horizontal curves negatively affect a driver's ability to safely accept a gap in the traffic stream.

This report presents the results of a two-year study on the development and evaluation of a new intersection warning system referred to as an Advanced Light-Emitting Diode (LED) Warning System (ALWS). The ALWS was developed to replace the static warning signs that are commonly used to address the sight restrictions at rural through/stop intersections, which have been shown to be ineffective [3-5]. The ALWS consists of vehicle detectors that detect approaching or stopped vehicles and LED warning signs that blink according to the received messages from the detectors. For easy installation, all signs and detectors are powered by solar panels and rechargeable batteries. All message communications between the detectors and warning signs are performed through wireless transceivers. Wireless communication avoids potential problems associated with buried wires, i.e., wire breakages, short circuits, difficulty of replacement, and monthly power bills.

In order to evaluate this new sign technology, the intersection of West Tischer Road and Eagle Lake Road in Duluth, Minnesota was chosen. West Tischer Road is the main road with a through condition while Eagle Lake Road is the minor road with a stop condition. The Annual Average Daily Traffic (AADT) for West Tischer Road is 980 vehicles per day. The AADT for Eagle Lake Road is 550 vehicles per day. The number of daily entering vehicles is 760 vehicles per day [6]. This intersection was selected because of a severe vertical curve on the east approach of West Tischer Road. This vertical curve significantly reduces the available intersection sight distance for vehicles stopped on either the north or south approaches of Eagle Lake Road thereby requiring these vehicles to blindly accept gaps in the westbound traffic stream. Conversely, vehicles traveling westbound on West Tischer Road cannot see cross traffic at the intersection until they are nearly in the intersection.

The ALWS for this intersection consists of three blinker signs and four vehicle detectors. The blinker sign for the main approach displays the message "CROSS TRAFFIC WHEN FLASHING" for westbound traffic. There are two radar detectors on Eagle Lake Road installed on the top of the stop signs. These detectors detect vehicles stopped at the stop signs. When a vehicle is detected at either stop sign, a wireless signal is transmitted to the blinker sign and it flashes. The blinker signs for the minor approaches displays the message "VEHICLE APPROACHING WHEN FLASHING" for northbound or southbound traffic. These signs were installed on the northeast and southwest quadrants of the intersection. Two Passive Infrared (PIR) detectors are located on West Tischer Road. One detector is located east of the intersection and detects vehicles traveling westbound on West Tischer Road. The other detector is located west of the intersection and detects vehicles traveling eastbound on West Tischer Road. When a vehicle is detected by either PIR sensor, a wireless signal is transmitted to both blinker signs and they flash. These blinker signs provide an advanced warning to vehicles stopped at either stop sign that a vehicle is approaching the intersection from the east or west on West Tischer Road.

Video data was collected through an on-site video monitoring system consisting of a digital video recorder (DVR) and two video cameras. The first camera records video of vehicles

traveling toward the intersection through the vertical curve. The second camera records vehicles traveling through the intersection. Video data collection occurred in two phases: before (Phase I) and after (Phase II) the installation of the ALWS. Phase I data was collected for a time period of 48 days and Phase II data for 204 days. Speed markers were painted on the roadway to measure the speed of vehicles with 1 mph accuracy. Analysis of the video data before and after the installation of the ALWS included vehicle speeds on the main approach, intersection wait time, and intersection roll-throughs. In addition to the analysis of the video data, mail-in and on-site surveys were conducted. The findings based on the video data analysis are summarized below.

- The average vehicle speed on the main approach decreased during the nighttime after installation of the ALWS while no changes were observed during the daytime.
- When a vehicle enters the intersection from the minor approach, the average speed on the main approach decreased after installation of the ALWS.
- The average intersection wait time from the minor approach was significantly increased (5.4 seconds) when the warning signs were flashing.
- Number of intersection roll-throughs decreased to zero when the warning signs on the minor approaches were flashing.
- Number of intersection roll-throughs increased when the warning signs in the minor approach were not flashing.

Overall, the ALWS was effective at reducing vehicle speeds on the main approach, and increasing the wait time and altogether stopping roll-throughs for vehicles on the minor approaches when a conflict exists at the intersection. However, an increase in roll-throughs when no conflict exists at the intersection is a concern that must be addressed in the future design of the ALWS. According to the mail-in and on-site survey results, 86 percent of respondents believed that the warning system is effective. However, they also raised a concern that the drivers might start ignoring the stop signs and/or not look for oncoming traffic, thus completely relying on the warning signs. This is a cause for concern if the electronics in the warning system fail. If these concerns are addressed, the researchers believe that the ALWS can be an effective system for reducing crashes in rural stop/through intersections.

Chapter 1: Introduction

In Minnesota, 70 percent of all intersection-related fatal crashes for the period of 2006 to 2008 occurred at rural, through/stop intersections [1]. The Minnesota Department of Transportation identified improving the design and operation of intersections as a critical emphasis area in the Minnesota Comprehensive Highway Safety Plan [2].

Rural crashes are generally more severe than urban crashes due to factors such as speed, and availability and responsiveness of emergency services. Right-angle crashes account for the largest percentage of crashes at rural, through/stop intersections in Minnesota [1]. At these intersections, sight restrictions caused by vertical and horizontal curves negatively affect a driver's ability to safely accept a gap in the traffic stream. Static advanced warning signs are sometimes installed at these intersections to warn drivers on the main, through approaches that an intersection is ahead. These warning signs appear to be ineffective at improving safety [3-5]. Various intersection countermeasures such as realigning intersection approaches, correcting approach grades, clearing sight triangles, and even installing roundabouts have been shown to be effective at improving intersection safety performance. However, these countermeasures are expensive and cannot be readily justified at low-volume, rural intersections, especially for local road authorities such as counties and townships with limited budgets.

As a potential low-cost countermeasure to rural, through/stop intersection crashes, this research report presents the development, installation, and analysis of an Advanced Light-Emitting Diode (LED) Warning System (ALWS) completed over two years. This system was developed for rural, high speed, through/stop intersections with significantly limited intersection sight distance due to vertical or horizontal curves. For this warning system, three key technologies were utilized. First, the system is powered entirely by renewable energy through the use of photovoltaic panels (solar panels). Therefore, a connection to a local electric power grid is not required. Second, this system is composed of LEDs and non-intrusive vehicle sensors that efficiently use electrical power. Traffic signs with LEDs on the perimeter of the sign panel, commonly referred to as blinker signs, are approved by the Federal Highway Administration (FHWA) and have been deployed in Minnesota for other applications. And third, all communication between vehicle detectors and blinker signs are transmitted wirelessly. Wireless communication increases mobility of the system while eliminating the potential of short/open circuit problems associated with buried wires. These three technologies support a low-cost, easy-to-install ALWS.

Development of the ALWS includes hardware and software design, and testing. In Chapter 2, a step-by-step hardware design procedure is described. First, a project location is selected. Next, the power consumption of each selected part in the ALWS is estimated and used to calculate the capacity of each component's rechargeable battery bank. Solar radiation, which is highly dependent on location, must be carefully analyzed using available solar radiation maps. Finally, the estimate of the seasonal solar radiation and the expected daily power consumption of each component can be used to select a solar panel. Chapter 3 summarizes the configuration of each wireless transceiver as well as the software protocols used in each ALWS component. Part selection and testing of wireless transceivers, vehicle sensors, and PCBs, outlined in Chapter 4, is crucial in order to achieve a reliable, low-cost, low-power warning system.

Installation of the ALWS, discussed in Chapter 5, begins in lab with the assembly of vehicle detectors and blinker signs. Parts for each vehicle detector are mounted inside a weatherproof solar panel housing unit. Blinker signs are rewired to accommodate the wireless

transceivers and blinker control circuitry. With the help from members of the St. Louis County Sign Shop, the on-site installation took one full day. Vehicle detectors were installed on u-channel sign posts by mounting the solar panel housing units to an adjustable mounting bracket. Blinker signs were installed on u-channel support systems.

Analysis of the effectiveness of the ALWS focused on observations of video data and survey results. Video data collection was completed before and after the installation of the ALWS using an on-site video monitoring system discussed in Chapter 6. Two video cameras recorded vehicles traveling towards the intersection in the vertical blind and vehicles traveling through the intersection. Speed markers were painted on the roadway and a vehicle speed software program was developed to measure vehicle speed with 1 mph (1.6 km/h) accuracy. Analysis of the collected video data included three vehicle movements: vehicle speed, intersection wait time, and intersection roll-throughs. These vehicle movements were compared before and after the installation of the ALWS and when the warning system was activated or not. A mail-in survey was sent to residents living within a half-mile radius of the intersection. Also, an on-site survey was conducted at the intersection. Results from both surveys are summarized and discussed. Analysis of the video data and survey results can be found in Chapter 7. Finally, Chapter 8 finishes the report with concluding remarks along with future recommendations.

Chapter 2: Hardware Design

2.1 System Design Goals

The design objective is to develop a self-sufficient LED warning system powered by renewable energy. Each component of the ALWS system stores electric power whenever solar radiation is available. Power is stored in a battery bank which is sized to retain 50 percent of its full capacity after seven days of continuous power supply without charging.

2.2 Hardware Design Preparation

Before the actual design of the ALWS can begin the power demand of each component and the average solar availability at the location of the warning system must be analyzed and estimated.

2.2.1 Project Site and System Layout

The site chosen for the installation of the ALWS was at the intersection of West Tischer Road and Eagle Lake Road in Duluth, Minnesota. West Tischer Road is the main road with a through condition while Eagle Lake Road is the minor road with a stop condition. The speed limit on the west leg of West Tischer Road is 45 mph (72.4 km/h). The east leg of West Tischer Road and both legs of Eagle Lake Road have a statutory speed limit with a maximum speed of 55 mph (88.5 km/h). The Annual Average Daily Traffic (AADT) for West Tischer Road is 980 vehicles per day. The AADT for Eagle Lake Road is 550 vehicles per day. The number of daily entering vehicles is 760 vehicles per day [6]. This intersection was selected because of a severe vertical curve on the east approach of West Tischer Road. This vertical curve significantly reduces the available intersection sight distance for vehicles stopped on either the north or south approaches of Eagle Lake Road thereby requiring these vehicles to blindly accept gaps in the westbound traffic stream. Conversely, vehicles traveling westbound on West Tischer Road cannot see cross traffic at the intersection until they are nearly in the intersection. Figure 1 shows a satellite view of the chosen intersection.

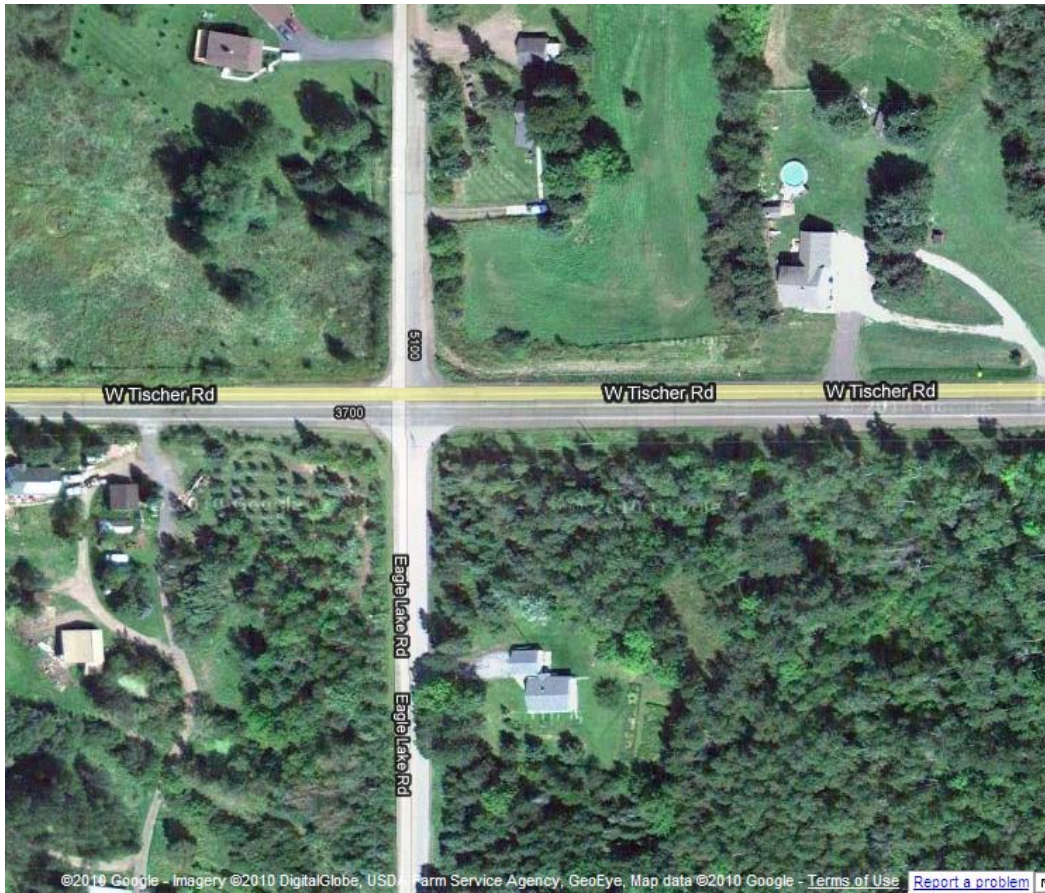

Figure 1: Satellite view of the intersection [7].

The original intersection layout had three signs warning vehicles traveling westbound on West Tischer Road that there was limited visibility due to the vertical curve. Figure 2 shows the original layout of these warning signs. The first set of signs was located 520 ft (158.5 m) from the intersection. These two signs displayed the message “BLIND INTERSECTION AHEAD 35 MPH”. The next sign was located 445 ft (135.6 m) from the intersection and displayed the message “SPEED LIMIT 45 MPH”. The dimensions of both signs are 36 in (91.4 cm).

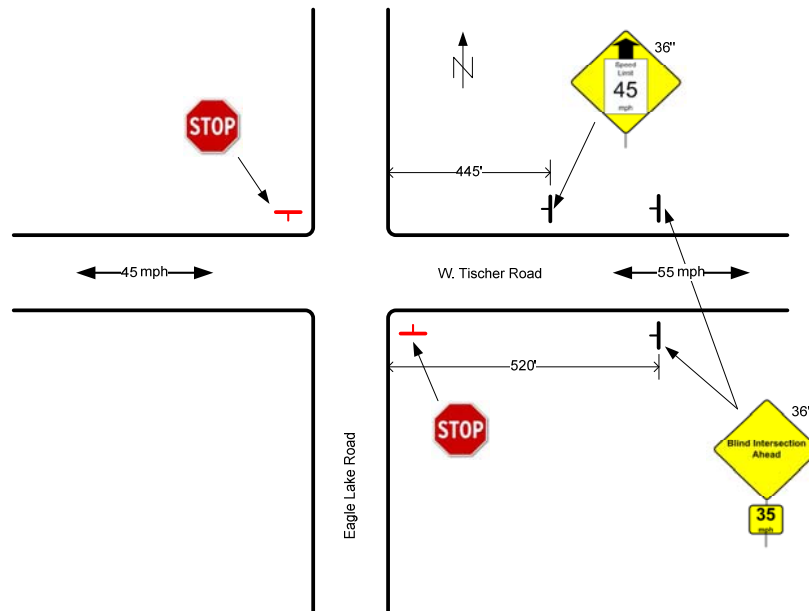

Figure 2: Original intersection layout.

The layout for the ALWS is shown in Figure 3. The ALWS for this intersection consists of three blinker signs and four vehicle detectors. The blinker sign for the main approach, S1, displays the message “CROSS TRAFFIC WHEN FLASHING” for westbound traffic. The sign dimension is 48 in (121.9 cm) and is located 525 ft (160.0 m) east of the intersection. There are two radar detectors on Eagle Lake Road installed on the top of the two stop signs located on the northwest and southeast quadrants of the intersection. These detectors, D2 and D3, detect vehicles stopped at the stop signs. When a vehicle is detected at either stop sign, a wireless signal is transmitted to S1 and it flashes. The activation of S1 warns vehicles traveling westbound on West Tischer Road that there is cross traffic detected at the intersection ahead. The flash time for S1 is based upon the time a vehicle is detected and present in a detection zone at either stop sign and is therefore variable in length.

The blinker signs for the minor approaches, S2 and S3, displays the message “VEHICLE APPROACHING WHEN FLASHING” for northbound or southbound traffic. These signs were installed on the northeast and southwest quadrants of the intersection. The dimensions for both signs are 36 in (91.4 cm). Two Passive Infrared (PIR) detectors, D1 and D4, are located on West Tischer Road. Detector D1 is located 645 ft (196.6 m) east of the intersection and detects only vehicles traveling westbound on West Tischer Road. Detector D4 is located 460 ft (140.2 m) west of the intersection and detects only vehicles traveling eastbound on West Tischer Road. When a vehicle is detected by either PIR sensor, a wireless signal is transmitted to S2 and S3 and they both flash for a fixed time period of 10 seconds. The flash time S2 and S3 was calculated as the expected time for a westbound vehicle traveling at the posted speed limit to arrive at the intersection. This was considered the critical movement. Signs S2 and S3 provide a warning to vehicles stopped at either stop sign that a vehicle was detected approaching the intersection from the east or west on West Tischer Road.

The “BLIND INTERSECTION AHEAD” signs from the original intersection layout were removed but the “SPEED LIMIT 45 MPH” warning sign was left in its original place.

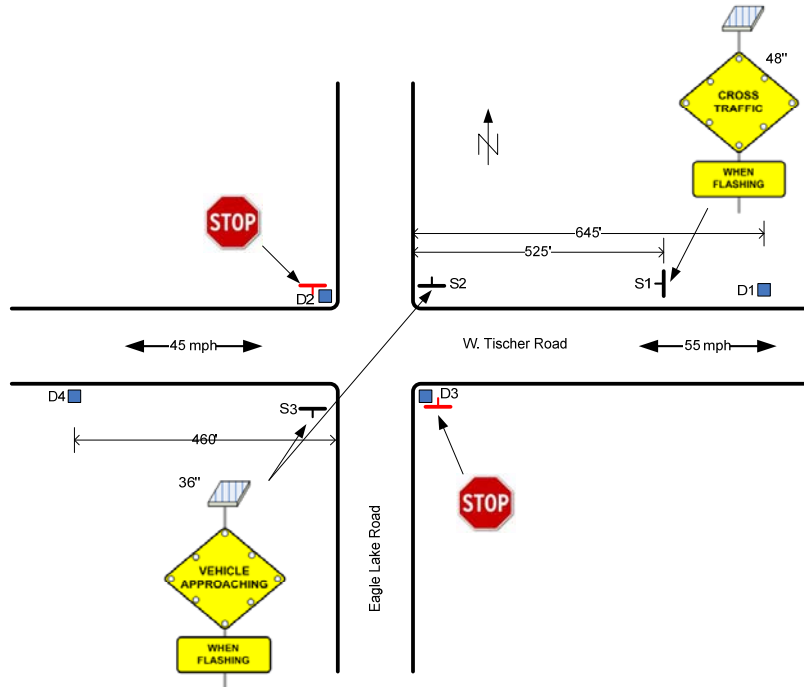

Figure 3: Advanced LED warning system layout.

2.2.2 Power Demand Estimates

The second step in the design of the ALWS is to calculate the expected power demand of each component in the warning system. Table 1 summarizes the power consumption of key parts of each component in the warning system.

Table 1: Power Consumption of ALWS Components

Component	Idle State		Active State	
	Current Draw	Power	Current Draw	Power
PIR Sensor	170 μ A (5.0 V)	0.85 mW	170 μ A (5.0V)	0.85 mW
Radar Sensor	76 mA (12.0 V)	912 mW	85 mA (12.0V)	1.02 W
Wireless Transmitter	29 mA (6.0 V)	174 mW	130 mA (6.0V)	510 mW
Wireless Receiver	29 mA (6.0 V)	174 mW	29 mA (6.0V)	174 mW
Lead-Acid Charge Controller	0.125 mA (17.0 V)	2.0 mW	0.125 mA (17.0V)	2.0 mW
Li-Ion Charge Controller	0.125 mA (17.0 V)	2.0 mW	0.125 mA (17.0V)	2.0 mW
Tapco BlinkerSign®	16 mA (4.8 V)	77 mW	340 mA (4.8V)	1.56 W

The active state current draw of each component is when it is detecting (PIR or radar sensor), transmitting or receiving (wireless), or blinking (Traffic and Parking Control Co., Inc. (Tapco) BlinkerSign®). The idle state current draw is when each component is not active.

2.2.2.1 PIR Detector

There are two PIR detectors located on West Tischer Road in the ALWS. Each detector consists of a PIR sensor for detecting vehicles, a transmitting wireless module, and a Lead-Acid battery charge controller. Using the power consumption values in Table 1, the estimated power consumption of a PIR detector is:

$$0.85 \text{ mW} + 174.0 \text{ mW} + 2.0 \text{ mW} = 176.9 \text{ mW} \quad (1)$$

To calculate average daily watt hours (Wh) the total watts must be multiplied by 24 hours. The estimated daily power consumption of the PIR detector is:

$$176.9 \text{ mW} \times 24 \text{ hours} = 4.25 \text{ Wh} \quad (2)$$

In Eq. (1), the wireless transmitter idle state power consumption (174 mW) was used instead of the much larger active state power consumption (510 mW). The PIR detector only transmits when a vehicle is detected, otherwise it is idle. The Annual Average Daily Traffic (AADT) count for West Tischer Road is 980 vehicles [6] and the wireless transmitter takes a maximum of 100 ms to send one packet of data. When vehicle detection occurs, only one data packet is sent. Even when assuming a 100 percent vehicle detection rate, since the AADT count for West Tischer Road is so low and the time to transmit one data packet is so short, the power consumption added during wireless transmission is negligible. Figure 4 displays a diagram of a PIR detector configuration.

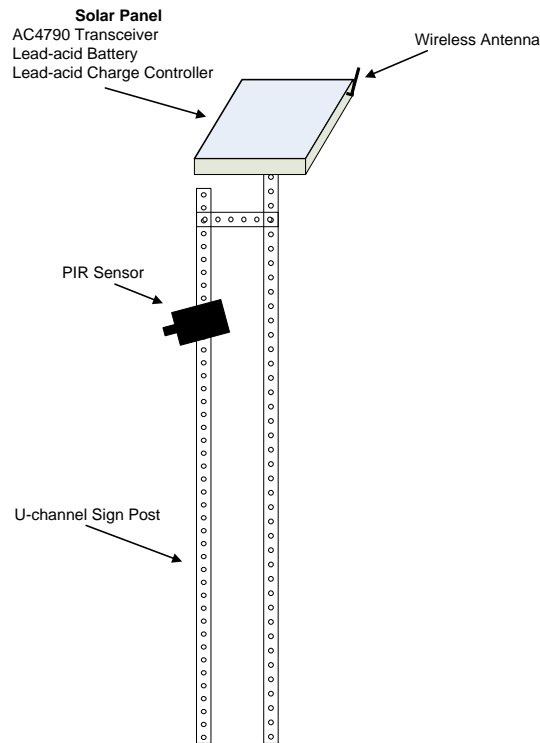

Figure 4: PIR detector.

2.2.2.2 Radar Detector

There are two radar detectors located at either stop sign on Eagle Lake Road in the ALWS. Each detector consists of a radar sensor for detecting vehicles, a transmitting wireless module, and a Li-ion battery charge controller. Figure 5 shows a diagram of radar detector implementation. Using the power consumption values in Table 1, the estimated power consumption and daily power consumption of a radar detector is:

$$912.0 \text{ mW} + 174.0 \text{ mW} + 2.0 \text{ mW} = 1.09 \text{ W} \quad (5)$$

$$1.09 \text{ W} \times 24 \text{ hours} = 26.16 \text{ Wh} \quad (6)$$

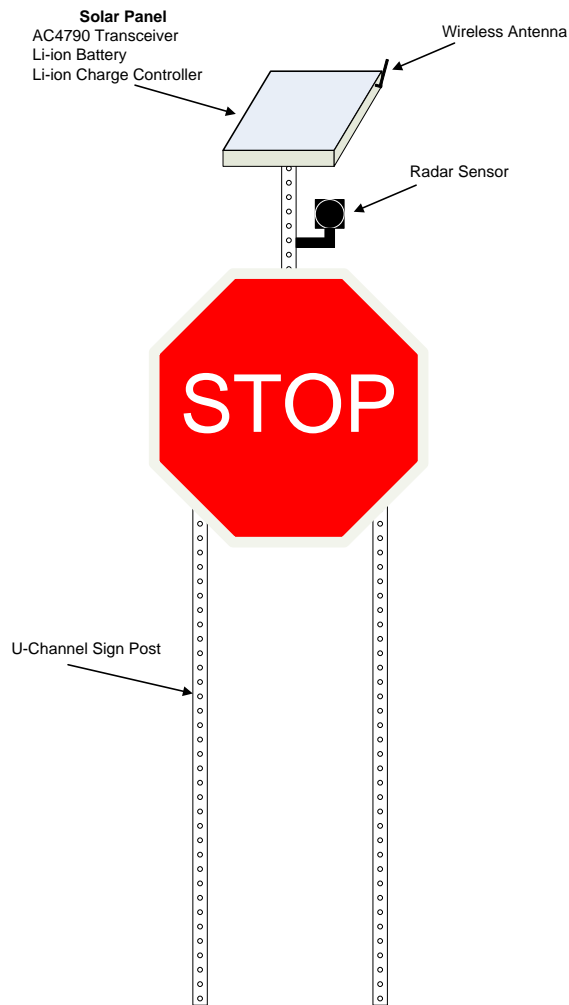

Figure 5: Radar detector.

2.2.2.3 Blinker Sign

There are three blinker signs in the ALWS. Two blinker signs are located at the NE and SW corners of the intersection of Eagle Lake Road and West Tischer Road. The third blinker

sign is located east of the intersection on the north side of West Tischer Road. The blinker signs (Figure 6) are the previously purchased BlinkerSigns® manufactured by Tapco. These signs come preinstalled with eight high-power LEDs spread around the perimeter of the sign and include Day-Viz™ circuitry which comes pre-packaged with Ni-MH batteries, a charging circuit, and a solar panel. In addition, the Tapco BlinkerSigns® are modified to contain a receiving wireless module. Using the power consumption values in Table 1, the estimated power consumption and daily power consumption of an idle blinker sign is:

$$77.0 \text{ mW} + 174.0 \text{ mW} = 251.0 \text{ mW} \quad (7)$$

$$251.0 \text{ mW} \times 24 \text{ hours} = 6.02 \text{ Wh} \quad (8)$$

Notice in Eq. (7) that the idle state power consumption (77 mW) of a blinker sign is used and not the active state power consumption (340 mW). To accurately calculate the expected power consumption of each component, the highest power consumption values must be incorporated into the calculation. In their active state, blinker signs flash for 10 seconds (0.5 seconds on, 0.5 seconds off) only when a vehicle is detected. Using the larger AADT value of 980 for West Tischer Road [6] and an “ON” blink time of 5 seconds, a blinker sign will blink for:

$$980 \text{ AADT} \times 5 \text{ seconds} = 4,900 \text{ seconds} = 81.7 \text{ minutes} = 0.057 \text{ days} \quad (9)$$

Assuming a 100 percent vehicle detection rate, a blinker sign will blink for 0.057 days according to Eq. (9). Using this value and the active state power consumption value in Table 1 for a Tapco BlinkerSign® (1.56 W), the estimated power consumption of an active blinker sign is:

$$1.56 \text{ W} \times 0.057 \text{ days} = 0.09 \text{ Wh} \quad (10)$$

The estimated daily power consumption of an active blinker sign is:

$$0.09 \text{ Wh} \times 24 \text{ hours} = 2.16 \text{ Wh} \quad (11)$$

Adding the daily power consumption for a blinker sign in its idle state (Eq. (8)) to the daily power consumption of a blinker sign in its active state (Eq. (11)) the total daily power consumption of a blinker sign is:

$$6.02 \text{ Wh} + 2.16 \text{ Wh} = 8.18 \text{ Wh} \quad (12)$$

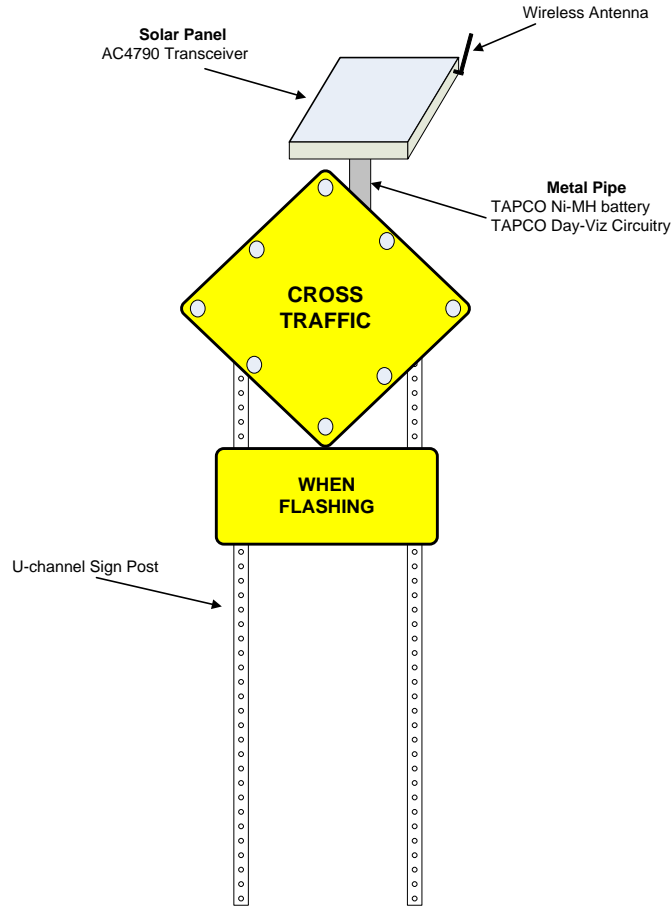

Figure 6: Blinker sign.

The results of Eq. (2), (6), and (12) are estimates of the daily power consumption for all three components of the ALWS. These estimates are used to size the batteries (Lead-acid or Li-ion) and the solar panels.

2.2.3 Battery Bank Sizing

For this system design, 7-day continuous power supply is used as the battery storage requirement. A storage capacity longer than seven days may increase the cost without providing much benefit, since no solar energy for seven consecutive days rarely occurs.

2.2.3.1 PIR Detector

Since the battery bank of each component in the system must be supported by a 7-day continuous power supply, the 7-day power supply requirement for a PIR detector is:

$$4.25 \text{ Wh} \times 7 \text{ days} = 29.75 \text{ Wh} \quad (13)$$

The PIR detector is powered by Absorbed Glass Mat (AGM) lead-acid batteries (Figure 7). Typically, AGM batteries allow around 400 cycles of 100 percent discharges in its lifetime. Although AGM lead-acid plates are designed thicker for a longer lifespan, the plates tend to wear out when more than 50 percent of the battery capacity is discharged. To insure a long battery life, a limit of 50 percent discharge level is used for this design. This would extend the AGM battery lifetime to many years. Adding this limit to the energy requirement gives:

$$29.75 \text{ Wh} / 0.50 = 59.5 \text{ Wh} \quad (14)$$

The battery selected to support the PIR detector is the Werker 6 V, 7.2 Ah (43.2 Wh) AGM lead-acid battery (Figure 7). This battery is available at Batteries Plus for \$19.79. The dimensions of this battery are 6.0" x 3.75" x 1.25" and it weighs 2.8 lbs. In order to support the 7-day power supply requirement with low voltage protection, two batteries are needed. These two batteries are connected in series to produce 12 V, 7.2 Ah equaling 86.4 Wh.



Figure 7: Werker 6 V, 7.2 Ah (43.2 Wh) AGM lead-acid battery.

2.2.3.2 Radar Detector

The 7-day power supply requirement and low voltage protection for a radar detector is:

$$26.16 \text{ Wh} \times 7 \text{ days} = 183.1 \text{ Wh} \quad (15)$$

$$183.1 \text{ Wh} / 0.50 = 366.2 \text{ Wh} \quad (16)$$

Since a radar detector uses six times as much power as a PIR detector, a larger capacity battery is used. A radar detector is powered by Li-ion batteries. The Li-ion battery pack selected to power a radar detector is an 11.1 V, 9.6 Ah (106.5 Wh) battery (Figure 8). In order to support the 7-day power supply requirement with low voltage protection, two batteries are needed. These two batteries are connected in parallel to produce 11.1V, 19.2 Ah equaling 213.1 Wh. This is sufficient to supply power for the 7-day power supply requirement but not sufficient for low voltage protection.



Figure 8: Powerizer 11.1 V, 9.6 Ah (106.5 Wh) Li-ion battery.

2.2.3.3 Blinker Signs

Referring to the Tapco BlinkerSign® data sheet [8], the BlinkerSign® uses a Ni-MH battery bank with a capacity of 14,000 mAh. Converting this to Wh yields:

$$14,000 \text{ mAh @ } 4.8 \text{ V} = 67,200 \text{ mWh} = 67.2 \text{ Wh} \quad (17)$$

The estimated power consumption of a blinker sign is 8.18 Wh. Using the same 7-day power supply requirement as the previous components:

$$8.18 \text{ Wh} \times 7 \text{ days} = 57.2 \text{ Wh} \quad (18)$$

Using the Tapco battery bank, the 7-day power supply requirement can be met.

2.2.4 Charge Controllers

There are two types of charge controllers that are used in this project. One charge controller is used with Li-ion batteries and the other is used with lead-acid batteries. Charge controller installation instructions can be found in Appendix A.

2.2.4.1 Morningstar SunSaver-20L Solar Charge Controller

This charge controller is used for charging AGM sealed lead-acid batteries. The SunSaver-20 uses an advanced series Pulse Width Modulation (PWM) charge control for constant voltage battery charging. A sensor next to the green LED measures ambient temperature conditions. The SunSaver-20L is rated for 12 V systems. The maximum solar array open circuit voltage is 25 V. The maximum short circuit current rating for the SunSaver-20 is 25 A. The operating power consumption is 10 mA. Use of copper wires between 10 AWG and 14 AWG are

recommended. The Low Voltage Disconnect (LVD) is set at 11.5 V and the LVD reconnect is set at 12.6 V.



Figure 9: Morningstar SunSaver-20L solar charge controller.

2.2.4.2 Genasun GV-4 Solar Charge Controller

This charge controller is used for charging Li-ion batteries. GV-4 uses Maximum Power Point Tracking (MPPT) for charging. The GV-4 is rated for a 12 V battery up to 45 W. The maximum load current is 4 A. The solar panel open circuit voltage must be between 0–27 V. The operating power consumption is 0.125 mA. Cooper wire between 12 AWG and 24 AWG are recommended. The Genasun GV-4 has LVD set at 7.2 V.



Figure 10: Genasun GV-4 solar charge controller

2.2.5 Weather Data Analysis

Availability of solar energy in terms of potential convertible energy is highly dependent on location, and studying the expected annual availability is extremely important and should be the first step before the actual system design. For the solar energy, the National Renewable Energy Lab (NREL) [9] provides an excellent resource.

For the solar radiation energy, NREL provides monthly breakdowns which should be used as an expected availability of solar energy source. The map in Figure 11 shows 2004 national solar radiation for flat plate, solar panels facing south for the month of July (representing summer). According to the July map, Duluth, MN provides 5.5-6.0 kWh/m²/day. Similarly, solar radiation can be found for the other three seasons: fall, winter, and spring by using solar radiation maps from the same source. According to the October map (representing

fall), Duluth, MN provides 3.5-4.0 kWh/m²/day. During January, (representing winter) the location provides 2.5-3.0 kWh/m²/day. Finally, the April map (representing spring) indicates that the location provides 5.0-5.5 kWh/m²/day. These numbers are used in the system design to estimate the amount of energy that could be generated by solar radiation.

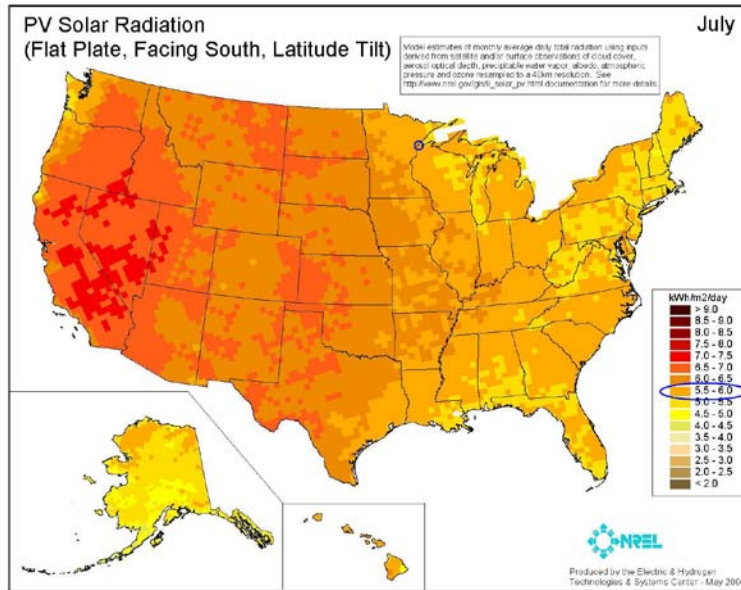

Figure 11: National average PV solar radiation July energy map [9].

The solar panel selected to power the PIR detectors is the Carmanah CTI-11. Its specifications are summarized in Table 2.

Table 2: Carmanah CTI-11 Solar Panel [10]

Model	Power	Open Circuit Voltage	Short Circuit Current	Peak Voltage	Peak Current	Weight	Dimensions
Carmanah CTI-11	11 W	22.0 V	0.65 A	17.4 V	0.63 A	3.5 lbs	14.0 in x 15.0 in x 2.0 in

The unit kWh/m²/day is essentially equivalent to "hours of full noontime sun per day". To calculate an estimate of the expected Average Daily Productive Power (ADPP) of a solar panel, the following equation is used:

$$ADDP \text{ (Wh)} = \text{solar panel power (kW)} \times \text{kWh/m}^2/\text{day} \times \text{efficiency factor} \times 1000 \quad (19)$$

The efficiency factor is used to allow for unavoidable system inefficiencies. Although the solar panel in this case is rated at 11.0 W as its maximum power, the maximum power is only attainable under solar radiation of a full sun near the equator. In Minnesota, maximum convertible power of an 11.0 W solar panel is about 8.25 W under the full sun, which is 75 percent. This estimation is based on actual monitoring of the solar panel. As a result, the

efficiency factor is 75 percent. The expected ADPP of the Carmanah CTI-11 solar panel for each season is estimated as:

$$0.011 \text{ kW} \times 5.25 \text{ kWh/m}^2/\text{day} \times 0.75 = 43.3 \text{ Wh for spring} \quad (20)$$

$$0.011 \text{ kW} \times 5.75 \text{ kWh/m}^2/\text{day} \times 0.75 = 47.4 \text{ Wh for summer} \quad (21)$$

$$0.011 \text{ kW} \times 3.75 \text{ kWh/m}^2/\text{day} \times 0.75 = 30.9 \text{ Wh for fall} \quad (22)$$

$$0.011 \text{ kW} \times 2.75 \text{ kWh/m}^2/\text{day} \times 0.75 = 22.7 \text{ Wh for winter} \quad (23)$$

Since a PIR detector requires around 4.25 Wh per day, the selected solar panel is sufficient to supply enough power year round.

The two radar detectors require a much high battery capacity to support the electronics so a larger solar panel is needed. The estimated power consumption of a radar detector is 26.16 Wh. The solar panel selected for the radar detector is the BP Solar SX320J. Its specifications are summarized in Table 3.

Table 3: BP SX320J Solar Panel [11]

Model	Power	Open Circuit Voltage	Short Circuit Current	Peak Voltage	Peak Current	Weight	Dimensions
BP Solar SX320J	20 W	21.0 V	1.29 A	16.8 V	1.19 A	5.5 lbs	16.7 in x 19.7 in x 2.0 in

In Minnesota, the maximum convertible power of the 20.0 W PV is about 15.0 W under the full sun, which is 75 percent. Using the above equations, the expected ADPP of the solar panel for each season is estimated as:

$$0.02 \text{ kW} \times 5.25 \text{ kWh/m}^2/\text{day} \times 0.75 = 78.8 \text{ Wh for spring} \quad (24)$$

$$0.02 \text{ kW} \times 5.75 \text{ kWh/m}^2/\text{day} \times 0.75 = 86.3 \text{ Wh for summer} \quad (25)$$

$$0.02 \text{ kW} \times 3.75 \text{ kWh/m}^2/\text{day} \times 0.75 = 56.3 \text{ Wh for fall} \quad (26)$$

$$0.02 \text{ kW} \times 2.75 \text{ kWh/m}^2/\text{day} \times 0.75 = 41.3 \text{ Wh for winter} \quad (27)$$

Since a radar detector requires around 26.16 W per day, this solar panel is sufficient to supply enough power for the radar detector year round.

Finally, we must select a solar panel for the blinker sign. Since we are using the Tapco battery bank and Day-Viz™ circuitry, which fully supports both the wireless device and the blinking LEDs, the supplied solar panel is used. Its characteristics are summarized in Table 4.

Table 4: Solar Panel Characteristics [12]

Power	Voltage (Voc)	Current Max (Isc)	Current Min (Isc)	Weight	Dimensions
13.5 W	9 V	1500 mA	1400 mA	2.2 lbs	13.7 in x 15.2 in x 0.75 in

Chapter 3: Software Design

3.1 Introduction

Software design is a key part in creating a reliable ALWS. In the ALWS, each component contains a PIC16F690 microcontroller (host) which communicates transparently with an AC4790 wireless transceiver. This chapter describes the programming aspects of the wireless transceiver and the embedded software that controls each component in the ALWS.

3.2 Microcontroller

The microcontroller used in each detector and blinker module is the Microchip PIC16F690, which is a 20-pin, 8-bit CMOS microcontroller with nanoWatt technology. Table 5 summarizes some of the key characteristics of this microcontroller.

Table 5: PIC16F690 Characteristics

Voltage Range	2.0 – 5.0 V
Standby Current @ 2.0V	1.0 nA
Operating Current @ 2.0V	< 1mA
Flash	4096 words
SRAM	256 bytes
EEPROM	256 bytes
I/O	18 pins
10-bit A/D Converter	12 channels
Comparators	2
8-bit Timer	2
16-bit Timer	1

3.2.1 Programming the PIC16F690

In order to program the PIC16F690, the MPLAB Integrated Development Environment (IDE) and Microchip MPLAB In-Circuit Debugger (ICD) 2 are used. The MPLAB ICD 2 creates a connection between the MPLAB IDE and the PIC16F690 through a USB connection. Five pins are needed to program the PIC16F690. They are VDD (pin 1), VSS (pin 20), MCLR (pin 4), ICSPDAT (pin 19), and ICSPCLK (pin 18). Figure 12 shows the pin diagram of the PIC16F690.

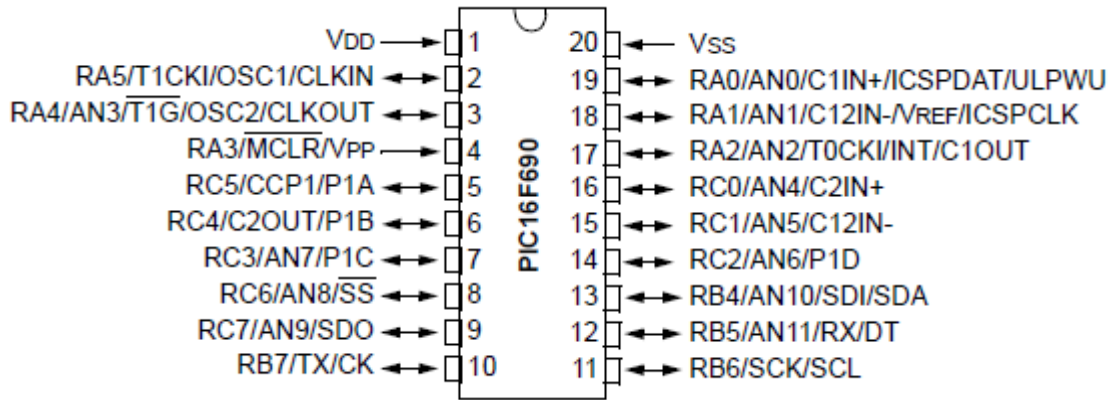

Figure 12: PIC16F690 pin diagram [14].

These 5 pins can be accessed through a supplied RJ-11 (6-pin) cable from the MPLAB ICD 2 debugger. In order to program the custom Printed Circuit Boards (PCBs) developed for the detector and blinker modules, the supplied RJ-11 cable is connected to a custom built RJ-45 (8-pin) socket. The 5 wires from this socket can then be connected to a 5-pin header on each PCB. Figure 13 shows the MPLAB ICD 2 debugger pin diagram from the solder side and the pin diagram of the RJ-45 socket from the top view.

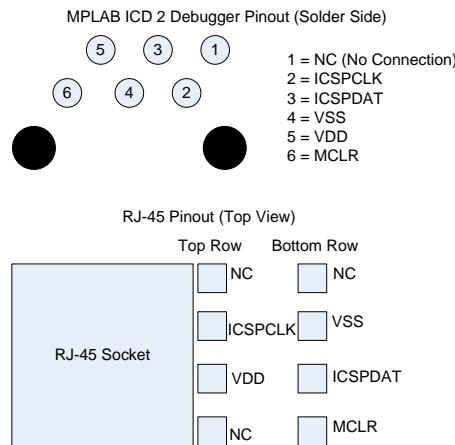

Figure 13: MPLAB ICD 2 debugger and RJ-45 socket pin diagrams.

3.2.2 HyperTerminal Interface

Each detector and blinker PCB has available pins to access the Enhanced Universal Synchronous Asynchronous Receiver Transmitter (EUSART) of the PIC16F690. This allows a HyperTerminal program to monitor the software embedded in each microcontroller. This is useful for debugging the software and adjusting sensor thresholds. The HyperTerminal interface runs on a PC and is connected to a header on each PCB via an RS-232 cable. Three pins are needed to connect a HyperTerminal interface to the PIC16F690. They are RC0 (pin 16) configured as an output pin, RC1 (pin 15) configured as an input pin, and VSS (pin 18). HyperTerminal communication uses a N9600 driven inverted baud rate, no parity, one stop bit,

and no flow control. Figure 14 shows an example of output from a PIR detector displayed on the HyperTerminal interface.

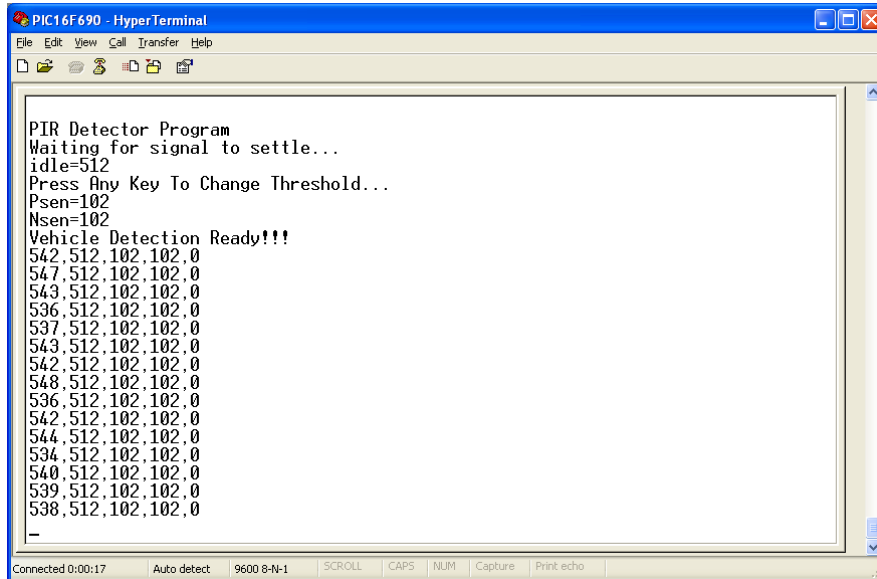

Figure 14: HyperTerminal interface output.

3.3 Wireless Transceivers

The wireless transceivers used for the ALWS are the 900MHz AC4790-200M transceivers manufactured by AeroComm. The AC4790 is a cost-effective, high-performance, transceiver. The line of sight range is estimated at 4 miles (6.4 km). The Masterless architecture is a true peer-to-peer architecture, where any module that has data to transmit will initiate a communication session with a transceiver(s) within its range, transmit data, and exit the session. This architecture eliminates the need for a master which dictates data flow control, hence reducing additional system overhead and greatly improving efficiency.

There are 16 available channels in the 900 MHz band for these transceivers. Since there are two wireless peer-to-peer communications in the ALWS, two different channel numbers must be used. Channel 0 will be used for communication between D1, D4, S2, and S3. Channel 1 will be used for communication between D2, D3, and S1. Table 6 summarizes the components and their Media Access Control (MAC) addresses for each communication channel.

Table 6: Wireless Peer-to-Peer Communications Channels

Channel	detectors	MAC Address	Blinker(s)	MAC Address
0	D1	00 50 67 55 57 95	S2	00 50 67 55 57 87
	D4	00 50 67 55 57 40	S3	00 50 67 55 57 79
1	D2	00 50 67 55 57 85	S1	00 50 67 55 53 14
	D3	00 50 67 55 47 60		

An AeroComm Software Developer Kit (SDK) was purchased. The SDK includes two development boards which contain an AC4790 wireless transceivers, MMCX antenna, power

adapter, RS-232 cable, USB cable, software, and documentation. Each AC4790 transceiver must be configured to be either a detector or a blinker. Using the AC4790 Configuration/Test Utility included with the SDK, each transceiver can be programmed via a USB cable and a Personal Computer (PC).

3.3.1 Detector and Blinker Configuration

The Configure page of the AC4790 Configuration/Test Utility is a Graphical User Interface (GUI) representation of the 256 byte EEPROM contents within the radio. There are five sections on the Configure page; Radio Interface, Radio RF, Radio Features, Radio Other, and Info Center. The Info Center provides a quick description of each setting/mode. For detailed descriptions of the individual settings, please refer to the AC4790 user's manual [13]. The Configure page for both a detector and a blinker can be seen in Figure 15.

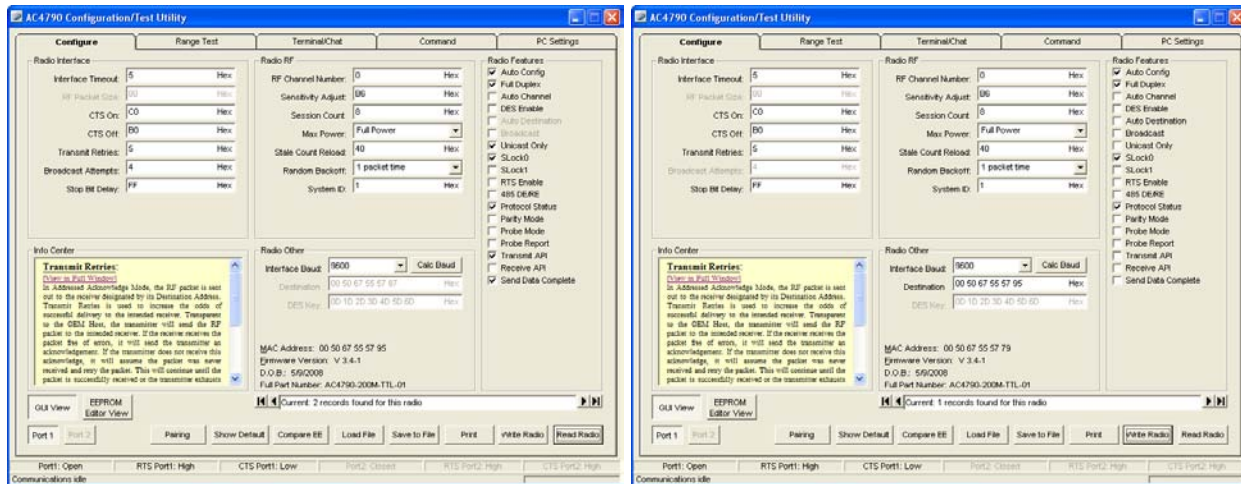

Figure 15: AC4790 detector (left) and blinker (right) transceiver settings.

Once a transceiver is connected to a PC running the AC4790 Configuration/Test Utility via a USB cable, the read button on the Configure page can be used to display the current settings of the AC4790. For a detector, the only changes made to the default settings are the Interface Baud set to 9600, Transmit Retries set to 5, RF Channel Number must be changed to either 0 or 1, and Transmit API, Unicast Only, and Send Data Complete are enabled. Detectors use the Transmit Application Programming Interface (API) to send data packets. Transmit API packet is a powerful command that allows a host to send data to a single or multiple (broadcast) transceivers on a packet-by-packet basis. Figure 16 shows the format of the packet used in API.

0x81	Payload Data Length (0x01 - 0x80)	Session Count Refresh	Transmit Retries/Broadcast Attempts	Destination MAC (2,1,0)	Payload Data
------	--------------------------------------	-----------------------	-------------------------------------	-------------------------	--------------

- 1 If the OEM Host does not encode the header correctly, the transceiver will send the entire string (up to 0x80 bytes) and will look for the header in the next data.
- 2 Although the 7 bytes of overhead are not sent over the RF, they are kept in the buffer until the packet is sent. Keep this in mind so as not to overrun the 256-byte buffer.
- 3 Setting the MAC to 0xFF 0xFF 0xFF will broadcast the packet to all available transceivers.

Figure 16: API transmit packet format [13].

The detectors send data packets to each blinker transceiver using the Unicast Only option. When sending an addressed packet, the packet is sent only to the blinker transceiver specified in the destination address. To increase the odds of successful delivery, Transmit retries are utilized. Transparent to the host, the sending transceiver sends the packet to the intended transceiver. If the transceiver receives the packet free of errors, it will return an acknowledgement within the same 50 millisecond hop. If a receive acknowledgement is not received, the transceiver uses a transmit retry to resend the packet. The transceiver continues to send the packets until either (1) an acknowledgement is received or (2) all transmit retries have been used. The received packet will only be sent to the host if and when it is received free of errors. The API Send Data Complete is used as the software acknowledgement indicator. Figure 17 shows the format of the API Send Data Complete.

0x82	RSSI	RSSI*	0x00: Failure 0x01: Success
------	------	-------	--------------------------------

- 1 The RSSI is how strong the remote transceiver heard the local transceiver; RSSI* is how strong the local transceiver heard the remote transceiver.
- 2 Successful RF Acknowledge updates the Success/Failure bit.
- 3 A success will always be displayed when sending broadcast packets after all broadcast attempts have been exhausted.

Figure 17: API send data complete packet format [13].

For a blinker, the only changes made to the default settings of the Configure page are the Interface Baud set to 9600, Transmit Retries set to 5, and the RF Channel Number must be changed to either 0 or 1. Each detector and blinker is programmed to use full-duplex communication instead of half-duplex. When half-duplex communication is chosen, the AC4790 transceiver sends a packet out over the selected channel whenever it can. This can cause packets sent by multiple transceivers at the same time to collide with each other. To prevent this, full-duplex communication is used. Full-duplex shares the bandwidth intelligently to enable two-way, collision-free communication.

3.4 Embedded Software

All embedded software for this project was coded using PIC BASICPRO (PBP) in the MicroChip Technology MPLAB IDE. The code is downloaded into the PIC16F690

microcontroller using the MPLAB ICD 2 via a USB port. There are four separate software programs created for this project: a program for both PIR detectors, both radar detectors, blinker sign S1, and blinker signs S2 and S3. This section will describe the key software protocols in the four programs.

3.4.1 PIR Detector Protocols

The PIR detector is responsible for processing the output analog signal of the PIR sensor to determine if a vehicle has been detected. Figure 18 illustrates the software flow diagram of the PIR detector.

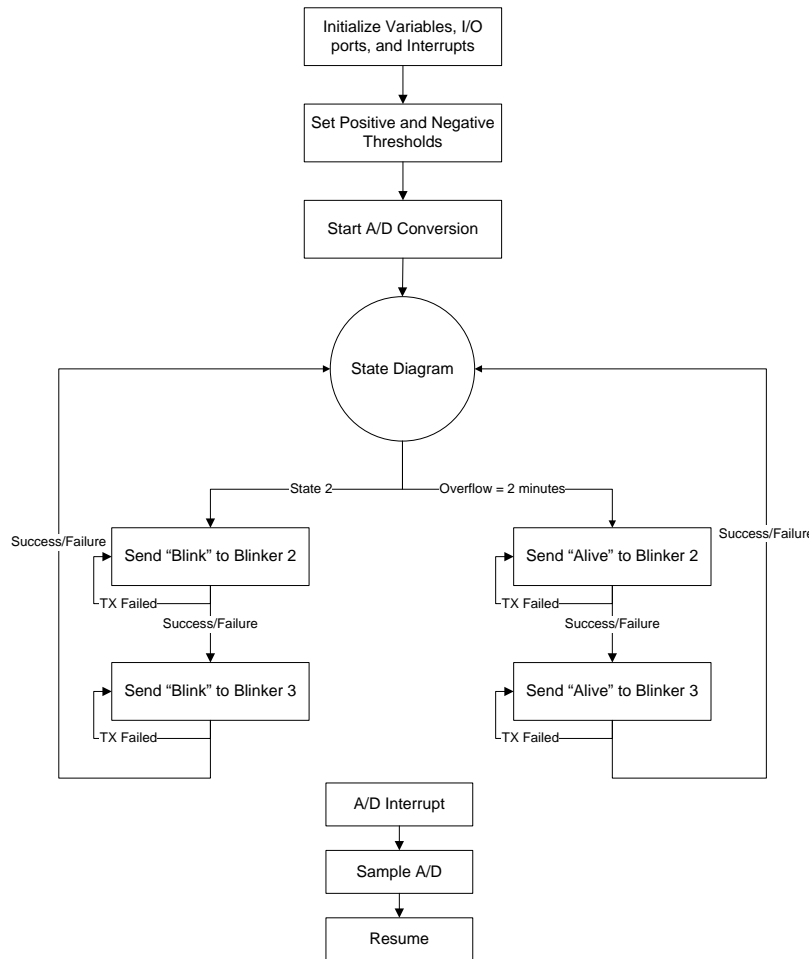

Figure 18: PIR detector software flow diagram.

First, the program starts by defining variables and initializing Ports A, C, and the analog-to-digital converter (ADC) interrupt. Next, positive and negative thresholds can be entered using the HyperTerminal. If a key is not pressed for 2 seconds, the preprogrammed default values are used. These thresholds are used to create a detection range around the idle level of the PIR sensor output signal. Positive and negative thresholds for the PIR sensors are typically set to 20 percent of the idle level. Then the ADC conversion is started. Once the ADC is started, every time a conversion has been completed the ADC interrupt routine is entered. In this routine, if the value

of the ADC sample is outside the detection range an “ON” flag is set. Next, a Finite State Machine (FSM) is entered. If three consecutive samples are inside the detection range, vehicle detection has occurred. A “BLINK” signal is sent to the first sign, S2. If this signal is sent successfully, a “BLINK” signal is sent to S3. If this message is sent successfully, the program returns to the FSM. If a “BLINK” signal fails to send, it will retransmit up to 5 times. If after 5 retransmits the “BLINK” signal did not successfully transmit, an error message will be displayed and the program will move on.

While in the FSM, an overflow counter is used to trigger the sending of an “ALIVE” signal. The “ALIVE” signal is sent every 2 minutes to both S2 and S3. After the “ALIVE” signals are sent, the program returns to the FSM and continues to sample the ADC converter.

3.4.2 Radar Detector Protocols

The radar detector software program starts by defining variables and initializing Ports A, C, and the Timer 1 interrupt. Next, Timer 1 is started and the program enters a FSM where the radar sensor input is polled. The radar sensor outputs a regulated +5 V digital signal which is connected to a digital I/O port on the PIC16F690. The output signal is either high (+5 V) or low (0 V). Since a detection zone needs to be established at each radar detector, the program needs to send two signals: “START” and “END”. Once a vehicle has entered the detection zone, the radar sensor output goes high and a “START” signal is sent to S1. When a vehicle leaves the detection zone, the radar sensor output goes low. In the FSM, the output of the radar sensor needs to be low for 10 consecutive seconds before the “END” signal is sent. This is to ensure that the vehicle has actually left the detection zone. The radar detector software only has to send signals to one blinker sign, S1. If after 5 retransmits either signal did not successfully transmit, an error message will be displayed and the program will move on.

The interrupt routine in the radar detector program is triggered by an overflow of Timer 1. The overflow happens every 2 minutes and triggers the Timer 1 interrupt service routine. In this routine, the “ALIVE” signal is sent to blinker sign S1. Figure 19 illustrates the software flow diagram of the radar detector.

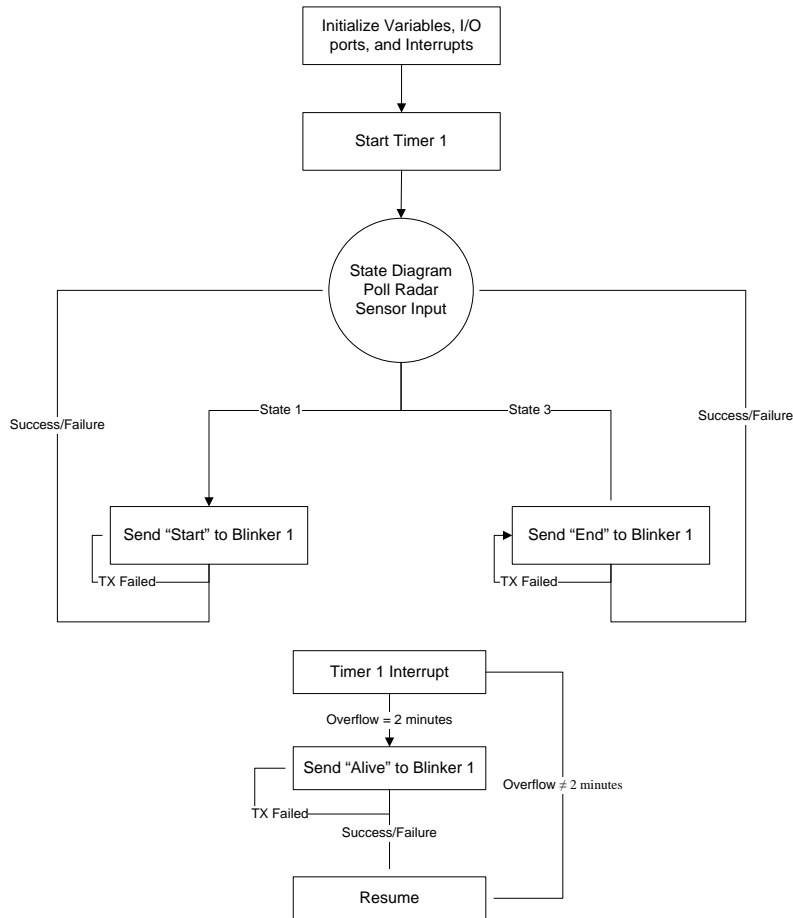

Figure 19: Radar detector software flow diagram.

3.4.3 Blinker Sign S1 Protocols

Blinker sign S1 is responsible for processing the wireless signals received from both of the radar detectors (D2 and D3). A software flow diagram for blinker sign S1 is illustrated in Figure 20. In the main program of blinker 1, variables, Port C, and Timer 1 and its interrupt routine are initialized. Timer 1 is enabled and the program waits for incoming data from either radar detector. Three types of signals can be received from either of the radar detectors. The first signal is a “START” blinking signal. When this signal is received, a vehicle has entered either one of the detection zones at the intersection. Here, the overflow counter is reset, the “BLINK” variable is incremented, and the blinking LEDs are turned on. The second signal is an “END” blinking signal. When this signal is received, a vehicle has exited either one of the detection zones at the intersection. Here, the overflow counter is reset, the “BLINK” variable is decremented, and the LEDs are turned off. The third signal is an “ALIVE” signal. When this signal is received, the overflow counter is reset. If a “START”, “END”, or “ALIVE” signal is not received from a radar detector for more than ten minutes, the blinker sign will enter default mode and the LEDs will blink continuously.

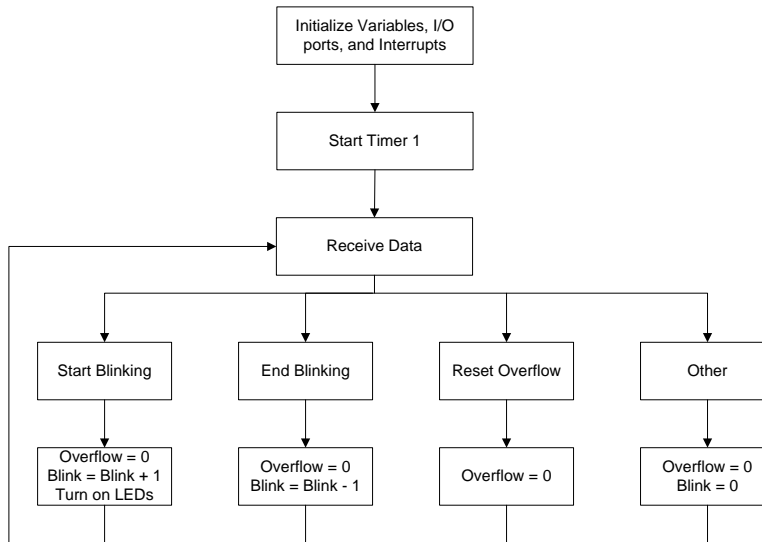

Figure 20: Blinker 1 software flow diagram.

3.4.4 Blinker Sign S2 and S3 Protocols

Blinker signs S2 and S3 are responsible for processing the wireless signals received from both PIR detectors (D1 and D4). A software flow diagram for blinker signs S2 and S3 is illustrated in Figure 21. In the main program of blinker’s 2 and 3, variables, Port C, and Timer 1 and its interrupt routine are initialized. Timer 1 is enabled and the program waits for incoming data from either PIR detector. Two types of signals can be received from a PIR detector. The first signal is a “START” blinking signal. When this signal is received, a vehicle has been detected. Here, the overflow counter is reset, the “BLINKTIME” variable is set to 10 seconds, and the blinking LEDs are turned on. The flashing LEDs will turn off after 10 seconds unless another “START” signal has been received before the “BLINKTIME” variable reaches zero. If this happens the “BLINKTIME” variable will be reset to 10 seconds. The second signal is an “ALIVE” signal. When this signal is received, the overflow counter is reset. If either a “START” or “ALIVE” signal is not received from a PIR detector for more than ten minutes, the blinker sign will enter default mode and the LEDs will blink continuously.

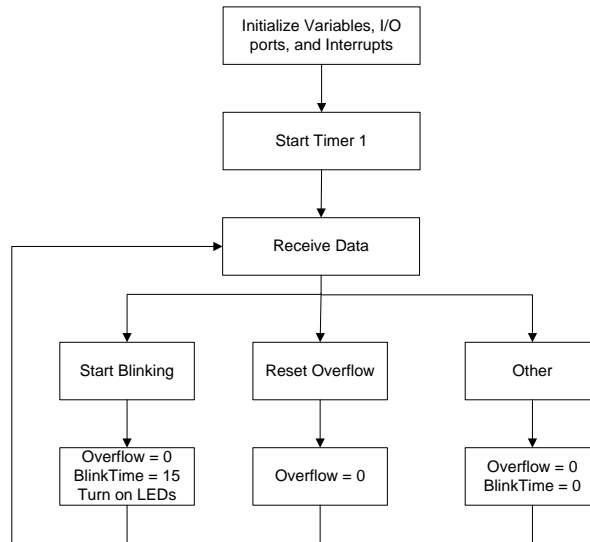

Figure 21: Blinker's 2 and 3 software flow diagram.

3.4.5 Alive Signals

All three blinker signs contain the phrase “WHEN FLASHING” in their respective warning messages. If any of the four vehicle detectors fail, vehicles are not being detected and therefore warning signs are not activated as desired. Not having a blinker sign activate when a vehicle is detected is an undesired effect and must be avoided.

A PIR and radar detector will fail when its power supply falls below the low voltage disconnect (LVD) value specified by battery type and charge controller (Section 2.2.4). When a detector fails, it is unable to send an “ALIVE” signal to its respective blinker sign. Therefore, a fail-safe mode has been implemented into each blinker sign. If a blinker sign has not received any type of wireless signal for more than ten minutes, it will enter into the default mode and the LEDs will continuously blink. This assures that if a vehicle detector is not working, the blinker signs will be automatically switched to a preset default mode.

Chapter 4: Testing

4.1 Introduction

Lab and on-site testing had three main goals: selecting a wireless module, sensors, and testing PCB prototypes. Testing of wireless modules included selecting a low-cost, low-power module that had the capability of transmitting the sufficiently long distance (longer than required) between a detector and a blinker sign. Since vehicle sensors are the largest consumers of electrical energy in each vehicle detector module, it is crucial to select low-power sensors to maintain a self-sufficient renewable energy system and that meet the detection requirements for both major and minor approach traffic. And finally, several versions of the PCBs that control each vehicle detector and blinker sign were designed and tested in lab before installation.

4.2 Wireless Module Testing

Wireless module testing began by researching several different possible solutions. After extensive research, the 900MHz AC4790-200M transceivers manufactured by AeroComm were selected. The AC4790 is a cost effective, high performance, Masterless architecture transceiver; The line of sight range is estimated at 4 miles (6.4 km). The Masterless architecture is a true peer-to-peer architecture, where any module that has data to transmit will initiate a communication session with a transceiver(s) within its range, transmit data, and exit the session. Communication is initiated by a PIC16F690 microcontroller. The PIC16F690 chooses the destination address and the type of message being sent. A packet is sent to the AC4790 module and transmitted. When a packet is received, it is immediately passed to the PIC16F690 and the proper action is taken depending what type of message was received.

In order to test the AC4790 wireless module, an AeroComm Software Developer Kit (SDK) was purchased. The SDK includes two development boards which contain AC4790 wireless transceivers, MMCX antenna, power adapter, RS-232 cable, USB cable, software, and documentation. Using a development board, the AC4790 was interfaced with the PIC16F690 microcontroller, a 5 V regulator, LEDs, and a pushbutton. The whole system was powered by a 12 V battery. This initial configuration is shown in Figure 22.

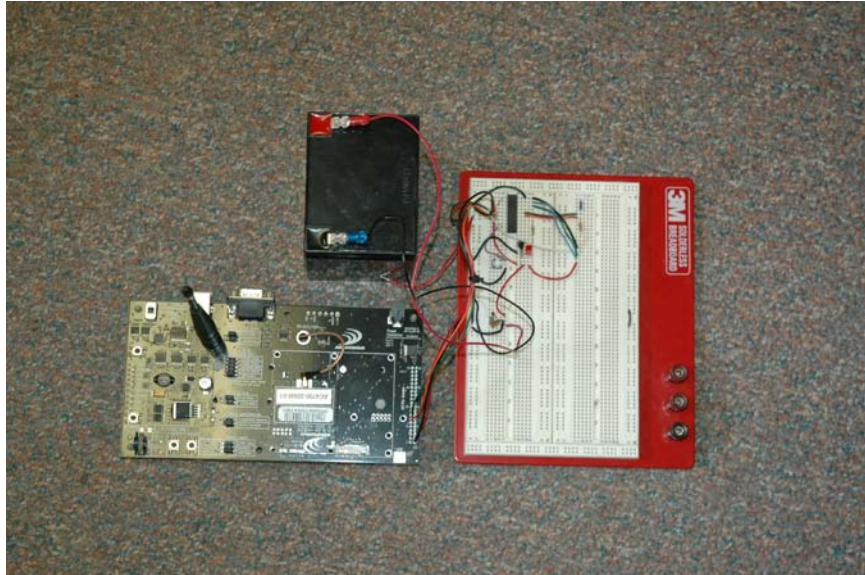

Figure 22: Testing of the AeroComm AC4790 SDK.

Once the AC4790 module was successfully integrated with the PIC16F690, two wireless modules were created: a detector and a blinker (Figure 23). PCBs for these modules were created and housed in an enclosure.

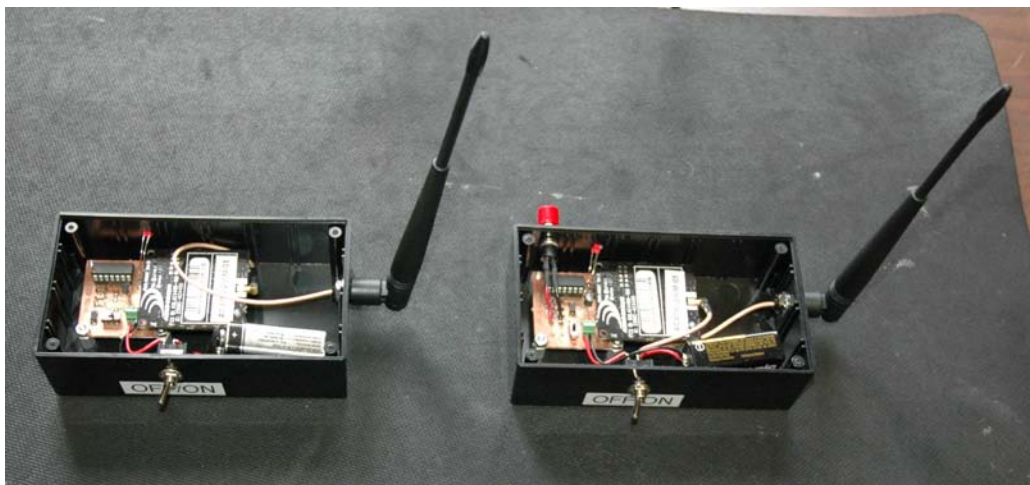

Figure 23: Detector (left) and blinker (right) wireless test modules.

The module on the left is the wireless blinker. The module on the right is the wireless detector. When the button on the detector is pushed, signifying vehicle detection, a wireless signal is sent to the Blinker. When the blinker receives the wireless signal from the detector, the LED will flash three times. These two modules were taken to the actual intersection and tested. The purpose of this test was to ensure that the wireless signal could travel from the bottom of the vertical curve to the intersection where each blinker sign is located. Also, wireless transmission was tested from each stop sign to the location of the blinker sign on West Tischer Road. In addition, several orientations of each module's antenna were tested. There was not a single case

where the wireless signal was not received. Since communication was successful in every test, the need for repeaters in this system was eliminated.

4.3 Sensor Testing

Vehicle detection in this system occurs in two positions. The first position is at each stop sign on Eagle Lake Road. These sensors need to be able to detect vehicles in a detection zone. A detection zone is necessary to detect vehicles as they approach the intersection and as they are waiting at the intersection. The second position is detecting vehicles traveling west bound on West Tischer Road. This sensor needs to detect a vehicle traveling at high speeds and only in a single lane. There are several options for the type of sensor that could be used for detecting vehicles. This includes Anisotropic Magnetoresistive (AMR), radar, ultrasonic, and infrared sensors.

4.3.1 PIR Sensor Testing

A Passive Infrared sensor (PIR) is an electronic device that measures infrared (IR) light radiating from objects in its field of view. Motion is detected when an IR source with one temperature, such as a vehicle, passes in front of an IR source with another temperature, such as a roadway. The term passive in this instance means that the PIR device does not emit an infrared beam but merely passively accepts incoming infrared radiation. The key advantages of a PIR sensor are fast detection, adjustable sensing fields, and no false detection from inanimate objects. This sensor uses spot detection with a maximum range of 16.4 ft (5.0 m).

The PIR sensor itself was housed in a hard plastic enclosure and sealed with weatherproof potting compound. The sensor points out through a plastic lens. The purpose of this lens is to focus the sensor's direction to a specific point instead of a large area. Three wires: power, ground, and the analog output signal are connected through a conduit to the sensor circuit. The PIR test circuit consists of an AC4790 wireless module, a wireless antenna, a PIC16F690 microcontroller, and a 9 V battery. A LED signifies vehicle detection. The PIR sensor and circuitry was mounted on a free-standing square channel pole shown in Figure 24.

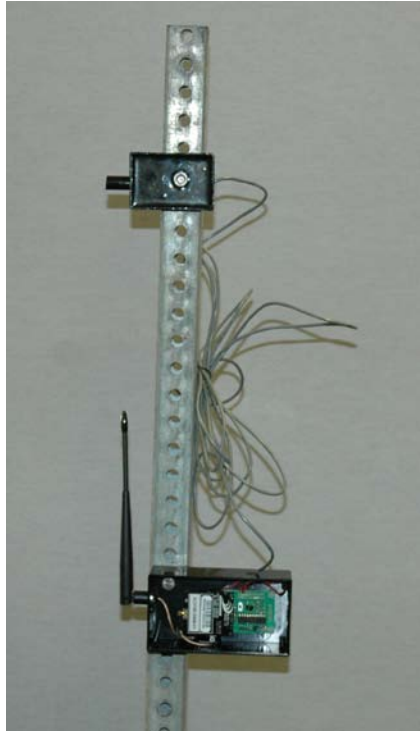

Figure 24: PIR sensor test circuit.

First, the PIR sensor test circuit was tested in a parking lot at the University of Minnesota Duluth (UMD). This test simply involved driving two types of vehicles past the sensor at low speeds. After successful testing, the test circuit was taken to the actual test site and mounted on a u-channel sign post positioned 15 ft (4.6 m) from the westbound lane of West Tischer Road. Here the sensor was tested on a variety of vehicles traveling at high speeds. Detection occurred 100 percent of the time and it was determined that this sensor would be used for the two detectors (D1 and D4) on West Tischer Road.

4.3.2 Ultrasonic Sensor Testing

An ultrasonic sensor measures distance by transmitted an ultrasonic pulse from the unit and distance-to-target is determined by measuring the time required for the echo to return. Advantages of an ultrasonic include directional sensitivity, sensitive to virtually all objects, and are not affected by vibration, infrared radiation, or ambient noise.

The first ultrasonic sensor tested was the PING Ultrasonic Distance Sensor. This sensor provides non-contact distance measurements from about 0.8 in (2 cm) to 9.84 ft (3 m). Three wires: power, ground, and the variable-width output pulse signal are connected through a conduit to the sensor circuit. The PING sensor is powered by a 5 V supply and consumes about 30 mA. This sensor was originally planned to work along with a PIR sensor to create the detection zone needed at each stop sign on Eagle Lake Road. When a vehicle approaches the intersection, a PIR sensor can easily detect it. But if the vehicle must wait at the stop signs for the intersection to clear, a problem occurs. The problem is that when a vehicle is waiting at a stop sign it usually pulls up much closer to West Tischer Road leaving the detection range of the PIR sensor. During

this case, the warning sign (S1) on West Tischer Road must continue to blink because there still is a vehicle at the intersection. Another sensor is then needed to sense this waiting condition. It was determined that this sensor must be able to detect vehicles 24 feet in front of each stop sign at an angle of 45°.

A simple circuit was built and the PING sensor was tested in a parking lot at UMD. It was determined that the maximum distance was not sufficient to detect vehicles at the required distance of 24 ft (7.3 m). Also, the PING sensor performs well when facing the side of a vehicle head on. But when angled at a vehicle, the ultrasonic waves did not reliably reflect back to the sensor and thus failing vehicle presence detection.

A more powerful ultrasonic sensor was purchased, the SonaSwitch 1400 ultrasonic sensor. This sensor was designed for industrial applications such as proximity detection and vehicle detection at drive-ups. The SonaSwitch 1400 ultrasonic sensor has a range of 1.5 ft (0.46 m) to 35 ft (10.7 m) and provides one Normally Open (NO) relay contact output along with power and ground connections. This NO contact was connected to a buzzer tied to a 3.7V battery. The sensor was powered by a 12 V battery and draws about 50 mA. When detection occurs, the relay will close causing the buzzer to sound. The maximum detection distance is adjusted by a “Range Control” potentiometer. This sensor was housed in a single gang electrical box. The SonaSwitch sensor was mounted on a free-standing square channel pole shown in Figure 25.



Figure 25: SonaSwitch ultrasonic test circuit.

Although the maximum distance of this sensor was listed at 35 ft (10.7 m), the actual maximum distance achievable was only 22 ft (6.7 m) when tested outside against a brick wall. The sensor was then tested at the actual intersection by mounting it on one of the present stop signs on Eagle Lake Road. Although it performed better than the PING ultrasonic sensor, it still encountered similar problems. First, the distance of vehicle detection was not quite enough to

detect vehicles waiting at the intersection and the angle in which cars needed to be detected also affected detection.

4.3.3 Radar Sensor Testing

The radar sensor tested is the Banner R-Gage QT50RAF Sensor. This radar sensor uses Frequency Modulated Continuous-wave (FMCW) radar. FMCW radar transmits a frequency sweep, often called a chirp. The signal is reflected from distant targets and detected by the receiver. By measuring the frequency of the return signal, the time delay between transmission and reception can be measured and therefore the range is determined. Advantages of this sensor are that it can detect both moving and stationary objects. Also, using the R-Gage radar sensor allows a detection zone to be present at each stop sign. Vehicles are detected as they enter the detection zone and remain detected until they leave the detection zone. This allows for only one sensor to be used at each stop sign instead of the previously mentioned sensor configuration of one PIR sensor and one ultrasonic sensor per stop sign. Figure 26 shows the Banner R-Gage Radar sensor.



Figure 26: Banner R-Gage QT50RAF sensor.

The sensor can be configured (via DIP switch) to sense objects up to a specific distance, ignoring objects beyond this distance. Also, the sensitivity, output configuration, and response speed can be adjusted. Figure 27 summarizes the radar sensor configurations.

DIP Switch Functions

Switch	Function
1, 2, 3	Sensing distance (detects objects from sensor face to this point)
4, 5, 6	Sensitivity (higher sensitivity sees weaker objects and has a wider beam pattern)
7	Normally open/normally closed output functionality
8	Response speed

Sensing Distance Settings

Switch 1	Switch 2	Switch 3	Distance	
			EU Model	All Other Models
0	0	0	2 m	3 m
0	0	1	3 m	4 m
0	1	0	4 m	5 m
0	1	1	6 m	6 m
1	0	0	8 m	8 m
1	0	1	10 m	10 m
1	1	0	12 m	12 m
1	1	1	15 m	15 m

Sensitivity Selection

Switch 4	Switch 5	Switch 6	Sensitivity	Beam Width
0	0	0	8	Wide ↓ Narrow
0	0	1	7	
0	1	0	6	
0	1	1	5	
1	0	0	4	
1	0	1	3	
1	1	0	2	
1	1	1	1	

Output Configuration

Switch 7	Normally Open/Normally Closed
0	N.O.
1	N.C.

Response Speed

Switch 8	ON	OFF	ON/OFF
0	32 ms	68 ms	100 ms
1	258 ms	998 ms	1256 ms

Figure 27: Radar sensor DIP switch configurations [15].

The sensor was then tested at the actual intersection by mounting it on one of the present stop signs on Eagle Lake Road. For the testing, the following configuration was used:

Distance = 8 m

Sensitivity = 6

Output = Normally Open

Response Speed: On = 32 ms, Off = 68 ms, On/Off = 100 ms

The distance from the stop sign where each radar sensor would be mounted to where a vehicle would typically come to a stop at the intersection is 24 ft (7.3 m). Naturally, the sensing distance was then set to 26.3 ft (8 m) in order to include the measured distance. The sensing distance determines the length of the detection zone. The sensitivity of the sensor determines the width of the detection zone. The sensitivity was determined by actual testing at each stop sign. After obtaining very good results from on-site testing, it was determined that this sensor would be used for the two detectors (D2 and D3) on Eagle Lake Road.

Figure 28 shows an example of a typical beam pattern for the R-Gage radar sensor. As the sensitivity increases, the diameter of the detection zone increases.

Typical Beam Pattern 200 mm Metal Corner Cube (Similar to a Large Vehicle)

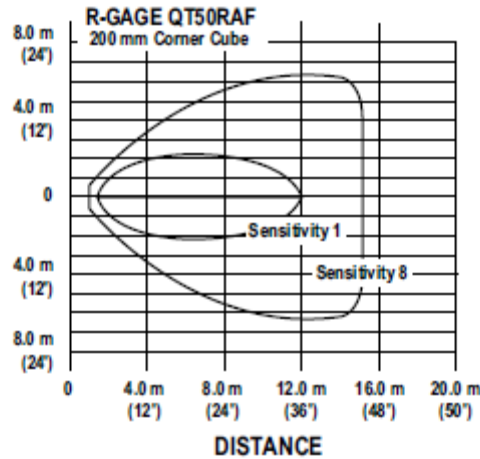

Figure 28: Typical beam pattern of the R-Gage radar sensor [15].

The radar sensor has three connections: 12 V, GND and 12 V digital output signal. This 12 V digital output signal is regulated down to 5 V in order to meet the input voltage specifications of an input/output (I/O) port on the PIC16F690.

4.4 PCB Design and Testing

The ALWS consists of 7 components: three blinker signs, two PIR detectors, and two radar detectors. Each component contains electronic circuitry which controls vehicle detection, blinking LEDs, and wireless communication. PCBs that contain the electronics were designed and built using Mentor Graphics PADS software and a ProtoMat S62 Prototyping machine. Several versions of each PCB were built. The following sections describe the final versions of each PCB.

4.4.1 Blinker Sign PCB

The three LED blinker signs used in the ALWS were purchased from Tapco. These signs consist of eight LEDs on the perimeter of a yellow warning sign, a solar panel, a battery bank, and circuitry. Once powered, the Tapco BlinkerSigns® continuously blink. In order to convert the original Tapco BlinkerSigns® into ALWS blinker signs, the PCB added to each blinker sign needs to be powered by the Tapco battery bank and provide a way to control the blinking duration.

The PCB design for the blinker signs is shown in Figure 29. The voltage supplied by the Tapco batteries is 4.8 V. This is regulated (U2) down to 3.3 V in order to power both the PIC16F690 microcontroller (U1) and the AC4790 wireless module which is attached using a 20-pin header (J1). J2 is a 5-pin header used to program the PIC16F690 using a laptop running MPLAB IDE and a Microchip MPLAB ICD 2 programmer. D3 is an indicator LED used to

signal power-up and if a wireless signal has been received from a detector. This LED can be turned on or off using the jumper (J4). During a normal operation at the site, the jumper should be set to off to save on battery power. U3 is an on/off switch which controls power to the PCB.

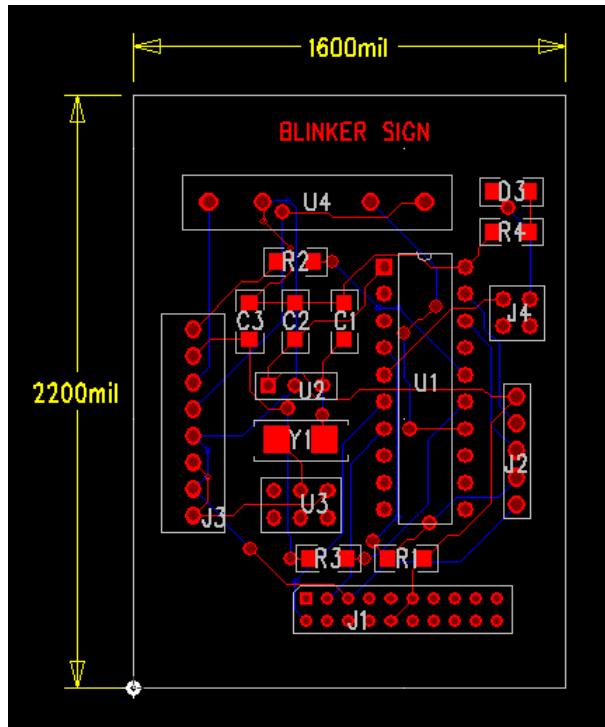

Figure 29: Blinker sign PCB layout.

Originally, the power line connected the Tapco battery directly to the original electronics. This power line was cut and fed into pins 1 and 2 of the 8-pin header (Figure 30) supply power to the PCB. Pins 3 and 4 are used to supply power back to the Tapco electronics. Pins 5 and 6 are connected to a relay to control the blinking of the LEDs. Pins 7 and 8 are used to connect the HyperTerminal serially to the PIC16F690.

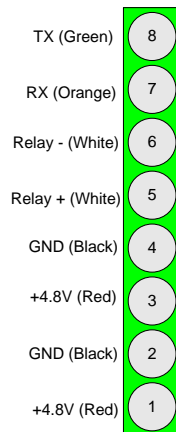

Figure 30: Blinker sign 8-pin header.

The Tapco BlinkerSigns® were originally designed to blink continuously. Since the warning signs in ALWS only blink for a fixed period of time when a vehicle has been detected, modifications to the blinking wiring also had to be made. The positive side of the original wire that controlled the blinking was cut. Both ends were fed into pins 5 and 6 of the 8-pin header. Connections from the header were made to a relay which was controlled by a signal sent for an I/O port of the PIC16F690 to control the blinking.

Originally, a Hamlin HE3300 relay was used to control the blinking. During testing it was found that this relay was not operating correctly. This was because this relay is designed for a minimum control voltage of 5 V. The PIC16F690 is powered by 3.3 V so the I/O ports can only supply 3.3 V. Since this is under the specification of 5 V, the relay would sometimes not return to its normally open state and the LEDs on the warning sign would not stop blinking. The LCA710 OptMOS relay manufactured by Clare solved this problem.

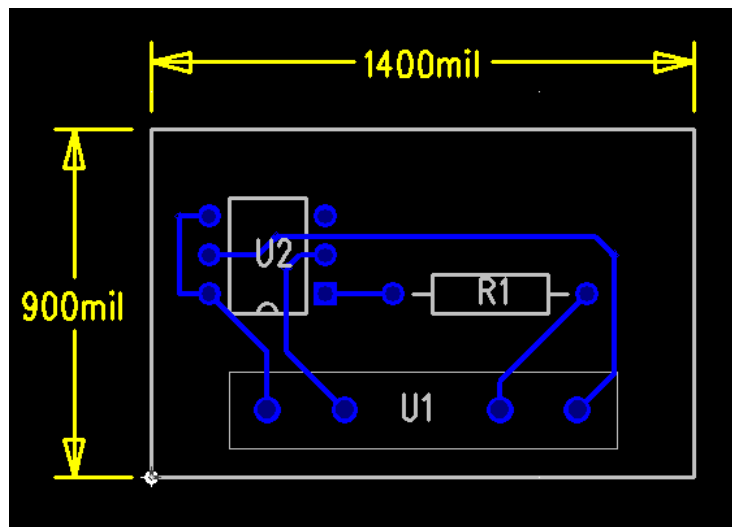

Figure 31: Blinker sign relay PCB layout.

A new PCB board was created (Figure 31) using a LCA710 Single Pole OptMOS relay. It uses optically coupled MOSFET technology with a load current rated at 1 A. The minimum control voltage for this chip is 1.2 V and the recommended control current is 10 mA. Using this control current and the 3.3 V supplied by an I/O pin the following equation yields the resistor value (R1) to produce this current:

$$V = IR \rightarrow R = \frac{V}{I} = \frac{3.3V}{10mA} = 330\Omega \quad (28)$$

The new relay PCB is connected to the main blinker sign PCB by soldering four wires between U1 (Figure 31) and U4 (Figure 30).

4.4.2 PIR Detector PCB

The PCB layout for the PIR detectors is shown in Figure 32. The PIR detector voltage is supplied by a 12 V lead-acid battery. This is regulated (U2) down to 5 V in order to power the

PIC16F690 microcontroller (U1), the MAX233 RS-232 Driver, and the AC4790 wireless module which is attached using a 20-pin header (J1). J2 is a 5-pin header used to program the PIC16F690. D3 is an indicator LED used to signal power-up and vehicle detection. There is also an external LED designed for the same purpose. The jumper (J4) is used to switch between these two LEDs. During actual implementation, the jumper is set so the external LED is used. U3 is an on/off switch which controls power to the PCB.

During testing it was noticed that communication between the PIC16F690 and the HyperTerminal was causing the PIC16F690 to behave unexpectedly. This did not happen in the lab with a short cable but happened when a long serial cable was connected at the site. Commonly, the serial signals of the PIC16F690 chip are driven through resistor loads that convert signals from 0 - 5 V to -15 - +15 V RS-232 signals utilizing the serial port signal strength (-15 - +15 V) of a PC. This approach worked for short distances (less than few feet), but it was problematic for longer distances. To correct this problem, a MAX 233 RS-232 Driver (U4) was used with a few external capacitors to reliably communicate with the PIC16F690. The addition of a RS-232 driver completely resolved the serial communication issue.

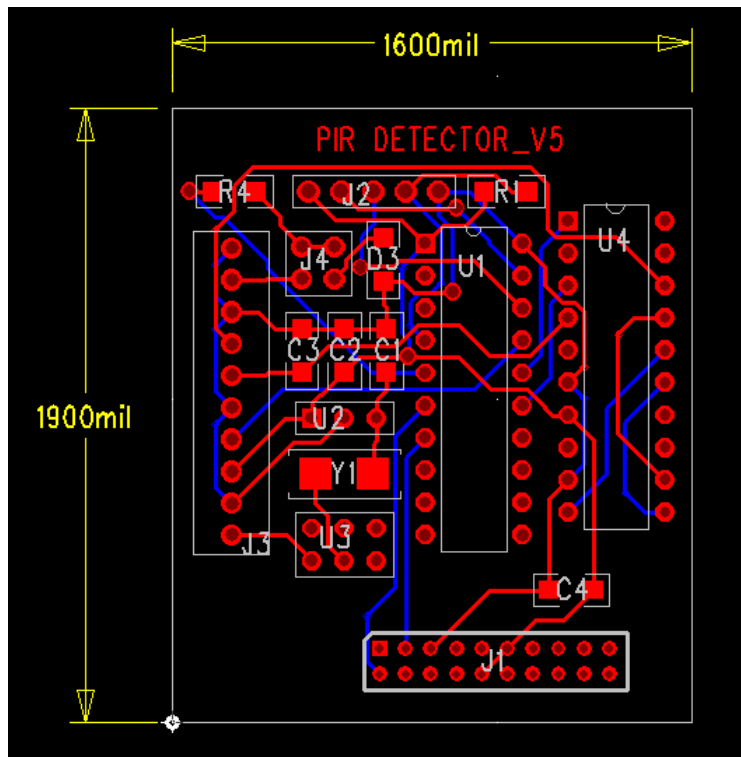

Figure 32: PIR detector PCB layout.

On the 10-pin header (J3) shown in Figure 33, pins 1 and 2 are used supply power to the PIR detector PCB. The PIR sensor is connected to the PCB via three wires: +5 V, GND, and signal. These wires are connected to pins 3, 4, and 5 on the 10-pin header. Pins 6, 7, and 8 are used to connect a PC running a HyperTerminal program to the PCB. Pins 9 and 10 are used to connect the external indicator LED.



Figure 33: PIR detector 10-pin header.

4.4.3 Radar Detector PCB

The radar detector voltage is supplied by an 11.1 V Li-ion battery. This is regulated (U2) down to 5 V in order to power the PIC16F690 microcontroller (U1), and the AC4790 wireless module which is attached using a 20-pin header (J1). J2 is a 5-pin header used to program the PIC16F690. D3 is an indicator LED used to signal power-up and vehicle detection. This LED can be turned on or off using the jumper (J4). During actual implementation, the jumper should be set to off to save on battery power. U3 is an on/off switch which controls power to the whole radar detector system.

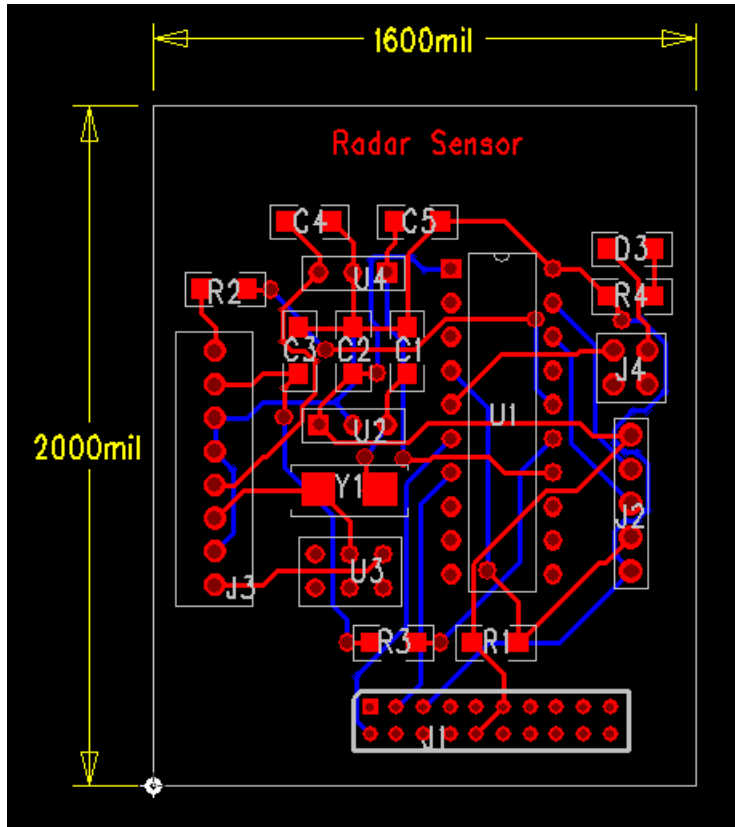

Figure 34: Radar detector PCB layout.

The radar detector PCB is powered by 11.1 V from the Li-ion batteries. This connection is made on pins 1 and 2 of the 8-pin header. The radar sensor is connected to the PCB via three wires: +12 V, GND, and signal. These wires are connected to pins 3, 4, and 5. Pins 6, 7, and 8 are used to connect the PIC to a PC running a HyperTerminal program.



Figure 35: Radar detector 8-pin header.

Chapter 5: Installation

On September 23, 2009, the actual installation of the ALWS took place. The on-site installation of the seven components took a full day with help from the St. Louis County Sign Shop. Before installation could take place, all components were pre-built in lab.

5.1 Detector Assembly

The PIR detector contains of two rechargeable AGM lead-acid batteries, the SunSaver-20L Solar Charge Controller, and wireless circuitry including the AC4790 module. The charge controller has inputs for solar panel, battery, and load. The two batteries are wrapped in insulation to protect them from extreme cold conditions. These components are mounted on the solar panel housing and shown in Figure 36.

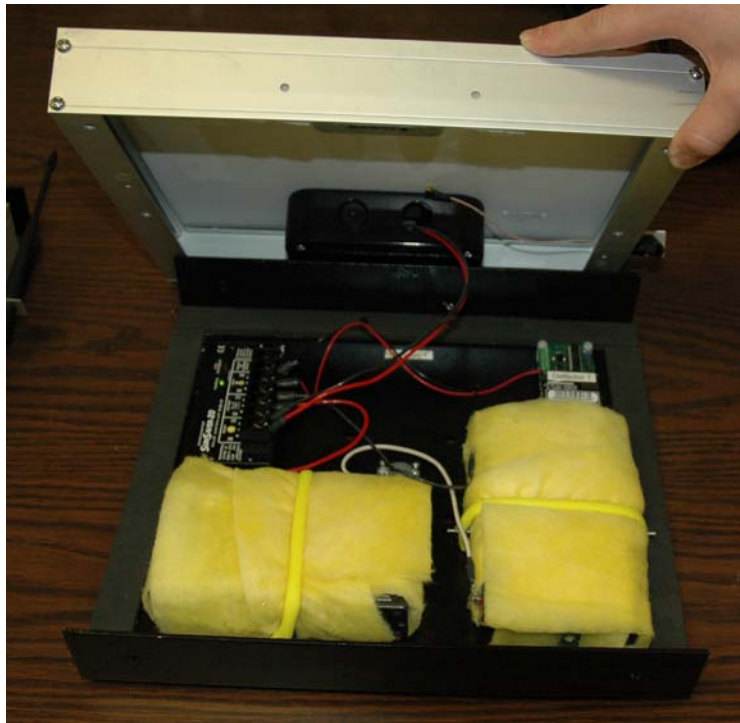

Figure 36: PIR detector assembled solar panel housing.

The PIR detector uses an 11 W solar panel to charge its batteries. This solar panel was ordered with the optional J-box configuration. The J-box extends the frame of the solar panel to a depth of 2 in (5.1 cm). This configuration along with the 10 W solar panel housing built by Povolny Specialties allows components to be mounted inside the solar panel. The solar panel is attached to the solar panel housing via four self-tapping screws. Rubber weather stripping along the edges of the solar panel housing creates a seal when the two units are screwed together. This protects the components inside from rain and snow. There are two holes at the bottom of the solar panel and housing that allow air to circulate. These holes are covered by a filter that traps dust and prevents insects from entering the solar panel. A wireless antenna (not shown) is

connected to the AC4790 module. The antenna is mounted on the outside of the solar panel in the upper right corner. All screw holes are sealed with black Hi-Temp RTV Silicone.

The radar detector contains two rechargeable Li-ion batteries, the Genasun GV-4 Solar Charge Controller, and wireless circuitry including the AC4790 module. Since the Genasun GV-4 Solar Charge Controller only has inputs for the solar panel and the battery, a separate electrical terminal block is used to connect the battery to the load. The two batteries are wrapped in insulation to protect them from extreme cold conditions. These components are mounted on the solar panel housing and shown in Figure 37.

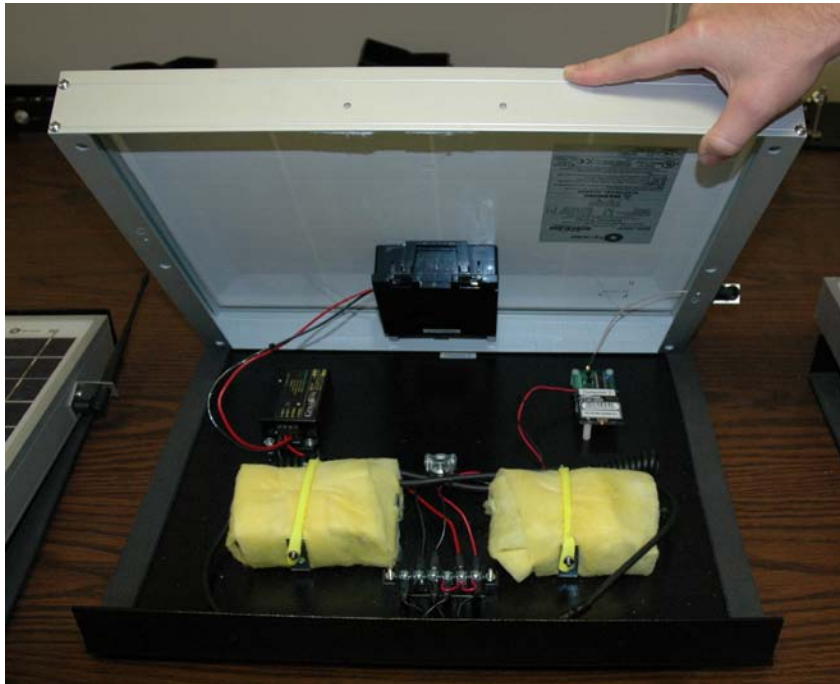

Figure 37: Radar detector assembled solar panel housing.

The radar detector uses a 20 W solar panel to charge its batteries. This solar panel was also ordered with the optional J-box configuration. Rubber weather stripping along the edges of the solar panel housing creates a seal when the two units are screwed together. A wireless antenna (not shown) is connected to the AC4790 module. The antenna is mounted on the outside of the solar panel in the upper right corner. All screw holes are sealed with black Hi-Temp RTV Silicone.

Each assembled solar panel and housing is attached to a solar panel mounting bracket. This bracket, also built by Povolny Specialties, is designed to mount to a u-channel sign post. Figure 38 shows an image of the solar panel mounting bracket (left) and the mounted solar panel housing (right). Also shown in the figure is the mounting bracket for the radar sensor. This mounting bracket, built by Povolny Specialties, allows the radar sensor to be adjusted both vertically and horizontally.



Figure 38: Solar panel mounting bracket (left) and attached solar panel housing (right).

The design of the solar panel mounting bracket also allows the position of the solar panel to be adjusted both horizontally and vertically. After the solar panels are installed on the u-channel sign post, the solar panels need to be adjusted in order to produce the most power for the available solar energy. Solar panels produce the most power when they are pointed directly at the sun. Since the solar panels are attached to a permanent structure, the solar panels should be pointed in a south direction and be tilted at an angle dependent on the location's latitude in order to achieve the highest energy output. Table 7 lists the recommended tilt angles for a fixed system.

Table 7: Recommended Solar Panel Tilt Angles for Fixed Systems [16]

Site Latitude	Fixed Tilt Angle
0° - 15°	15°
15° - 25°	Same as Latitude
25° - 30°	Latitude + 5°
30° - 35°	Latitude + 10°
35° - 40°	Latitude + 15°
40°+	Latitude + 20°

According to Google Maps [7], the Latitude and Longitude of the intersection site are 46.8 ° N and 92.1 ° W. Referring to Table 7, the fixed tilt angle would then be:

$$\text{Latitude} + 20^\circ = 46.8^\circ + 20^\circ = 66.8^\circ \quad (29)$$

The solar panel tilt angle is the measure between the solar panel and the ground. Figure 39 shows a diagram of the tilt angle.

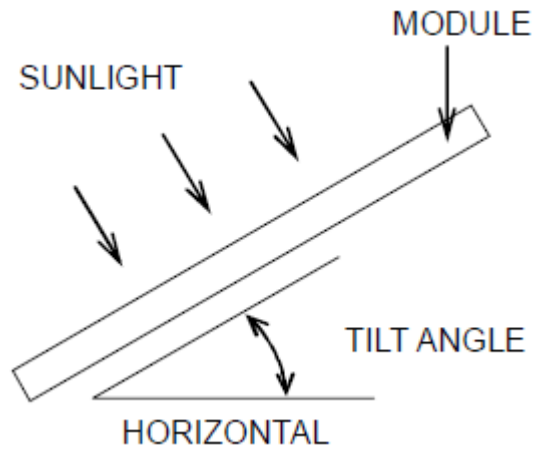

Figure 39: Solar panel tilt angle [16].

5.2 Blinker Assembly

The wireless circuitry for the blinker signs is mounted in a small plastic enclosure screwed to the back of the supplied Tapco solar panel. The wireless antenna is mounted on the outside of this enclosure. The Tapco battery must be charged for 24 hours prior to installation. The battery bank slides into a metal tube mounted on the back of the warning sign. Connections are made to for the LEDs and solar panel. The solar panel then mounts on top of the metal tube and is locked in place with three hex nuts. Complete Tapco installation instructions can be found in Appendix B. Figure 40 shows the back of the Tapco solar panel with the additional wireless and relay circuitry (left) and a complete blinker sign without any lettering (right).



Figure 40: Modified Tapco circuitry (left) and complete blinker sign.

5.3 On-Site Installation

On September 23, 2009, the actual installation of the ALWS took place. The installation started at 8:00 AM and was completed by 3:30 PM. Four St. Louis County Sign Shop workers: Kent Lunda, Mike Turnbull, Steve Anderson, and Dan Feiro helped with the installation.

5.3.1 Radar Detector Installation

The first component that was installed was the radar detector (D3) located in the southeast quadrant of the intersection. Originally, the stop signs at Eagle Lake Road were mounted between two 8 ft (2.4 m) u-channel sign posts. These two posts are bolted to two 8 ft (2.4 m) u-channel sign posts buried 6 ft (1.8 m) in the ground. In order to compensate for the extra weight being added to the stop sign by the radar detector, another u-channel sign post was needed. This sign post acted as a brace and was attached at a 45° on the back of the stop sign and to another post buried in the ground. A utility truck was used to hold the stop sign while the radar detector components were being installed on the sign. Figure 41 shows an image of the utility truck holding the stop sign.



Figure 41: Utility truck holding the first radar detector stop sign.

The first step in installing the radar detector components on the stop sign was to mount the solar panel bracket. The initial design of this bracket was to mount on square sign posts with widths ranging from 2 ¼ – 3 in (5.7 – 7.6 cm). A u-channel sign post has a width of 2 in (5.1 cm). A piece of 1 in (2.5 cm) square sign post placed inside the u-channel sign post in order increase the width and allow the solar panel bracket to be mounted securely. Future solar panel brackets have been modified to fit u-channel sign posts with widths ranging from 1.5 in – 2.5 in (3.8 cm – 6.4 cm). Next, the radar sensor bracket was bolted to the u-channel sign post just

below the solar panel bracket. Figure 42 shows an image of the solar panel and radar sensor brackets.



Figure 42: Mounted solar panel and radar sensor brackets.

The solar panel housing was then attached to the solar panel bracket. The sign was lifted into place and bolted to the three u-channel posts buried in the ground. Once the sign is in position, the solar panel needed to be adjusted to face south and tilt vertically at an angle of 66.8° . A compass was used to face the solar panels south and a cardboard cut-out was used to adjust the tilt angle. Figure 43 shows the adjusting of the solar panel tilt angle using the cardboard cut-out.



Figure 43: Adjusting the solar panel tilt angle.

Finally, the position of the radar sensor was adjusted and the installation of the first radar detector was complete. Figure 44 shows an image of the installed radar detector (D3). The second radar detector (D2) was installed in the same fashion.



Figure 44: Installed radar detector.

5.3.2 PIR Detector Installation

The second component installed was the PIR detector (D1) which detects vehicles traveling westbound on West Tischer Road. A PIR detector is not mounted on existing structure like the radar detector so a dual 8 ft (2.4 m) u-channel sign post configuration was used. The solar panel is mounted on the top the outer u-channel sign post. Again, the utility truck was used to hold the sign posts while the solar panel bracket, solar panel housing, and PIR sensor were mounted. The PIR sensor is mounted below the solar panel on the inner u-channel sign post. It is slightly tilted in order to only detect vehicles traveling in the westbound lane. Figure 45 shows an image of the utility truck holding the completed PIR detector.



Figure 45: Utility truck holding the PIR detector.

The completed PIR detector was mounted on previously buried 8 ft (2.4 m) u-channel sign posts. Figure 46 shows an image of the installed PIR detector (D1). The second PIR detector (D4) was installed in a similar fashion.



Figure 46: Installed PIR detector.

5.3.3 Blinker Sign Installation

The last components installed were the three blinker signs. The first blinker sign installed was the “CROSS TRAFFIC WHEN FLASHING” blinker sign (S1) located on West Tischer Road. This is a 48 in (121.9 cm) warning sign. This is the largest of the three blinker signs so a three u-channel support system similar to the radar detectors was used. Installation of the blinker sign components was quite simple. Three connections from the solar panel to the sign had to be made: power, solar panel charging, and blinker control. The solar panel was then mounted to the top of the battery bank tube and adjusted to face south. Tapco does not provide an adjustable tilt angle on their solar panels. The lettering of the sign was done by the St. Louis County Sign Shop. Figure 47 shows the installed “CROSS TRAFFIC WHEN FLASHING” blinker sign.



Figure 47: Installed “CROSS TRAFFIC WHEN FLASHING” blinker sign.

Next, the two “VEHICLE APPROACHING WHEN FLASHING” blinker signs (S2 and S3) were installed on Eagle Lake Road. These two signs are 36 in (91.4 cm) warning signs and only need to be supported by two u-channel sign posts. Figure 48 shows the installed “VEHICLE APPROACHING WHEN FLASHING” blinker sign.



Figure 48: Installed “VEHICLE APPROACHING WHEN FLASHING” blinker sign.

Chapter 6: Data Collection

Data collection was completed by an on-site video monitoring system consisting of a Digital Video Recorder (DVR) and two video cameras. Data collection occurred in two phases. In the first phase, vehicle movements were recorded before the installation of the ALWS. Phase I data collection included a time period of 48 days. In the second phase, vehicle movements were recorded after the warning system had been installed at the intersection. Phase II data collection included a time period of 204 days.

6.1 On-Site Video Monitoring System

The on-site video monitoring system was installed on June 2, 2009 by Rocky Olson of Electric Builders Inc. The on-site video monitoring system consists of two Color IR CCD Cameras and a DVR. The specifications of the cameras are:

- 420 line color resolution (day)
- 420 line resolution black & white (night)
- 3.6 mm lens
- Auto iris
- Wall or ceiling mount
- BNC video pig tail connection
- RCA power connection 12 VDC
- Sun shield included.
- Environmentally protected
- -10 ° F to 120 ° F operation

The cameras were configured for motion detection in order to reduce data burden. The time recorded prior to detection (pre-record time) can be adjusted from 0, 2, 4, 6, 8, or 10 seconds. The time after detection occurs (post-record time) can be adjusted to 10 seconds, 30 seconds, 1 minute, 5 minutes, or 10 minutes. The sensitivity of the motion detection can be adjusted between 0-10. The area of motion detection can be adjusted to “All” or “Parts” of the video image. Configurations used in this system are:

Pre-Record Time = 4 seconds

Post-Record Time = 10 seconds

Camera 1 Sensitivity = 6

Camera 2 Sensitivity = 8

Camera 1 Area of Motion = All

Camera 2 Area of Motion = Parts

In order to prevent Camera 2 from being triggered by moving branches near the southeast quadrant of the intersection, the area of detection was set to “Parts”.

Data from these cameras was recorded to a 4-channel DVR. This DVR has two hard drives: HDD-A = 79 GB, HDD-D = 229 GB. When one hard drive is full, the DVR will automatically start recording data on the other hard drive. Data can be downloaded from the

DVR in multiple formats including CD-R, CD-RW, DVD-R, DVD-RW, and USB 2.0. Each recording is time stamped.

6.1.1 Video Layout

The DVR and two video cameras were installed on-site. Figure 49 shows a layout of the intersection and the installed on-site video monitoring system. The first camera was located 592 feet (156.1 m) from the intersection on a utility pole. This camera recorded vehicles traveling westbound on West Tischer Road towards the intersection. The utility pole nearest to the intersection was used to mount a second camera. This camera recorded the vehicle movements through the intersection.

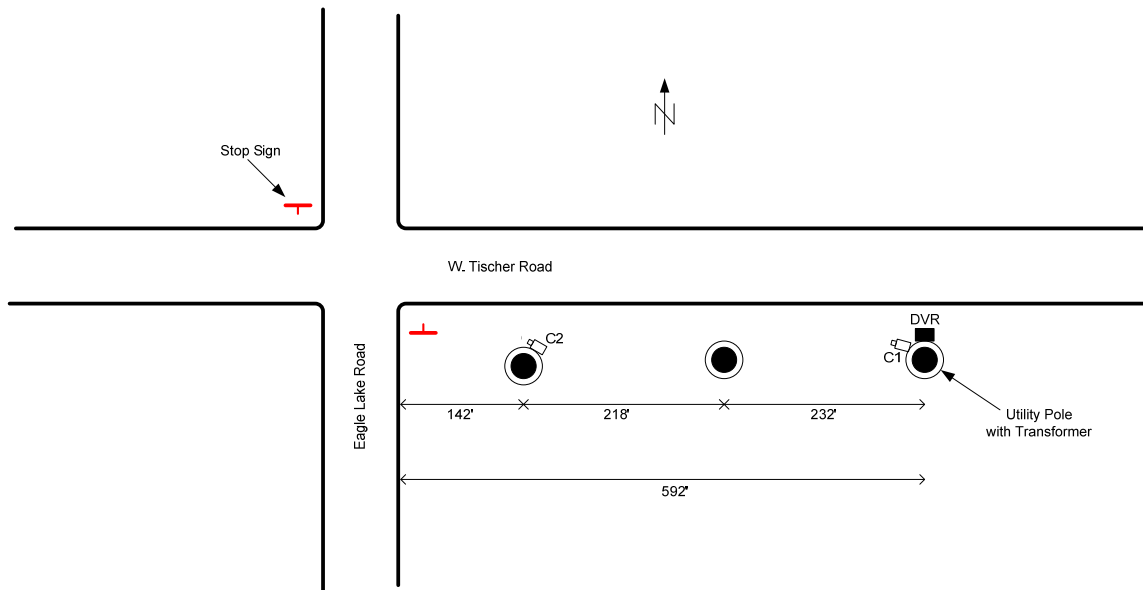

Figure 49: Video intersection layout.

The DVR is mounted in front of the utility pole which C1 is attached to. This is because this pole contains a transformer. A custom DVR cabinet was built by Povolny Specialties. This cabinet is suspended between two u-channel poles in order to raise it above the ground. The cabinet is constructed from aluminum and is NEMA 3R rated which is intended for outdoor use primarily to provide a degree of protection against windblown dust, rain, and sleet; undamaged by ice which forms on the enclosure. The cabinet was modified to contain ventilation holes in order for air to circulate throughout the cabinet. The cabinet is attached to the u-channel poles using sealable screws. The cabinet has a front door that is lockable. Figure 50 displays sample images from both Camera 1 and Camera 2 at the intersection.



Figure 50: Images of a vehicle traveling towards (left) and through (right) the intersection.

6.2 Speed Markers

An important part of the data collected at the intersection is the speed of vehicles traveling westbound towards the intersection on West Tischer Road. Two transverse white lines, referred to as speed markers, and separated by a distance of 150 feet (45.7 m) were installed on the pavement surface on July 9, 2009. The first speed marker is 425 ft (129.5 m) from the intersection. The second speed marker is 575 ft (175.3 m) from the intersection. Speed markers are visible in Figure 50 (left).

Vehicle speeds were measured by counting the number of frames for a vehicle to travel the distance between the speed markers. A computer program captured images of each speed marker before a vehicle was present. These captured images of the speed markers were correlated to the subsequent frames to determine when a vehicle crossed each speed marker. The video cameras used a resolution of 30 frames per second. This measurement method had an accuracy of 1 mph (1.6 km/h). The calculation used the following equations:

$$\frac{1}{30 \frac{\text{frames}}{\text{second}}} = 0.033 \frac{\text{seconds}}{\text{frame}} \quad (30)$$

$$\text{Speed (mph)} = \left(\frac{1 \text{ mile}}{5280 \text{ feet}} \right) \left(\frac{3600 \text{ seconds}}{1 \text{ hour}} \right) \left(\frac{150 \text{ feet}}{(\# \text{ frames}) \times 0.033 \frac{\text{seconds}}{\text{frame}}} \right) \quad (31)$$

6.3 Data Collection

During the summer and fall, data collection was done on-site. A TV monitor was connected to the DVR using an s-video cable in order to navigate the file system on the DVR. A 750 GB external hard drive connected to the DVR via a USB cable was used to download the data. Figure 51 shows an image of on-site data collection set-up. During the winter months, it was found that it was easier to disconnect the DVR from the system and download the data in lab.



Figure 51: On-site data collection.

The DVR used in the video system only allows data to be downloaded in 2 GB portions. Each 2 GB portion takes about 10 minutes to download. A normal day of video data contains around 6 GB worth of data. Instead of downloading every file for each day, a single 8-hour portion of data was collected. An 8-hour portion of video data is approximately 1.5 GB and contains about 400 video files. These 8-hour portions were randomly selected from three different time periods: 12:00AM – 8:00AM, 8:00AM – 4:00PM, or 4:00PM – 12:00PM. Dividing the data collection into portions for each day sped up the data collection process but still provided enough video footage to be analyzed. Since there is limited space on the DVR, data was deleted after downloading.

6.3.1 Phase I Data

During the first phase of data collection, vehicle movements were recorded prior to the installation of the ALWS. Phase I data collection started on July 9, 2009. Video data was recorded until July 13, 2009. On July 14, 2009, the DVR malfunctioned and had to be sent in to Automated Video Systems for repairs. The DVR was fixed and re-installed at the intersection on August 11, 2009. Phase I data collection continued until September 22, 2009. A total of 48 days with 24,280 video files were recorded in Phase I.

6.3.2 Phase II Data

The installation of the ALWS started September 23, 2009. After the installation, a couple of changes to the warning system were made. First, an external LED signaling vehicle detection was placed on the outside of the solar panel housing of the PIR detectors. This allowed the PIR sensors to be easily positioned in order to only detect vehicles traveling in a single lane. Second,

the software in the three blinker signs was altered. This included extending the time that the signs blink after vehicle detection. Finally, it was determined by the St. Louis County traffic engineers S1, the “CROSS TRAFFIC WHEN FLASHING” sign, should be moved closer to the intersection.

Actual Phase II data collection started on November 1, 2009 and ended on May 23, 2010. A total of 204 days with 72,059 video files were recorded. The time between the start of the installation of the ALWS and the start of Phase II data collection was 39 days.

6.4 Vehicle Speed Software Program

The video files collected from the on-site video monitoring system are encoded in a proprietary file format. This means that only the supplied video viewer (Figure 52) can be used to view the video files. This makes analysis of the video files using software very difficult. A vehicle speed software program was developed using Microsoft Visual Studio .NET Visual Basic and LEADTOOLS Document Imaging add-on. The vehicle speed GUI is shown in Figure 53.



Figure 52: Supplied video viewer.

The user has the option of either analyzing a single video file, a single directory with multiple video files, or multiple directories with multiple video files. The vehicle speed GUI begins by opening a video file using the supplied video viewer. The vehicle speed software program uses a frame-by-frame approach to measure vehicle speed.

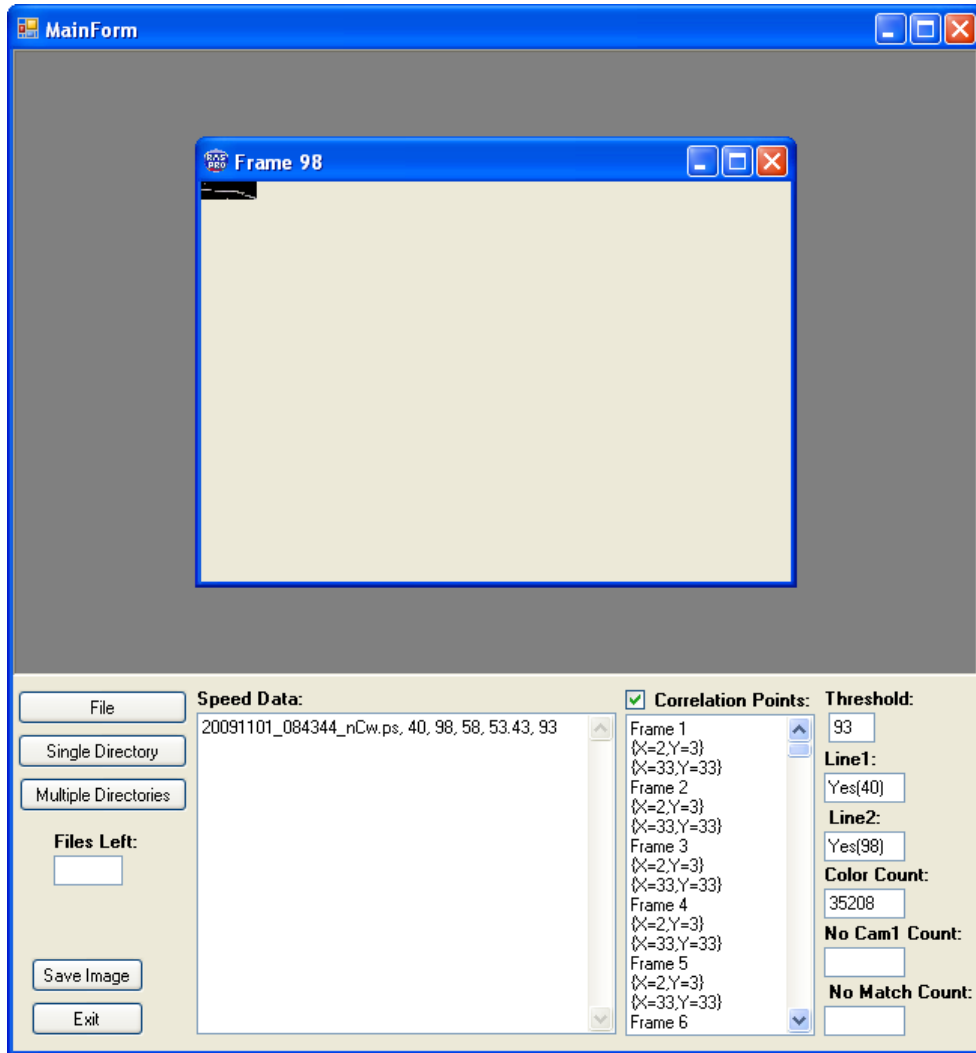

Figure 53: Vehicle speed GUI.

When an image exists in the Cam 1 window of the supplied video viewer, the software program crops a color image of speed marker 1 and speed marker 2, converts them to black and white images, and saves them. A correlation filter is used to compare the saved black and white image of speed marker 1 to subsequent frames. When a vehicle crosses speed marker 1 and the correlation result is less than a specified threshold, that image is saved and the frame number is recorded. Figure 54 shows the saved black and white image of speed marker 1 (left) and the black and white image of speed marker 1 when a vehicle crossed it (right). Images shown in Figure 54 are enlarged by 400 percent.



Figure 54: Black and white images of speed marker 1.

After a vehicle crosses speed marker 1, a second correlation filter is used to compare the saved black and white image of speed marker 2 to subsequent frames. When a vehicle crosses speed marker 2 and the correlation result is less than a specified threshold, that image is saved and the frame number is recorded. Figure 55 shows the saved black and white image of speed marker 2 (left) and the black and white image of speed marker 2 when a vehicle crossed it (right). Images shown in Figure 55 are enlarged by 400 percent.



Figure 55: Black and white images of speed marker 2.

Using Equation 31 and the frame count it takes a vehicle to cross both speed markers, a value for speed can be calculated with 1 mph (1.6 km/h) accuracy. After a successful speed calculation, the name of the file, frame count 1, frame count 2, speed, and threshold are recorded in a comma separated line in both the vehicle speed GUI and a text file. The vehicle speed software program was modified in order to measure vehicle speed at night, during snow covered roads, and account for shifting of camera angles.

Chapter 7: Data Analysis

The video data analysis consisted of three movements. They were speeds of vehicles on the westbound main approach, time a vehicle was stopped at a stop sign or wait time, and vehicles that rolled through a stop sign or roll-throughs. The other data analysis consisted of mail-in and on-site surveys. A z-test was conducted on each set of analyzed video data samples and the complete z-test analysis can be found in Appendix C.

A before-and-after crash analysis was not conducted for this project. Because the evaluation of the warning system only lasted one year and was conducted at a low-volume intersection, accidents are rare and it is difficult to statistically justify crash data in this short time period. Instead, data analysis focused on the changes in driver behavior.

7.1 Major Approach Speed

Vehicle speeds were measured during three scenarios. The first scenario was a measurement of vehicle speeds during the before and after installation periods. The second scenario was a measurement of vehicle speeds in the after installation period when blinker sign S1, "CROSS TRAFFIC WHEN FLASHING", was not activated, or no vehicle conflict present. And the third scenario was a measurement of vehicle speeds in the after installation period when S1 was activated, or a vehicle conflict was present.

The computer program used to measure vehicle speeds occasionally undercounted the number of frames it took for a vehicle to travel between both speed markers. Possible explanations for undercounting the number of frames include shadows, displaced camera angles, deterioration of the speed markers, and periods when the speed markers were covered by snow. Undercounting video frames resulted in vehicles speeds measured in excess of 100 mph (160.9 km/h). Assuming that vehicle speeds greater than 100 mph (160.9 km/h) were unrealistic, these outliers were eliminated from the data analysis.

Of the 24,280 video files collected before the installation of the ALWS, 6,191 vehicles were processed by the vehicle speed software program. Figure 56 shows the vehicle speed distribution before installation of the warning system. The average, median, and standard deviation were 46.3 mph (74.5 km/h), 46.3 mph (74.5 km/h), and 9.8 mph (15.8 km/h), respectively.

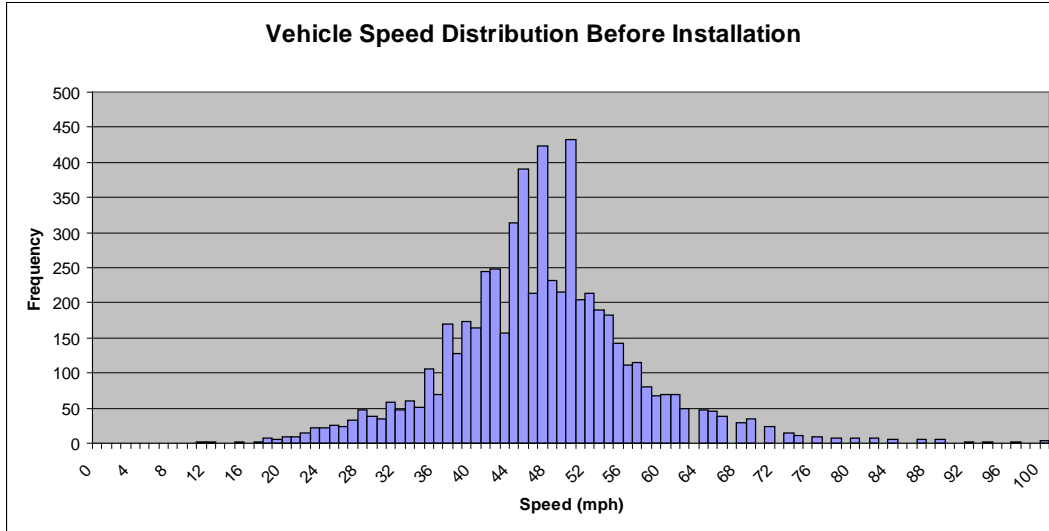

Figure 56: Vehicle speed distribution before installation.

Of the 62,341 video files collected after the installation of the warning system, 9,931 vehicles were processed by the software program. Figure 57 shows the vehicle speed distribution after installation of the warning system. The average, median, and standard deviation were 47.1 mph (75.8 km/h), 47.0 mph (75.6 km/h), and 12.0 mph (19.3 km/h), respectively.

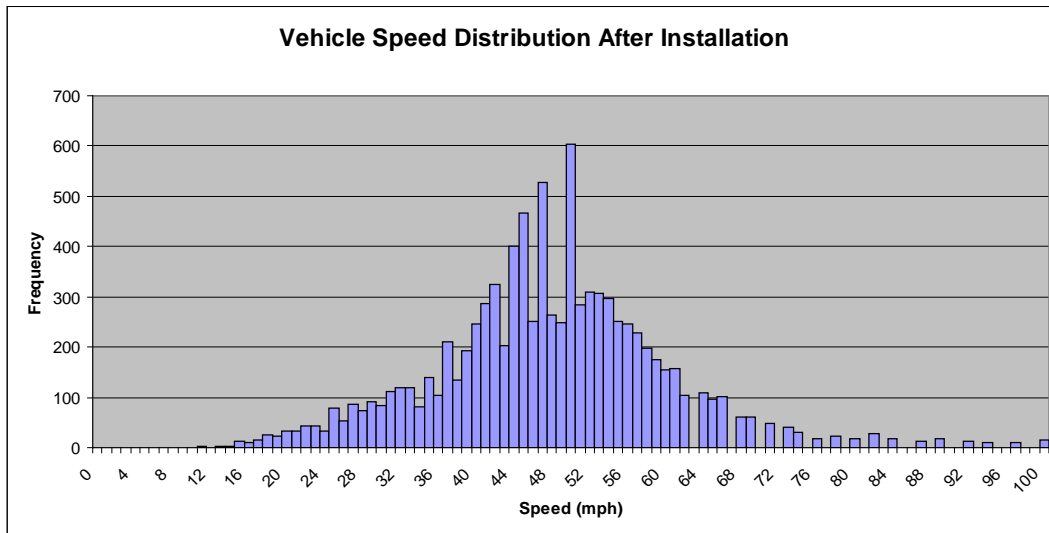

Figure 57: Vehicle speed distribution after installation.

Vehicle speeds were analyzed in four different categories. First, average speeds were calculated for vehicles traveling at daytime or nighttime. Second, average speeds were calculated for vehicles traveling during the morning peak traffic periods (7:00AM – 9:00PM), afternoon peak traffic periods (3:00PM – 5:00PM), and off-peak traffic periods. Determination of the morning and afternoon peak traffic periods was completed by observing the traffic patterns. Third, average speeds were calculated for vehicles traveling either during the weekday or weekend. A weekday was defined as Tuesday, Wednesday, or Thursday. A weekend was defined

as Saturday or Sunday. And fourth, average speeds were calculated on a monthly basis. Holidays were eliminated from each average speed comparison. Table 8 summarizes the comparison of average speeds before and after installation of the warning system using these four categories.

The comparison of average speeds before and after the installation of the warning system showed that vehicle speeds only decreased for nighttime. It should be noted that S1 was a used sign and the LEDs were observed to be significantly dimmer than the LEDs on the two new signs S2 and S3. Because the LEDs were dimmer on S1, they were much harder to see during the day than at night. This could be a reason why average vehicle speeds only decreased at nighttime after the installation of the warning system. In all other categories excluding monthly averages, the average increase of speed was 1.0 mph (1.7 km/h). A z-test was conducted to see if there is a significant difference between the sample means of vehicle speeds before and after the installation of the warning system. Using a 95 percent confidence interval, significant differences between before and after vehicle speeds were observed.

Table 8: Comparison of Average Speeds Before and After Installation

Before Installation Average Speeds (mph)		After Installation Average Speeds (mph)	
Daytime	46.1	Daytime	47.7
Nighttime	49.1	Nighttime	44.9
AM Peak	47.0	AM Peak	47.1
PM Peak	44.6	PM Peak	46.9
Off Peak	46.4	Off Peak	47.1
Weekday	46.2	Weekday	47.3
Weekend	46.3	Weekend	46.6
July	46.3	November	48.1
August	46.1	December	43.9
September	46.7	January	44.9
		February	48.4
		March	47.3
		April	49.8
		May	46.3

Vehicle speeds were also analyzed in the after installation period when the warning system was activated, indicating a vehicle conflict, or not activated, indicating no vehicle conflict. The activated condition, or conflict, was defined as the time when S1 was activated and a driver on the main approach observed S1 flashing. The not activated condition, or no conflict, was defined as when S1 was not activated and a driver on the main approach did not observe S1 flashing. Table 9 summarizes these comparisons using the same four categories as above.

In all cases, vehicle speed decreased in the conflict condition with an average decrease of 4.5 mph (7.2 km/h). Based on a z-test, significant differences in vehicle speeds during a no conflict and conflict situation were observed. This decrease in speed translates to a 1.2 second

difference in time from the moment the driver sees the blinking sign to entering the intersection, thus increasing the reaction time. Since the blinking sign caused the decrease in speed, it also indicates that the driver is informed that a vehicle is crossing the intersection. This is important, especially on rural, low-volume, high-speed roads where drivers often pay less attention than in higher traffic areas.

Table 9: Comparisons of No Conflict and Conflict Average Speeds After Installation

No Conflict (mph)		Conflict (mph)	
Daytime	47.7	Daytime	43.4
Nighttime	44.9	Nighttime	41.2
AM Peak	47.1	AM Peak	40.9
PM Peak	46.9	PM Peak	45.9
Off Peak	47.2	Off Peak	42.4
Weekday	47.3	Weekday	42.1
Weekend	46.7	Weekend	40.8
November	48.1	November	45.6
December	43.9	December	38.6
January	45.0	January	36.3
February	48.4	February	46.8
March	47.4	March	43.7
April	49.8	April	41.6
May	46.3	May	44.4

7.2 Intersection Wait Times and Roll-Throughs

Intersection wait time is defined as the amount of time it took a vehicle to enter the intersection after it came to a complete stop at either stop sign on Eagle Lake Road. Roll-throughs were defined as a vehicle traveling through the intersection without coming to a complete stop at the stop sign. Intersection wait time and roll-throughs were computed by random sampling and manually observing the video data. Average intersection wait time and roll-throughs are compared before and after the installation of the warning system. Intersection wait time is compared in three different categories. They are total average, daytime average, and nighttime average. Table 10 summarizes these comparisons.

A significant observation was that roll-throughs actually increased after the installation of the warning system (from 13% to 24%). This could be explained by the warning system conditioning drivers to rely on the warning system rather than still use their own judgment. A similar driver behavior was observed in the past studies [17, 18]. Although this is a negative but expected effect, it implies that drivers are in fact understanding and using the additional information provided by the warning system.

Regarding wait times, a marginal increase was shown in total and daytime wait times after installation and a marginal decrease in nighttime wait time compared to before installation.

The result of the z-test confirmed that there is no significant difference in intersection wait times before and after installation of the new warning system.

Table 10: Comparisons of Average Intersection Wait Time and Total Roll-Throughs Before and After Installation

	Total Average Wait Time (seconds)	Daytime Average Wait Time (seconds)	Nighttime Average Wait Time (seconds)	Total Roll-Throughs
Before Installation	3.3	3.2	3.6	11 (13%)
After Installation	3.6	3.8	2.9	40 (24%)

To explore wait times further, average wait times after installation of the warning system were compared for two cases. They were when S2 and S3 were flashing, indicating a vehicle conflict, and when they were not flashing, indicating no vehicle conflict. During a vehicle conflict, S2 and S3 were flashing and a vehicle on the minor approach was waiting to enter the intersection. During no vehicle conflict, S2 and S3 were not flashing and a vehicle on the minor approach was waiting to enter the intersection. Table 11 summarizes these observations.

The wait time increased when S2 and S3 were flashing with an average increase of 5.4 seconds. The result of a z-test confirmed that there is a significant difference in intersection wait times during a no conflict and conflict situation after the installation of the warning system. Similar to the increase in roll-throughs before and after the installation of the warning system, this shows that drivers are using the additional information provided by warning system. In this case, drivers are using the provided information to assist in accepting a safe gap in the westbound traffic stream.

Most significantly, there were no roll-throughs observed when S2 and S3 were flashing. Roll-throughs only occurred during those periods of no vehicle conflicts. This means that the new warning system was able to completely stop roll-throughs under all vehicle conflict conditions.

Table 11: Comparisons of No Conflict and Conflict Average Wait Time and Total Roll-Throughs After Installation

	Total Average Wait Time (seconds)	Daytime Average Wait Time (seconds)	Nighttime Average Wait Time (seconds)	Total Roll-Throughs
No Conflict	2.1	2.2	1.9	40 (24%)
Conflict	7.1	7.0	8.0	0

7.3 Mail-In Survey

On June 8, 2010, a mail-in survey was sent to local residents living within a half-mile radius of the intersection. This survey was printed on pre-stamped postcards to encourage those residents to respond. On the back side of the postcard was a short explanation of the purpose of the mail-in survey with five short questions. Figure 58 displays the mail-in survey postcard.

Ryan Weidemann
 University of Minnesota-Duluth
 10 University Drive, MWAH 271
 Duluth, MN 55812

Ryan Weidemann
 University of Minnesota-Duluth
 10 University Drive, MWAH 271
 Duluth, MN 55812

<p>Over the past 7 months you may have noticed additional signs at the intersection of West Tischer Road and Eagle Lake Road. A dynamic intersection warning system was installed by the University of Minnesota-Duluth (UMD). The warning system was designed to provide additional information to assist drivers. To measure the effectiveness of the warning system, please take the time to answer these short survey questions and mail the pre-stamped postcard back to UMD. Thank you for your time.</p> <p>Questions? Contact Ryan Weidemann at 218-393-3070.</p>	<p>1. On average, how many times a day do you travel through the intersection of West Tischer Road and Eagle Lake Road?</p> <p><input type="checkbox"/> 0 <input type="checkbox"/> 1 <input type="checkbox"/> 2 <input type="checkbox"/> 3 or more</p>										
	<p>2. How much do you agree with the following statements:</p> <table border="0"> <tr> <td></td> <td style="text-align: center;">Strongly</td> <td></td> <td></td> <td style="text-align: center;">Strongly</td> </tr> <tr> <td></td> <td style="text-align: center;">Agree</td> <td style="text-align: center;">Agree</td> <td style="text-align: center;">Disagree</td> <td style="text-align: center;">Disagree</td> </tr> </table>		Strongly			Strongly		Agree	Agree	Disagree	Disagree
		Strongly			Strongly						
		Agree	Agree	Disagree	Disagree						
<p>The warning system is easy to understand</p> <p style="text-align: center;"><input type="checkbox"/> <input type="checkbox"/> <input type="checkbox"/> <input type="checkbox"/></p> <p>The warning system improved the safety of the intersection</p> <p style="text-align: center;"><input type="checkbox"/> <input type="checkbox"/> <input type="checkbox"/> <input type="checkbox"/></p> <p>The warning system could be used at other intersections</p> <p style="text-align: center;"><input type="checkbox"/> <input type="checkbox"/> <input type="checkbox"/> <input type="checkbox"/></p>											
<p>3. How would you rate the overall effectiveness of the warning system?</p> <p><input type="checkbox"/> Excellent <input type="checkbox"/> Good <input type="checkbox"/> Fair <input type="checkbox"/> Poor</p>											
	<p>4. Additional comments.</p> <p>_____</p> <p>_____</p> <p>_____</p>										

Figure 58: Mail-in survey.

There were 98 mail-in surveys distributed. Two were returned because of an unknown address leaving 96 mail-in surveys that reached the local residents. A total of 46 (47.9%) surveys were completed and returned. One person conducted the mail-in survey over the phone and one letter written by a resident was received. The results of the mail-in survey are displayed in Table 12.

From the responses received, 77 percent frequent the intersection at least once a day. A strong majority, 89 percent, either strongly agreed or agreed that the warning system was easy to understand. Another strong majority, 81 percent, either strongly agreed or agreed that the warning system has improved the safety of the intersection. A total of 83 percent strongly agreed or agreed that the warning system could be used at other intersections. And 86 percent rated the overall effectiveness of the warning system as either excellent, good, or fair.

Table 12: Mail-In Survey Results

Question	0	1	2	3+
1. On average, how many times a day do you travel through the intersection of West Tischer Road and Eagle Lake Road?				
	10 (23%)	7 (16%)	10 (23%)	17 (38%)
2. How much do you agree with the following statements:	Strongly Agree	Agree	Disagree	Strongly Disagree
The warning system is easy to understand?	18 (42%)	20 (47%)	5 (11%)	0 (0%)
The warning system improved the safety of the intersection?	19 (44%)	16 (37%)	3 (7%)	5 (12%)
The warning system could be used at other intersections?	20 (46%)	16 (37%)	3 (7%)	4 (10%)
3. How would you rate the overall effectiveness of the warning system?	Excellent	Good	Fair	Poor
	17 (40%)	15 (35%)	5 (11%)	6 (14%)

Comments from the mail-in survey were sorted into four categories: positive, negative, suggestive, and irrelevant. A comment classified as positive praises the warning system. A comment classified as negative voices concerns about the warning system. The suggestive category is used to categorize comments made by residents who recommend modifications to the warning system. After each comment, the frequency of traveling through the intersection per day by commenter is displayed in parentheses. This was done to place more weight on comments made by residents who travel through the intersection more frequently. Below are three sampled comments from each category written by residents on the mail-in survey.

Positive

- It’s about time safety devices were installed. It is an intersection that causes anxiety when crossing. (3+)
- One of the most effective traffic tools I have seen. *Will save a life!* (1)
- The warning system is effective but I’ve seen vehicles run the stop sign because the lights are not flashing. (3+)

Negative

- Better if drivers understood it better. Visitors have asked how it works, so it takes getting used too. (3+)

- The system is not totally consistent. It also teaches new drivers to rely on system not sight. (3+)
- It doesn't always work and now people depend on it. They barely stop if not flashing. 1 accident since installed. 4 way stop would be safer. (3+)

Suggestive

- Removing the speed limit increase sign (when approaching from the east) would also help. It tells drivers they can speed up past hill. (3+)
- We do not have access to data, so therefore do not know if safety or effectiveness is improved. Lower speed limit to 40 mph and increase law enforcement. (2)
- It flashes for oncoming traffic from one direction, the sign should say that, but instead says just oncoming traffic. An accident occurred there 2 weeks ago, if sign was working then. (3+)

Irrelevant

- Presume they help, but never saw them activated. (0)
- I've only gone that way a few times and have not seen it work. (0)
- I wish I could be more help. (0)

Four examples of a completed mail-in survey can be found in Appendix D. The letter written by a resident can be found in Appendix E. A complete list of comments written by residents on the mail-in survey can be found in Appendix F.

7.4 On-Site Survey

On June 30, 2010, an on-site survey was also performed at the intersection. This survey had two purposes. First, to survey residents who may not have received a mail-in survey. And second, to engage in conversations with drivers about the warning system. The latter reason proved to very valuable because the research team learned information that was not gathered from the mail-in survey.

The on-site survey was performed at two different times on June 30th, 2010: 8:20AM – 9:25AM and 4:20PM – 5:20PM. These time periods were selected to survey the morning and afternoon peak hour traffic. The questions for this survey were identical to the mail-in survey and performed by two members of the research team. One person standing on the north approach surveying southbound vehicles, and another person on the south approach surveying northbound vehicles. Vehicles were approached when they stopped at the stop signs. A total of 29 vehicles were approached and 14 drivers participated in the survey. Comments were categorized into three categories. They are positive, negative, and suggestive. The results of the on-site survey are summarized in Table 13. The results were similar to the mail-in survey.

Table 13: On-Site Survey Results

Question	0	1	2	3+
1. On average, how many times a day do you travel through the intersection of West Tischer Road and Eagle Lake Road?				
	2 (14%)	2 (14%)	0 (0%)	10 (72%)
2. How much do you agree with the following statements:	Strongly Agree	Agree	Disagree	Strongly Disagree
The warning system is easy to understand?	2 (14%)	11 (79%)	1 (7%)	0 (0%)
The warning system improved the safety of the intersection?	4 (29%)	6 (43%)	3 (21%)	1 (7%)
The warning system could be used at other intersections?	3 (21%)	8 (58%)	3 (21%)	0 (0%)
3. How would you rate the overall effectiveness of the warning system?	Excellent	Good	Fair	Poor
	0 (0%)	11 (79%)	1 (7%)	2 (14%)

Below are two sample comments from each category voiced by participants during the on-site survey.

Positive

- A good warning system if it is reliable, a bad warning system if it doesn't work all the time.
- A driver's brother who is a policeman from Iowa saw the warning system and thought it was a great idea. He said he had not seen anything like it.

Negative

- Another driver mentioned the problem of the hill on Eagle Lake Road. She said that people are starting to rely only on the lights and sometimes they do not work
- When the signs are working the system is neat. The driver questions the intelligence of other drivers to understand how the system works. He told his son who is a new driver to ignore the flashing lights and just use the stop signs to look for vehicles. He is worried his son will eventually rely solely on the blinking signs and not his vision.

Suggestive

- Larger and brighter lights like the yellow ball flashers on Highway 53.
- Worried about young drivers trusting the sign too much. Should put in a 4-way stop like the one on West Tischer Road and Arnold Road.

A common theme of the mail-in and on-site survey comments was that residents are concerned that motorists will start treating the warning system like a traffic signal and disregard the stop sign and roll-through the intersection when the sign is not flashing. This concern was validated by the intersection wait time and roll-through data and is an unanticipated negative effect of the warning system. The majority of residents believe the warning system improves

safety, but at the same time are concerned of potential crashes caused by roll-throughs. A complete list of comments from the on-site survey can be found in Appendix G.

Chapter 8: Conclusions and Future Recommendations

8.1 Conclusions

This report presented the results of a two year study on the development and evaluation of an Advanced LED Warning System (ALWS). The ALWS was shown to positively change driver's behavior at a low-volume, rural through/stop intersection with sight restrictions caused by a vertical curve. Presently, there are several intersection countermeasures that have been proven to be effective at improving intersection safety performance but are expensive and cannot be readily justified at low-volume, rural intersections. The ALWS was designed as a low-cost, mobile warning system specifically for these types of intersections. The ALWS uses non-intrusive vehicle sensors and LED blinker signs that efficiently use electrical power supplied entirely by renewable energy, which requires no connections to local power grid. All communication between vehicle detectors and blinker signs are transmitted wirelessly increasing the mobility of the system while eliminating the problems associated with buried wires.

To study the effectiveness of the ALWS, driver behavior and a survey of local residents and frequent users of the intersection were analyzed. Driver behavior was derived from analysis of collected video data and included three movements: speeds of vehicles on the westbound main approach, intersection wait time, and roll-throughs. After installation of the warning system, vehicle speed decreased during a conflict situation with an average decrease of 4.5 mph (7.2 km/h), a 5.4 second increase in average intersection wait time was observed during a conflict situation, and roll-throughs were eliminated during a conflict situation. A negative but expected effect of the warning system was the increase in roll-throughs during a no conflict situation after the installation of the warning system. According to the mail-in and on-site survey results, a strong majority of respondents believed that the warning system is easy to understand, improves the safety of the intersection, and is effective. However, several respondents also noticed the increase in roll-throughs when a no conflict situation arises. If the increase in roll-throughs is addressed in future designs, the authors believe that the ALWS can be an effective, low-cost system for reducing crashes at rural, through/stop intersections.

8.2 Future Recommendations

To address the increase in roll-throughs for vehicles on minor approaches, the research team recommends three potential solutions. First, the stop signs on the minor approaches could be integrated with flashing LEDs. Both the stop signs and warning signs could flash simultaneously, making it clear to drivers that the stop signs should not be ignored. This suggestion is based on the study that flashing LED stop signs have been shown to be effective at reducing roll-throughs [19]. Second, stop bars, which are not currently used at the intersection, could be installed. The width of the stop bars could be 36 inches (91.4 cm) to make them more noticeable to drivers. Lastly, an alternate location of the warning signs S2 and S3 could be considered. The original design of the ALWS placed the warning signs on the east and west legs of West Tischer Road. Drivers would then have to stop at the intersection and look in both directions of oncoming traffic to obtain the additional information provided by the warning signs. This alternate location of the warning signs was not implemented.

After the installation of the warning system an accident did occur at the intersection. This accident was a right-angle crash involving a SUV traveling north on Eagle Lake Road and a motorcycle traveling east on West Tischer Road. Contributing factors that led to the accident,

according to the video footage of the accident, were the disregard of a traffic control device and failure to yield the right away; both committed by the driver of the SUV. The warning system was found to be operational during the accident. Since the study of the ALWS only lasted one year, a before-and-after crash analysis was not conducted. To gather sufficient crash data, especially for a low-volume intersection, a 5-10 year crash analysis period would be necessary.

Finally, to strengthen findings of this study, the warning system could be implemented at multiple locations. Installation at a horizontal curve for example, would be extremely beneficial to the overall study of the effectiveness of warning system. This, of course, requires additional funding and an extended study period.

References

- [1] Minnesota Department of Transportation, *2006 and 2008 Intersections Green Sheets*. Minnesota Department of Transportation, State Aid Traffic Safety Resource, (Accessed July 19, 2010), http://www.dot.state.mn.us/stateaid/sa_traffic_safety.html.
- [2] H. Preston, and R. Storm. *Mn/DOT Minnesota Comprehensive Highway Safety Plan (CHSP)*. Minnesota Department of Transportation, St. Paul, MN, 2004.
- [3] A. Al-Kaisy. *Static Warning Signs for Occasional Hazards: A Synthesis of Research and Practice*. Western Transportation Institute, Montana State University. Bozeman, MT, 2006.
- [4] J.L. Gattis. *Cross Traffic Signing for STOP Signs*, No. 960073. Transportation Research Board 75th Annual Meeting, January, Washington, D.C., 1996.
- [5] D.L. Picha, C.E. Schuckel, J.A. Parham, and C.T. Mai. *Traffic Control Devices at Two-Way Stop-Controlled Intersections*, Rep. No. 1374-1F. Texas Transportation Institute, College Station, TX. 1996.
- [6] Minnesota Department of Transportation, *2007 Traffic Volume Maps*, (Accessed November 26, 2009), http://www.dot.state.mn.us/traffic/data/maps/trafficvolume/2007/cities_over_5000/duluth5.pdf.
- [7] Google Maps, (Accessed December 10, 2010), <http://maps.google.com>.
- [8] Tapco, *R1-1 Solar Blinker Signs*, (Accessed December 16, 2009), <http://www.tapconet.com/common/productbrochurehandler.ashx?id=0bb20288-3a5b-4889-b545-4a13be2f0e08>.
- [9] National Renewable Energy Laboratory, *July PV Solar Radiation Map*, (Accessed November 26, 2009), http://www.nrel.gov/gis/images/map_pv_us_july_may2004.jpg.
- [10] Carmanah, *CT-11, CT-22, CT-32 Solar Modules*, (Accessed July 10, 2009), <http://www.solarforrv.com/commonfiles/libraries/docs/specsheets/CTI-11-22-32.pdf>.
- [11] BP Solar, *SX320, 20 Watt Photovoltaic Module*, (Accessed July 10, 2009), http://www.bp.com/liveassets/bp_internet/solar/bp_solar_usa/STAGING/local_assets/downloads_pdfs/pq/SX320M_J_D_01_10.pdf.
- [12] Technoworld Components CC, (Accessed June 22, 2009), <http://www.technoworld.co.za/Solar.pdf>.
- [13] AeroComm Inc., *AC4790 900 MHz Transceiver User Manual, Version 1.8*, (Accessed October 10, 2010), <http://www.lairdtech.com/Products/Wireless-M2M-and-Telematics-Solutions/Proprietary-Radio-Modules/>.

- [14] Microchip, *PIC16F631/677/685/687/689/690 Data Sheet*, (Accessed October 10, 2010), <http://ww1.microchip.com/downloads/en/DeviceDoc/41262C.pdf>.
- [15] Banner Engineering, *R-Gage QT50RAF Sensor*, (Accessed September 14, 2009), <http://info.bannersalesforce.com/xpedio/groups/public/documents/literature/135460.pdf>.
- [16] Kyocera, *Installation Manual for the KC-Series of Solar Photovoltaic Power Modules*, (Accessed August 24, 2009), <http://www.kyocerasolar.com/pdf/specsheets/KC35-120Install.pdf>.
- [17] P.D. Pant, Y. Park, S.V. Neti, and A.B. Hossain. "Comparative Study of Rural Stop-Controlled and Beacon-Controlled Intersections." *Transportation Research Record*, No. 1692, 1999, pp. 164–172.
- [18] G.G. Schultz, and E.S. Talbot. "Advance Warning Signals: Long-Term Monitoring Results." *Transportation Research Record*, No. 2122, 2009, pp. 27–35.
- [19] T.J. Schultz, P.J. Carlson, and H.G. Hawkins. "Field Evaluations of Warning and Regulatory Signs with Enhanced Conspicuity Properties." *Transportation Research Record*, No. 1862, 2004, pp. 64–76.

Appendix A: Charge Controller Installation Instructions







Morningstar SunSaver-20L Solar Charge Controller Installation Instructions

- 1) Mount the SunSaver-20L to a vertical surface.
- 2) Make sure the PV and load currents will not exceed the ratings of the SunSaver-20 model being installed.
- 3) Connect the BATTERY first.
- 4) Connect the SOLAR PANEL next. The green LED indicator will light if sunlight is present.
- 5) Connect the LOAD last. If the red LED indicator lights, the battery capacity is low (below 11.5V) and should be charged before completing the system installation.
- 6) The controller is shipped with a jumper installed. This sets the controller for charging SEALED lead acid batteries. If a FLOODED battery is being used, simply remove the jumper.
- 7) For most effective surge protection, it is recommended that the battery negative conductor be properly grounded.

Genasun GV-4 Solar Charge Controller Installation Instructions:

- 1) Mount the GV-4 to a vertical surface.
- 2) Connect the BATTERY first. The LED should blink once every 8-10 seconds once the battery is connected.
- 3) Connect the SOLAR PANEL next. If there is enough light on the solar panel to charge the battery, the LED will blink green.
- 4) Do not connect the solar panel ground to system ground.

Genasun GV-4 Solar Charge Controller Run/Charge LED Indication:

- 1) Standby. The battery is connected properly and charging will begin when the solar panel power is available (8-10 seconds between blinks).
LED: 
- 2) Charging. With less current than about 1.5A (faster blinking).
LED: 
- 3) Charging. With more current than about 1.5A (longer blinks).
LED: 
- 4) Current Limit. The GV-4 is charging the battery with 4A and the panel could probably produce more power (long blink, then short).
LED: 
- 5) Battery Charged.
LED: 
- 6) Over Temperature. The GV-4 internal temperature is too high (sets of 2 blinks).
LED: 

7) Overload. The GV-4 has been overloaded. This could be caused by changing the solar panel connections while the GV-4 is operating (sets of 3 blinks).

LED: ●●● ●●● ●●● ●●● ●●●

8) Battery Voltage Too Low. The GV-4 cannot begin charging due to low battery voltage. IF the nominal battery voltage is correct (12V), charge the battery by some other means before use (set of 4 blinks).

LED: ●●●● ●●●● ●●●● ●●●● ●●●●

9) Battery Voltage Too High. If the nominal battery voltage is correct (12V), check the functioning of other chargers that may be connected to the system (set of 5 blinks).

LED: ●●●●● ●●●●● ●●●●● ●●●●● ●●●●●

10) Panel Voltage Too High. Only 12V nominal solar panels may be used with the GV-4 (set of 6 blinks).

LED: ●●●●●● ●●●●●● ●●●●●● ●●●●●● ●●●●●●

Appendix B: Tapco Installation Instructions

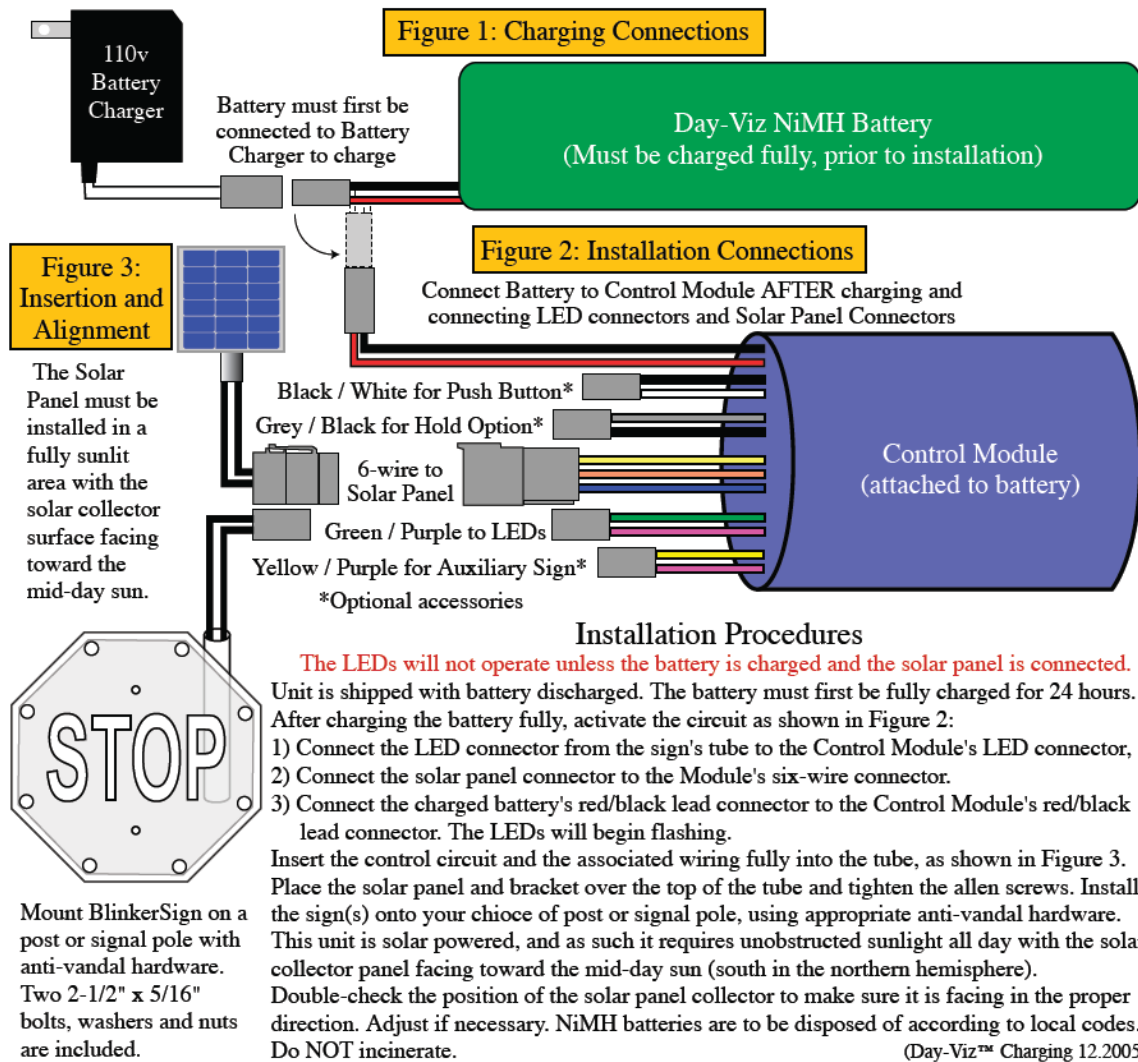

Appendix C: Z-Test Calculations

Vehicle Speeds Before (μ_1) and After (μ_2) Installation

Period	Sample Size (n)	Mean (\bar{X})	Standard Deviation (σ^2)
Before Installation	5990	46.3	9.8
After Installation	9222	47.1	12.0

Hypothesis:

Null: No significant difference in speed

$$H_0: \mu_2 - \mu_1 = 0 \rightarrow \mu_2 = \mu_1$$

Alternate: Significant difference in speed

$$H_1: \mu_2 - \mu_1 \neq 0 \rightarrow \mu_2 \neq \mu_1$$

Test Statistic:

$$z = \frac{\bar{X}_2 - \bar{X}_1}{\sqrt{\frac{\sigma_2^2}{n_2} + \frac{\sigma_1^2}{n_1}}} = \frac{47.1 - 46.3}{\sqrt{\frac{12.0}{9222} + \frac{9.7}{5990}}} = \frac{0.8}{\sqrt{0.0013 + 0.0016}} = \frac{0.8}{\sqrt{0.0029}} = \frac{0.8}{0.054} = 14.8$$

Decision Rule:

Confidence Level	Lower Critical Value	Upper Critical Value
95%	-1.96	1.96

Reject null hypothesis if $z \leq$ lower critical value or $z \geq$ upper critical value.

$$z = 14.8 \geq \text{upper critical value}$$

REJECT null hypothesis. Therefore, there is a significant difference in speed.

The two-tailed P value is less than 0.0001 for $z = 14.8$. By conventional criteria, this difference is considered to be extremely statistically significant.

Vehicle Speeds Conflict (μ_1) and No Conflict (μ_2) After Installation

Period	Sample Size (n)	Mean (\bar{X})	Standard Deviation (σ^2)
Conflict	38	43.0	6.4
No Conflict	9194	47.1	12.0

Hypothesis:

Null: No significant difference in speed

$$H_0: \mu_2 - \mu_1 = 0 \rightarrow \mu_2 = \mu_1$$

Alternate: Significant difference in speed

$$H_1: \mu_2 - \mu_1 \neq 0 \rightarrow \mu_2 \neq \mu_1$$

Test Statistic:

$$z = \frac{\bar{X}_2 - \bar{X}_1}{\sqrt{\frac{\sigma_2^2}{n_2} + \frac{\sigma_1^2}{n_1}}} = \frac{47.1 - 43.0}{\sqrt{\frac{12.0}{9194} + \frac{6.4}{38}}} = \frac{4.1}{\sqrt{0.0013 + 0.17}} = \frac{4.1}{\sqrt{0.1713}} = \frac{4.1}{0.41} = 10.0$$

Decision Rule:

Confidence Level	Lower Critical Value	Upper Critical Value
95%	-1.96	1.96

Reject null hypothesis if $z \leq$ lower critical value or $z \geq$ upper critical value.

$$z = 10.0 \geq \text{upper critical value}$$

REJECT null hypothesis. Therefore, there is a significant difference in speed.

The two-tailed P value is less than 0.0001 for $z = 10.0$. By conventional criteria, this difference is considered to be extremely statistically significant.

Vehicle Wait Time Before (μ_1) and After (μ_2) Installation

Period	Sample Size (n)	Mean (\bar{X})	Standard Deviation (σ^2)
Before	69	3.3	2.9
After	126	3.6	4.6

Hypothesis:

Null: No significant difference in wait time

$$H_0: \mu_2 - \mu_1 = 0 \rightarrow \mu_2 = \mu_1$$

Alternate: Significant difference in wait time

$$H_1: \mu_2 - \mu_1 \neq 0 \rightarrow \mu_2 \neq \mu_1$$

Test Statistic:

$$z = \frac{\bar{X}_2 - \bar{X}_1}{\sqrt{\frac{\sigma_2^2}{n_2} + \frac{\sigma_1^2}{n_1}}} = \frac{3.6 - 3.3}{\sqrt{\frac{4.6}{126} + \frac{2.9}{69}}} = \frac{0.3}{\sqrt{0.037 + 0.042}} = \frac{0.3}{\sqrt{0.079}} = \frac{0.3}{0.28} = 1.1$$

Decision Rule:

Confidence Level	Lower Critical Value	Upper Critical Value
95%	-1.96	1.96

Reject null hypothesis if $z \leq$ lower critical value or $z \geq$ upper critical value.

$$\text{lower critical value} \leq z = 1.1 \leq \text{upper critical value}$$

ACCEPT null hypothesis. Therefore, there is no a significant difference in vehicle wait time.

The two-tailed P value equals 0.2713. By conventional criteria, this difference is considered to be not statistically significant.

Vehicle Wait Time Conflict (μ_1) and No Conflict (μ_2) After Installation

Period	Sample Size (n)	Mean (\bar{X})	Standard Deviation (σ^2)
Conflict	39	7.1	6.8
No Conflict	87	2.1	1.4

Hypothesis:

Null: No significant difference in wait time

$$H_0: \mu_2 - \mu_1 = 0 \rightarrow \mu_2 = \mu_1$$

Alternate: Significant difference in wait time

$$H_1: \mu_2 - \mu_1 \neq 0 \rightarrow \mu_2 \neq \mu_1$$

Test Statistic:

$$z = \frac{\bar{X}_2 - \bar{X}_1}{\sqrt{\frac{\sigma_2^2}{n_2} + \frac{\sigma_1^2}{n_1}}} = \frac{2.1 - 7.1}{\sqrt{\frac{1.4}{87} + \frac{6.8}{39}}} = \frac{-5.0}{\sqrt{0.016 + 0.17}} = \frac{-5.0}{\sqrt{0.186}} = \frac{-5.0}{0.43} = -11.6$$

Decision Rule:

Confidence Level	Lower Critical Value	Upper Critical Value
95%	-1.96	1.96

Reject null hypothesis if $z \leq$ lower critical value or $z \geq$ upper critical value.

$$z = -11.6 \leq \text{lower critical value}$$

REJECT null hypothesis. Therefore, there is a significant difference in vehicle wait time.

The two-tailed P value is less than 0.0001 for $z = -11.6$. By conventional criteria, this difference is considered to be extremely statistically significant.

Appendix D: Completed Mail-In Surveys

Over the past 7 months you may have noticed additional signs at the intersection of West Tischer Road and Eagle Lake Road. A dynamic intersection warning system was installed by the University of Minnesota-Duluth (UMD). The warning system was designed to provide additional information to assist drivers. To measure the effectiveness of the warning system, please take the time to answer these short survey questions and mail the pre-stamped postcard back to UMD. Thank you for your time.

Questions? Contact Ryan Weidemann at 218-393-3070.

1. On average, how many times a day do you travel through the intersection of West Tischer Road and Eagle Lake Road?

- 0 1 2 3 or more

2. How much do you agree with the following statements:

	Strongly Agree	Agree	Disagree	Strongly Disagree
The warning system is easy to understand	<input type="checkbox"/>	<input type="checkbox"/>	<input checked="" type="checkbox"/>	<input type="checkbox"/>
The warning system improved the safety of the intersection	<input checked="" type="checkbox"/>	<input type="checkbox"/>	<input type="checkbox"/>	<input type="checkbox"/>
The warning system could be used at other intersections	<input checked="" type="checkbox"/>	<input type="checkbox"/>	<input type="checkbox"/>	<input type="checkbox"/>

3. How would you rate the overall effectiveness of the warning system?

- Excellent Good Fair Poor

4. Additional comments.

It took a while to understand it, but it made us aware. Good idea.

Over the past 7 months you may have noticed additional signs at the intersection of West Tischer Road and Eagle Lake Road. A dynamic intersection warning system was installed by the University of Minnesota-Duluth (UMD). The warning system was designed to provide additional information to assist drivers. To measure the effectiveness of the warning system, please take the time to answer these short survey questions and mail the pre-stamped postcard back to UMD. Thank you for your time.

Questions? Contact Ryan Weidemann at 218-393-3070.

1. On average, how many times a day do you travel through the intersection of West Tischer Road and Eagle Lake Road?

- 0 1 2 3 or more

2. How much do you agree with the following statements:

	Strongly Agree	Agree	Disagree	Strongly Disagree
The warning system is easy to understand	<input type="checkbox"/>	<input checked="" type="checkbox"/>	<input type="checkbox"/>	<input type="checkbox"/>
The warning system improved the safety of the intersection	<input checked="" type="checkbox"/>	<input type="checkbox"/>	<input type="checkbox"/>	<input type="checkbox"/>
The warning system could be used at other intersections	<input checked="" type="checkbox"/>	<input type="checkbox"/>	<input type="checkbox"/>	<input type="checkbox"/>

3. How would you rate the overall effectiveness of the warning system?

- Excellent Good Fair Poor

4. Additional comments.

This system was needed for years - many accidents ago - Thank you!

Over the past 7 months you may have noticed additional signs at the intersection of West Tischer Road and Eagle Lake Road. A dynamic intersection warning system was installed by the University of Minnesota-Duluth (UMD). The warning system was designed to provide additional information to assist drivers. To measure the effectiveness of the warning system, please take the time to answer these short survey questions and mail the pre-stamped postcard back to UMD. Thank you for your time.

Questions? Contact Ryan Weidemann at 218-393-3070.

1. On average, how many times a day do you travel through the intersection of West Tischer Road and Eagle Lake Road?

- 0 1 2 3 or more

2. How much do you agree with the following statements:

	Strongly Agree	Agree	Disagree	Strongly Disagree
The warning system is easy to understand	<input type="checkbox"/>	<input checked="" type="checkbox"/>	<input type="checkbox"/>	<input type="checkbox"/>
The warning system improved the safety of the intersection	<input type="checkbox"/>	<input type="checkbox"/>	<input type="checkbox"/>	<input checked="" type="checkbox"/>
The warning system could be used at other intersections	<input type="checkbox"/>	<input type="checkbox"/>	<input type="checkbox"/>	<input checked="" type="checkbox"/>

3. How would you rate the overall effectiveness of the warning system?

- Excellent Good Fair Poor

4. Additional comments.

This device does not promote safety

Over the past 7 months you may have noticed additional signs at the intersection of West Tischer Road and Eagle Lake Road. A dynamic intersection warning system was installed by the University of Minnesota-Duluth (UMD). The warning system was designed to provide additional information to assist drivers. To measure the effectiveness of the warning system, please take the time to answer these short survey questions and mail the pre-stamped postcard back to UMD. Thank you for your time.

Questions? Contact Ryan Weidemann at 218-393-3070.

Thank you

1. On average, how many times a day do you travel through the intersection of West Tischer Road and Eagle Lake Road?

- 0 1 2 3 or more

2. How much do you agree with the following statements:

	Strongly Agree	Agree	Disagree	Strongly Disagree
The warning system is easy to understand	<input checked="" type="checkbox"/>	<input type="checkbox"/>	<input type="checkbox"/>	<input type="checkbox"/>
The warning system improved the safety of the intersection	<input checked="" type="checkbox"/>	<input type="checkbox"/>	<input type="checkbox"/>	<input type="checkbox"/>
The warning system could be used at other intersections	<input checked="" type="checkbox"/>	<input type="checkbox"/>	<input type="checkbox"/>	<input type="checkbox"/>

3. How would you rate the overall effectiveness of the warning system?

- Excellent Good Fair Poor

4. Additional comments.

It's short time safety devices were installed. It is an intersection that causes anxiety when crossing.

Appendix E: Letter from Resident

Ryan Weidemann

Dear Mr. Weidemann,

My wife or I probably go through the intersection of West Tischer Rd and Eagle Lake Rd about 20 times per week. But since we have lived about three quarters of a mile from the intersection for over twenty five years we are well aware of the limited sight distances at the intersection. We are also aware of the mentally challenged young man who can often be found riding his bicycle near the intersection, and also the large family with many young children dwelling in the house just east of the intersection. I am quite sure that most other residents of our neighborhood are aware of the dangers near the intersection and have long taken special caution while driving through that intersection. I simply wanted to point out that data you obtain from your questionnaires sent to people in the neighborhood should be weighed accordingly.

I also do not understand the questions asking if safety and overall effectiveness have been improved. We do not have access to any data about accidents or incidents before and after the installation of the warning signs. If your intent was to ask if we *feel* safer, the answer is no.

Quite frankly, I am more concerned that some people traveling north / south through the intersection are going to start relying too much on the warning lights signaling approaching traffic, and, if they don't see the warning lights, will execute a "rolling stop" and barge out into the intersection and run over a bicycle or motorcycle or one of the total idiots that sometimes are driving ninety mph. Also, what liabilities does the county incur if the warning system mechanically or electronically fails and an accident occurs? Another question I have is whether the traffic sensor picks up a vehicle that may have gone into the other lane for some reason...to avoid an animal, inattentive driving, drunken driving, etc. Perhaps all my concerns and questions can be positively answered, and all that is needed is more publicity about the system.

The one mile stretch of West Tischer road from the Eagle Lake road to the Jean Duluth road has a 55mph speed limit. The entire rest of the West Tischer road is 30mph, 40mph, or 45mph. Yet the 55mph stretch has two of the worst limited sight distance areas in the entire county, plus a major state snowmobile trail crossing. What's up with that? Every time somebody leaves my driveway they risk their lives because there is only about 150 feet of sight distance in both directions and vehicles are traveling at least 55mph, and very often much faster.

The Martin Road is supposed to be the main east-west artery in the area. As long as the speed limit is 55mph along this stretch of the West Tischer road drivers will view the road as some kind of short cut and subsequently ignore the lower speed limits on the rest of road too. It's just human nature.

I personally think that a lower speed limit and increased law enforcement patrols and ticketing would increase safety far more than the warning system.

I am pleased that UMD is studying traffic safety and experimenting with systems such as this one. I wish you good luck and success with the research. I also hope that your research leads to reducing the speed limit on the West Tischer Road.

Regards,

Gary and Kathy Thompson

Appendix F: Mail-In Survey Comments

Positive

- Excellent pre-warning sign. (1)
- One of the most effective traffic tools I have seen. *Will save a life!* (1)
- We feel safer knowing a car is coming. High tech. (2)
- The warning system is effective but I've seen vehicles run the stop sign because the lights are not flashing. (3+)
- The sign has improved our awareness of the intersection and approaching vehicles. However, recently a friend was hit by a car at that intersection while on motorcycle – so still dangerous. (1)
- It's about time safety devices were installed. It is an intersection that causes anxiety when crossing. (3+)
- This system was needed for years – many accidents ago. Thank you! (2)
- It took awhile to understand it, but it made us aware. Good idea. (3+)
- Thank you! (1)
- It is a very good idea. (2)
- Thank you for putting one there – it's very helpful! (3+)
- It has slowed down the speed of people traveling on West Tischer Road. (3+)
- Surprised to see it. But, I welcome the safety improvement. Thanks Ryan. Justin N. Pederson.

Negative

- The system is not totally consistent. It also teaches new drivers to rely on system not sight. (3+)
- Persons get conflicting information. 1. is it working? 2. can I go as a result? I have been cut off by cross traffic since the installation motorcycle/car. (3+)
- This device does not promote safety. (3+)
- Sometimes they are not working. (2)
- It doesn't always work and now people depend on it. They barely stop if not flashing. 1 accident since installed. 4 way stop would be safer. (3+)
- I'm not sure it works all the time. I try to look and several times I can not see any flashing lights. (1)
- Better if drivers understood it better. Visitors have asked how it works, so it takes getting used too. (3+)
- Stop signs would be much more effective. These signs do not improve safety – it makes it more unsafe. (3+)
- Did not work once when ice was on it. (?)

Suggestive

- Removing the speed limit increase sign (when approaching from the east) would also help. It tells drivers they can speed up past hill. (3+)
- We do not have access to data, so therefore do not know if safety or effectiveness is improved. Lower speed limit to 40 mph and increase law enforcement. (2)
- Less money and maintenance to put in 2 poles with stop signs. Duh! (0)

- It flashes for oncoming traffic from one direction, the sign should say that, but instead says just oncoming traffic. An accident occurred there 2 weeks ago,? if sign was working then. (3+)

Irrelevant

- Presume they help, but never seen them activated. (0)
- Very good warning system. (0)
- Never saw system. (0)
- I wish I could be more help. (0)
- I've only gone that way a few times and have not seen it work. (0)

Appendix G: On-Site Survey Comments

Positive

- A good warning system if it is reliable, a bad warning system if it doesn't work all the time.
- A driver's brother who is a policeman from Iowa saw the warning system and thought it was a great idea. He said he had not seen anything like it.

Negative

- A driver in a dump truck who did not take the survey said the intersection was bad.
- Another driver mentioned the problem of the hill on Eagle Lake Road. She said that people are starting to rely only on the lights and sometimes they do not work
- When the signs are working the system is neat. The driver questions the intelligence of other drivers to understand how the system works. He told his son who is a new driver to ignore the flashing lights and just use the stop signs to look for vehicles. He is worried his son will eventually rely solely on the blinking signs and not his vision.

Suggestive

- Larger and brighter lights like the yellow ball flashers on Highway 53.
- During certain times of the day the sun shines on the north side sign "Vehicle Approaching When Flashing" sign and the blinking LEDs are hard to see.
- Worried about young drivers trusting the sign too much. Should put in a 4-way stop like the one on West Tischer Road and Arnold Road.
- The speed limit on West Tischer Road is too fast. In the winter if your vehicle is not 4-wheel drive, residents must get a "running start" traveling north on Eagle Lake Road and crossing the intersection in order to get up the hill.
- Would prefer a 4-way stop instead of the warning system. Also mentioned the trouble of getting up the hill on Eagle Lake Road in the winter.
- A driver would like a sign put up with a phone number they can call if they see the signs not working.