

Application of NMR in the Characterization of Existing and Development of New Methods for  
Pancreas Preservation

A DISSERTATION  
SUBMITTED TO THE FACULTY OF THE GRADUATE SCHOOL  
OF THE UNIVERSITY OF MINNESOTA  
BY

William Earl Scott III

IN PARTIAL FULFILLMENT OF THE REQUIREMENTS  
FOR THE DEGREE OF  
DOCTOR OF PHILOSOPHY

Advisor: Klearchos K Papas Ph.D.

October 2012



## **Acknowledgements:**

I would like to thank the myriad of people who have helped contribute to the execution of the work presented in this dissertation.

### **Klearchos Papas:**

I would like to thank Klearchos for the opportunity to do this work in his lab; for challenging me with so much responsibility; for all of the opportunities to present my work and build a presence and reputation in the field as an actual face; and for always challenging me to do more.

### **Efstathios Avgoustiniatos:**

I would like to thank Stathis for all of his discussion and input (sometimes even when you didn't really have time). I have found that your strong moral compass; attention to detail to a fault (sometimes); and ability to help mediate disputes and give me insight into challenges has deeply impacted my development as a scientist and (hopefully) rubbed off on me to pass on to future generations.

### **Bruce Hammer:**

I would like to thank Bruce for helping baptize me in the wonderful wacky world of NMR. Thanks for integrating me into your lab and for always having an open door and phone-line when I had (mostly odd hour) experiments going.

## **Acknowledgements:**

### **Ron Siegel:**

I would like to Thank Dr. Siegel for helping to identify areas of improvement for me professionally and for the opportunities to work on them with you and your group.

### **David Sutherland:**

I would like to thank you for your insights and discussion into my work. The levels of accomplishments, total recall of the literature, and deep insights into how to treat the pancreas have been truly invaluable to the execution of this work.

### **Joana Ferrer-Fabregas & Shuichiro Matsumoto:**

I would like to thank Joana and Ichiro for baptizing me into the world of surgery and helping to make this work possible. I entered the University of Minnesota as a simple bio-medical engineer and leave with the insights and ability to directly communicate with transplant surgeons thanks to your generous donation of time, accepting of me in discussions as an equal and patience with my learning curve. I would not be what I am today with you.

### **Brad Weegman, Sam Stein, & Tom Suszynski:**

I would like to thank the other grad students in our lab for the endless hours working as a team, discussion, and opportunities to provide some mentorship....

## Acknowledgements:

A list of all contributors is given below:

### Thesis Committee:

**Advisor:** Klearchos Papas  
Stathis Avgoustiniatos  
Bruce Hammer  
Ron Siegel

### Papas Lab:

Nichole Atchison  
Ryan Chaimberlain  
Christopher Chapman  
Eric Falde  
Joana Ferrer-Fabrega  
Varun Garg  
Becca Hooper  
Lou Kidder  
Jenna Kitzmann  
Varia Kircner  
Bob Konz  
Conner Lyons  
Kristen Maynard  
Kate Mueller  
Mike Rizzari  
Philip Rozak  
Chun Shan  
Sam Stein  
Tom Suszynski  
Garrett Swindlehurst  
Jikku Thomas  
C. Julia Vance  
Min Wang  
Brad Weegman  
Gina Wildey

### Other Key Contributors

Tor Aasheim  
Muhammad Abdulla  
Janine Abouaish  
Kurt Albeck  
Taka Anazawa  
Jeff Ansite  
Balamurugan Appakalai  
Daniel Brandhorst  
Heide Brandhorst  
Diana Freeman  
Andrew Friberg  
Tom Gilmore  
Melanie Graham  
Jian Qiang Hao  
Bernhard Hering  
Michael Hetzel  
Minna Honkanen-Scott  
Britta Kurmis  
Suzie LaFreniere  
Gopal Loganathan  
Nicole Mackenzie  
Shuichiro Matsumoto  
Mike Murtaugh  
Luke Mutch  
Tim O'Brien  
Pratima Pakala  
Jamen Parkey  
Brian Perrault  
Sajjad Soltani  
Brett Sorge  
Simon Stone  
David Sutherland  
Tomo Tanaka  
Mike Taylor  
Linda Tempelman  
Mukesh Tiwari  
Josh Wilhelm  
Phil Williams  
Ivy Yu  
Takeshi Yuasa

**Dedication:**

I would like to dedicate this dissertation to my parents who inspired and encouraged me to pursue my interests in science from a young age and have provided mental and sometimes financial support over the course of my journey to obtain this degree.

I would also like to thank my amazing wife Minna who has not only provided me with moral support but also assisted me professionally from time to time. I am not sure I would have been able to complete this undertaking without her help and understanding.

I would also like to thank my friends who have helped me relax and keep a level head over the course of my studies...Mac, Jay, Jon, Brad, Clarence and the guys on the BME softball team I thank you for all you have given to me...as well as the occasional free drink...

Finally I would like to dedicate this to all of the long hours, sleepless nights and hard work I have put in with all of my co-workers...this is truly the backbone to completion of this work and all of the steps forward I have and will take in my career.

Sincerely,

William E Scott III

**Abstract:**

Islet transplantation is an emerging treatment for Type 1 diabetes. Pancreas preservation has been identified as an area for improvement since many pancreata are exposed to >6-8 hours of cold ischemia reducing viable islet yields. Traditionally utilized methods of preservation depend on low temperatures and specialized preservation solutions to maintain viability. Oxygenation during preservation has been identified as a potential means to extend preservation and improve isolation outcomes. The two-layer method (TLM) was developed to oxygenate pancreata during preservation. After initial excitement, since it relies on oxygen delivery by surface diffusion alone, and oxygenation of human sized pancreata in this manner is impossible; its use clinically has faded. Persufflation (PSF), gaseous oxygen perfusion, offers an alternate means of actively delivering oxygen to tissue via the vasculature. Due to the inability of small animal models to properly demonstrate oxygen limitations, and the lack of consistent availability of human pancreata a porcine model was developed.

In order to aid in the development and proper assessment of new techniques, the use of <sup>31</sup>P-NMR spectroscopy to monitor ATP during preservation was investigated. It was able to confirm that while TLM may provide adequate oxygenation for maintenance of ATP levels in smaller pancreata (rat) it indeed is unable to maintain ATP in larger organs such as the pig or human pancreas. In contrast PSF demonstrated the ability to maintain pig or human pancreata for at least 24 hours with only a minimal decay in ATP levels observed. The relevance of these findings was confirmed both histologically as well as by the gold

standard, islet isolation. Paired studies demonstrated the ability of PSF to maintain and possibly improve outcomes while extending preservation times to at least 24 hours. The methods developed in this dissertation can be applied to the development and comparison of other novel methods of preservation in the pancreas and other organs.



# Table of Contents

<b>LIST OF FIGURES .....</b>	<b>IX</b>
<b>LIST OF TABLES .....</b>	<b>XI</b>
<b>LIST OF PUBLISHED MANUSCRIPTS COAUTHORED IN PURSUIT OF THIS DEGREE.....</b>	<b>XII</b>
<b>LIST OF ABSTRACTS PRESENTED IN PURSUIT OF THIS DEGREE.....</b>	<b>XV</b>
<b>CHAPTER 1: INTRODUCTION .....</b>	<b>1</b>
<b>DIABETES .....</b>	<b>1</b>
<b>ISLET TRANSPLANTATION.....</b>	<b>2</b>
<b>PANCREAS PRESERVATION.....</b>	<b>5</b>
<b>Traditional methods of preservation: .....</b>	<b>5</b>
<b>Perfusion:.....</b>	<b>7</b>
<b>Persufflation:.....</b>	<b>10</b>
<b>Cryopreservation:.....</b>	<b>87</b>
<b>NUCLEAR MAGNETIC RESONANCE .....</b>	<b>88</b>
<b>Theory of NMR:.....</b>	<b>88</b>
<b>NMR Spectroscopy:.....</b>	<b>92</b>
<b>REFERENCES .....</b>	<b>94</b>
<b>CHAPTER 2: REAL-TIME NONINVASIVE ASSESSMENT OF MURINE PANCREATIC ATP LEVELS WITH NUCLEAR MAGNETIC RESONANCE SPECTROSCOPY.....</b>	<b>98</b>
<b>CHAPTER 3: VASCULAR AND DUCTAL ANATOMY OF THE PORCINE PANCREAS.....</b>	<b>111</b>
<b>CHAPTER 4: CHARACTERIZATION AND IMPROVEMENT OF METHODS FOR PORCINE PANCREAS PROCUREMENT.....</b>	<b>142</b>
<b>CONSIDERATIONS FOR PERSUFFLATION: .....</b>	<b>142</b>
<b>CONSIDERATIONS FOR ORGAN HEALTH.....</b>	<b>145</b>
<b>Initial temperature study: .....</b>	<b>147</b>
<b>Histology study: .....</b>	<b>149</b>
<b>Second temperature study: .....</b>	<b>151</b>
<b>CONCLUSIONS:.....</b>	<b>156</b>
<b>REFERENCES:.....</b>	<b>157</b>
<b>CHAPTER 5: OXYGEN PERSUFFLATION IMPROVES AND MAINTAINS PORCINE AND HUMAN PANCREATIC ATP ASSESSED BY <sup>31</sup>P-NMR SPECTROSCOPY.....</b>	<b>158</b>
<b>OXYGEN PERSUFFLATION INCREASES PANCREATIC ATP LEVELS AS SHOWN BY NMR .....</b>	<b>158</b>
<b>OXYGEN PERSUFFLATION MAINTAINS PANCREATIC ATP LEVELS AS SHOWN BY NMR .....</b>	<b>174</b>
<b>CHAPTER 6: PERSUFFLATION IMPROVES PANCREAS HISTOLOGY WHEN COMPARED WITH THE TWO-LAYER METHOD (TLM).....</b>	<b>178</b>
<b>CHAPTER 7: PERSUFFLATION IMPROVES PANCREAS PRESERVATION FOR ISLET ISOLATION WHEN COMPARED WITH THE TWO-LAYER METHOD (TLM).....</b>	<b>191</b>
<b>PERSUFFLATION IMPROVES PORCINE PANCREAS PRESERVATION FOR ISLET ISOLATION WHEN COMPARED WITH THE TWO-LAYER METHOD (TLM).....</b>	<b>194</b>
<b>OXYGEN PERSUFFLATION CAN EXTEND HUMAN PANCREAS PRESERVATION TIME FROM 10 TO 24 HOURS WHILE MAINTAINING VIABLE ISLET YIELD AND QUALITY.....</b>	<b>223</b>
<b>CHAPTER 8: PERSUFFLATION: DEVICE CONSIDERATIONS.....</b>	<b>231</b>

<b>CHAPTER 9: OTHER METHODS TO MONITOR ORGAN VIABILITY BY WHOLE ORGAN OXYGEN CONSUMPTION RATE (WO-OCR) .....</b>	<b>237</b>
<b>CHAPTER 10: CONCLUSIONS AND FUTURE DIRECTIONS.....</b>	<b>250</b>
<b>BIBLIOGRAPHY: .....</b>	<b>254</b>
<b>APPENDICES: .....</b>	<b>269</b>
<b>Appendix 1.....</b>	<b>270</b>
<b>Appendix 2.....</b>	<b>272</b>
<b>Appendix 3.....</b>	<b>274</b>
<b>Appendix 5.....</b>	<b>276</b>
<b>Appendix 6.....</b>	<b>278</b>
<b>Appendix 9.....</b>	<b>280</b>

## List of Figures:

1.1.....	4
1.2.....	6
1.3.....	32
1.4.....	61
1.5.....	73
1.6.....	75
1.7.....	91
2.1.....	103
2.2.....	105
2.3.....	106
3.1.....	121
3.2.....	123
3.3.....	125
3.4.....	129
4.1.....	144
4.2.....	146
4.3.....	147
4.4.....	150
4.5.....	152
4.6.....	153
4.7.....	154
4.8.....	155
5.1.....	167
5.2.....	168
5.3.....	169
5.4.....	175
5.5.....	176
6.1.....	184
6.2.....	187
6.3.....	188
7.1.....	218
7.2.....	219
7.3.....	220

7.4.....	221
7.5.....	225
7.6.....	226
7.7.....	227
8.1.....	231
8.2.....	232
8.3.....	234
8.4.....	235
9.1.....	243
9.2.....	245

## List of Tables:

1.1.....	16
1.2.....	28
1.3.....	45
1.4.....	55
1.5.....	60
1.6.....	66
1.7.....	78
3.1.....	131
3.2.....	131
7.1.....	222
7.2.....	230

## **List of Published Manuscripts Coauthored in Pursuit of This Degree:**

1. H Brandhorst, M Iken, **WE Scott III**, KK Papas, B Theisinger, PR Johnson, O Korsgren, D Brandhorst: Quality of isolated pig islets is improved using perfluorohexyloctane for pancreas storage in a split lobe model. *Cell Transplantation*. In press.
2. T Minor, **WE Scott III**, MD Rizzari, TM Suszynski, B Luer, P Efferz, KK Papas, A Paul: Energetic recovery in porcine grafts by minimally invasive liver oxygenation. *Journal of Surgical Research*. In press.
3. ES Avgoustiniatos, **WE Scott III**, TS Suszynski, HJ Schuurman, RA Nelson, PR Rozak, KR Mueller, AN Balamurugan, JD Ansite, DW Fraga, AS Friberg, GM Wildey, T Tanaka, CA Lyons, DER Sutherland, BJ Hering, KK Papas: Supplements in Human Islet Culture: Human Serum Albumin is Inferior to Fetal Bovine Serum. *Cell Transplantation*. In press.
4. BP Weegman, MJ Taylor, SC Baicu, **WE Scott III**, KR Mueller, JP Kitzmann, MD Rizzari, KK Papas: Hypothermic Perfusion Preservation of Pancreas for Islet Grafts: Validation using a Split Lobe Porcine Model. *Cell Transplantation*. [Epub ahead of print]
5. TM Suszynski, MD Rizzari, **WE Scott III**, KK Papas: Persufflation (or Gaseous Oxygen Perfusion) as a Method of Organ Preservation: A Comprehensive Review. *Cryobiology*. 2012; 64(3):125-43.

6. MD Rizzari, TM Suszynski, LS Kidder, SA Stein, TD O'Brien, **WE Scott III**, VA Kirchner, BP Weegman, ES Avgoustiniatos, PW Todd, DJ Kennedy, BE Hammer, DER Sutherland, BJ Hering, KK Papas: Surgical Protocol Involving the Infusion of Paramagnetic Microparticles for Preferential Incorporation within Porcine Islets. *Transplantation Proceedings*. 2010 Dec;42(10):4209-12.
7. **WE Scott III**, TD O'Brien, J Ferrer-Fabrega, ES Avgoustiniatos, BP Weegman, T Anazawa, S Matsumoto, VA Kirchner, MD Rizzari, MP Murtaugh, TM Suszynski, T Aasheim, LS Kidder, BE Hammer, SG Stone, L Tempelman, DER Sutherland, BJ Hering, KK Papas: Persufflation Improves Pancreas Preservation When Compared With the Two-Layer Method (TLM); *Transplantation Proceedings*, 2010 Jul-Aug;42(6):2016-9.
8. **WE Scott III**, BP Weegman, J Ferrer-Fabrega, SA Stein, T Anazawa, VA Kirchner, MD Rizzari, J Stone, S Matsumoto, BE Hammer, AN Balamurugan, LS Kidder, TM Suszynski, ES Avgoustiniatos, SG Stone, L Tempelman, DER Sutherland, BJ Hering, KK Papas: Pancreas Oxygen Persufflation Increases ATP Levels as Shown by NMR; *Transplantation Proceedings*, 2010 Jul-Aug;42(6):2011-5.
9. BP Weegman, VA Kirchner, **WE Scott III**, ES Avgoustiniatos, TM Suszynski, J Ferrer-Fabrega, MD Rizzari, LS Kidder, R Kandaswamy, DER Sutherland, KK Papas: Continuous, Real-time Viability Assessment of Kidneys Based on Oxygen Consumption; *Transplantation Proceedings*, 2010 Jul-Aug;42(6):2020-3.

10. J Ferrer, **WE Scott III**, BP Weegman, TM Suszynski, DER Sutherland, BJ Hering, KK Papas, Pig Pancreas Anatomy: Implications for Pancreas Procurement, Preservation, and Islet Isolation, Transplantation, 2008 Dec; 86(11): 1503-1510.
11. **WE Scott III**, S Matsumoto, T Tanaka, ES Avgoustiniatos, ML Graham, PC Williams, LA Tempelman, DER Sutherland, BJ Hering, BE Hammer and KK Papas, Real-Time Noninvasive Assessment of Pancreatic ATP Levels During Cold Preservation, Transplantation Proceedings, 2008 Mar;40(2):403-6.
12. KK Papas, CK Colton, RA Nelson, PR Rozak, ES Avgoustiniatos, **WE Scott III**, A Pisania, GC Weir, BJ Hering, Human islet oxygen consumption rate and DNA measurements predict diabetes reversal in nude mice, American Journal of Transplantation, 2007 Mar;7(3):707-13.



## **List of Abstracts Presented in Pursuit of This Degree:**

1. **WE Scott III**, MD Rizzari, BP Weegman, TM Suszynski, ES Avgoustiniatos, AN Balamurugan, AC Gruessner, JP Kitzmann, LA Tempelman, SA Stein, BE Hammer, KK Papas, “Oxygen Persufflation Extends Human Pancreas Preservation from 10 to 24 Hr without Loss in Viable Islet Yield and Quality”, To be presented as a poster at: the 2012 American Transplant Congress, Boston, MA, June, 2012.
2. TM Suszynski, **WE Scott III**, BP Weegman, J Li, AS Lam, JD Fonger, JM. Ritter, MD Rizzari, PM Eckman, LA Tempelman, R John, N Chronos, KK Papas, “Persufflation (Gas Perfusion) May Enable Extended Cold Ischemia Time (CIT) during Donor Heart Preservation”, To be presented as a poster at: the 2012 American Transplant Congress, Boston, MA, June, 2012.
3. TM Suszynski, **WE Scott III**, KK Papas, ES Avgoustiniatos, “Anoxia in the Intraportally Transplanted Islet and the Effect of Thrombosis”, To be presented as a poster at: the 2012 American Transplant Congress, Boston, MA, June, 2012.
4. TM Suszynski, **WE Scott III**, BP Weegman, J Li, AS Lam, JD Fonger, JM. Ritter, MD Rizzari, PM Eckman, LA Tempelman, R John, N Chronos, KK Papas, “Persufflation (or gas perfusion) may extend allowable ischemia time during donor heart preservation”, Submitted to: the 32nd Annual Meeting and Scientific Sessions for the International Society for Heart and Lung Transplantation; Prague, Czech Republic, April, 2012.

5. **WE Scott III**, MD Rizzari, BP Weegman, TM Suszynski, ES Avgoustiniatos, AN Balamurugan, AC Gruessner, JP Kitzmann, LA Tempelman, SA Stein, BE Hammer, KK Papas, “Oxygen Persufflation Can Extend Human Pancreas Preservation Time from 10 to 24 hours While Maintaining Viable Islet Yield and Quality”, Presented as an Oral Presentation at: the 2nd Joint AIDPIT and EPITA Winter Symposium & 31st AIDPIT Workshop, Innsbruck, Austria, January 2012.
6. **WE Scott III**, BP Weegman, MD Rizzari, TM Suszynski, EJ Falde, J Ferrer-Fabrega, KK Papas, ES Avgoustiniatos, “Warm ischemia during porcine pancreas procurement is significantly reduced by arterial and ductal flushing”, Presented as a poster at: the Joint Congress of the Cell Transplant Society and the International Xenotransplantation Association; Miami, Florida, October, 2011.
7. TM Suszynski, **WE Scott III**, KK Papas, ES Avgoustiniatos, “Implications of Thrombosis on the Oxygenation of the Intraportally Transplanted Islet”, Presented as a poster at: the Joint Congress of the Cell Transplant Society and the International Xenotransplantation Association; Miami, Florida, October, 2011.
8. ES Avgoustiniatos, PR Rozak, KR Mueller, CA Lyons, **WE Scott III**, EJ Falde, JP Kitzmann, JR Wilson, BJ Hering, KK Papas, “Silicone rubber membrane devices allow islet culture at 20 times the standard surface density with no adverse effects on islet viability, recovery, or potency”, Presented as an oral presentation at: the Joint Congress of the Cell Transplant Society and the International Xenotransplantation Association; Miami, Florida, October, 2011.

9. BP Weegman, ES Avgoustiniatos, MJ Taylor, SC Baicu, JP Kitzmann, KR Mueller, **WE Scott III**, AN Balamurugan, JR Wilson, KK Papas, "Shipping of Juvenile Porcine Islets in Silicon Rubber Membrane (SRM) Vessels", Presented as a poster at: the Joint Congress of the Cell Transplant Society and the International Xenotransplantation Association; Miami, Florida, October, 2011.
10. BP Weegman, MJ Taylor, SC Baicu, **WE Scott III**, KR Mueller, JP Kitzmann, MD Rizzari, KK Papas "Hypothermic perfusion preservation of pancreas for islet grafts: validation using a split lobe porcine model", Presented as a poster at: The 48th Annual Meeting of the Society for Cryobiology; Corvallis, Oregon, July, 2011.
11. BP Weegman, MD Rizzari, , **WE Scott III**, MJ Taylor, SC Baicu, TM Suszynski, ES Avgoustiniatos, MH Loughnane, KK Papas, "Whole Organ Oxygen Consumption Rate (WOOCR): A novel tool for organ assessment prior to transplant" Presented as a poster at the XII TTS Basic Science Symposium. Cape Cod, Massachusetts, June, 2011.
12. MD Rizzari, TM Suszynski, **WE Scott III**, BP Weegman, EB Finger, TD O'Brien, LS Kidder, R Kandaswamy, DE Sutherland, ES Avgoustiniatos, KK Papas, "Preservation via Anterograde Persufflation May Decrease Renal Arterial Damage in a Porcine Kidney Transplant Model", Presented as a poster at the XII TTS Basic Science Symposium. Cape Cod, Massachusetts, June, 2011.
13. **WE Scott III**, MD Rizzari, SA Stein, ES Avgoustiniatos, TM Suszynski, BP Weegman, LA Tempelman, BE Hammer, KK Papas, "Oxygen persufflation of the human pancreas increases ATP levels and improves viable islet yields compared with

- the two-layer method", Presented as an oral presentation at: the 13th World Congress of the International Pancreas and Islet Transplantation Association; Prague, Czech Republic, June, 2011.
14. BP Weegman, MJ Taylor, SC Baicu, **WE Scott III**, KR Mueller, JP Kitzmann, MD Rizzari, KK Papas "Hypothermic perfusion preservation of pancreas for islet grafts: validation using a split lobe porcine model", Presented as an oral presentation at: the 13th World Congress of the International Pancreas and Islet Transplantation Association; Prague, Czech Republic, June, 2011.
15. H Brandhorst, **WE Scott III**, M. Iken, K. Papas, B. Theisinger, O. Korsgren, D. Brandhorst, "Long-term storage of pig pancreata in oxygen-charged perfluorohexyloctane improves islet survival after culture and islet in vitro function compared to perfluorodecalin", Presented as a poster at: the 13th World Congress of the International Pancreas and Islet Transplantation Association; Prague, Czech Republic, June, 2011.
16. H Brandhorst, **WE Scott III**, M Iken, KK Papas, B Theisinger, O Korsgren, D Brandhorst, "Perfluorhexyloctane Improves Post-Culture Survival of Islets Isolated from Long-Term Stored Pig Pancreata", Presented as an oral presentation at: the 1st Joint Meeting of Artificial Insulin Delivery Pancreas and Islet Transplantation and European Pancreas and Islet Transplantation Association Winter Symposium, Innsbruck, Austria, January, 2011.
17. **WE Scott III**, ES Avgoustiniatos, J Ferrer-Fabrega, BP Weegman, VA Kircner, T Anazawa, MD Rizzari, LS Kidder, SA Stein, S Matsumoto, JJ Stone, TM Suszynski,

- TC Aasheim, BE Hammer, AN Balamurugan, TD O'brien, MP Murtaugh, LA Tempelman, DER Sutherland, BJ Hering, and KK Papas, "Oxygen Persufflation Increases Pancreatic ATP Levels and Viable Islet Yield Following 24 Hours Preservation Compared with the Two-Layer Method (TLM)", Presented as a mini-oral presentation at the XXII International Congress of the Transplantation Society; Vancouver, Canada, August, 2010.
18. MD Rizzari, TM Suszynski, LS Kidder, SA Stein, TD O'Brien, **WE Scott III**, VA Kirchner, BP Weegman, ES Avgoustiniatos, PW Todd, DJ Kennedy, BE Hammer, DER Sutherland, BJ Hering, KK Papas, "Development of a Surgical Protocol for Infusion of Paramagnetic Microparticles for Preferential Incorporation Within Porcine Islets". Presented as a poster at the XXIII International Congress of The Transplantation Society. Vancouver, Canada, August, 2010.
19. **WE Scott III**, ES Avgoustiniatos, J Ferrer-Fabrega, T Anazawa, BP Weegman, LS Kidder, S Stein, S Matsumoto, BE Hammer, AN Balamurugan, TD O'brien, M Murtaugh, L Tempelman, DER Sutherland, BJ Hering, and KK Papas, "Pancreas Oxygen Persufflation Increases ATP-Levels and Improves Islet Viability Compared with Two-Layer Method (TLM)", Presented as a poster and awarded as a 'Poster of Distinction' at: the American Society of Transplant Surgeons 10th Annual State of the Art Winter Symposium; FT. Lauderdale, FL, January, 2010
20. **WE Scott III**, J Ferrer-Fabrega, ES Avgoustiniatos, T Anazawa, BP Weegman, S Matsumoto, TD O'brien, M Murtaugh, BE Hammer, I Yu, LS Kidder, KS Maynard, SG Stone, L Tempelman, DER Sutherland, BJ Hering, KK Papas, "Pancreas

- Persufflation for 6HR AND 24HR Improves Viable Islet Yields Compared With the Two-Layer Method”, Presented as an oral presentation at: The Joint Meeting of the International Pancreas and Islet Transplant Association and the International Xenotransplantation Association; Venice, Italy, October 2009.
21. **WE Scott III**, J Ferrer-Fabrega, T Anazawa, BP Weegman, S Stein, S Matsumoto, J Stone, AN Balamurugan, BE Hammer, ES Avgoustiniatos, KS Maynard, SG Stone, L Tempelman, DER Sutherland, BJ Hering, KK Papas, “Pancreas Oxygen Persufflation Increases ATP Levels as Shown by NMR”, Presented as an oral presentation at: The Joint Meeting of the International Pancreas and Islet Transplant Association and the International Xenotransplantation Association; Venice, Italy, October 2009.
22. **WE Scott III**, B Theisinger, BP Weegman, S Stein, H Brandhorst, BE Hammer, ES Avgoustiniatos, KS Maynard, O Korsgren, KK Papas, D Brandhorst, “One-Layer Method With Novel Compound Perfluorohexyloctane Increases Levels of ATP Relative to Perfluorodecalin as Shown by <sup>31</sup>P-NMR Spectroscopy”, Presented as an oral presentation at: The Joint Meeting of the International Pancreas and Islet Transplant Association and the International Xenotransplantation Association; Venice, Italy, October 2009.
23. **WE Scott III**, AN Balamurugan, J Ferrer-Fabrega, T Anazawa, BP Weegman, BE Hammer, S Matsumoto, ES Avgoustiniatos, KS Maynard, DER Sutherland, BJ Hering, KK Papas, “MRI as a Novel Tool to Develop New Methods of Pancreas Distension to Enable Homogeneous Enzyme Distribution for Successful Islet Isolation”, Presented as a poster at: The Joint Meeting of the International Pancreas

- and Islet Transplant Association and the International Xenotransplantation Association; Venice, Italy, October 2009.
24. BP Weegman, **WE Scott III**, T Anazawa, ES Avgoustiniatos, T Yuasa, J Ferrer-Fabrega, MH Loughnane, BE Hammer, BJ Hering, KK Papas, “Whole Kidney Oxygen Consumption Measurement: A Technique for Real-Time Viability Assessment”, Presented as a poster at: The Joint Meeting of the International Pancreas and Islet Transplant Association and the International Xenotransplantation Association; Venice, Italy, October 2009.
25. BP Weegman, J Ferrer-Fabrega, **WE Scott III**, T Anazawa, ES Avgoustiniatos, T Yuasa, MH Loughnane, BE Hammer, BJ Hering, KK Papas, “Whole Pancreas Oxygen Consumption Measurement: A Technique for Real-Time Viability Assessment”, Presented as a poster at: The Joint Meeting of the International Pancreas and Islet Transplant Association and the International Xenotransplantation Association; Venice, Italy, October 2009.
26. J Ferrer, BP Weegman, **WE Scott III**, ES Avgoustiniatos, TM Suszynski, T Anazawa, DER Sutherland, BJ Hering, KK Papas “Towards Reduced Warm Ischemic Damage During Pig Pancreas Procurement”, Presented as an oral presentation at: Joint Meeting of Cell Transplant Society (CTS), and Japan Society for Organ Preservation and Medical Biology (JSOPMB), Okayama, Japan, April, 2009.
27. **WE Scott III**, J Ferrer, R Chamberlain, T Anazawa, BP Weegman, S Matsumoto, BE Hammer, AN Balamurgan, ES Avgoustiniatos, KS Maynard, DER Sutherland, BJ Hering, KK Papas “MRI as a Novel Tool to Optimize Enzyme Distribution and

- Pancreas Distension for Successful Islet Isolation”, Presented as a poster at: 39<sup>th</sup> Annual Meeting of the American Pancreatic Association, Chicago, Illinois, November 2008.
28. J Ferrer, **WE Scott III**, BP Weegman, T Anazawa , TM Suszynski, DER Sutherland, BJ Hering, KK Papas, “Pig Pancreas Anatomy: Implications for Pancreas Procurement, Preservation, and Islet Isolation”, Presented as a poster at: 39<sup>th</sup> Annual Meeting of the American Pancreatic Association, Chicago, Illinois, November 2008.
29. J Ferrer, BP Weegman, **WE Scott III**, ES Avgoustiniatos, TM Suszynski, T Anazawa, DER Sutherland, BJ Hering, KK Papas, “Toward Improved Surgical Techniques for Pig Pancreas Procurement”, Presented as a poster at: 39<sup>th</sup> Annual Meeting of the American Pancreatic Association, Chicago, Illinois, November 2008.
30. **WE Scott III**, S Matsumoto, T Tanaka, ES Avgoustiniatos, ML Graham, PC Williams, LA Tempelman, DER Sutherland, BJ Hering, BE Hammer and KK Papas, “Real-Time Noninvasive Assessment of Pancreatic ATP Levels During Cold Preservation”, Presented as a poster at: Joint Meeting of the International Xenotransplantation Association (IXA), the International Pancreas and Islet Transplant Association (IPITA), and the Cell Transplant Society (CTS), Minneapolis, Minnesota, September 2007.
31. KK Papas, ES Avgoustiniatos, PR Rozak, GM Wildey, RP Konz, **WE Scott III**, TR Gilmore, HJ Zhang, P Bansal-Pakala, C Bonny, MP Murtaugh, BJ Hering, “Seven-day culture enhances potency and reduces immunogenicity of porcine islets”, Presented as an Oral Presentation at: Joint Meeting of the International



- Xenotransplantation Association (IXA), the International Pancreas and Islet Transplant Association (IPITA), and the Cell Transplant Society (CTS), Minneapolis, Minnesota, September 2007.
32. KK Papas, ES Avgoustiniatos, **WE Scott III**, RA Nelson, PR Rozak, GM Wildey, DW Fraga, JD Ansite, T Tanaka, and BJ Hering, “Quality Of Research and Clinical Human Islet Preparations After Culture”, American Transplant Congress, San Francisco, California, May, 2007.
33. KK Papas, **WE Scott III**, ES Avgoustiniatos, RA Nelson, PR Rozak, JD Ansite, DW Fraga, GM Wildey, V Boyd, and BJ Hering. “Effect of Serum on Fractional Viability of Human Islets Cultured for 2 Days”, 8<sup>th</sup> International Congress of the Cell Transplant Society, Milan, Italy, May 2006.



# Chapter 1: Introduction

## Diabetes

Diabetes is a disease in which the body cannot properly regulate blood glucose levels resulting in hyperglycemia, defined by the American Diabetes Association as fasting blood glucose greater than 126 mg/dL. According to the World Health Organization, more than 346 million people worldwide are living with diabetes [1] and this number is expected to double by 2030 [2]. According to the CDC, 25.8 million people live with diabetes in the U.S. alone, comprising 8.3% of the population [3]. In addition to the physical toll the disease inflicts on patients the American Diabetes Association estimates that diabetes sufferers have 2.3 times the annual health care costs compared to normal individuals and this cost was estimated to be greater than \$174 billion in the US alone in 2007 [4]. This cost is rising with a more recent estimate putting the figure at \$376 billion in 2010 and estimating it to rise to \$490 billion by 2030 [5]. Most diabetic patients can be classified into one of the two principal forms of diabetes generally referred to as either Type 1 or Type 2. Type 1 diabetes, also known as insulin dependent diabetes mellitus (IDDM), is a result of the body's inability to produce sufficient levels of insulin to maintain glucose control. Type 2 diabetes is associated with the tissue developing insulin resistance and is generally associated with older individuals.

Specific mechanisms for the development of Type 1 diabetes are not well understood but it is generally accepted that the insulin producing  $\beta$ -cells found in the pancreas are destroyed as a result of an autoimmune reaction where the patient's own immune cells

recognize and kill islets as if they were foreign material. Prior to the discovery and subsequent use of the hormone insulin as a treatment by Frederic Banting and Charles Best, 1921-22, the onset of Type I diabetes was typically followed by death [6]. However following this discovery, patients could survive by monitoring their blood glucose and self-administering insulin to themselves throughout the day. This is still one of the primary courses of treatment for diabetics to this day. Other presently utilized treatments include the use of an insulin pump, whole organ pancreas transplantation and islet transplantation [7].

## **Islet Transplantation**

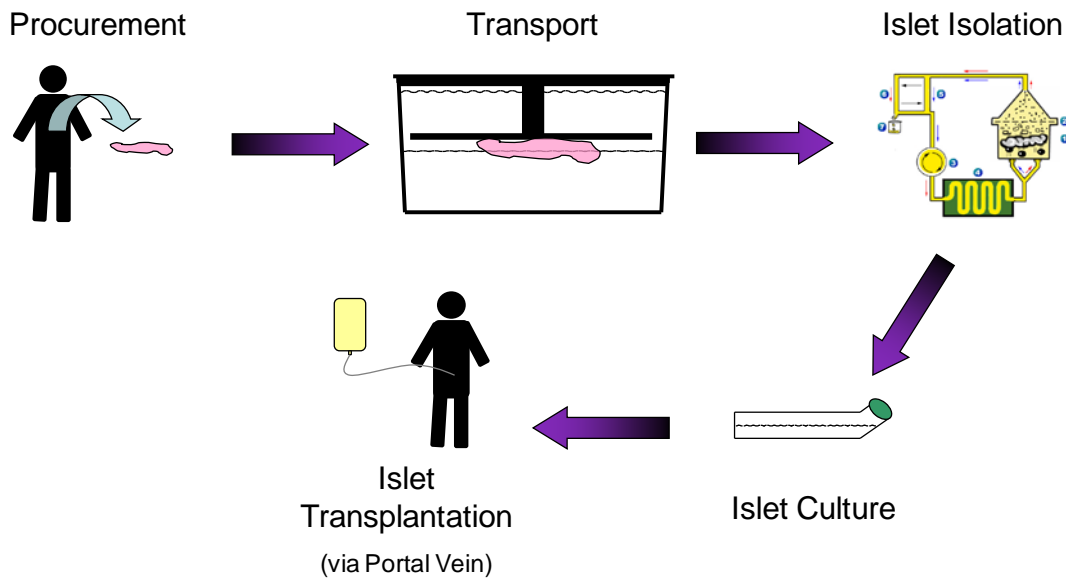
Transplantation of the Islets of Langerhans has been investigated for its potential as a treatment for Type I diabetes Mellitus for over 30 years since the transplantation of islets from rats was shown to reverse chemically induced diabetes [7]. Several years later it was shown that auto-transplantation of islets back to a donor was a feasible treatment to prevent the onset of diabetes in patients with chronic pancreatitis [8]. Successful islet allo-transplantation however remained difficult to achieve until 2000 when the development of the Edmonton Protocol achieved success in 7 consecutive patients transplanted with multiple pancreata [9]. This success was largely attributed to the use of a glucocorticoid free immunosuppression. These results were then repeated at other institutions, including at The University of Minnesota, with variations of the exact immunosuppressive protocol utilized [10].

Islet transplantation offers several advantages to other presently utilized treatments for diabetes. Due to the innate ability of the islets to monitor and regulate glucose levels via insulin production, it allows for the constant tight control of blood glucose levels; something which cannot be achieved by patient self-monitoring. This is especially important in patients who exhibit hypoglycemia unawareness, the lack of physical symptoms indicative of low blood sugar. In addition, when compared to other transplant treatments it reduces the morbidity associated with whole organ transplantation and minimizes the chance of infection since the infusion of islets into the portal vein does not require open surgery.

Even though the use of islet transplantation for consistent diabetes reversal now seems plausible there still remain several hurdles for the wide-spread implementation of this therapy in the clinic. One of these is the present need at most centers for the use of multiple donor organs for a single patient [11]. There is presently a shortage of accessible high quality donor organs which limits the amount of transplants possible. Due to this shortage; maximization of the available organs is of paramount importance. In order to do this it is necessary to protect the islets from damage as much as possible beginning at the time of procurement through eventual engraftment in the transplant recipient. Additionally, transplantation of damaged or dead islets may attract unwanted attention from the host's immune system and eventually lead to graft failure.

The islet transplantation process involves several main stages which each present their own unique challenges to the maintenance of islet viability and these are summarized in

**Figure 1.1.**



**Figure 1.1:**

Flow chart of the major stages involved processing islets for clinical transplantation.

Reducing the severity of some or eventually all of these stresses will aid in the successful engraftment of islets posttransplantation and may reduce the number of islets which need to be transplanted for the eventual goal of prolonged patient glycemic control.

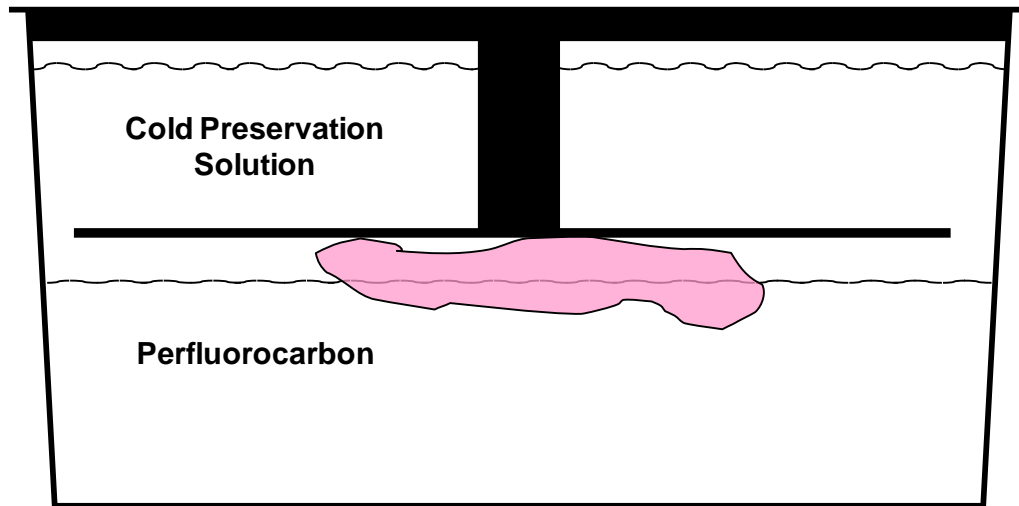
## **Pancreas Preservation**

### **Traditional methods of preservation:**

The period in between when blood flow to the pancreas is stopped and the infusion of digestive enzymes for islet isolation is crucial for maintaining islet health. Exposure to brief periods of warm ischemia or moderate periods of cold ischemia can result in a dramatic decline in pancreatic tissue health and may result in reduced islet yields as well as reduced islet viabilities. It is therefore of great importance to compensate for the loss of blood flow to better maintain tissue during preservation. One of the main strategies employed to compensate for the loss of blood flow is hypothermia. Hypothermia causes a dramatic reduction in metabolic activity and is one of the primary strategies employed to reduce ischemia related damage during organ preservation. However, hypothermia alone is not sufficient to eliminate ischemia related damage and so alternate strategies must be pursued in conjunction with this to improve transplant outcomes.

One of the primary functions of blood is to deliver oxygen throughout the body to tissues. When tissue is exposed to ischemia, oxygen is one of the first nutrients depleted causing a metabolic dysfunction. It is therefore believed that a lack of adequate oxygenation may be responsible for much of the damage observed in organs exposed to extended cold ischemia. It has been posited that improving pancreas preservation via enhanced oxygenation may 1) extend the effective duration of preservation, 2) expand the useable donor pool up to 10-fold, 3) reduce the immunogenicity of transplanted islets, and 4) reduce the number of donors needed per patient [12]. Presently, the two-layer method (TLM), an advanced form of static cold preservation (SCS) involves placing the pancreas at the interface between a cold-storage media and a perfluorochemical. These solutions

are pre-oxygenated prior to procurement and stored at 4-8°C for the duration of organ storage. A conceptual diagram of this can be seen in **Figure 1.2**.



**Figure 1.2:**

Illustration of the two-layer method (TLM) for pancreas preservation.

The two-layer method was first developed for pancreas preservation in the late 80's and early 90's by Saitoh et al at Kobe University in Japan. It was seen as an improvement over the traditional storage in pre-oxygenated University of Wisconsin solution (UW) [13-15]. In the late 90's interest in TLM increased and an optimal storage temperature of 4-8 °C was determined [16]. Soon after this many of the top islet transplantation centers in the world began reporting its benefits to islet yields and transplantation outcomes even suggesting its use may allow for the use of organs from marginal donors [17-21]. These improvements have been attributed to increases in tissue ATP due to enhanced oxygenation [22]. However in recent years the efficacy of TLM has come into question.



Recent publications have suggested that theoretically TLM is not sufficient to oxygenate an entire human pancreas [23]. Another recently investigated method dubbed the ‘one-layer method’ stores the organ on just PFC however even this by diffusion alone should not be adequate for proper oxygenation of the whole organ [24]. On top of that, several recent retrospective studies suggest that TLM shows no beneficial effect on isolation outcome when compared to storage on UW solution alone [25-27].

### **Perfusion:**

Perfusion for the purposes of this discussion refers to the flow of any non-physiological fluid through the vasculature of an organ to aid in its preservation. A specialized method of gaseous perfusion, persufflation, will be discussed separately and so this discussion will focus on the use of liquid perfusion for pancreas preservation. It was found early on that a brief liquid perfusion immediately following the cessation of blood flow can be of significant benefit clearing blood from the tissue and aiding in the cooling process for hypothermic preservation. This is typically done by hanging bags of chilled solutions above the surgical field and allowing this static pressure to drive the solution through the visceral organ pooling in the body cavity. In some countries, notably Japan, the donor pool is limited to non-heart beating cases which expose organs to brief periods of warm ischemia. The use of mechanical pumps has been investigated to aid in the washout and cooling of these organs, but has not found widespread acceptance and use due to endothelial damage and edema found in organs exposed to this process [28].

The remainder of this discussion will focus on the use of machine perfusion for long term pancreas preservation. Indeed, this has proven to be the preservation method of choice in

other organs most notably the kidneys. The use of machine perfusion for pancreas preservation has been shown to be feasible since the early 70's [29]. This work seems to follow up on the early successes of kidney perfusion and from the mid-70's through the early 80's machine perfusion was widely investigated using pumps from many different manufacturers designed for kidney perfusion [30]. This work was primarily targeted to whole organ transplantation primarily using a canine model with only limited investigation into its impact on islet isolation outcomes [31]. Of note was a study by hours Brygner from Sweden which utilized 99% oxygen gas and a membrane oxygenator to try and maintain oxygenation for 24 hours. One side effect experienced was the presence of severe edema (>100%) characterized by the 'spreading of lobules' and a 'jelly-like appearance' [32]. Tissue edema is generally considered to be bad for transplantation and may be a result of the pancreas being a low flow organ [33]. One protocol left a port on the perfusion cassette open during perfusion to shunt some of the flow away from the organ during perfusion which seemed to ameliorate edema for up to 24 hours however edema was present following 48 hours of preservation [33]. It is unclear how much this edema impacts the graft following transplantation. However it has been reported to rapidly dissipate in as little as 15 minutes following transplantation [32]. In general the use of machine perfusion for pancreas preservation was abandoned in the mid-80's primarily due to problems with observed edema, the lack of improvements in transplantation outcomes as well as the additional complications associated with machine perfusion compared with simple static cold preservation.

Following the success of the Edmonton protocol, resurgence in research investigating pancreas machine perfusion for islet transplantation has occurred. Many developments in preservation solutions, perfusion devices as well as the development of the automated process for islet isolation have emerged since machine perfusion was abandoned warranting this. In 2004 Leiser et al demonstrated that machine perfusion may hold some promise for islets exposed to > 8 hours of preservation [34]. This work was followed up by a series of studies performed with the Lifeport Kidney perfusion system by Taylor et al using a 24 hour preservation juvenile pig model [35-37]. These studies again observed severe edema formation. However it was found that the formation of tissue edema may in fact be beneficial to islet isolation resulting in disruption of the extra-cellular matrix surrounding the islets [36, 37]. They observed shorter digestion times, a more homogenous dispersion of the exocrine pancreas as well as improved islet yields (1.6-1.8 x greater than fresh; 2-3 x greater than SCS) which they correlated with the formation of edema in this model [36, 37]. Recently, another group has published a study using the Waters RM3 device which demonstrated improved histology following short term (~5 hour) machine perfusion of juvenile pig pancreata [38]. Of note is the development of a split lobe model for assessing the impact of perfusion which may prove instrumental in comparing emerging methods of pancreas preservation for islet [39].

In addition to possible benefits associated with improved preservation, perfusion offers some unique opportunities to assess organ quality prior to islet isolation or transplantation. Several studies outline methods to assess organ quality during perfusion. In the 90's Kenmochi et al correlated tissue flow rate in pancreata exposed to brief

periods of machine perfusion to transplantation outcomes [40]. Another potential opportunity offered by oxygenated machine perfusion involves the assessment of tissue viability by whole-organ oxygen consumption rate measurement [41] or the non-invasive assessment of ATP content by <sup>31</sup>P-NMR spectroscopy [42-46].

### **Persufflation:**

Persufflation, the perfusion of an organ with gaseous oxygen, is one promising alternative to presently utilized methods of preservation such as the TLM. Please see Appendix 1a for a thorough review of the application of persufflation for organ preservation. This original review article is included with permission of the publishers of the journal 'Cryobiology', Elsevier (Appendix 1): **TM Suszynski, MD Rizzari, WE Scott III, KK Papas: Persufflation (or Gaseous Oxygen Perfusion) as a Method of Organ Preservation: A Comprehensive Review. Cryobiology. 2012;64(3):125-43.**

My contributions to this manuscript include researching the breadth of the manuscripts discussed, performing basic translations, contributing to the discussion presented and contributing to the pancreas PSF section.

**Title:**

Persufflation (or gaseous oxygen perfusion) as a method of organ preservation (Review)<sup>1</sup>

**Authors:**

Thomas M. Suszynski <sup>a</sup>, Michael D. Rizzari <sup>a,b</sup>, William E. Scott III <sup>a,c</sup>, Linda A. Tempelman <sup>d</sup>, Michael J. Taylor <sup>e,f</sup>, Klearchos K. Papas <sup>a,c,\*</sup>

<sup>a</sup>Schulze Diabetes Institute, Department of Surgery, University of Minnesota, Minneapolis, MN, USA

<sup>b</sup>Department of Surgery, University of Texas Southwestern Medical Center, Dallas, TX, USA

<sup>c</sup>Institute for Cellular Transplantation, Department of Surgery, University of Arizona, AZ, USA

<sup>d</sup>Giner, Inc., Newton, MA, USA

<sup>e</sup>Cell and Tissue Systems, N. Charleston, SC, USA

<sup>f</sup>Department of Mechanical Engineering, Carnegie Mellon University, Pittsburgh, PA, USA

---

<sup>1</sup> This work was supported in part by Health Resources and Services Administration Contract 231-00-0115 and by the National Institutes of Health, National Institute of Diabetes and Digestive and Kidney Diseases Grant No.: R44 DK07040. The content is the responsibility of the authors alone and does not necessarily reflect the views or policies of the Department of Health and Human Services, nor does mention of trade names, commercial products, or organizations imply endorsement by the US Government. \* Corresponding author. Address: Institute for Cellular Transplantation, Department of Surgery, University of Arizona, 1656 E. Mabel Street, Room 121, Tucson, AZ 85724, USA. Fax: +1 520 626 7779.

E-mail addresses: [kkpapas@surgery.arizona.edu](mailto:kkpapas@surgery.arizona.edu), [papas006@umn.edu](mailto:papas006@umn.edu) (K.K. Papas).

Improved preservation techniques have the potential to improve transplant outcomes by better maintaining donor organ quality and by making more organs available for allotransplantation. Persufflation, (PSF, gaseous oxygen perfusion) is potentially one such technique that has been studied for over a century in a variety of tissues, but has yet to gain wide acceptance for a number of reasons. A principal barrier is the perception that *ex vivo* PSF will cause *in vivo* embolization post-transplant. This review summarizes the extensive published work on heart, liver, kidney, small intestine and pancreas PSF, discusses the differences between anterograde and retrograde PSF, and between PSF and other conventional methods of organ preservation (static cold storage, hypothermic machine perfusion). Prospective implications of PSF within the broader field of organ transplantation, and in the specific application with pancreatic islet isolation and transplant are also discussed. Finally, key issues that need to be addressed before PSF becomes a more widely utilized preservation strategy are summarized and discussed.

**Keywords:**

Gaseous oxygen perfusion

Persufflation

Organ preservation

**Abbreviations:**

ADP	adenine diphosphate
AMP	adenine monophosphate
A-PSF	anterograde persufflation
ATP	adenosine triphosphate
CPB	cardiopulmonary bypass
DCD	donation after cardiac death
HMP	hypothermic machine perfusion
POD	post-operative day
PSF	persufflation
R-PSF	retrograde PSF
SCS	static cold storage
SOD	superoxide dismutase
TLM	two-layer method
UNOS	United Network for Organ Sharing
UW	University of Wisconsin
WIT	warm ischemia time

## **Introduction:**

The advancement of allotransplantation over the past half century has stimulated the development of techniques for whole organ preservation, especially in the face of common logistical challenges inherent in the delivery of the therapy (such as the need for transportation and coordination of operating times). In addition to preserving the function and viability of cadaveric organs accepted via standard criteria, improved organ preservation has the potential to increase the fraction of marginal organs used for transplant [60,90]. It is generally believed that improved preservation techniques should contribute to improved maintenance of organ quality, minimize ischemia–reperfusion injury and result in more successful transplant outcomes, which has led to substantial research effort to optimize organ preservation protocols. A key area of research interest lies in the optimization of oxygen delivery during hypothermic preservation. It has been shown that conventional static cold storage (SCS) techniques may not provide sufficient oxygen to the core of a larger organ [33,90], and only oxygenate to a maximum depth of a millimeter from the surface [63]. Efforts to improve the oxygen solubility of cold preservation solutions by using perfluorocarbons have proven largely ineffective, because these methods still rely on oxygen delivery by passive diffusion from the surface [2]. Even hypothermic machine perfusion (HMP), which has been designed to deliver cold preservation solution into the organ via the native vasculature, may deliver inadequate oxygen to an organ during preservation, particularly when the perfusate is not saturated with oxygen at a higher than atmospheric pO<sub>2</sub> [41,92,99]. It is in this regard that persufflation (PSF), or gaseous oxygen perfusion, may provide additional advantages as compared to either SCS or HMP (see **Table 1.1** for more detailed comparison of the



advantages and disadvantages between SCS, HMP and PSF). PSF is not a new concept but can be considered an emerging technique for current-day organ preservation and deserves considerable attention for a variety of compelling reasons, including the unique capability to deliver oxygen gas or gas mixture directly into an organ by using the native vasculature. When compared with SCS and HMP, PSF may represent the best opportunity to fully oxygenate an entire, human-sized organ. This review details the historical development of PSF with heart, kidney, liver, small intestine and pancreas and discusses the differences between the 2 main approaches for PSF (anterograde versus retrograde). We also discuss the future research landscape for PSF in relation to established methods of preservation and describe some of the important issues that need to be addressed before the technique becomes more widely accepted.

Preservation technique	Advantages	Disadvantages
Static cold storage (SCS)	Easiest and cheapest to implement Simplest logistical considerations	Significant nutrient delivery and oxygen diffusion limitations Extends core organ warm ischemia time and characterized by slow, inhomogeneous cooling Cannot extend allowable cold ischemia time or resuscitate ischemically-damaged organs May increase risk of damage to vascular structures
Hypothermic machine perfusion (HMP)	Can efficiently deliver nutrients and oxygen into the core of the organ under appropriate conditions Can continuously clear waste products during preservation period Can extend preservation period up to 48-72 h in kidneys and may in other organs May be able to monitor viability more easily	Can cause edema within organ ('perfusion nephropathy') Common perfusates have limited oxygen solubility, especially as compared with blood Perfusion pressures may damage endothelium (possibly affecting vascular function and/or inducing thrombosis) Useable substrates may be washed out Risk of transmitting reactive antibodies or pathogens may exist (if cryoprecipitated plasma is used) More challenging logistical considerations Fairly complicated and expensive technique to implement
Perfusion (PSF)	Can deliver more oxygen per gram tissue than SCS or HMP Gaseous perfusate has lower viscosity, may reach more regions of preserved organs and does not cause edema Can extend preservation time and may be able to resuscitate marginal organs May be able to monitor viability more easily May be simpler to implement than HMP	May increase risk of damage to vascular structures Depending on gaseous oxygen concentration, may induce hyperoxic damage in tissue Risk of damaging tissue by desiccation if gas is not properly humidified during long-term preservation PSF resembles iatrogenic gas embolization and challenges clinical dogma Cannot deliver nutrients like liquid perfusion and may be less efficient at removing waste products

**Table 1.1:**

Potential advantages and disadvantages of hypothermic organ preservation techniques.

## **Early history with persufflation**

PSF was first discovered in 1902 by Rudolf Magnus, when he made an unexpected observation while perfusing an isolated cat heart with defibrinated blood [42]. The reservoir storing liquid perfusate emptied inadvertently and was not re-filled immediately. Since compressed oxygen gas was used to pressurize the reservoir, the gas was pulled into the perfusion circuit and into the heart. Magnus observed that the heart continued to contract rhythmically for 9 minutes during PSF. This initial observation prompted the initiation of a series of more extensive studies designed to elucidate the utility of PSF in preserving cardiac function. Magnus illustrated that it was possible to maintain a beating heart in bradycardia during 69 minutes of PSF and that reperfusion of blood through the coronaries restored a normal heart rate (80 bpm). Interestingly, Magnus persufflated the cat heart with gaseous hydrogen and showed that it still beat at 20 minutes of treatment. Furthermore, he tried coronary persufflation with gaseous carbon dioxide and was able to demonstrate, unlike either oxygen or hydrogen gas, that the heart stops after just minutes. Even though Magnus' findings were intriguing at the time, it was not until the mid-1950s that the significance of his studies was appreciated. With the advent of clinical transplant on the near horizon [24,45], a group at McGill University in Montreal discovered in 1954 that PSF could preserve spinal reflexes in frogs and active cardiac and skeletal muscle contractions in rabbits [5,6]. Their first paper highlighted the benefits of PSF versus liquid perfusion in a frog spinal reflex model [5]. The authors showed that peripheral nerve reflexes and muscle contractions were preserved for up to 6–8 hours when the gaseous oxygen was delivered into the systemic circulation. This paper described the significant benefit of PSF over liquid perfusion, citing the lack of

edema formation and improved oxygenation. The authors even replaced oxygen gas with nitrogen gas to illustrate how anoxia eliminated these reflex activities. In a related, follow-up study the same group showed that a rabbit heart and skeletal muscle (tibialis anterior muscle) could be preserved with minimal depreciation of function during about 3 hours of PSF [6].

These early reports establishing the potential virtues of PSF for improved organ preservation set the scene for exploration in a variety of tissues and organs.

## **Whole organ persufflation**

### **Heart**

Although the earliest studies of PSF were focused on the heart, research in heart PSF had subsided for about 3 decades (1960s–1990s) in favor of research in liver and kidney PSF. More recently, cardiac PSF has been rekindled and several studies have been published in which PSF was used prior to transplant, including the use of PSF to preserve hearts having suffered short periods of warm ischemia. Collectively, these studies have at least established that cardiac PSF is technically possible and that it can preserve heart tissue.

The advent of cardiopulmonary bypass (CPB) in the mid-1950s provided impetus for exploring the use of PSF with the heart. In 1959, Sabiston et al. at Johns Hopkins explored the use of PSF in conjunction with CPB [76]. In the first set of experiments,

hearts from medium-sized dogs were cannulated at the coronary ostia, flushed with pre-oxygenated normal saline, and then persufflated with humidified gaseous carbogen (a mixture of 95% O<sub>2</sub> and 5% CO<sub>2</sub>). This approach, generally termed anterograde PSF (A-PSF), contrasts with retrograde PSF (R-PSF) which would be tried in the heart [8,87] and subsequently in the kidney [28,32]. Hearts maintained at 37 °C continued to beat for an average duration of 5.1 hours (2.5–8 hours, range). Cardiac contractility remained strong for the first 2–3 hours and then gradually weakened. In some cases, the electrical activity of the heart continued for periods up to 4 hours following cessation of a visible heartbeat. The second set of experiments examined in situ A-PSF of the heart. Once the heart had been isolated from the systemic circulation, A-PSF was performed for 25–30 minutes. A normal hemodynamic response was restored in 9 of 12 animals and some animals maintained a heartbeat for 48 hours following the reestablishment of native coronary circulation. This study established the use of PSF in cardiac surgery by showing that oxygen gas can be used by the heart and that coronary blood flow may be reestablished after PSF. In 1960, a follow-up study introduced the concept of R-PSF [87]. At the time, retrograde perfusion of oxygenated blood via the coronary sinus was used to maintain a heartbeat and protect the heart from anoxia for short periods of time during open aortic valve procedures [22,43]. Talbert et al. used this knowledge, along with their previous work on A-PSF, to investigate whether R-PSF could be performed successfully in the heart. In their experiments, the coronary sinus was cannulated in 7 canine hearts, flushed with normal saline and started on R-PSF. These organs maintained a beat for an average duration of 3.5 hours (2–4 hours, range). In 3 separate hearts, the anterior cardiac veins were additionally cannulated and persufflated. These organs maintained a visible beat for

an average duration of 5.5 hours and up to 7 hours. They noted that cardiac activity remained strong over the first 2 hours of experimental conditions and then gradually became weaker until ventricular fibrillation or complete asystole had occurred. Talbert compared the R-PSF with A-PSF and determined that the heartbeat was visibly weaker and sustained for a shorter period of time using the retrograde approach. Nevertheless, they concluded that oxygen gas can be delivered retrogradely and that the method exhibits some efficacy.

In 1966, the Talbert et al. concept of R-PSF was applied during CPB by Camishion et al. [8]. They noted that continuous blood perfusion during open aortic valve procedures was cumbersome due to the obstruction of the surgical field caused by cannulation of the coronary vessels from within the aorta. Consequently, they tried to determine whether animals could survive CPB by using R-PSF of the coronary sinus as the main preservation technique. This was investigated by repeating previous work by Talbert et al. on in situ R-PSF using a similar canine model [87]. They reported that each of 10 canine hearts maintained a sinus rhythm for at least 31 minutes while being retrogradely persufflated. Following the loss of a sinus rhythm, 8 animals maintained a nodal or ventricular rhythm for up to 7 hours and 2 animals developed and sustained ventricular fibrillation for up to 6 hours. When hearts were persufflated with nitrogen gas, sinus rhythm was maintained for 5 minutes or less and a visible beat was lost in all 10 animals within an average duration of 11 minutes and no longer than 25 minutes. When persufflation was switched to oxygen gas, a 30-fold increase in the tissue oxygen partial pressure of the hearts was observed almost immediately. In 2 animals, asystole was

converted to a persistent ventricular rhythm. In a second experimental study, the coronary sinus in 20 porcine and 10 canine hearts were cannulated and animals were placed on CPB using R-PSF for 1 hour. During CPB, 25 of 30 animals maintained sinus rhythm for the entire hour. Of the remaining 5 animals, all developed ventricular fibrillation after an average of 30 minutes and 1 spontaneously reverted to a nodal rhythm after 20 minutes of sustained ventricular fibrillation. Following removal of CPB, 22 of 30 animals remained in sinus rhythm. Four animals with ventricular fibrillation were converted electrically to sinus rhythm, 3 animals developed fibrillation after reperfusion, all of which could be converted electrically to sinus rhythm. The remaining animal exhibiting nodal rhythm converted to normal sinus rhythm spontaneously following cessation of CPB. After re-establishment of native coronary blood flow, mean aortic blood pressure was maintained between 60–120 mm Hg and central venous pressures remained 4.4–14.7 mm Hg in all animals. Of the 30 experimental animals in the second group, only 1 exhibited signs of heart failure postoperatively. This animal developed severe pulmonary edema following transfusion of 2500 mL of blood for ongoing hemorrhage. From the vantage point of a contemporary understanding of shock and transfusion medicine, it is conceivable that this animal may have developed a variant of acute respiratory distress syndrome or transfusion-related acute lung injury, which may have been misinterpreted as pulmonary edema from congestive heart failure – though the true pathology will never be known. Nevertheless, these studies illustrated that a heart could be preserved by PSF during CPB and that these organs recovered their function following reperfusion. No evidence of air embolization in the brain or viscera of any experimental animal. The authors commented on the fundamental difference between gas embolization and PSF; gas emboli are small

bubbles that may occlude smaller vessels, whereas PSF is characterized by the free flow of a gas within the vascular system. This distinction is still not fully appreciated by the clinical community and services to highlight that this will need to continue to be proven experimentally. Camishion et al. also raised the possibility of using this preservation technique for the maintenance of donor hearts in cardiac transplant, even before the first successful heart transplant was performed in South Africa a few years later [3].

Also in 1966, Gabel et al. examined the physiology of the persufflated heart by using juvenile feline hearts that were anterogradely persufflated with gaseous carbogen mixture (95% O<sub>2</sub>, 5% CO<sub>2</sub>) via cannulae secured in the proximal aorta and compared with controls perfused with substrate-free Krebs solution [21]. They found that the heart rate in persufflated hearts declined rapidly over the first hour and then declined more slowly over the next 9 hours, whereas the heart rate in the liquid-perfused heart exhibited a steady decline over the entire experimental period. Contractility measurements under A-PSF showed an initial rise in contractile force during the first 20 minutes and subsequent fall after 4 hours. The persufflated hearts reached 50% of the initial contractile force after 7 hours, whereas liquid-perfused hearts declined to 50% of initial contractile force in only 80 minutes. Metabolic studies revealed that glycogen, carbohydrate, lactate, and pyruvate levels decreased rapidly in the persufflated heart, but when these hearts were treated with pharmacologic agents they responded as expected. In addition, they found that rhythm changes in the A-PSF model reproducibly occurred above a certain threshold PSF pressure. Gabel et al. concluded that persufflated hearts exhibited stronger contractile forces, performed more work and were slower to fail than the hearts perfused with liquid.



They theorized that oxygen gas allowed an increase in cardiac work, even though oxygen supply is not traditionally considered a major determinant of work capacity. It may be that cardiac oxygen extraction is altered when oxygen is delivered by PSF or that simply more oxygen is delivered using PSF. Another hypothesis emerging from these findings was that, in the case of PSF, active metabolites equilibrate solely between the extracellular fluid and the intracellular space, as opposed to being flushed away by a liquid perfusate.

Lochner et al. subsequently studied the metabolism and function of anterogradely persufflated guinea pig and rat hearts [40]. Hearts were persufflated with carbogen gas mixture (95% O<sub>2</sub>, 5% CO<sub>2</sub>) at 37 °C for 1 hour. With persufflated hearts, the peak systolic pressures and the first derivative of the left ventricular systolic pressure decreased, while exhibiting very little change in the heart rate. This seemed to indicate that the persufflated heart could continue to generate hemodynamic work. In a few of the hearts, A-PSF time was extended to 2 hours, resulting in no additional decreases in heart rate, left ventricular systolic pressure and its first temporal derivative, or isovolumetric work. Isovolumetric work and the first derivative of left ventricular systolic pressure following PSF were calculated to be 16.4–18.4% of values characteristic for liquidperfused hearts, respectively. Measurements of tissue creatine phosphate and ATP were similar between the PSF and liquid perfusion groups. This led the authors to suggest that the decrease in cardiac work was likely not due to a lack of available cellular energy. They also discovered that work capacity could be enhanced by increasing the PSF pressure or the diastolic filling pressure.

Following these early studies, there was a gap of several decades during which no work was published on the gaseous perfusion of hearts. It was not until the late 1990s that interest in cardiac PSF rekindled, largely as a result of the successful application of PSF in other organs, in particular the kidney and liver. What had been previously referred to as ‘gaseous oxygen perfusion’ was eventually termed ‘persufflation’ by Denecke [10]. After pursuing extensive work with kidneys and livers, Fischer’s group in Cologne explored cold preservation via cardiac PSF in 1998 [35]. Porcine hearts were flushed and stored at 0–1 °C using 3 different methods: (1) SCS using modified Euro-flush solution with glutathione (based on Euro-Collins solution); (2) SCS with University of Wisconsin (UW) solution; and (3) A-PSF via the ascending aorta in combination with SCS using Histidine-Tryptophan-Ketoglutarate solution modified by adding hyaluronidase. The overall mean preservation time was 14.5 hours. Hearts were orthotopically transplanted into recipient pigs of comparable body weight using standard CPB, reperfused on CPB using whole blood for an average of 154 minutes before being weaned off CPB to allow the hearts to take over normal circulation. Following transplantation, hemodynamic parameters were measured to estimate cardiac function and serum creatine kinase values were obtained as an indicator of myocardial damage. Prior to sacrificing the porcine recipient, left ventricular biopsies were taken to estimate myocardial water content and ATP levels. Persufflated hearts exhibited stroke work similar to preoperative values, whereas comparable measurements could not be obtained in static cold-stored organs due to severe arrhythmia and ventricular dyskinesia. Measurements of cardiac output, left ventricular systolic pressure and its first temporal derivative revealed that the persufflated

hearts fared significantly better than hearts stored in modified Euro-flush solution alone and had better cardiac output than hearts stored in UW solution alone. Equivalent creatine kinase levels between each group indicated that the degree of cellular damage using A-PSF may have been similar to conventional SCS. However, persufflated hearts exhibited significantly higher ATP levels than UW/Euro-flush solution-stored hearts. Collectively, these data seem to indicate that A-PSF may permit superior recovery of post-transplant heart function compared with SCS using either UW or modified Euro-flush solution. Importantly, myocardial water content measurements indicated that there was significantly less myocardial edema with A-PSF than static UW solution alone. Decreased myocardial edema is a distinct benefit of PSF, as it is known that tissue edema can significantly impair cardiac function [37]. A follow-up study examined the effects of A-PSF on myocardial tissue quality and post-transplant cardiac function by comparing against SCS in histidine-tryptophan-ketoglutarate solution with and without hyaluronidase [36]. The cohort of hearts preserved by coronary A-PSF showed significantly higher left ventricular systolic pressure and its first temporal derivative, and cardiac output compared to hearts preserved by SCS with histidine-tryptophan-ketoglutarate solution, but not when modified with hyaluronidase. Persufflated hearts maintained normal circulatory function for longer when compared to either SCS methodology. Additionally, tissue ATP levels were significantly higher in transplanted hearts following A-PSF than after SCS only. Posttransplant myocardial water content was not elevated in persufflated hearts over controls.

Up to this point, most of the research into cardiac PSF had involved experimental operations with hearts experiencing no “down-time” or conventional warm ischemia as experienced with donation after cardiac death (DCD). The opportunity to resuscitate DCD hearts inspired the group in Cologne to study PSF following warm ischemic damage. Thus, Yotsumoto et al. studied the effects of several hypothermic preservation techniques on post-transplant cardiac function following a mean warm ischemia time (WIT) of 16.7 minutes in a porcine autotransplant model [102]. Three hours of A-PSF was compared with SCS, with an additional set of controls not damaged by warm ischemia and also stored in histidine–tryptophan–ketoglutarate solution modified with hyaluronidase. As with previous studies examining the effects of preservation on heart function, a number of physiologic parameters were recorded and samples were taken to assess the metabolic recovery of the cardiac tissue. It was reported that control and persufflated hearts were completely weaned from CPB within 2 hours of transplantation, whereas the static cold-stored hearts exhibited significantly diminished functional recovery. Near the end of the 3-hour reperfusion period – cardiac output, left ventricular contractility, and the relaxation velocity were significantly higher in the A-PSF group as compared to SCS. It appeared that persufflated DCD hearts had functional outcomes similar to hearts procured from heart-beating donors using conventional storage methods. Importantly, Troponin T levels were significantly higher under SCS than for undamaged controls and hearts preserved by A-PSF at 1 hour after reperfusion. These data indicate that A-PSF may limit myocardial injury incurred during WIT. The authors noted that the transplant field is reluctant to adopt PSF as a legitimate cardiac preservation technique largely due to concerns about resulting endothelial damage. More recent studies have

shown that the coronary arteries of porcine hearts following 3 hours of oxygen A-PSF had normal functioning endothelium post-transplant [14,18,34]. Additionally, hearts transplanted following 14 hours of A-PSF exhibited no topographic signs of endothelial damage, as assessed by scanning electron microscopy [34]. Fischer has recently reviewed work done by his group, and has described the detailed experimental approach in which A-PSF is recommended as the preferred method [16]. Collectively, these works have shown that cardiac PSF has considerable potential as an emerging preservation technique, and **Table 1.2** summarizes the published work on heart PSF presented in this review.

Year	Author [Ref.]	Model(s)	Approach	WIT (min)	Duration of PSF (h)	Gas used	Temp (°C)	Primary endpoint
1902	Magnus [42]	Cat	A-PSF	-	≤1.15	O <sub>2</sub> , H <sub>2</sub> , CO <sub>2</sub>	24-28	Cardiac activity during PSF
1958	Burns [6]	Rabbit	A-PSF	-	>3	Carbogen <sup>a</sup> , N <sub>2</sub>	37	Cardiac activity during PSF
1959	Sabiston [76]	Dog	A-PSF	-	<8	Carbogen <sup>a</sup> , N <sub>2</sub>	37	Cardiac activity during PSF and after reperfusion
1960	Talbert [87]	Dog	R-PSF	-	2-7	Carbogen <sup>a</sup>	37	Cardiac activity during PSF and reperfusion
1966	Camishion [8]	Dog, Pig	R-PSF	-	<7	O <sub>2</sub> , N <sub>2</sub>	38	Cardiac activity during PSF
1966	Gabel [21]	Cat	A-PSF	-	10	Carbogen <sup>a</sup>	40	Cardiac activity and metabolic profile during PSF
1968	Lochner [40]	Guinea pig, Rat	A-PSF	-	<1.5	Carbogen <sup>a</sup>	4-37	Cardiac activity, WOOCR and metabolic profile during PSF
1998	Kuhn-Regnier [35]	Pig <sup>Tx</sup>	A-PSF	-	14.5	O <sub>2</sub>	0-1	Cardiac function and metabolic profile post-allotransplant
2000	Kuhn-Regnier [36]	Pig <sup>Tx</sup>	A-PSF	-	14.5	O <sub>2</sub>	0-1	Cardiac function and metabolic profile post-allotransplant
2003	Yotsumoto [102]	Pig (DCD) <sup>Tx</sup>	A-PSF	16.7	2.3	O <sub>2</sub>	0-1	Cardiac function and metabolic profile post-allotransplant
2001	Fischer J [14]	Pig (DCD)	A-PSF	16	3.3	O <sub>2</sub>	0-1	Coronary endothelial function
2004	Kuhn-Regnier [34]	Pig <sup>Tx</sup>	A-PSF	-	14	O <sub>2</sub>	0-1	Endothelial and myocardial cell function post-allotransplant
2004	Fischer [18]	Pig (DCD)	A-PSF	16	3.3	O <sub>2</sub>	0-1	Coronary endothelial function

<sup>a</sup> 95% O<sub>2</sub>, 5% CO<sub>2</sub>; DCD, donation after cardiac death; Tx, specifies transplant model; WOOCR, whole organ oxygen consumption rate.

**Table 1.2:**

Summary of published work on heart PSF.

## **Kidney**

The initial studies with kidney PSF occurred in the 1960s, shortly after the early development of heart PSF. It was in the kidney that PSF has been most extensively evaluated, likely because the vascular anatomy and associated transplant models are considered to be most straightforward (amongst the major transplantable organs). Following an initial study by Talbert et al. at Johns Hopkins in 1961 [88], most work on kidney PSF was performed by Fischer, Isselhard and others in Cologne, Germany. Early research efforts were comprehensive in developing the technical aspects of PSF (including optimization of flow pressures, oxygen partial pressures, temperature, and type of approach – whether antegrade or retrograde – used during kidney PSF) by evaluating their effects on the bioenergetic status and function post-reperfusion. The groundwork produced by the researchers in Cologne stimulated interest in the field and by the 1980s a number of other institutions had initiated studies to explore the value of kidney PSF.

The initial study by Talbert et al. involved in situ PSF of 7 canine kidneys [88] and showed that A-PSF with gaseous carbogen mixture (95% O<sub>2</sub> and 5% CO<sub>2</sub>) could be used to preserve kidney function for 4 hours. A-PSF was performed by feeding a catheter through the left iliac artery and positioning it at the renal artery. Once the catheter was appropriately positioned and the proximal renal artery around the catheter was sealed, the left renal vein was clamped distally and the left gonadal vein was divided and used for drainage. Once the blood was flushed using normal saline, A-PSF was started at a

pressure of 120–150 mm Hg (to expel the liquid perfusate) and gradually decreased to 80–100 mm Hg. The left kidney was persufflated for 2–4 hours, flushed with normal saline until no visual evidence of gas appeared in the venous effluent and then renal blood flow was re-established. This was performed by pulling back on the renal arterial catheter, removing the renal venous clamp and ligating the proximal stump of the left gonadal vein. The animals were then monitored for up to a year. The study included 2 sets of controls. In the first set, 4 dogs had the left renal artery isolated and clamped for 2 hours, while in the second set of controls the left renal artery was cannulated, flushed and the renal circulation was re-established after 2 hours of warm ischemia. Compared to controls, persufflated kidneys functioned for some time after the treatment. Renal function was determined primarily through intravenous pyelography and also by assessing left kidney function following contralateral nephrectomy. Furthermore, histologically, most of the persufflated kidneys exhibited some signs of tubular atrophy and scarring, but these findings were considered minimal in comparison with ischemic controls. The authors concluded that PSF has the potential to prevent the harmful consequences of warm ischemia and that the afforded protective effects are likely a result of tissue being able to utilize and survive by consumption of gaseous oxygen. They noted that simply clearing the renal vasculature of blood (to prevent coagulation during the ischemic period) was not enough to preserve organ function. These findings are highly significant in that PSF appeared to keep kidneys alive during 2 hours of WIT.

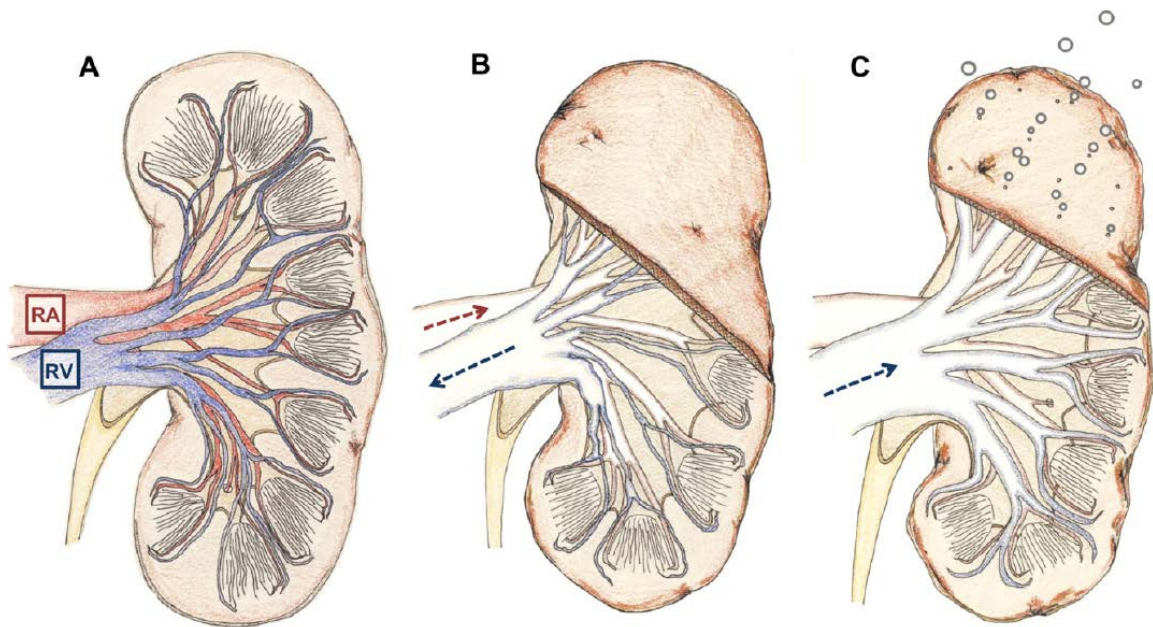
It would be 10 years before these encouraging observations reported by Talbert et al. were pursued further by others. In 1971, Denecke et al. developed an in situ canine renal



ischemia model [10], similar to the one developed by Talbert et al. [88]. This study involved a comparison between hypothermic A-PSF at 100 mm Hg and SCS. Kidneys undergoing either treatment were initially flushed clear of blood by perfusion with an unspecified crystalloid solution. Following 4 hours of A-PSF or SCS, contralateral nephrectomy was performed and circulation to the remaining experimental kidney was re-established. It was reported that A-PSF was actually more harmful to the kidneys than SCS alone; 4 of 5 dogs had died within 7 days, while the remaining dog survived but exhibited marked uremia. Of the 3 dogs having their kidneys preserved by SCS, all survived. Additionally, it was determined that persufflated kidneys had difficulty maintaining normal blood flow following the treatment, with perfusion having decreased to roughly one-third of normal. Moreover, despite an increase in tissue levels of ATP during A-PSF, the ATP levels quickly diminished following reperfusion. The authors postulated that as a result of enhanced oxygenation, the renal vasculature had responded reflexively by increasing the resistance to flow, thereby decreasing global reperfusion of the kidney. As far as we are aware, further evidence has not been provided to substantiate this claim. In our opinion, the physiological response invoked to explain these observations does not seem tenable under hypothermic conditions. It is more likely that the decrease in perfusion may have been related to vascular damage caused by hyperoxia and elevated PSF pressures. On a historical note, this was the first time that the term 'persufflation' was substituted for gaseous oxygen perfusion.

Follow-up studies resulting from this original report are important for addressing the largely unexpected outcome that A-PSF had a distinctly detrimental effect as compared

with R-PSF. Isselhard and his collaborators published a series of studies that examined the differences between A-PSF and R-PSF [28–32,77], which is PSF by delivering the gas in the direction opposite to physiologic flow (starting at the venous end). Historically, the technique of R-PSF also involved the introduction of small, pin-pricks into the surface of the organ – to facilitate gas efflux as illustrated in **Figure 1.3**.



**Figure 1.3:**

Cross-sectional illustration from the anterior view showing a native kidney (A) and kidneys being preserved by A-PSF (B) and R-PSF (C). Note the differences between A-PSF and R-PSF, in particular the relatively pronounced distension of the kidney during A-PSF and the capsular perforations only found with R-PSF – which allow for gas to escape during preservation and reduces overall resistance to gas flow.

In these studies, the effects of SCS, A-PSF and R-PSF on the bioenergetic profile of canine kidneys throughout preservation and after reperfusion were explored using their established in situ model. The degradation rate of high-energy phosphates at 37, 26 and 6 °C in canine kidneys was studied to better understand the effect of hypothermia on ATP, ADP and AMP levels. Furthermore, they measured the levels of high-energy phosphates and lactate in kidneys undergoing A-PSF and R-PSF using pure gaseous oxygen (100% O<sub>2</sub>), 40% oxygen gas (mixed with 55% N<sub>2</sub> and 5% CO<sub>2</sub>), and room air (21% O<sub>2</sub>) to also study the effects of delivered oxygen concentration. A-PSF was performed at 60 or 100 mm Hg and R-PSF at 30 or 60 mm Hg. To study the impact of preservation protocol on metabolic status, renal cortical biopsies were taken at various time-points before and during preservation and after blood flow had been re-established. ATP depletion rate dropped by a factor of 2 and nearly 10 for kidneys preserved at 26 °C and 6 °C, respectively, as compared with measurements at 37 °C. These findings confirmed that hypothermia diminishes the pace of energy utilization during storage. In the same study, Isselhard et al. were able to illustrate that the operational pressures of both A-PSF and R-PSF needed optimization for the best outcomes. ATP levels during R-PSF at 26 °C and for 8 hours were strongly dependent on the driving pressures, averaging 81% and 98% of control values at 30 and 60 mm Hg. They also reported that R-PSF was generally better at the lower pressure (30 mm Hg) than A-PSF at either 60 or 100 mm Hg, based on these metabolic assays. It also appeared that lowering the PSF pressure from 100 to 60 mm Hg during A-PSF had a stronger, negative effect on ATP metabolism than lowering the PSF pressure from 60 to 30 mm Hg during R-PSF. The authors specifically stated that pressures below 60 mm Hg were unable to sustain adequate gas flow during A-PSF and

they also pointed out that the rate at which ATP was degraded increased inversely with gaseous oxygen concentration. Not surprisingly, lactate levels rose as the oxygen concentration decreased (from 100% to 40% and 21%) in both A-PSF (at 60 mm Hg) and R-PSF (at 30 mm Hg), but more dramatically during A-PSF. A remarkable accomplishment was the demonstration that ATP levels were maintained at 40% and 30% of control values under A-PSF (at 60 mm Hg, 66 hours) and R-PSF (at 30 mm Hg, 72 hours) at 6 °C, respectively. In contrast, during SCS – ATP levels were reduced to negligible levels within minutes. These investigators noted that despite an ability to maintain a healthy bioenergetic status in preserved kidneys by PSF, the energy disparity (between utilization and production) remains during hypothermic storage and is only slowed down. Further studies by this group remained focused on the important differences between A-PSF and R-PSF, by assessing their effects on renal bioenergetic status and function after reperfusion [29,32]. In situ A-PSF (at 90–100 mm Hg) was performed on canine kidneys for 4 hours at 6 °C. Following the preservation period, a contralateral nephrectomy was carried out and the treated kidneys were reperfused. These persufflated kidneys were compared with healthy control kidneys and kidneys preserved by SCS for 4 hours and at 6 °C. In summary, it was shown that A-PSF was better at maintaining ATP levels than SCS alone. However, once blood flow was restored, kidneys preserved by A-PSF fared no better. 60 minutes after reperfusion, static cold-stored kidneys restored their ATP to levels comparable to those achieved following A-PSF. It was observed that kidneys preserved by A-PSF exhibited healthy levels of ATP during the first 30 minutes of reperfusion, but that deterioration quickly ensued. The authors attributed this fall in ATP to the development of poor intrarenal blood flow following

reperfusion and speculated that the cause was damage inflicted on glomerular vessels during A-PSF. *In vivo* renal function studies yielded findings that supported the belief that filtration had been most affected. Within 8 days, all dogs having a kidney preserved by A-PSF had died, while all dogs in the SCS control group survived. A progressive decline in renal function was documented through failing urine production, uremia and systematic elevation in serum creatinine. The glomerular filtration rate and renal plasma flow had dropped drastically by post-operative day (POD) 2 in all animals that died following A-PSF. Following this study, Isselhard pursued an identical study using R-PSF and, in contrast to A-PSF, R-PSF for 4 hours at 30 mm Hg did not result in the same deterioration in kidney function. ATP levels remained similar after 60 minutes of reperfusion, were no different from healthy controls, and better than static cold-stored controls. Furthermore, serum urea and creatinine values were generally lower following R-PSF than with SCS, but remained above baseline at POD 10. Glomerular filtration rate and renal plasma flow were normalized by POD 2 in persufflated kidneys, but static cold-stored kidneys did not fully normalize until POD 21, highlighting the accelerated recovery of renal function following R-PSF. As a direct result of these studies, the Cologne group primarily adopted R-PSF as the most promising of these approaches.

In the mid-to-late 1970s, Fischer's group contributed some of the most fundamental work on kidney PSF. In 1978, Fischer et al. presented a study in which the functional recovery of kidneys was documented after 2 or 30 minutes of WIT and following 24 hours of R-PSF, all of which preceded heterotopic autotransplantation into dogs [17]. For this, the authors developed a unique model where a contralateral nephrectomy was not used to

isolate the functional output of each kidney – rather the preserved kidney was by transplanted into the collar region while the contralateral kidney was left in the retroperitoneum. It was demonstrated that 24 hours of R-PSF, in the presence of up to 30 minutes of WIT, was capable of preserving post-transplant renal function. Key measurable parameters of kidney function were glomerular filtration rate and renal plasma flow during a 3-hour period following transplantation. In kidneys subjected to only 2 minutes of WIT, the persufflated and autotransplanted kidney exhibited mean glomerular filtration rate and renal plasma flow that were 46% and 56% of the healthy contralateral kidney, respectively. Similarly, in kidneys undergoing 30 minutes of WIT – the preserved kidney had mean values of glomerular filtration rate and renal plasma flow that were 32% and 49% of the healthy control during the observation period. These results demonstrated that *ex vivo*, hypothermic R-PSF for 24 hours can preserve renal function in the face of considerable WIT (30 min). At the same time, Isselhard suggested that the duration of cold preservation by R-PSF could possibly be extended even further, up to 48 hours [27] leading to a new line of investigation. In summary, they found that R-PSF maintained ATP levels for up to 120 hours. A more significant finding was that 30 minutes of WIT did not have as profound an effect on the ability of R-PSF to resuscitate the organ. ATP levels were monitored for 72 hours and were maintained at levels comparable to kidneys not damaged by warm ischemia. As cold ischemia time was prolonged, the capacity for aerobic metabolism measurably decreased but it was apparent that R-PSF may extend the life of kidneys during cold preservation.

At this point, the reported merits of PSF had not been tried clinically. However, in 1975, Flatmark et al. described a short study in which they reported their experiences with the accidental gas perfusion of human kidneys during HMP [19]. These kidneys were preserved in SCS (at 4 °C, for 4–7.5 hours), transported from the site of procurement and then started on machine perfusion (at 8–10 °C, with the perfusate equilibrated to 66% N<sub>2</sub>, 33% O<sub>2</sub> and 1% CO<sub>2</sub>) once received at their institution in Oslo. At some time after the start of HMP (between 3 and 12.5 hours), leaks were discovered near the oxygenator, which allowed air to be pulled into the flow circuit. In each of 4 kidneys the leak persisted and these organs were persufflated with air for about 60–120 minutes. Once the leak was identified, liquid perfusion was re-established and continued for the remainder of cold preservation, or 2–18.5 hours. Each kidney was subsequently transplanted, all produced urine immediately and most achieved healthy renal function by 4 weeks post-operatively. One of the 4 patients unfortunately died, but the cause of death was not reported. In conclusion the authors stated that PSF (which they referred to as ‘massive gas embolization’) for up to 2 hours did not adversely affect post-transplant renal function. This was the first time that PSF was performed on human organs, albeit inadvertently.

The significant contributions of the Cologne group provided inspiration for other scientists to pursue this field of investigation. In Australia, Ross and Escott explored 24-hour PSF of canine kidneys following 30 minutes of WIT and the effects of PSF on heterotopic autotransplant outcomes [70,71]. These studies focused on how the composition of the gaseous perfusate affected post-transplant renal function and survival.

Also, these investigators tried persufflating via the ureter for the first time. Three interesting observations were reported: First, that R-PSF was better at preserving renal function than A-PSF, as measured by serum creatinine values post-transplant. Second, that carbogen (95% O<sub>2</sub>, 5% CO<sub>2</sub>) may be better than pure oxygen gas (100% O<sub>2</sub>) in normalizing renal function post-transplant. Third, that ureteral PSF may work, but that it needs further exploration. One puzzling finding from these studies was the relatively high incidence of intravascular thrombosis in all groups studied. They had postulated that it may have been due to endothelial damage resulting from a gas-drying effect, yet the greatest incidence of thrombosis occurred in the group receiving humidified pure oxygen gas. Traumatic damage to the vasculature may have been an alternative explanation. An explanation not explicitly considered was the possibility of endothelial damage resulting from hyperoxia.

During this same era, Pegg and his group in Cambridge, England published a series of studies exploring the utility of PSF in kidney preservation. This group developed a fairly elaborate canine autotransplantation model that they used to examine the effects of varying lengths of WIT (30 and 60 min) in combination with R-PSF for 24 or 48 hours duration [64, 68, 69]. They also explored the differences between pure oxygen, air, nitrogen and helium PSF on post-transplant renal function and survival (for up to 3 months). It was reported that no kidney transplanted after 60 minutes of WIT and 24 hours of SCS was able to sustain recipient survival. On the contrary, R-PSF with pure oxygen gas was capable of sustaining longterm renal function and survival in most recipients. When air was substituted for oxygen, kidneys remained functioning, but the



survival rates decreased. R-PSF with nitrogen and helium gases generated results similar to kidneys preserved by SCS. Kidneys that had undergone 30 minutes of WIT and 48 hours of cold ischemia time performed significantly better post-transplant, particularly if they had been persufflated; most animals (80% of group) survived R-PSF, while only a single animal (20% of group) survived following transplantation of a control kidney. Another noteworthy finding was that they were not able to establish any differences in total adenine nucleotide content between persufflated and control kidneys, or between kidneys persufflated for 24 versus 48 hours or with different gases. One explanation is that the authors do not report ATP, ADP or AMP levels, but rather total adenine nucleotide content, which is the sum of these three; it is possible that the individual ATP and ADP fluctuations are masked by their summation. It is also important to note that the R-PSF pressures used in their study were particularly low, which may have resulted in inadequate PSF of the entire organ. This may be corroborated by the better outcomes using pure oxygen gas rather than air. Since the total adenine nucleotide content measurements are derived from tissue processed following biopsy, it is possible that the sampled regions of the kidney were poorly persufflated or that these samples do not reflect real-time total adenine nucleotide content levels because the tissue processing involves several steps and takes some time. Nevertheless, these data are compelling because the authors raise very reasonable questions regarding the interpretation of ATP and ADP measurements and their use as accurate predictors of metabolic quality in organ preservation. It has been widely appreciated that high energy phosphates recycle rapidly and that a single measurement is only a snapshot into the tissue metabolic status that does

not necessarily provide information regarding the ability of tissue to recover from an insult [86].

The Cambridge group also published a follow-up pilot study in which a number of DCD human kidneys were persufflated prior to transplantation and compared with static cold-stored kidneys post-transplant in a paired fashion (meaning that each donor provided 1 kidney for R-PSF and another for SCS) [69]. The average WIT was 55 min, whereas the average cold ischemia time was 21.5 hours. The persufflated organs performed better post-transplant, exhibiting a mean onset of function at  $8.4 \pm 2.6$  days versus  $13.9 \pm 1.4$  days in the paired controls. Furthermore, the reported mean serum creatinine levels at POD 15 were 457 and 826  $\mu\text{M}$  for the R-PSF and SCS groups, respectively. It was also explained that cyclosporine was largely omitted from the immunosuppressive regimen in order to limit the impact of calcineurin inhibitor-associated nephropathy on the study results. Even so, of the 6 recipients that received cyclosporine, 4 of them received a kidney that was preserved by R-PSF. This first clinical study exploring R-PSF in preserving DCD kidneys illustrated that: (1) R-PSF can be executed within the current clinical infrastructure, including timeframe; and (2) R-PSF also exhibits the ability to resuscitate organs that have suffered from significant warm ischemia. Collectively, these 2 observations suggest that R-PSF may be easily implemented and could make more DCD organs suitable for transplant.

In an attempt to further elucidate the mechanism of preservation by PSF, Pegg et al. carried out an interesting study in 1989 in which they compared 24 hours of SCS to 24 hours of R-PSF following 60 minutes of WIT in an *ex vivo* rabbit kidney model [64].

Their hypothesis was that gaseous oxygen PSF enables continued aerobic respiration and that hypothermic conditions only slow the rates governing energy turnover. They studied ATP levels following R-PSF in conjunction with pharmacologic treatment with ouabain or cyanide/iodoacetate. Concomitant administration of ouabain, a potent sodium pump inhibitor, led to elevated ATP levels over R-PSF controls, which exhibited significantly higher ATP levels if compared with kidneys preserved by SCS. Conversely, treatment with cyanide/iodoacetate resulted in a fall of ATP, below levels present in static cold-stored kidneys. These measurements confirmed that if oxygen is available, even as a gas at low temperatures, it will be consumed by viable tissue. If pumps that consume ATP, like the  $\text{Na}^+/\text{K}^+$ -ATPase, are actively blocked, ATP levels will transiently rise, suggesting that ‘new’ ATP has been produced. On the contrary, if the electron transport chain is inhibited, then the capacity to generate ATP drops and the available oxygen supply will not be consumed. These findings provided insight into the mechanistic principles governing oxygen consumption. Histology and electron microscopy revealed that renal tissue after R-PSF exhibited cellular damage over smaller foci and were largely surrounded by healthy tissue. Intriguingly, electron micrographs were capable of discriminating between the “orthodox” (energized) mitochondrial configuration present in persufflated samples and the “condensed” (de-energized) mitochondria of the cold-stored tissues [64]. As a whole, these findings support the belief that R-PSF can maintain renal tissue viability and prevent irreversible injury during prolonged cold storage.

During this time, Stowe et al. at the Cleveland Clinic pursued *ex vivo* R-PSF in conjunction with a canine autotransplantation model [84]. After resecting the left kidney

and flushing immediately with chilled lactated Ringers solution, R-PSF was performed for 48 hours (at 4–5 °C and 7–10 mm Hg). Two days following the start of cold preservation, a contralateral nephrectomy was performed and the preserved kidney was transplanted heterotopically. Only 25% of animals that were autotransplanted with kidneys preserved by SCS or R-PSF survived to POD 22. In addition to comparing R-PSF with SCS, 3 animals received an intramuscular dose (500 mg) of deferoxamine mesylate. All 3 animals receiving a kidney preserved by R-PSF and treated with intramuscular deferoxamine mesylate survived to POD 22. In general, persufflated kidneys exhibited better overall renal function than static cold-stored kidneys. Though the total number of transplants was low, it appeared that deferoxamine mesylate contributed to an elevated survival rate posttransplant. The authors postulated that this was possibly due to free radical-scavenging activity in deferoxamine mesylate.

Several years later, Kootstra's group at the University Hospital in Maastricht addressed the question of whether the presence of adenosine benefits the quality of warm ischemically-damaged (30 minutes of WIT) and preserved rat kidneys during both R-PSF and SCS [101]. Yin et al. used UW solution containing exogenous adenosine and UW solution with no adenosine. All kidneys, whether preserved by 24 hours of R-PSF or SCS, were flushed with either of these UW solutions [101]. In brief, they determined that regeneration of ATP was not affected by the presence of adenosine in UW solution. The authors postulated that since the levels of hypoxanthine (degradation product of adenosine) were significantly higher in renal tissue preserved with exogenous adenosine than in tissue without, that most of the additionally available adenosine was degraded in

the tissue and not used in the direct replenishment of ATP. However, hypoxanthine levels were significantly lower in persufflated kidneys than in static cold-stored kidneys, which were also flushed with adenosine-containing UW solution. Alternatively, it may be that adenosine found in the preservation solutions may not be able to cross the plasma membranes of viable cells. The authors also went further by transplanting 20 kidneys, 10 from each of the R-PSF and SCS groups. They reported that none of the rats transplanted with static cold-stored kidneys survived, whereas 3 of the rats transplanted with retrogradely persufflated kidneys survived an observation period of 2 weeks. Because the survival rates between the 2 groups were not significantly different, they concluded that singular measurements of ATP during the preservation period may not predict survival outcomes. These conclusions were similar to those generated at Cambridge [68]. However, a point of caution must be raised regarding the choice in animal model. In general, PSF (or HMP, for that matter) will impart its greatest benefit if an organ is large and cannot obtain adequate oxygen by passive diffusion from the surface alone. In other words, success in a rat model may not be comparable to the human clinical situation because of significant size disparity. This scaling problem has already been encountered when comparing the rat and porcine pancreata during SCS [63]. Rat data must be interpreted with appreciation for oxygen transport limitations, especially when trying to translate outcomes from animal models into the clinical arena.

Finally, more recently, Treckmann built upon the work of his predecessors and published studies that highlight the promising prospects of clinical PSF [96, 97]. In 2006, Treckmann et al. used a porcine autotransplantation model to show that R-PSF of kidneys

damaged by significant WIT, when compared with conventional SCS, may yield improved survival [97]. Left kidneys from porcine donors were clamped off in situ for 60–120 minutes of WIT, resected, flushed anterogradely, preserved by R-PSF or SCS for 4 hours and autotransplanted. They demonstrated that all animals transplanted with persufflated kidneys after 60 minutes of WIT survived the 7-day observation period, with robust renal function. Animals receiving a similarly-treated kidney but stored by SCS survived in 57.1% of cases. This paired comparison was also performed for both 90 and 120 minutes of WIT, but did not reveal strong differences between R-PSF and SCS, at least in terms of post-transplant survival. It is important to note that only the persufflated kidneys received a pre-treatment of superoxide dismutase (SOD), which had been determined from their earlier liver work, to help protect against the oxidative damage caused by hyperoxia and reperfusion [49]. A follow-up study compared R-PSF and HMP, using the same porcine autotransplant model; 13 kidneys were resected following 60 minutes of WIT and preserved by SCS, HMP or R-PSF following pre-treatment with SOD [96]. Results showed that all indicators of renal function were significantly better in persufflated kidneys versus HMP and static cold-stored kidneys at POD 7. Recipient survival after 7 days was 57%, 60% and 100% after transplantation of kidneys preserved by SCS, HMP and R-PSF, respectively. These results in the larger animal model suggest that R-PSF is a promising way to maintain organ quality in DCD kidneys, particularly because R-PSF was directly compared against the already clinically-accepted HMP and performed comparably if not better. The collective work performed on kidney PSF has been summarized in **Table 1.3**.

Year	Author [Ref.]	Model	Approach	WIT (min)	Duration of PSF (h)	Gas used	Temp (°C)	Primary endpoint
1961	Talbert [88]	Dog	A-PSF	-	2-4	Carbogen <sup>a</sup>	37	Renal function after reperfusion, gross and microscopic morphology
1971	Denecke [10]	Dog	NS	-	4	O <sub>2</sub>	6	Renal function and metabolic profile after PSF and during reperfusion
1972	Isselhard [28]	Dog	A-PSF, R-PSF	-	2-72	O <sub>2</sub> , Air, Mixture <sup>b</sup>	6, 26	Metabolic profile during PSF
1973	Isselhard [29]	Dog	A-PSF	-	4	O <sub>2</sub>	6	Renal function and metabolic profile after PSF and during reperfusion
1974	Isselhard [32]	Dog	R-PSF	-	4	O <sub>2</sub>	6	Renal function and metabolic profile after PSF and during reperfusion
1975	Flatmark [19]	Human <sup>Tx</sup>	A-PSF	-	1-2	Air	4	Renal function post-allotransplant
1978	Fischer [17]	Dog <sup>Tx</sup>	R-PSF	2, 30	24	O <sub>2</sub>	6	Renal function post-autotransplant (into neck, with no contralateral native nephrectomy)
1978	Isselhard [27]	Dog <sup>Tx</sup>	R-PSF	30	24, 48, 72	O <sub>2</sub>	NS	Renal function post-autotransplant
1979	Ross [70]	Dog <sup>Tx</sup>	A-PSF, R-PSF	30	24	O <sub>2</sub>	NS	Renal function post-autotransplant
1982	Ross [71]	Dog <sup>Tx</sup>	R-PSF, Ureteral	-	48	O <sub>2</sub> , Carbogen <sup>a</sup> , Air	NS	Renal function post-autotransplant
1984	Rolles [68]	Dog <sup>Tx</sup>	R-PSF	30, 60	24, 48	O <sub>2</sub> , Air, N <sub>2</sub> , Helium	0-6	Renal function post-autotransplant
1986	Stowe [84]	Dog <sup>Tx</sup>	R-PSF	-	48	O <sub>2</sub>	4-5	Renal function post-autotransplant
1989	Rolles [69]	Human (DCD) <sup>Tx</sup>	R-PSF	13-80	15-27	O <sub>2</sub>	0	Renal function post-allotransplant
1989	Pegg [64]	Rabbit	R-PSF	60	24	O <sub>2</sub>	0	Mechanistic evaluation of oxygen utilization and morphology before and after PSF
1996	Yin [101]	Rat (DCD) <sup>Tx</sup>	R-PSF	30	24	O <sub>2</sub>	4	Metabolic profile before and after PSF, renal function post-allotransplant, and evaluation of exogenous adenosine in cold preservation solution
2006	Treckmann [97]	Pig <sup>Tx</sup>	R-PSF	60, 90, 120	4	O <sub>2</sub>	4	Renal function post-autotransplant
2009	Treckmann [96]	Pig <sup>Tx</sup>	R-PSF	60	4	O <sub>2</sub>	4	Renal function post-autotransplant, comparison with HMP

<sup>a</sup> 95% O<sub>2</sub>, 5% CO<sub>2</sub>.

<sup>b</sup> 55% N<sub>2</sub>, 40% O<sub>2</sub>, 5% CO<sub>2</sub>; DCD, donation after cardiac death; NS, not specified; Tx, signifies transplant model.

**Table 1.3:**

Summary of published work on kidney PSF.

## **Liver**

PSF was tested for the first time in rat livers around 1980 by Fischer's group at the University of Cologne [15], but was not studied in depth (by the same group) until the 1990s. Initial work revolved around establishing that livers damaged by prolonged WIT could be resuscitated using R-PSF. Each liver in the R-PSF cohort was flushed with cold preservation solution and R-PSF was performed by administering gaseous oxygen at 18–30 mm Hg via a hepatic vein, while providing an escape route for the gas by introducing small, pin-sized holes on the liver surface. They reported that 24 hours of R-PSF resulted in no detectable lactate accumulation, but a substantial decrease in glycogen content.

It was during this period that anti-oxidants were identified and used to provide additional value in preservation using R-PSF, by conferring improved hepatocellular integrity and function following reperfusion [49]. In the 1990s, the same group extended some of their *in vitro* studies into small animal (rat) and large animal (pig) liver transplant models. They showed that poorer quality livers could be revived to function successfully post-transplant. As recently as 2008, the same researchers showed that clinical PSF is possible; having a cohort of 5 patients transplanted with persufflated livers and showing no adverse effects and strong graft function [94]. Another interesting niche for PSF has been in the conditioning of a liver near the end of the preservation period, in so-called end- or post-ischemic conditioning [56]. As it stands, liver PSF is actively being explored and the preceding 3 decades of work highlights some of the reasons why.



In 1993, Minor et al. studied reperfusion injury in the rat liver following an ischemic period during preservation [49]. They procured a number of rat livers, flushed sequentially with lactated Ringers and Euro-Collins solutions via the hepatic vein, and bathed the organ in Krebs–Henseleit solution at 37 °C for 60 minutes. After the controlled duration of WIT, the liver was submerged in Euro-Collins solution at 4 °C and stored for another 60 minutes. Following static storage alone, the organs underwent normothermic (37 °C) R-PSF for 30 minutes and were subsequently flushed with lactated Ringers solution. Persufflated organs received some combination of antioxidant pre-treatment, either a bolus injection of allopurinol prior to ischemia and/or the addition of allopurinol or SOD into the flushing solution. At the end of the 2.5-hour treatment, the liver was flushed with lactated Ringers solution via the infrahepatic caval vein. The effluent was collected and analyzed for ATP and total adenine nucleotide content. The authors also determined the amount of malondialdehyde accumulated (via free radical-induced lipid peroxidation) and the amounts of liver enzymes released by damaged hepatic parenchyma. It was reported that R-PSF of the liver was capable of partially reversing ATP levels after 120 minutes of combined warm and cold ischemia. Additionally, it was shown that pre-treatment with anti-oxidants decreased the degree of lipid peroxidation and improved ATP recovery with R-PSF. Samples from persufflated livers pre-treated with allopurinol/SOD revealed that gaseous PSF alone can harm the liver due to oxidative damage, but also highlighted the potential of anti-oxidant administration as an adjunctive therapy.

In a follow-up study, the same group showed that early administration of R-PSF reduces lipid peroxidation and may actually suppress the adverse effects of free-radical damage [46]. The authors speculated that immediate PSF may prevent damage by enabling the preservation of free-radical scavenging activity, which itself can require energy. Two years later this concept was studied in more depth using a rat liver reperfusion model [47,48]. The effect of R-PSF in suppressing ischemia-reperfusion injury was compared to preservation with 48 hours of SCS in UW solution at 4 °C and followed by a 30 minutes period of re-warming with normal saline at 25 °C. Reperfusion consisted of pre-oxygenated (95% O<sub>2</sub>, 5% CO<sub>2</sub>), re-circulating Krebs–Henseleit solution delivered through the portal vein for up to 45 minutes. The effluent was analyzed and it was reported that endothelial and hepatic parenchymal damage was lowered and that activation of Kupffer cells was reduced in livers that had been persufflated. These findings suggested that R-PSF may avoid disturbances in perfusion (like higher portal venous pressures) that result from damage to vessels. In addition, ATP concentrations were higher in persufflated livers than in static cold-stored livers and, at different times throughout the reperfusion, comparable to fresh control livers that were not subjected to cold storage. It was interesting to note that livers preserved by R-PSF exhibited significantly greater ATP levels as compared to reference values obtained from native rat liver [47].

These studies were extended to evaluate whether R-PSF in combination with SOD preconditioning would resuscitate the DCD rat liver, harvested after 30 minutes of WIT [50]. Livers are known to be poorly resistant to warm ischemic damage [93]. In fact, outcomes

following DCD liver transplant have been strongly tied to the extent of warm ischemic injury [66, 67, 93]. In this study, DCD livers preserved for 24 hours with R-PSF appeared to be healthier when compared with livers preserved by SCS in UW solution. The extent of lipid peroxidation was found to be lower in the R-PSF cohort. Interestingly, bile production and ATP levels were higher, while endothelial damage and portal perfusion pressures were lower than even fresh controls following 45 minutes of reperfusion with pre-oxygenated Krebs–Henseleit solution. It appeared that the putative, harmful effects of high oxygen concentrations during R-PSF could be prevented with the help of anti-oxidant treatment and resuscitation of livers from DCD was possible using R-PSF.

In 1997, Minor et al. introduced a novel rat liver transplant model [52] in which rat livers were preserved with SCS alone or R-PSF. The hypotheses they tested was the proposal that R-PSF limited proteolytic degradation of the liver, believed to contribute to hepatocellular injury during SCS, and that R-PSF would result in improved post-transplant indicators such as decreased plasma levels of malondialdehyde, decreased alanine aminotransferase, increased bile production and increased hepatic tissue perfusion. Proteolysis was estimated by a measured tissue content of free L-alanine. Twenty-four hours of SCS in UW solution resulted in significantly higher concentrations of free L-alanine than fresh (nonstored) controls, while R-PSF seemed to prevent some proteolysis. Following *in vivo* reperfusion, Minor et al. reported that both the static cold-stored only and persufflated livers experienced decreased hepatic perfusion initially, but that the persufflated organs exhibited an overall better recovery. Furthermore, plasma levels of malondialdehyde and alanine aminotransferase were significantly lower in the

livers having undergone R-PSF, but still elevated in both, while hepatic bile production was significantly increased in persufflated livers and comparable to fresh controls. It was concluded that R-PSF may help the ischemic liver obviate some of the ill-effects of hypoxia (like activation of cytosolic proteases and autolysis) by maintaining a more favorable metabolic condition. The authors reiterated that protecting tissue from oxidative damage necessitates sufficient energetic support, fueled by an adequate oxygen supply.

In the same year, Minor et al. examined the effect of lower pressure (9 mm Hg) versus higher pressure (18 mm Hg) R-PSF and the use of both pure gaseous oxygen and air [53]. The effectiveness and homogeneity of the R-PSF was studied by detecting autofluorescence of nicotinamide adenine dinucleotide [54, 55, 59], accumulated primarily in anoxic tissue. The reason why R-PSF was traditionally performed at 18 mm Hg of pressure was arbitrary; it had been determined that it was the pressure required for visual detection of bubbles escaping from the surface of the perforated liver. Nonetheless, interrogation at 1 and 24 hours after the start of cold preservation revealed that R-PSF at 9 and 18 mm Hg resulted in a comparable and significant decrease in nicotinamide adenine dinucleotide over static cold-stored controls. On the other hand, R-PSF with air at 18 mm Hg did not decrease detected nicotinamide adenine dinucleotide levels below those detected in livers on SCS, suggesting that air may not provide adequate oxygen during liver PSF.

Following the extensive studies in rat livers, translation of PSF into a larger animal model was the next step. In 1998, Minor et al. described work in which recipients were allotransplanted with DCD porcine livers following 1 of 2 preservation protocols [57]. All livers were harvested after 45 minutes of in situ WIT in a non-heparinized donor. Using the first protocol, the donor livers were flushed with heparinized normal saline and UW solution via the portal vein and stored on UW solution at 4 °C for 4–5 hours. With the second protocol, the donor livers were also flushed with heparinized normal saline and UW solution, but the last 100 mL of UW solution used to flush the liver was spiked with SOD. Following the flush, R-PSF was initiated via the inferior vena cava for 4–5 hours. After the period of cold preservation, the stored livers were orthotopically transplanted into recipients. Shortly following transplantation, it was determined that SCS alone was not able to adequately preserve DCD livers; all 5 recipients died in the early post-transplant course. On the other hand, all livers stored by R-PSF were capable of normalizing ammonia levels by POD 1 and aspartate aminotransferase plasma levels by POD 7.

In a follow-up study, the same investigators again compared SCS and R-PSF/SOD preservation by measuring plasma levels of aspartate aminotransferase, alanine aminotransferase, lactate dehydrogenase and clotting times at 1-hour post-transplant, with the primary endpoint of recipient survival at POD 5 [75]. DCD livers underwent 60 minutes of WIT prior to 4 hours of SCS with UW solution or R-PSF and pre-treatment with SOD. All DCD transplants were compared with control livers resected and transplanted immediately following cardiac arrest. They reported that UW-stored livers

fares poorly post-transplant, accounting for significantly higher plasma hepatic enzyme levels, lactate dehydrogenase and prolonged partial thromboplastin time, suggesting that the liver had incurred significant hepatocellular injury during the preservation. Additionally, all of the animals receiving such livers died within 3 hours of reperfusion. On the contrary, animals receiving livers preserved by R-PSF/SOD survived the observation period. Impressively, it was stated that persufflated porcine DCD livers performed comparably to fresh livers during the post-transplant course. Since very few DCD livers are transplanted nowadays, making more DCD livers available for transplant would reduce the numbers of patients on liver transplant waiting lists.

Around the same time PSF was being used in the resuscitation of DCD livers, Minor et al. explored an interesting application of PSF in pre-conditioning the long-term, static cold-stored liver for reperfusion [56]. In his first study on this topic, rat livers were subjected to either 48 hours of SCS on UW solution or 47 hours of SCS on UW solution followed by R-PSF for 60 minutes. Each of the organs were then warmed and reperfused in vitro for 45 minutes. Following reperfusion, livers conditioned (with R-PSF) fared significantly better – exhibiting decreased parenchymal enzyme levels and portal venous pressures, and improved bioenergetic status. It is believed that the delivery of gaseous oxygen prior to reperfusion may prevent edema formation due to the improvement in metabolic condition of the organ. Additionally, it may be that free-radical scavenging activity has been depressed during SCS and that preconditioning for reperfusion using PSF helps provide the oxygen necessary for replenishment of such activity [56,58].

The concept of using PSF to condition for reperfusion was studied more than a decade later for the preservation of fatty rat livers [58]. In these most recent studies, R-PSF for 90 minutes following 20 hours of SCS decreased hepatic parenchymal enzyme release, lipid peroxidation, cellular apoptosis and autophagy, and improved the functional clearance of ammonia, microscopic morphology and overall metabolic status of these livers as compared with unconditioned livers. These preliminary studies illustrate that post-ischemic conditioning of preserved organs prior to transplant is an area meriting further study.

With anti-oxidant therapy having already been explored for use with PSF [49,50,57,75], it became apparent that continued success using PSF in preservation may require protection against reperfusion injury. In 2003, Lauschke et al. studied the effect of administering taurine or SOD prior to R-PSF [38]. These studies employed a DCD rat model in which the livers were resected following 60 minutes of WIT and preserved either by SCS in UW solution, by R-PSF/taurine, or by R-PSF/SOD for 24 hours. Following the preservation period, livers were reperfused in vitro using Krebs–Henseleit solution maintained at 37 °C for 45 minutes. Analysis of the effluent at the end of the reperfusion period revealed that livers treated with anti-oxidant exhibited decreased enzyme release and portal vascular resistance, and increased bile production. Interestingly, taurine and SOD appeared to have a similar protective effect for DCD livers in the face of ischemia–reperfusion. Future work to enhance the successful application of PSF for all organs of interest may require the identification of the appropriate anti-oxidant, dose(s) and schedule.

Most recently, Treckmann and colleagues have taken a major step, by translating R-PSF into the human clinical setting. In 2008, they reported results from a pilot study using R-PSF to resuscitate 5 DCD human livers between April 2004 and March 2005 [94]. These donor cadaveric livers were estimated to have undergone anywhere from 20–60 minutes of WIT and the donors had expired after failed attempts at cardiopulmonary resuscitation or having experienced prolonged periods of hypoperfusion (<60 mm Hg). It is also important to note that these donor livers were rejected for transplant by at least 3 different centers. The livers were procured off-site, perfused with UW solution and histidine–tryptophan–ketoglutarate solution, and then shipped to the transplant center. After establishing recipient consent, the livers were additionally flushed with UW solution containing N-acetylcysteine and were retrogradely persufflated at 18 mm Hg for 70–200 minutes prior to orthotopic transplantation. The results of the transplants were encouraging in all cases. All patients survived and none of the patients required a re-transplant; all patients were alive, with strong graft function, at a minimum of 2 years follow-up. Histologic evaluation was performed on biopsies taken immediately prior to and after R-PSF and directly following reperfusion. Analysis revealed that R-PSF did not appear to cause any vascular damage to the liver. Additionally, it was shown that PSF had recovered ATP levels by 2–5 times the pre-PSF measurements. These data are highly encouraging, especially considering the potential impact that PSF could have in expanding DCD liver transplantation. **Table 1.4** summarizes the published work on liver PSF presented in this review.



Year	Author [Ref.]	Model	Approach	WIT (min)	Duration of PSF (h)	Gas used	Temp (°C)	Primary endpoint
1980	Fischer J [15]	Rat	R-PSF	-	24	O <sub>2</sub>	6	Metabolic profile after PSF
1993	Minor T [49]	Rat	R-PSF	60	0.5	O <sub>2</sub> , N <sub>2</sub>	37	Hepatic injury and metabolic state before and after PSF, evaluation of anti-oxidant treatment after PSF
1994	Minor T [46]	Rat	R-PSF	60	1	O <sub>2</sub>	4, 37	Hepatic injury, oxidative state and metabolic profile after reperfusion
1996	Minor T [48]	Rat	R-PSF	30 <sup>a</sup>	48	O <sub>2</sub>	4	Hepatic injury after reperfusion, endothelial activity and WOOOCR
1996	Minor T [47]	Rat	R-PSF	30 <sup>a</sup>	48	O <sub>2</sub>	4	Metabolic profile after PSF and during reperfusion
1996	Minor T [50]	Rat (DCD)	R-PSF	30 <sup>a</sup>	24	O <sub>2</sub>	4	Hepatic injury and metabolic profile during reperfusion
1997	Minor T [52]	Rat <sup>Tx</sup>	R-PSF	-	24	O <sub>2</sub>	4	Assessment of proteolysis after PSF, hepatic function, perfusion, injury and oxidative state post-allotransplant
1997	Minor T [53]	Rat	R-PSF	-	24	O <sub>2</sub> , Air	4	Hepatic oxygenation during PSF
1997	Minor T [55]	Rat (DCD)	R-PSF	60	2	O <sub>2</sub>	12	Hepatic function, injury and metabolic profile after reperfusion
1997	Minor T [54]	Rat <sup>Tx</sup>	R-PSF	-	24	O <sub>2</sub>	4	Hepatic oxygenation during PSF, metabolic profile after PSF, hepatic injury post-allotransplant
1998	Minor T [59]	Rat	R-PSF	-	24	O <sub>2</sub> , Air	4	Hepatic oxygenation before and after PSF
1998	Minor T [56]	Rat	R-PSF	30 <sup>a</sup>	1	O <sub>2</sub>	4	Hepatic function, injury and metabolic profile following post-ischemic conditioning using PSF and during reperfusion
1998	Minor T [57]	Pig (DCD) <sup>Tx</sup>	R-PSF	45	4-5	O <sub>2</sub>	4	Hepatic function, injury post-allotransplant
2001	Saad S [75]	Pig (DCD) <sup>Tx</sup>	R-PSF	60	4	O <sub>2</sub>	4	Hepatic function, injury post-allotransplant
2003	Lauschke H [38]	Rat (DCD) <sup>Tx</sup>	R-PSF	60	24	O <sub>2</sub>	4	Hepatic function, injury and oxidative state after reperfusion, evaluation of anti-oxidant pre-treatment during PSF
2008	Treckmann J [94]	Human (DCD) <sup>Tx</sup>	R-PSF	20-60	1.2-3.3	O <sub>2</sub>	4	Metabolic status before and after PSF, hepatic function and injury post-allotransplant
2009	Minor T [58]	Rat	R-PSF	20 <sup>a</sup>	1.5	O <sub>2</sub>	4	Hepatic function, injury, oxidative state and metabolic profile following post-ischemic conditioning using PSF and during reperfusion

<sup>a</sup> Re-warming period prior to reperfusion; DCD, donation after cardiac death; Tx, signifies transplant model; WOOOCR, whole organ oxygen consumption rate.

**Table 1.4:**

Summary of published work on liver PSF.

### **Small bowel and pancreas**

To date, the pancreas and small intestine have not been studied extensively as targets of PSF. In 1997, Minor et al. published the only known work on luminal gas oxygenation of the small bowel [51]. Rat jejunal segments (15-cm in length) along with the vascular pedicle were harvested and stored in UW solution at 4 °C for 18 hours and half of the experimental organs underwent low-pressure, luminal gas oxygenation. Following the experimental storage period, intestinal absorption was estimated by introducing galactose to the lumen and measuring concentrations in portal venous effluent. Collecting the total luminal effluent and subtracting the known inflow volume was used to measure the net influx of water into the intestinal lumen. Results showed significantly increased accumulation of hypoxanthine in the small bowel segments with SCS alone. ATP, creatine phosphate and total adenine nucleotide content were significantly higher in the group undergoing luminal gas oxygenation versus SCS alone and resembled values from rat intestine *in vivo*. However, intestinal carbohydrate absorption was found to be severely impaired in both static cold-stored and gas oxygenated jejunal segments, even though gas oxygenation significantly improved post-ischemic absorption when compared to SCS. The net secretion of water into the gut lumen was significantly lower following gas oxygenation than SCS, reflecting less damage to intestinal villi. The authors noted that luminal gas oxygenation of the intestine could be improved by the introduction of supplements to the cold preservation solution, such as glutamine, an important substrate for intestinal mucosal cells. Although unique opportunities exist for the preservation of the small intestine using intraluminal gas oxygenation (a variant to intravascular PSF), this area of research has remained largely unexplored.

In contrast to small bowel intraluminal gas oxygenation, pancreas PSF has started to attract more interest in recent years. Currently, it is widely regarded that improvements in organ preservation may have a positive impact on pancreatic islet isolation and transplant outcomes [33]. For some time, the two-layer method (TLM) was considered the state-of-the-art for pancreas preservation before islet isolation. This has recently been challenged by studies showing that islet isolation outcomes are equivalent when comparing TLM and conventional SCS [1,7,78]. It is likely that the inefficiency of oxygen delivery by passive diffusion from the organ surface alone is responsible for the limited efficacy of TLM in preserving larger organs [63].

Over the last several years, PSF has been identified as a possible improvement to the current pancreas preservation protocol, particularly before islet isolation. Our research group is currently studying PSF of the pancreas to parallel our concurrent interests in pancreas HMP [89,91] and have recently published several works on A-PSF of porcine pancreata for the purposes of improving whole organ and islet quality [78,79]. In one study [79], human and porcine pancreata were preserved using TLM or A-PSF at 4 °C. A-PSF was performed via the superior mesenteric artery and either the splenic artery (human) or the celiac trunk (pig) using a custom-designed, portable electrochemical oxygen concentrator (Giner Inc., Newton, MA). Following procurement, the organs were imaged by conventional MRI and ATP levels and ATP-to-inorganic phosphate ratios were estimated using <sup>31</sup>P-NMR spectroscopy. MRI revealed well-distributed areas of negative contrast throughout all persufflated pancreata, indicating the homogeneous presence of gas within the organ. Rat pancreata preserved by TLM showed relatively

high ATP levels, though ATP levels were nearly undetectable in porcine pancreata preserved with TLM. In contrast, human pancreata preserved by A-PSF exhibited ATP-to-inorganic phosphate ratios similar to those observed in the rat pancreata on the TLM. Additionally, when A-PSF was stopped, ATP-to-inorganic phosphate ratios quickly declined to undetectable levels, similar to porcine organs preserved by TLM. When A-PSF was restarted, ATP levels rose again. In another study, DCD porcine pancreata were procured and the splenic lobe was separated from the connecting and duodenal lobes [78] – the anatomy being described previously [12]. The duodenal lobe was isolated following 1.5–2 hours of SCS and served as a first control, while the connecting lobe was stored on TLM for 24 hours and at 4 °C to serve as a second control. Splenic lobes were submerged in cold preservation solution and preserved by A-PSF via the celiac trunk and superior mesenteric artery for 24 hours and at 4 °C. Biopsies from organs preserved by A-PSF showed distended capillaries and less autolysis and necrosis when compared to organs preserved by TLM. In contrast, TLM-stored pancreata showed frequent pyknotic nuclei, indicating possible irreversible cellular damage. A follow-up study extended the comparison to porcine pancreatic isolation, having shown that 24 hours of A-PSF was better than the TLM in preserving islet morphology, viability and post-culture recovery (unpublished results). Collectively, these results illustrate the potential of A-PSF in improving tissue and islet quality in larger pancreata when compared with conventional preservation methods.

These early and promising results have established the need for more extensive studies since pancreas PSF represents a significant opportunity to improve both solid organ and

islet preservation over the current preservation techniques used in the field. Additionally, the portable electrochemical oxygen concentrator used in our studies may enable more widespread use of PSF, not just of the pancreas, since it provides a safe method of delivering gas (or gas mixtures) during transportation and especially during air travel. **Table 1.5** summarizes the published work on small intestine and pancreas PSF presented in this review.

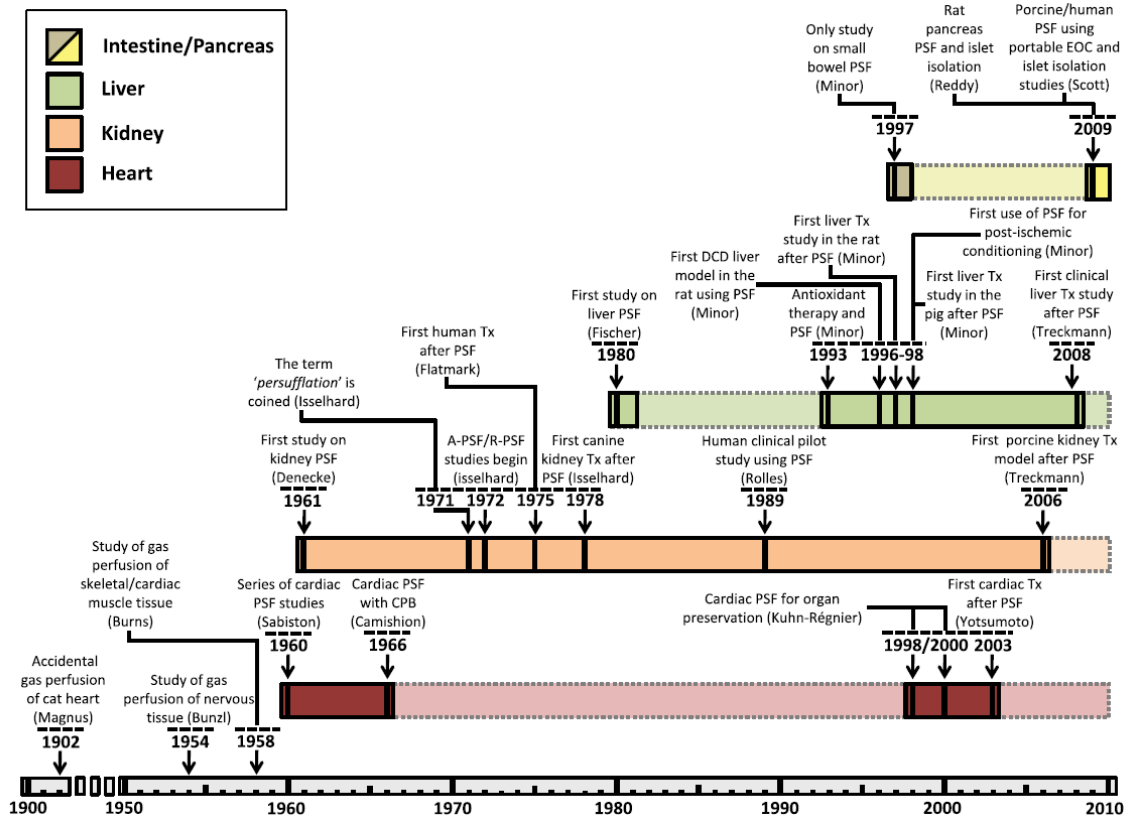
A schematic of the key milestone events during the historical development and use of PSF is presented in **Figure 1.4**. Comparison between anterograde and retrograde persufflation

Year	Author [Ref.]	Model	Approach	WIT (min)	Duration of PSF (h)	Gas used	Temp (°C)	Primary endpoint
<i>Small intestine</i>								
1997	Minor T [51]	Rat	Luminal	NS	18	O <sub>2</sub>	4	Intestinal function and metabolic profile after PSF
<i>Pancreas</i>								
2010	Scott WE III [79]	Pig (DCD)	A-PSF	<30	<24	40% O <sub>2</sub>	4	Metabolic quality during PSF, comparison with TLM
2010	Scott WE III [78]	Pig (DCD)	A-PSF	<30	24	40% O <sub>2</sub>	4	Histologic assessment after PSF, comparison with TLM

DCD, donation after cardiac death; NS, not specified; TLM, two-layer method.

**Table 1.5:**

Summary of published work on small intestine and pancreas PSF.



**Figure 1.4:**

Historical timeline of significant contributions to the development of persufflation as a method of tissue and organ preservation.

Earlier, we outlined that 2 main modes of PSF have been introduced and evaluated as a means of delivering oxygen to an organ. The relative merits of R-PSF versus A-PSF were not clearly established by earlier studies and it was not until the early 1970's that studies were undertaken to directly compare the 2 methods in a single system (canine kidney) [28,29,32]. Isselhard et al. developed an in situ ischemia model to study the effects of SCS, A-PSF or R-PSF on canine kidney preservation. Initially, they claimed that adequate preservation of kidneys required oxygen gas pressures of at least 60 mm Hg for

A-PSF and 30–60 mm Hg for R-PSF. Because the authors did not present data at lower PSF pressures, it is unclear what criteria were used to determine adequate oxygenation – whether it was visual detection of gas escaping the renal vein or puncture holes in the capsule, or whether it was based on measured ATP. Nevertheless, they showed that an increase from 60 to 100 mm Hg in A-PSF did not improve ATP levels. The investigators did not comment on whether these pressures were sufficient to maintain ATP levels at control levels. On the other hand, the metabolic profile improved with an increase from 30 to 60 mm Hg in R-PSF. After 8 hours of R-PSF at 60 mm Hg, the ATP levels were near that of healthy controls. When directly comparing A-PSF at 60 mm Hg and R-PSF at 30 mm Hg, the authors illustrated that ATP levels were maintained at similar levels and at similar points during cold preservation.

Subsequently, this research group extended their comparison between A-PSF and R-PSF to the reperfusion period. They showed that A-PSF (at 90–100 mm Hg) for 4 hours resulted in deterioration of renal function upon reperfusion, despite being able to maintain adequate levels of ATP throughout preservation. These results were in contrast to those obtained for R-PSF (at 30 mm Hg); R-PSF for 4 hours with reperfusion exhibited no such deterioration in function and resulted in faster restoration of normal kidney function when compared with static cold-stored kidneys. Additionally, glomerular filtration rate and renal plasma flow dropped in most kidneys preserved by A-PSF, whereas they had normalized by the second day after reperfusion in kidneys preserved by R-PSF. The authors noted that systemic blood pressures immediately increased for both sets of animals following reperfusion, regardless of the preservation technique employed.



However, in animals having a kidney preserved by A-PSF, the systemic blood pressures increased abruptly – until they normalized again after 40–60 minutes. Dramatic blood pressure increases were not seen with kidneys preserved by either SCS or R-PSF. It was unclear how A-PSF would cause such disparate change in systemic blood pressure – yet these physiologic changes may be attributable to either vascular spasm following the mechanical stresses of surgical manipulation or PSF, reflexive responses of systemic vessels to decreased renal perfusion (via the renin–angiotensin system) or vascular damage and dysfunction with possible thrombosis. In further investigations, these researchers decided to use a A-PSF pressure of 90–100 mm Hg, even though it was determined that lower pressures would suffice. It is very possible that the elevated PSF pressures may have damaged the renal vasculature. Aside from mechanical damage, elevated oxygen levels throughout the glomerular capillary beds may have created a favorable setting for free radical damage. This may not be the case during R-PSF, where the resistances to gas flow are 2–3 times lower and the regional oxygen concentrations are lower (as gas circumvents capillary beds and exits capsular veins). The authors have cited that histologic evidence points to more noticeable changes in the glomerular structure during A-PSF than R-PSF, but these data were unpublished and thus inconclusive.

In contrast, Fischer et al. described that A-PSF may not cause functional damage to the vasculature of an organ during preservation [18]. They described a study in which porcine hearts were subjected to 16 minutes of WIT and stored for 3.3 hours at 0–1 °C by either SCS or coronary A-PSF and then orthotopically transplanted. It was shown that

nitric oxide production by coronary endothelium was not adversely affected by A-PSF (as compared with SCS) and the ability of the coronaries to dilate and contract was preserved during reperfusion. Notable differences between this study and past studies involving A-PSF were that A-PSF was performed on porcine hearts (rather than canine kidneys) and under lower PSF pressures (45 mm Hg). Clearly, differences between the organ models may have contributed to varying results using A-PSF.

Despite somewhat conflicting results between the experimental models, it is reasonably certain that optimizing the PSF technique for both perfusion pressures and oxygen concentrations is important in achieving the best preservation possible. It is also likely that the optimal PSF technique may be different for different organs. It may be that A-PSF under lower pressures and lower oxygen tension could yield comparable, if not better, outcomes than R-PSF. However, this scenario has remained largely unstudied. In the case of the kidney and liver, it appears that the Cologne group may have maximized success using R-PSF, but it seems A-PSF has not been fully optimized and may prove to be the better approach for certain organs or applications.

In a very recent review, Fischer recommends that the coronary oxygen PSF should be carried out by A-PSF via the coronary arteries with outflow of gas from the coronary sinus. Retrograde gas flow through the aorta to reach coronary arteries does not establish a retrograde PSF of the myocardium. In contrast, Fischer argues that PSF in organs like liver and kidney should not be established in an anterograde manner because entry of gas into the microvessels may block any reperfusion. Hence, R-PSF is recommended in these

organs because gas never reaches the microvessels and leaves the organ via openings in capsular veins [16]. **Table 1.6** summarizes some of the potential advantages and disadvantages with A-PSF and R-PSF.

Preservation technique	Advantages	Disadvantages
Anterograde persufflation (A-PSF)	Follows physiologic flow path May directly deliver gas to a greater part of the organ	Elevated driving pressures may damage vascular function or endothelium May cause spastic or reflexive vascular changes, reducing blood flow to kidney and increasing systemic blood pressure May damage renal microvasculature and has resulted in poorer transplant outcomes
Retrograde persufflation (R-PSF)	Has been shown to sufficiently oxygenate and preserve various organs  May require lower driving pressures	Flow is in the opposite direction of physiological flow and highest pressures localized to thin-walled veins May require small punctures on surface of organ which could lead to bleeding upon reperfusion May not fully deliver oxygen-rich gas to all regions of the organ

**Table 1.6:**

Potential advantages and disadvantages of A-PSF and R-PSF.

## **Comparison between hypothermic machine perfusion and persufflation**

HMP is a method of organ preservation that has recently seen a resurgence of interest and shown clinically to have significant benefits over conventional SCS of kidneys [60,90,95]. Kidneys preserved using HMP have shown better early graft function when compared with SCS [44,61]. HMP has recently been recommended as the preferred preservation method for DCD and extended criteria donor kidneys [60,85,90,95,100]. Recently, data is emerging for clinical use of HMP in other organs. Guarrera et al. have shown excellent outcomes, including decreased length of hospital stay with the first human trial of HMP-preserved livers [23]. The scientific basis behind HMP is largely based on rapidly reducing and maintaining the core organ temperature during ischemia. The potential for delivering nutrients, removing harmful waste products, extending cold preservation times, maintaining a patent vascular bed and being able to prospectively monitor whole organ viability during preservation, are all potential benefits of HMP [90]. Potential disadvantages of HMP may include excessive damage to the vascular endothelium as a result of fluid shear and hydrostatic pressures, inadequate oxygen solubility of the perfusate, the possibility that vital or protective substrates of metabolism are continually removed via the circulation, the development of edema detrimental to the organ and the increased cost relative to SCS and possibly PSF. A summary of the advantages and disadvantages of SCS, HMP and PSF can be found in **Table 1.1**.

Very few studies have directly compared HMP and PSF, yet some work exists in this regard. Within the last 10 years, So and Fuller compared SCS, HMP, and R-PSF in the

preservation of rat livers [82]. The organs were harvested and divided into 3 groups, all of which were stored at 4 °C. Group 1 livers were preserved by SCS in non-oxygenated UW solution alone, Group 2 employed R-PSF with livers bathed in non-oxygenated UW solution, and Group 3 livers were preserved by HMP bathed in oxygenated UW solution. Tissue samples were obtained from livers at 2 and 24 hours of cold preservation and samples were analyzed for adenine nucleotide levels and glucose, lactate, ketone and alanine contents. At 2 hours, ATP levels were elevated in livers preserved by HMP and R-PSF, but were only statistically different from static cold-stored livers in the case of HMP. At 24 hours, the situation was different revealing that both HMP and R-PSF had the effect of significantly increasing ATP levels as compared with SCS. Lactate levels were initially elevated during SCS and R-PSF, but after 24 hours the lactate levels were comparable in livers preserved by HMP or R-PSF. Measured glucose contents were significantly higher during SCS and R-PSF than with HMP. Additionally, alanine levels were significantly elevated under R-PSF and ketone bodies were significantly lower with HMP at both time points. The authors concluded that both HMP and R-PSF could oxygenate a liver during long preservation times. Differences in early lactate measurements between the 2 groups were attributable to lactate being flushed out continuously during HMP. These are very relevant findings, because it may be that lactate is a beneficial substrate utilized by tissue during cold preservation. The authors noted that R-PSF did not appear to completely reverse the low ATP state of early ischemia as quickly as HMP, but these assertions are debatable. They believed that the metabolic resuscitation of organs following a period of hypoxia would require over 2 hours of PSF.

Along similar lines, Stegemann et al. recently published a study directly comparing the 3 modalities of cold preservation with DCD livers [83]. Following 30 minutes of WIT, rat livers were harvested and preserved for 18 hours using SCS, HMP or R-PSF. Organ viability was evaluated following in vitro reperfusion for 120 minutes with warm, oxygenated Krebs solution. Portal venous pressures were estimated during reperfusion and alanine aminotransferase, lactate/glutamate dehydrogenase levels were measured in the effluent. The degree of lipid peroxidation, metabolic status and cellular morphology were also studied. Hepatocellular damage was found to be greater during reperfusion in HMP-preserved livers versus those preserved by R-PSF. Glutamate dehydrogenase, an enzyme normally found within mitochondria, was shown to be elevated only during HMP. Histologic analysis of tissue biopsies paralleled the enzyme leakage data. Evidence of lipid peroxidation was similar between HMP and R-PSF, while the metabolic status of persufflated livers was better – as evidenced by significantly higher ATP levels during reperfusion. Finally, only after HMP did the portal venous pressures rise during reperfusion. In contrast, bile production rose significantly only after R-PSF. These data suggest that R-PSF may be a superior method of cold preservation for DCD livers. Longer term recovery of function was not studied during these experiments, yet it begs the question what happens to the organs following 2 hours of reperfusion. A limitation of this study was the use of a reperfusate that was not blood and did not contain any of the proteins (including clotting factors) typically found in plasma. It must be emphasized that there are a number of variables directly affecting the oxygen delivery to tissue by either

HMP or PSF, including the fluid dynamic parameters, perfusate oxygen solubility and the patency of the intravascular flow path.

We reviewed earlier the most recent study by Treckmann et al., in which they compared SCS, HMP and R-PSF in porcine kidneys using an autotransplantation model [96]. Recipient survival at POD 7 was 100% after re-transplant of kidneys preserved by R-PSF, while only 57% by SCS and 60% by HMP. In animals re-transplanted with kidneys preserved by either SCS or HMP, plasma creatinine levels remained significantly elevated above baseline, whereas animals with persufflated kidneys maintained normal creatinine clearance. Significant proteinuria and increased lipid peroxidation was noted only after re-transplantation of HMP preserved kidneys. Microscopic evaluation of tissue from explanted organs revealed that only persufflated kidneys were indistinguishable from healthy controls, which was not the case for kidneys preserved by SCS or HMP. Mild interstitial nephritis characterized static cold-stored kidneys, while HMP-preserved kidneys exhibited tubular protein deposits with signs of interstitial inflammation. The authors acknowledged certain limitations of their study, including the use of UW solution as the HMP perfusate instead of the gold-standard, Belzer machine perfusion solution. Another limitation of this study, as noted by the authors, were the relatively short preservation (4 hours) and monitoring (7 days postoperatively) times, which are not representative of standard practice. Future research might consider repeating this study using an allotransplant model to provide additional information, as acute rejection episodes have been linked to delayed graft function [62, 65], which in turn has been shown to be influenced by ischemia time and the method of preservation [62, 90]. It is also noteworthy that only kidneys preserved by R-PSF received the antioxidant SOD,



whereas the other 2 groups did not. This difference may have contributed to differences between HMP and R-PSF. Nevertheless, the authors concluded that R-PSF enhanced organ viability and function following a period of WIT in procured kidneys.

It remains difficult to appreciate the true benefit of PSF over HMP (or vice versa), given the conflicting results amongst studies directly comparing the 2 techniques. What is clear is that the 2 modalities exhibit at least comparable potential, particularly with resuscitation of DCD kidneys and livers. Further studies are needed to better reveal the relative utility of each technique with regards to standard and expanded criteria organ preservation.

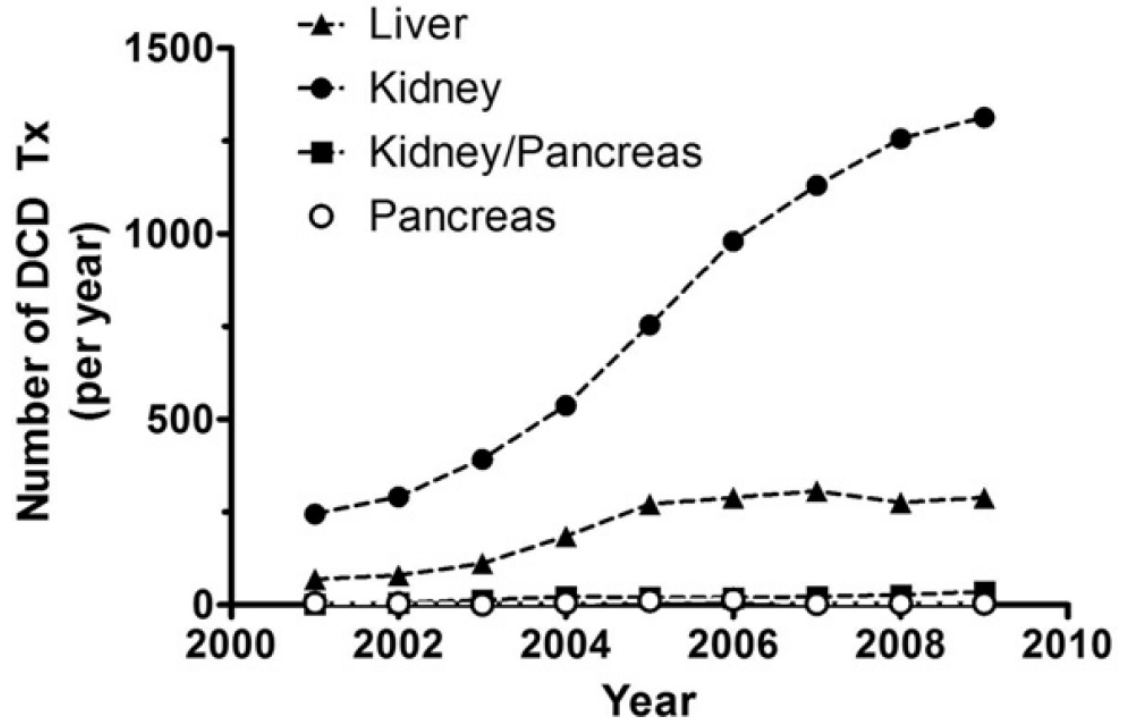
### **Prospective implications for persufflation in transplantation**

There is a clear longstanding discrepancy between the numbers of donor organs available for transplant and the numbers of prospective recipients on waiting lists. With the field of allotransplantation having come far over the last 60 years, an indisputable and persistent reality has been the shortage of donor organs. Many approaches have been levied in order to make more organs available for the donor pool, including the responsible expansion of acceptance criteria and improvements in organ preservation strategies. Some of these actions have yielded fruitful results and have helped prevent amplification of the problem. Data compiled by the United Network for Organ Sharing (UNOS) between 2001 and 2009 has illustrated both the promising and concerning trends (UNOS Data as of April 30th, 2010). Though the overall numbers of recipients on waiting lists have steadily decreased for heart, liver and simultaneous pancreas-kidney transplantation, the numbers of prospective kidney and pancreas transplant recipients have increased since

2001 by 38.9% and 22.3%, respectively. In the case of the kidney, the mean percent growth of the waitlist was 6.35% per year during this time span. In addition, most data indicate that the mean percent increase in the number of new patients added to a waitlist per year has increased during every year of this era, with the number of new kidney transplant candidates added at a mean rate of 5.2% annually (with a range of 0.2–11.0% per year). With kidney transplantation being the definitive treatment option for end-stage renal disease, it is no surprise that the candidate list is getting longer every year.

Due to this increased demand for transplantable organs, the number of DCD transplants has been steadily increasing for both kidney (3.1% per year) and liver (3.5% per year). **Figure 1.5** depicts the trends in DCD transplants for liver, kidney, pancreas and simultaneous pancreas-kidney. The stark increase in the numbers of DCD kidney transplants over the last 6 years results from the more wide-spread utilization of HMP during preservation, illustrating that continued acceptance of newer preservation strategies can be a successful approach to make more organs available for transplant. Despite these efforts, many more organs could still be retrieved. In 2009, for example, the total number of DCD transplants only amounted to 8.2% of all performed solid organ transplants. Of all organs recovered for DCD transplant since 2001, 30.1% of livers, 21.4% of kidneys and 50.4% of pancreata were never transplanted. According to UNOS records, 17.2% of livers, 3.9% of kidneys and 11.5% of DCD pancreata that had been procured were discarded due to WIT beyond what was considered acceptable. In addition, many more organs were classified under an ‘other’ category, which suggests

that some organs may have been discarded from consideration after having undergone unknown periods of WIT. Many of these consented organs could have been salvageable.

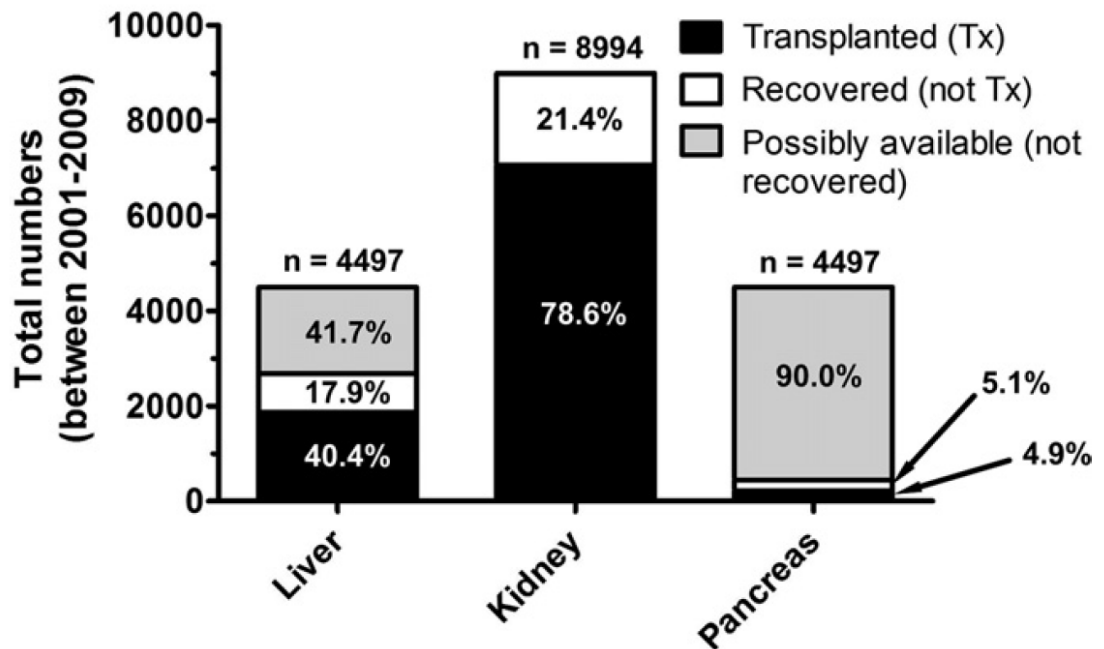


**Figure 1.5:**

Relative trends comparing number of donation after cardiac death (DCD) liver, kidney, simultaneous kidney/pancreas and pancreas transplants performed in the United States between 2001 and 2009. Data illustrates the increase in DCD liver and kidney transplants over the last six years, with the increase in the number of kidney transplants being due largely to improved preservation protocol, like hypothermic machine perfusion. Data was prepared by the United Network for Organ Sharing (UNOS) on April 30th, 2010.

It could be argued that the room for improvement is limited (based on these numbers alone). However, it is likely that many potential DCD organs are never procured because it is perceived that their poor quality does not merit the investment of resources required

for their recovery. It is conceivable that improved preservation techniques could result in a lengthening of allowable ischemic times (particularly for heart, liver and pancreas), possibly making previously unsuitable organs suitable for transplant. In other words, advancements in organ preservation may in fact accompany the expansion of donor organ criteria. The opportunity to resuscitate organs damaged by prolonged WIT and to better prevent their deterioration during storage should provide sufficient impetus to pursue the development of promising preservation strategies – like PSF. **Figure 1.6** illustrates the total DCD transplants been performed between 2001 and 2009 and further segregates them into the transplanted, recovered (but not transplanted) and possibly available (but not recovered) fractions. The numbers of organs that are possibly available but are never recovered have been estimated by assuming that each DCD kidney donor exhibits the potential to donate a liver and pancreas.



**Figure 1.6:**

Total numbers of donation after cardiac death (DCD) transplants performed in the United States between 2001 and 2009, further segregated into transplanted and recovered (but not transplanted) fractions. Additionally, DCD donor livers and pancreata are often not recovered with DCD donor kidneys due to their true or perceived poor quality; these organs (represented by gray bars) are possibly available for recovery and transplant, and may represent target organs for resuscitation via PSF. Data was prepared by the United Network for Organ Sharing (UNOS) on April 30th, 2010.

Even if improvements in preservation strategy do not lead to an immediate improvement in the number of transplantable organs, an incremental improvement in this area should be welcomed. Ultimately, the number of patients that die while waiting on transplant lists is the most important statistic. For instance, on an annual basis, 6.4% and 10.4% of potential transplant candidates for kidney and liver, respectively, do not survive long

enough to make it to the operating room. Despite the recent strides made by the field of transplantation, many patients still never receive an opportunity to accept a potentially life-saving organ. In this light, seeking better ways to recover and preserve a greater number of suitable organs should continue to be a primary objective.

PSF has the potential to lengthen the allowable WIT and cold ischemia time for any organ, as supported by some of the studies reviewed herein. As described earlier in this section, there remains a unique opportunity to maximize the number of accepted DCD donors by rescuing these organs from incurring intolerable amounts of ischemic damage. The case has been made that PSF may benefit heart, liver, kidney and pancreas transplant. A potential application that was only briefly discussed in this review is pancreas PSF before islet isolation. In addition to the unique susceptibility of the pancreas and the islets of Langerhans to ischemia [9, 11, 39, 80], islet cell transplantation poses additional challenges that are not seen in solid organ transplant. For instance, due to the complexity and expense associated with islet isolation, very few centers have the capacity to produce therapeutic preparations. Consequently, procured pancreata may need to be transported further in order to be processed for their islets. These additional travel considerations and distances may require longer preservation times (>8–10 hours). Studies performed at our institution have shown how pancreas PSF could be used to preserve human islets [78, 79]. Given the therapeutic promise of clinical islet cell transplantation [4, 13, 20, 25, 26, 72–74, 81, 98], exploring the utility of pancreas PSF is one of many efforts that are worthwhile.

To expand the acceptance and utilization of PSF in organ preservation, the technique must be developed further. Future work in PSF will involve: (1) optimization of technique and/or operational parameters so they are tailored to the tissue/organ-of-interest; (2) exploration of its use in conjunction with other preservation techniques (such as with HMP); or (3) as a method to condition organs prior to reperfusion; (4) direct comparison with other well-accepted preservation techniques; (5) development of portable PSF systems (like the electrochemical oxygen concentrator); (6) the identification of single or multiple pharmacologic agents used to prevent or reduce oxygenation and/or reperfusion injury; and (7) persuasion of the clinical community that *ex vivo* PSF is not the same as *in vivo* gas embolization – the two are fundamentally different from each other and (if performed properly) PSF should not cause embolization. **Table 1.7** summarizes some of the keys areas of future work that may accompany an advancement of PSF.

<p>Optimization of technique for specific tissue or organ, including</p> <ul style="list-style-type: none"> <li>• Development of surgical procurement protocol(s)</li> <li>• Identification of appropriate approach (A-PSF, R-PSF or other)</li> <li>• Minimization of required pressures</li> <li>• Identification of appropriate gas or gas mixture (i.e., pO<sub>2</sub>)</li> </ul> <p>Direct comparisons between PSF and the state-of-the-art in preservation for a specific application</p> <p>Exploration of utility in non-traditional applications, such as</p> <ul style="list-style-type: none"> <li>• Combination of PSF with other preservation strategies</li> <li>• Use of PSF in post-ischemic conditioning</li> </ul> <p>Continued development of a portable oxygen generator for PSF</p> <p>Identification of appropriate strategy for the prevention of injury due to enhanced oxygenation during preservation or ischemia-reperfusion injury, including</p> <ul style="list-style-type: none"> <li>• Type of anti-oxidant(s), anti-apoptotic agent(s), or other drug(s)</li> <li>• Dose of treatment(s)</li> <li>• Schedule of treatment(s)</li> </ul> <p>Elucidation of differences between PSF and gas embolization, which will include efforts to</p> <ul style="list-style-type: none"> <li>• Demonstrate negligible presence of gas following reperfusion of persufflated organ</li> <li>• Maximize benefit to transplant community (e.g., extended allowable WIT and CIT)</li> <li>• Maximize benefit to recipient of persufflated organ (e.g., lowered risk of delayed graft function)</li> <li>• Establish that transplantation of persufflated organ carries limited risk of adverse clinical sequelae</li> </ul>
--

**Table 1.7:**

Areas of future work in PSF.



We have attempted to demonstrate by the work presented in this review that oxygen gas delivered by PSF was found to be useable by a number of different types of tissues during hypothermic preservation. Hypothermic PSF has been shown to be capable of extending the allowable WIT and cold ischemia time and to be better in maintaining organ quality when compared with SCS and possibly HMP. The basis behind the intervention of PSF is to provide an adequate oxygen supply to an organ during preservation. Data collected over decades has confirmed that improved oxygenation is better for maintaining the quality of an organ and, in some cases, enables the recovery and resuscitation of reversibly-damaged tissue. Most of the studies presented in this review have demonstrated that PSF exhibits the capacity to improve the metabolic quality of tissue, as measured using a number of methods and in a variety of organs, and is poised for more research and clinical application.

## References:

1. A. Agrawal, K. Gurusamy, S. Powis, D.W. Gray, B. Fuller, B.R. Davidson, A metaanalysis of the impact of the two-layer method of preservation on human pancreatic islet transplantation, *Cell Transplant.* 17 (2008) 1315–1322.
2. A. Agrawal, P.W. So, A. Penman, S. Powis, B. Davidson, M. Press, B. Fuller, Limited penetration of perfluorocarbon in porcine pancreas preserved by two-layer method with (19)fluorine magnetic resonance spectroscopy and headspace gas chromatography, *Cell Transplant.* 19 (2010) 1021–1029.
3. C.N. Barnard, The operation. A human cardiac transplant: an interim report of a successful operation performed at Groote Schuur Hospital, Cape Town, *S. Afr. Med. J.* 41 (1967) 1271–1274.
4. M.D. Bellin, R. Kandaswamy, J. Parkey, H.J. Zhang, B. Liu, S.H. Ihm, J.D. Ansite, J. Witson, P. Bansal-Pakala, A.N. Balamurugan, K.K. Papas, D.E. Sutherland, A. Moran, B.J. Hering, Prolonged insulin independence after islet allotransplants in recipients with type 1 diabetes, *Am. J. Transplant.* 8 (2008) 2463–2470.
5. A. Bunzl, A.S. Burgen, B.D. Burns, N. Pedley, K.G. Terroux, Methods for studying the reflex activity of the frog's spinal cord, *Br J Pharmacol Chemother* 9 (1954) 229–235.
6. B.D. Burns, J.G. Robson, G.K. Smith, The survival of mammalian tissues perfused with intravascular gas mixtures of oxygen and carbon dioxide, *Can J Biochem Physiol* 36 (1958) 499–504.
7. J. Caballero-Corbalan, T. Eich, T. Lundgren, A. Foss, M. Felldin, R. Kallen, K. Salmela, A. Tibell, G. Tufveson, O. Korsgren, D. Brandhorst, No beneficial effect of two-layer storage compared with UW-storage on human islet isolation and transplantation, *Transplantation* 84 (2007) 864–869.
8. R.C. Camishion, A.L. Davies, K. Tokunaga, R.W. Solit, Retrograde perfusion of the coronary arteries with gaseous oxygen cardiopulmonary bypass, *Surgery* 59 (1966) 145–154.
9. P.O. Carlsson, A. Kiuru, A. Nordin, R. Olsson, J.M. Lin, P. Bergsten, L. Hillered, A. Andersson, L. Jansson, Microdialysis measurements demonstrate a shift to nonoxidative glucose metabolism in rat pancreatic islets transplanted beneath the renal capsule, *Surgery* 132 (2002) 487–494.
10. H. Denecke, Recovery of the kidney from aerobic and anaerobic ischemia in deep hypothermia, *Eur. Surg. Res.* 3 (1971).
11. K.E. Dionne, C.K. Colton, M.L. Yarmush, Effect of hypoxia on insulin secretion by isolated rat and canine islets of Langerhans, *Diabetes* 42 (1993) 12–21.
12. J. Ferrer, W.E. Scott 3rd, B.P. Weegman, T.M. Suszynski, D.E. Sutherland, B.J. Hering, K.K. Papas, Pig pancreas anatomy: implications for pancreas procurement, preservation, and islet isolation, *Transplantation* 86 (2008) 1503–1510.
13. P. Fiorina, A. Secchi, Pancreatic islet cell transplant for treatment of diabetes, *Endocrinol. Metab. Clin. North Am.* 36 (2007) 999–1013. ix.
14. J. Fischer, C. Funcke, S. Jeschkeit-Schubbert, G. Yotsumoto, F. Kuhn-Regnier, Coronary endothelial function in heart grafts of non-heart-beating donors (NHBD) after 3 hours hypothermic COP-preservation and orthotopic transplantation in pigs, *Eur. Surg. Res.* 33 (2001) 130–131.

15. J.H. Fischer, Hypothermic liver preservation using different flush solutions and retrograde oxygen persufflation technique, *Eur. Surg. Res.* 12 (1980) 19–20.
16. J.H. Fischer, Methods of Cardiac Oxygen Persufflation, in: K. Uygun, C.Y. Lee (Eds.), *Organ Preservation and Reengineering*, Artech House Publisher, Boston, 2011, pp. 105–126.
17. J.H. Fischer, A. Czerniak, U. Hauer, W. Isselhard, A new simple method for optimal storage of ischemically damaged kidneys, *Transplantation* 25 (1978) 43–49.
18. J.H. Fischer, C. Funcke, G. Yotsumoto, S. Jeschkeit-Schubbert, F. Kuhn-Regnier, Maintenance of physiological coronary endothelial function after 3.3 hours of hypothermic oxygen persufflation preservation and orthotopic transplantation of non-heart-beating donor hearts, *Eur. J. Cardiothorac. Surg.* 25 (2004) 98–104.
19. A. Flatmark, O. Slaattelid, G. Woxholt, Gaseous persufflation during machine perfusion of human kidneys before transplantation, *Eur. Surg. Res.* 7 (1975) 83–90.
20. T. Froud, C. Ricordi, D.A. Baidal, M.M. Hafiz, G. Ponte, P. Cure, A. Pileggi, R. Poggioli, H. Ichii, A. Khan, J.V. Ferreira, A. Pugliese, V.V. Esquenazi, N.S. Kenyon, R. Alejandro, Islet transplantation in type 1 diabetes mellitus using cultured islets and steroid-free immunosuppression: Miami experience, *Am. J. Transplant.* 5 (2005) 2037–2046.
21. L.P. Gabel, I. Bihler, P.E. Dresel, Contractility, metabolism and pharmacological reactions of isolated gas-perfused cat hearts, *Circ. Res.* 19 (1966) 891–902.
22. V.L. Gott, J.L. Gonzalez, M.N. Zuhdi, R.L. Varco, C.W. Lillehei, Retrograde perfusion of the coronary sinus for direct vision aortic surgery, *Surg. Gynecol. Obstet.* 104 (1957) 319–328.
23. J.V. Guarrera, S.D. Henry, B. Samstein, R. Odeh-Ramadan, M. Kinkhabwala, M.J. Goldstein, L.E. Ratner, J.F. Renz, H.T. Lee, R.S. Brown Jr., J.C. Emond, Hypothermic machine preservation in human liver transplantation: the first clinical series, *Am. J. Transplant.* 10 (2010) 372–381.
24. J.H. Harrison, J.P. Merrill, J.E. Murray, Renal homotransplantation in identical twins, *Surg. Forum* 6 (1956) 432–436.
25. B.J. Hering, R. Kandaswamy, J.D. Ansite, P.M. Eckman, M. Nakano, T. Sawada, I. Matsumoto, S.H. Ihm, H.J. Zhang, J. Parkey, D.W. Hunter, D.E. Sutherland, Single-donor, marginal-dose islet transplantation in patients with type 1 diabetes, *JAMA* 293 (2005) 830–835.
26. B.J. Hering, M. Wijkstrom, M.L. Graham, M. Hardstedt, T.C. Aasheim, T. Jie, J.D. Ansite, M. Nakano, J. Cheng, W. Li, K. Moran, U. Christians, C. Finnegan, C.D. Mills, D.E. Sutherland, P. Bansal-Pakala, M.P. Murtaugh, N. Kirchhof, H.J. Schuurman, Prolonged diabetes reversal after intraportal xenotransplantation of wild-type porcine islets in immunosuppressed nonhuman primates, *Nat. Med.* 12 (2006) 301–303.
27. W. Isselhard, Efficiency of retrograde oxygen persufflation in prolonged kidney preservation, *Eur. Surg. Res.* 10 (1978) 19–20.
28. W. Isselhard, M. Berger, H. Denecke, J. Witte, J.H. Fischer, H. Molzberger, Metabolism of canine kidneys in anaerobic ischemia and in aerobic ischemia by persufflation with gaseous oxygen, *Pflugers Arch.* 337 (1972) 87–106.
29. W. Isselhard, H. Denecke, W. Stelter, M. Berger, D. Sachweh, J. Witte, J.H. Fischer, Function and metabolism of canine kidneys after aerobic ischemia by orthograde persufflation with gaseous oxygen, *Res. Exp. Med. (Berl.)* 159 (1973) 288–297.

30. W. Isselhard, H. Denecke, J. Witte, M. Berger, J.H. Fischer, Renal function after hypothermic kidney ischemia with orthograde and retrograde O<sub>2</sub> - persufflation in situ, *Res. Exp. Med. (Berl.)* 157 (1972) 231–234.
31. W. Isselhard, J. Witte, H. Denecke, M. Berger, J.H. Fischer, Kidney function following hypothermic aerobic ischemia in situ, *Pflugers Arch.* 332 (Suppl. 332) (1972) R26.
32. W. Isselhard, J. Witte, H. Denecke, M. Berger, J.H. Fischer, H. Molzberger, Function and metabolism of canine kidneys after aerobic ischemia by retrograde persufflation with gaseous oxygen, *Res. Exp. Med. (Berl.)* 164 (1974) 35–44.
33. Y. Iwanaga, D.E. Sutherland, J.V. Harmon, K.K. Papas, Pancreas preservation for pancreas and islet transplantation, *Curr Opin Organ Transplant* 13 (2008) 445–451.
34. F. Kuhn-Regnier, W. Bloch, I. Tsimpoulis, M. Reismann, O. Dagktekin, S. Jeschkeit-Schubbert, C. Funcke, J.W. Fries, K. Addicks, E.R. de Vivie, J.H. Fischer, Coronary oxygen persufflation for heart preservation in pigs: analyses of endothelium and myocytes, *Transplantation* 77 (2004) 28–35.
35. F. Kuhn-Regnier, J.H. Fischer, S. Jeschkeit, Coronary oxygen persufflation for long-term myocardial protection, *Thorac. Cardiovasc. Surg.* 46 (Suppl. 2) (1998) 308–312.
36. F. Kuhn-Regnier, J.H. Fischer, S. Jeschkeit, R. Switkowski, O. Bardakcioglu, R. Sobottke, E.R. de Vivie, Coronary oxygen persufflation combined with HTK cardioplegia prolongs the preservation time in heart transplantation, *Eur. J. Cardiothorac. Surg.* 17 (2000) 71–76.
37. G.A. Laine, S.J. Allen, Left ventricular myocardial edema. Lymph flow, interstitial fibrosis, and cardiac function, *Circ. Res.* 68 (1991) 1713–1721.
38. H. Lauschke, M. Kotting, S. Akbar, T. Minor, Use of taurine as antioxidant in resuscitating livers from non-heart-beating donors by gaseous oxygen persufflation, *J. Invest. Surg.* 16 (2003) 7–11.
39. D.A. Lepore, T.A. Shinkel, N. Fasicaro, T.B. Mysore, L.E. Johnson, A.J. d'Apice, P.J. Cowan, Enhanced expression of glutathione peroxidase protects islet beta cells from hypoxia-reoxygenation, *Xenotransplantation* 11 (2004) 53–59.
40. W. Lochner, G. Arnold, E.R. Muller-Ruchholtz, Metabolism of the artificially arrested heart and of the gas-perfused heart, *Am. J. Cardiol.* 22 (1968) 299–311.
41. B. Luer, M. Koetting, P. Efferz, T. Minor, Role of oxygen during hypothermic machine perfusion preservation of the liver, *Transpl. Int.* 23 (2010) 944–950.
42. R. Magnus, Die Thätigkeit des überlebenden Säugethierherzens bei Durchströmung mit Gasen, *Arch Exp Path Pharmacol* 47 (1902) 200–208.
43. C. Massimo, L. Boffi, L. Pozzi, Sinusal standstill with ventricular automatism during retrograde perfusion of the coronary sinus under hypothermia for direct surgical approach to the aortic valves: an experimental study, *J. Thorac. Surg.* 36 (1958) 227–229.
44. L. Matsuoka, T. Shah, S. Aswad, S. Bunnapradist, Y. Cho, R.G. Mendez, R. Mendez, R. Selby, Pulsatile perfusion reduces the incidence of delayed graft function in expanded criteria donor kidney transplantation, *Am. J. Transplant.* 6 (2006) 1473–1478.
45. J.P. Merrill, J.E. Murray, J.H. Harrison, W.R. Guild, Successful homotransplantation of the human kidney between identical twins, *J. Am. Med. Assoc.* 160 (1956) 277–282.
46. T. Minor, W. Isselhard, Venous oxygen insufflation to prevent reoxygenation injury after ischemia of a solid organ, *Transplantation* 58 (1994) 121–123.

47. T. Minor, W. Isselhard, Synthesis of high energy phosphates during cold ischemic rat liver preservation with gaseous oxygen insufflation, *Transplantation* 61 (1996) 20–22.
48. T. Minor, W. Isselhard, H. Klauke, Reduction in nonparenchymal cell injury and vascular endothelial dysfunction after cold preservation of the liver by gaseous oxygen, *Transpl. Int.* 9 (Suppl. 1) (1996) S425–S428.
49. T. Minor, W. Isselhard, Y. Yamamoto, M. Obara, S. Saad, The effects of allopurinol and SOD on lipid peroxidation and energy metabolism in the liver after ischemia in an aerobic/anaerobic persufflation, *Surg. Today* 23 (1993) 728–732.
50. T. Minor, H. Klauke, W. Isselhard, Resuscitation of cadaveric livers from nonheart-beating donors after warm ischemic insult: a novel technique tested in the rat, *Experientia* 52 (1996) 661–664.
51. T. Minor, H. Klauke, W. Isselhard, Improved preservation of the small bowel by luminal gas oxygenation: energetic status during ischemia and functional integrity upon reperfusion, *Transplant. Proc.* 29 (1997) 2994–2996.
52. T. Minor, H. Klauke, M. Nagelschmidt, W. Isselhard, Reduction of proteolysis by venous-systemic oxygen persufflation during rat liver preservation and improved functional outcome after transplantation, *Transplantation* 63 (1997) 365–368.
53. T. Minor, H. Klauke, B. Vollmar, W. Isselhard, M.D. Menger, Biophysical aspects of liver aeration by vascular persufflation with gaseous oxygen, *Transplantation* 63 (1997) 1843–1846.
54. T. Minor, H. Klauke, B. Vollmar, M.D. Menger, W. Isselhard, Rat liver transplantation after long-term preservation by venous systemic oxygen persufflation, *Transplant. Proc.* 29 (1997) 410–411.
55. T. Minor, S. Saad, M. Kotting, M. Nagelschmidt, W. Isselhard, Short-term restoration by gaseous oxygen for long-term preservation of predamaged livers from non-heart-beating donors, *Transplant. Proc.* 29 (1997) 3474–3475.
56. T. Minor, S. Saad, M. Kotting, M. Nagelschmidt, A. Paul, Endischemic oxygen persufflation to improve viability of marginally preserved donor livers, *Transpl. Int.* 11 (Suppl. 1) (1998) S400–S403.
57. T. Minor, S. Saad, M. Nagelschmidt, M. Kotting, Z. Fu, A. Paul, W. Isselhard, Successful transplantation of porcine livers after warm ischemic insult in situ and cold preservation including postconditioning with gaseous oxygen, *Transplantation* 65 (1998) 1262–1264.
58. T. Minor, J. Stegemann, A. Hirner, M. Koetting, Impaired autophagic clearance after cold preservation of fatty livers correlates with tissue necrosis upon reperfusion and is reversed by hypothermic reconditioning, *Liver Transpl* 15 (2009) 798–805.
59. T. Minor, B. Vollmar, H. Klauke, W. Isselhard, M.D. Menger, Gaseous oxygenation of the ischemic rat liver. The influence of driving pressure and oxygen concentration on tissue aeration, *Adv. Exp. Med. Biol.* 454 (1998) 91–94.
60. C. Moers, J.M. Smits, M.H. Maathuis, J. Treckmann, F. van Gelder, B.P. Napieralski, M. van Kasterop-Kutz, J.J. van der Heide, J.P. Squifflet, E. van Heurn, G.R. Kirste, A. Rahmel, H.G. Leuvenink, A. Paul, J. Pirenne, R.J. Ploeg, Machine perfusion or cold storage in deceased-donor kidney transplantation, *N. Engl. J. Med.* 360 (2009) 7–19.
61. M.L. Nicholson, S.A. Hosgood, M.S. Metcalfe, J.R. Waller, N.R. Brook, A comparison of renal preservation by cold storage and machine perfusion using a porcine autotransplant model, *Transplantation* 78 (2004) 333–337.

62. A.O. Ojo, R.A. Wolfe, P.J. Held, F.K. Port, R.L. Schmouder, Delayed graft function: risk factors and implications for renal allograft survival, *Transplantation* 63 (1997) 968–974.
63. K.K. Papas, B.J. Hering, L. Guenther, M.J. Rappel, C.K. Colton, E.S. Avgoustiniatos, Pancreas oxygenation is limited during preservation with the two-layer method, *Transplant. Proc.* 37 (2005) 3501–3504.
64. D.E. Pegg, J. Foreman, C.J. Hunt, M.P. Diaper, The mechanism of action of retrograde oxygen persufflation in renal preservation, *Transplantation* 48 (1989) 210–217.
65. N. Perico, D. Cattaneo, M.H. Sayegh, G. Remuzzi, Delayed graft function in kidney transplantation, *Lancet* 364 (2004) 1814–1827.
66. T. Piratvisuth, J.M. Tredger, K.A. Hayllar, R. Williams, Contribution of true cold and rewarming ischemia times to factors determining outcome after orthotopic liver transplantation, *Liver Transpl. Surg.* 1 (1995) 296–301.
67. K.P. Platz, A.R. Mueller, C. Schafer, S. Jahns, O. Guckelberger, P. Neuhaus, Influence of warm ischemia time on initial graft function in human liver transplantation, *Transplant. Proc.* 29 (1997) 3458–3459.
68. K. Rolles, J. Foreman, D.E. Pegg, Preservation of ischemically injured canine kidneys by retrograde oxygen persufflation, *Transplantation* 38 (1984) 102–106.
69. K. Rolles, J. Foreman, D.E. Pegg, A pilot clinical study of retrograde oxygen persufflation in renal preservation, *Transplantation* 48 (1989) 339–342.
70. H. Ross, M.L. Escott, Gaseous oxygen perfusion of the renal vessels as an adjunct in kidney preservation, *Transplantation* 28 (1979) 362–364.
71. H. Ross, M.L. Escott, Renal preservation with gaseous perfusion, *Transplantation* 33 (1982) 206–208.
72. E.A. Ryan, J.R. Lakey, B.W. Paty, S. Imes, G.S. Korbitt, N.M. Kneteman, D. Bigam, R.V. Rajotte, A.M. Shapiro, Successful islet transplantation: continued insulin reserve provides long-term glycemic control, *Diabetes* 51 (2002) 2148–2157.
73. E.A. Ryan, J.R. Lakey, R.V. Rajotte, G.S. Korbitt, T. Kin, S. Imes, A. Rabinovitch, J.F. Elliott, D. Bigam, N.M. Kneteman, G.L. Warnock, I. Larsen, A.M. Shapiro, Clinical outcomes and insulin secretion after islet transplantation with the Edmonton protocol, *Diabetes* 50 (2001) 710–719.
74. E.A. Ryan, B.W. Paty, P.A. Senior, D. Bigam, E. Alfadhli, N.M. Kneteman, J.R. Lakey, A.M. Shapiro, Five-year follow-up after clinical islet transplantation, *Diabetes* 54 (2005) 2060–2069.
75. S. Saad, T. Minor, M. Kotting, Z.X. Fu, U. Hagn, A. Paul, M. Nagelschmidt, Extension of ischemic tolerance of porcine livers by cold preservation including postconditioning with gaseous oxygen, *Transplantation* 71 (2001) 498–502.
76. D.C. Sabiston Jr., J.L. Talbert, L.H. Riley Jr., A. Blalock, Maintenance of the heart beat by perfusion of the coronary circulation with gaseous oxygen, *Ann. Surg.* 150 (1959) 361–370.
77. D. Sachweh, W. Isselhard, H. Dennecke, W.J. Stelter, M. Berger, H. Lauschke, W.F. Eigler, Short time kidney preservation by hypothermic oxygen persufflation, *Bull Soc Int Chir* 31 (1972) 258–263.
78. W.E. Scott III, T.D. O'Brien, J. Ferrer-Fabrega, E.S. Avgoustiniatos, B.P. Weegman, T. Anazawa, S. Matsumoto, V. Kirchner, M. Rizzari, M.P. Murtaugh, T.M. Suszynski, T.

- Aasheim, L.S. Kidder, B.E. Hammer, S.G. Stone, L.A. Tempelman, D.E. Sutherland, B.J. Hering, K.K. Papas, Persufflation improves pancreas preservation when compared with the two-layer method (TLM), *Transplant. Proc.* 42 (2010) 2016–2019.
79. W.E. Scott III, B.P. Weegman, J. Ferrer-Fabrega, S.A. Stein, T. Anazawa, V. Kirchner, M. Rizzari, J. Stone, S. Matsumoto, B.E. Hammer, A.N. Balamurugan, L.S. Kidder, T.M. Suszynski, E.S. Avgoustiniatos, S.G. Stone, L.A. Tempelman, D.E. Sutherland, B.J. Hering, K.K. Papas, Pancreas oxygen persufflation increases ATP levels as shown by nuclear magnetic resonance, *Transplant. Proc.* 42 (2010) 2011–2015.
80. N. Sekine, V. Cirulli, R. Regazzi, L.J. Brown, E. Gine, J. Tamarit-Rodriguez, M. Girotti, S. Marie, M.J. MacDonald, C.B. Wollheim, et al., Low lactate dehydrogenase and high mitochondrial glycerol phosphate dehydrogenase in pancreatic beta-cells. Potential role in nutrient sensing, *J. Biol. Chem.* 269 (1994) 4895–4902.
81. A.M. Shapiro, J.R. Lakey, E.A. Ryan, G.S. Korbitt, E. Toth, G.L. Warnock, N.M. Kneteman, R.V. Rajotte, Islet transplantation in seven patients with type 1 diabetes mellitus using a glucocorticoid-free immunosuppressive regimen, *N. Engl. J. Med.* 343 (2000) 230–238.
82. P.W. So, B.J. Fuller, A comparison of the metabolic effects of continuous hypothermic perfusion or oxygenated persufflation during hypothermic storage of rat liver, *Cryobiology* 43 (2001) 238–247.
83. J. Stegemann, A. Hirner, U. Rauen, T. Minor, Gaseous oxygen persufflation or oxygenated machine perfusion with Custodiol-N for long-term preservation of ischemic rat livers?, *Cryobiology* 58 (2009) 45–51
84. N.T. Stowe, M.O. Magnusson, K. Jojima, G.M. Chisolm, A.C. Novick, R.A. Straffon, Combined use of normobaric oxygen perfusion and simple cold storage for extended kidney preservation, *Transplant. Proc.* 18 (1986) 553–556.
85. R.J. Stratta, P.S. Moore, A.C. Farney, J. Rogers, E.L. Hartmann, A. Reeves-Daniel, M.D. Gautreaux, S.S. Iskandar, P.L. Adams, Influence of pulsatile perfusion preservation on outcomes in kidney transplantation from expanded criteria donors, *J. Am. Coll. Surg.* 204 (2007) 873–882 (discussion 882–4).
86. T.M. Suszynski, G.M. Wildey, E.J. Falde, G.W. Cline, K.S. Maynard, N. Ko, J. Sotiris, A. Naji, B.J. Hering, K.K. Papas, The ATP/DNA ratio is a better indicator of islet cell viability than the ADP/ATP ratio, *Transplant. Proc.* 40 (2008) 346–350.
87. J.L. Talbert, L.H. Riley Jr., D.C. Sabiston Jr., A. Blalock, Retrograde perfusion of the coronary sinus with gaseous oxygen, *Am. Surg.* 26 (1960) 189–192.
88. J.L. Talbert, L.H. Riley Jr., D.C. Sabiston Jr., A. Blalock, An evaluation of gaseous oxygen perfusion as a method for maintaining renal viability during periods of complete ischemia, *Surg. Gynecol. Obstet.* 112 (1961) 593–599.
89. M.J. Taylor, S. Baicu, E. Greene, A. Vazquez, J. Brassil, Islet isolation from juvenile porcine pancreas after 24-h hypothermic machine perfusion preservation, *Cell Transplant.* 19 (2010) 613–628.
90. M.J. Taylor, S.C. Baicu, Current state of hypothermic machine perfusion preservation of organs: the clinical perspective, *Cryobiology* 60 (2010) S20–S35.
91. M.J. Taylor, S.C. Baicu, Hypothermic perfusion of pancreas: emphasis on preservation prior to islet isolation, in: K. Uykun, C.Y. Lee (Eds.), *Organ Preservation and Reengineering*, Artech House Publisher, Boston, 2011, pp. 85–104.

92. G.P. Tolstykh, J.F. Gelineau, L.M. Maier, L. Bunegin, Novel portable hypothermic pulsatile perfusion preservation technology: improved viability and function of rodent and canine kidneys, *Ann Transplant* 15 (2010) 35–43.
93. E. Totsuka, U. Fung, K. Hakamada, M. Tanaka, K. Takahashi, M. Nakai, S. Morohashi, A. Nishimura, Y. Ishizawa, H. Ono, Y. Toyoki, S. Narumi, M. Sasaki, Analysis of clinical variables of donors and recipients with respect to shortterm graft outcome in human liver transplantation, *Transplant. Proc.* 36 (2004) 2215–2218.
94. J. Treckmann, T. Minor, S. Saad, A. Ozcelik, M. Malago, C.E. Broelsch, A. Paul, Retrograde oxygen persufflation preservation of human livers: a pilot study, *Liver Transpl.* 14 (2008) 358–364.
95. J. Treckmann, C. Moers, J.M. Smits, A. Gallinat, M.H. Maathuis, M. van Kasterop-Kutz, I. Jochmans, J.J. Homan van der Heide, J.P. Squifflet, E. van Heurn, G.R. Kirste, A. Rahmel, H.G. Leuvenink, J. Pirenne, R.J. Ploeg, A. Paul, Machine perfusion versus cold storage for preservation of kidneys from expanded criteria donors after brain death, *Transpl. Int.* 24 (2011) 548–554.
96. J. Treckmann, M. Nagelschmidt, T. Minor, F. Saner, S. Saad, A. Paul, Function and quality of kidneys after cold storage, machine perfusion, or retrograde oxygen persufflation: results from a porcine autotransplantation model, *Cryobiology* 59 (2009) 19–23.
97. J.W. Treckmann, A. Paul, S. Saad, J. Hoffmann, K.H. Waldmann, C.E. Broelsch, M. Nagelschmidt, Primary organ function of warm ischaemically damaged porcine kidneys after retrograde oxygen persufflation, *Nephrol. Dial. Transplant.* 21 (2006) 1803–1808.
98. N.A. Turgeon, J.G. Avila, J.A. Cano, J.J. Hutchinson, I.R. Badell, A.J. Page, A.B. Adams, M.H. Sears, P.H. Bowen, A.D. Kirk, T.C. Pearson, C.P. Larsen, Experience with a novel efalizumab-based immunosuppressive regimen to facilitate single donor islet cell transplantation, *Am. J. Transplant.* 10 (2010) 2082–2091.
99. B.P. Weegman, V.A. Kirchner, W.E. Scott III, E.S. Avgoustiniatos, T.M. Suszynski, J. Ferrer-Fabrega, M.D. Rizzari, L.S. Kidder, K. R., D.E. Sutherland, and K.K. Papas, Continuous real-time viability assessment of kidneys based on oxygen consumption, *Transplant. Proc.* 42 (2010) 2020–2023.
100. J. Wight, J. Chilcott, M. Holmes, N. Brewer, The clinical and cost-effectiveness of pulsatile machine perfusion versus cold storage of kidneys for transplantation retrieved from heart-beating and non-heart-beating donors, *Health Technol. Assess.* 7 (2003) 1–94.
101. M. Yin, M.H. Booster, G.J. van der Vusse, J.G. Maessen, W.A. Buurman, G. Kootstra, Retrograde oxygen persufflation in combination with UW solution enhances adenine nucleotide contents in ischemically damaged rat kidney during cold storage, *Transpl. Int.* 9 (1996) 396–402.
102. G. Yotsumoto, S. Jeschkeit-Schubbert, C. Funcke, F. Kuhn-Regnier, J.H. Fischer, Total recovery of heart grafts of non-heart-beating donors after 3 hours of hypothermic coronary oxygen persufflation preservation in an orthotopic pig transplantation model, *Transplantation* 75 (2003) 750–756



## **Cryopreservation:**

Cryopreservation, or preservation based on freezing and long term storage of tissues, has great potential as a tool for organ preservation. If possible it would allow for the long term storage and banking of organs allowing for better HLA typing and screening of cross matches enabling potentially improved transplantation outcomes [30, 47]. Historically, cryopreservation has been plagued with challenges typically resulting in tissue death. The main problem associated with cryopreservation is the formation of ice crystals and resulting in fractures in the tissue causing tissue and cell death. One of the main approaches investigated to prevent the nucleation of ice crystals involves extremely rapidly cooling organs down to prevent crystallization forming super-cooled liquids. This process can be aided by adding solutes known as vitrification solutions such as DMSO, which interfere with hydrogen bonding of the water reducing the rate at which the tissue must be cooled to prevent crystallization. To date however many of these vitrification solutions have proven toxic at their required doses and this has proven a challenge still under investigation [48].

Investigation of cryopreservation of the pancreas has been identified as a potential candidate for pancreas preservation and investigated since the 70's [47, 49-51]. Investigations into this seem to have focused on the preservation of fetal tissue first in the rat [49, 50] and then in the human targeting the use of tissue obtained from aborted fetuses as a source [47, 51]. It seems that at the end of the 80's work on pursuing cryopreservation of pancreata petered out. This is most likely due to problems with the technique, the relative success of traditional hypothermic storage as well as possibly societal issues with the use of fetuses as a source of tissue for research/transplantation.

Recently however, a study has emerged using cryopreservation as a means to replace traditional enzymatic digestion for islet isolation. The basis for this technique is to preferentially disrupt the exocrine pancreas by infusing water via the duct while preserving the islets with vitreous fluid delivered via the vasculature during freezing. Initial findings suggest that this may be able to deliver functional islets from a juvenile pig model. These findings are positive and warrant further investigation into this method as well as the impact that long term cryo-exposure may have on islets obtained from these pancreata.

## **Nuclear Magnetic Resonance**

### **Theory of NMR:**

The following section was summarized and adapted from several texts [52-54].

The use of nuclear magnetic resonance spectroscopy and imaging has been a very powerful tool available to scientists since its simultaneous discovery in 1946 by Bloch and Purcell. It was initially utilized for physics and chemistry but was significantly advanced in the 1970's with the development of Fourier transform-NMR by Ernst which allowed for greater signal to noise and thus shorter scan times and then 2-dimensional Fourier transform NMR Lauterbur and Mansfield as allowing the generation of 2-dimensional images for magnetic resonance imaging. Since these discoveries much effort has been put into the development of NMR as an imaging and spectroscopy tool for investigating biological systems. In order to utilize its potential however some of the

underlying physical principles on which NMR is based must first be understood. The following section is intended as a brief introduction to some of these principles.

NMR is based on an intrinsic property of the nuclei of some atoms called spin. Spin is a measure of the magnetic moment of a nucleus and comes in multiples of  $\frac{1}{2}$ . When a nucleus with a non-zero spin is placed in a magnetic field (B); it tends to respond by precessing around the field direction at a characteristic angular frequency ( $\omega$ ). This was named for Joseph Larmor who postulated this phenomenon in the late 1800's and is:

$$\nu = \omega/2\pi$$

The angular frequency for a given magnetic field is defined as:

$$\omega = \gamma B$$

Where  $\gamma$  is the nuclear gyromagnetic ratio defined as the ratio of the nuclear magnetic moment to its angular momentum. Some important Larmor Frequencies to know are:

$${}^1\text{H} : 42.58 \text{ MHz/T}$$

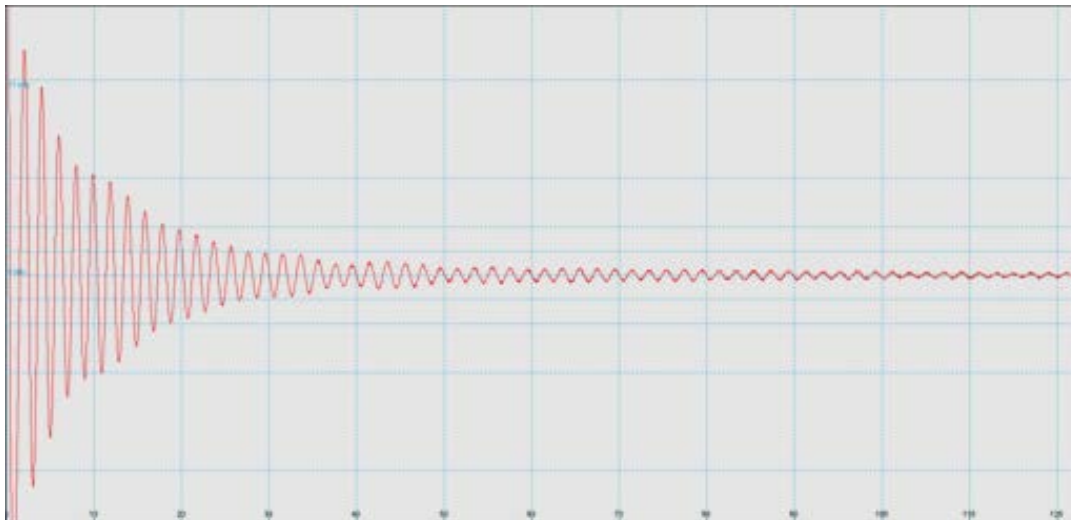
$${}^{35}\text{P} : 17.25 \text{ MHz/T}$$

$${}^{19}\text{F} : 40.08 \text{ MHz/T}$$

As the spin precesses around the magnetic field it can either be in a high or low energy configuration. The ratio of spins in the low energy state versus the high energy state is defined by the equation:

$$N^-/N^+ = e^{-E/kT}$$

Where  $E$  is the difference in energy between spin configurations,  $k$  is Boltzmann's constant and  $T$  is the temperature in Kelvin. If a photon of energy exactly matching the difference in these energy states comes along a spin can be switched from the low energy configuration to its high energy configuration. This can be done by irradiating the nuclei at the Larmor Frequency, typically utilizing a radiofrequency coil in practice, and this is known as nuclear magnetic resonance. When we take a step back and consider all of the atoms present in a sample of interest we must consider many spins at one time. To do this we add up all of the magnetic moments of a volume of interest and obtain the sample magnetization. If you were to simply place a sample into a magnetic field you would still get a magnetization of zero because while the spins are all at the same frequency, they are all precessing in random phase. When you pulse the nuclei with electromagnetic energy at the Larmor frequency you can flip the spins  $90^\circ$  from the magnetic field and make the spins phase coherent. When you do this you can now detect the sample by reading the voltage changes the sample generates due to Faraday's law of electromagnetic induction. This is typically done with a receiver coil, and is often referred to as a free induction decay or FID due to its shape as can be seen in **Figure 1.7**.



**Figure 1.7:**

Typical free induction decay (FID) acquired from the protons in a sample of water.

After you give your sample a  $90^\circ$  pulse the phase coherency and spin alignment tend to drift back towards their equilibrium state. The amount of time the sample takes to return to its equilibrium position in the direction of the magnetic field is characterized by the exponential function:

$$M_z = M_0 ( 1 - e^{-t/T_1} )$$

Where  $T_1$  is the amount of time it takes to reduce the difference in the longitudinal magnetization ( $M_z$ ) and the equilibrium magnetization ( $M_0$ ) by a factor of  $e$ . This is known as a samples'  $T_1$  and can range from hundreds of microseconds to over ten seconds. In addition to the 'relaxation' the sample exhibits toward the magnetic field following a  $90^\circ$  pulse, the phase coherency imparted by the pulse also tends to decay

back to its original random state. This process can also be described by an exponential function:

$$\mathbf{M}_{XY} = \mathbf{M}_{XY_0} e^{-t/T_2}$$

### **NMR Spectroscopy:**

An NMR spectrum is obtained by taking the Fourier transform of an FID. In the case of a simple molecule like water a single peak is observed when scanning at the proton resonant frequency. However when several different chemically bound forms of the nucleus of interest are present in a sample several peaks are obtained and their separation is due to the phenomenon known as chemical shift. When nuclei are placed into a constantly applied external magnetic field their electron clouds begin to circulate producing a tiny magnetic moment opposing this field. This usually reduces the effective magnetic field at the nucleus of interest by  $\sigma B_0$ :

$$\mathbf{B}_{\text{local}} = \mathbf{B}_0 (1 - \sigma)$$

where  $\sigma$  is the shielding constant for that particular nucleus. The shielding constant is proportional to the electron density surrounding the nucleus of interest. The electron density however, varies depending on how and what the nucleus of interest is bound to within a molecule. The differences observed can be seen in a spectrum as slight perturbations of the nuclei's resonant frequency separating the peaks in a field dependant

manner. If two molecules are chemically bound in the same way they are said to be equivalent. When looking at nuclei from a molecule slight alterations in the electron distribution due to the presence of other surrounding non-equivalent nuclei within 3 bond lengths may be spectroscopically observed. This is due to a property known as spin-spin coupling and causes a split in the signal centered on the nuclei's particular resonant frequency. This split is dependent on the spin state of the nucleus of interest and its neighbor and can be used to provide even more detailed chemical information about the molecular structure a nucleus is experiencing.

## References

1. World Health Organization: Diabetes Fact sheet N°312. In.: <http://www.who.int/mediacentre/factsheets/fs312/en/index.html>.
2. World Health Organization: Diabetes Programme. In.: <http://www.who.int/diabetes/en/>
3. Center for Disease Control: National Diabetes Fact Sheet, 2011. In.: [http://www.cdc.gov/diabetes/pubs/pdf/ndfs\\_2011.pdf](http://www.cdc.gov/diabetes/pubs/pdf/ndfs_2011.pdf).
4. American Diabetes Association: The Cost of Diabetes. In.: <http://www.diabetes.org/advocate/resources/cost-of-diabetes.html>.
5. Zhang P, Zhang X, Brown J, Vistisen D, Sicree R, Shaw J, et al. Global healthcare expenditure on diabetes for 2010 and 2030. *Diabetes Res Clin Pract* 2010;87(3):293-301.
6. Lakey JR, Burrige PW, Shapiro AM. Technical aspects of islet preparation and transplantation. *Transpl Int* 2003;16(9):613-632.
7. Ballinger WF, Lacey PE. Transplantation of intact pancreatic islets in rats. *Surgery* 1972;72(2):175-186.
8. Najarian JS, Sutherland DE, Baumgartner D, Burke B, Rynasiewicz JJ, Matas AJ et al. Total or near total pancreatectomy and islet autotransplantation for treatment of chronic pancreatitis. *Ann Surg* 1980;192(4):526-542.
9. Shapiro AM, Lakey JR, Ryan EA, Korbutt GS, Toth E, Warnock GL et al. Islet transplantation in seven patients with type 1 diabetes mellitus using a glucocorticoid-free immunosuppressive regimen. *N Engl J Med* 2000;343(4):230-238.
10. Shapiro AM, Ricordi C, Hering B. Edmonton's islet success has indeed been replicated elsewhere. *Lancet* 2003;362(9391):1242.
11. Hering BJ, Kandaswamy R, Ansite JD, Eckman PM, Nakano M, Sawada T et al. Single-donor, marginal-dose islet transplantation in patients with type 1 diabetes. *JAMA* 2005;293(7):830-835.
12. Hering BJ, Matsumoto I, Sawada T, Nakano M, Sakai T, Kandaswamy R et al. Impact of two-layer pancreas preservation on islet isolation and transplantation. *Transplantation* 2002;74(12):1813-1816.
13. Kawamura T, Kuroda Y, Suzuki Y, Fujiwara H, Yamamoto K, Saitoh Y. A new simple two layer (Euro-Collins' solution/perfluorochemical) cold storage method for pancreas preservation. *Transplant Proc* 1989;21(1 Pt 2):1376-1377.
14. Fujino Y, Kuroda Y, Suzuki Y, Fujiwara H, Kawamura T, Morita A et al. Preservation of canine pancreas for 96 hours by a modified two-layer (UW solution/perfluorochemical) cold storage method. *Transplantation* 1991;51(5):1133-1135.
15. Kawamura T, Kuroda Y, Saitoh Y. Long-term preservation of canine pancreas by a new simple cold storage method using perfluorochemical--the two-layer cold storage method (Euro-Collins' solution/perfluorochemical). *Kobe J Med Sci* 1992;38(2):135-145.



16. Hiraoka K, Trexler A, Fujioka B, Guo Z, Zhang HJ, Overland A et al. Optimal temperature in pancreas preservation by the two-layer cold storage method before islet isolation. *Transplant Proc* 2001;33(1-2):891-892.
17. Hiraoka K, Kuroda Y, Suzuki Y, Fujino Y, Tanioka Y, Matsumoto S et al. Outcomes in clinical pancreas transplantation with the two-layer cold storage method versus simple storage in University of Wisconsin solution. *Transplant Proc* 2002;34(7):2688-2689.
18. Tsujimura T, Kuroda Y, Avila JG, Kin T, Oberholzer J, Shapiro AM et al. Influence of pancreas preservation on human islet isolation outcomes: impact of the two-layer method. *Transplantation* 2004;78(1):96-100.
19. Matsumoto S, Zhang G, Qualley S, Clever J, Tombrello Y, Strong DM et al. The effect of two-layer (University of Wisconsin solution/perfluorochemical) preservation method on clinical grade pancreata prior to islet isolation and transplantation. *Transplant Proc* 2004;36(4):1037-1039.
20. Tsujimura T, Kuroda Y, Avila JG, Kin T, Churchill TA, Shapiro AM et al. Resuscitation of the ischemically damaged human pancreas by the two-layer method prior to islet isolation. *Transplant Proc* 2003;35(7):2461-2462.
21. Ricordi C, Fraker C, Szust J, Al-Abdullah I, Poggioli R, Kirlew T et al. Improved human islet isolation outcome from marginal donors following addition of oxygenated perfluorocarbon to the cold-storage solution. *Transplantation* 2003;75(9):1524-1527.
22. Matsumoto S, Kuroda Y. Perfluorocarbon for organ preservation before transplantation. *Transplantation* 2002;74(12):1804-1809.
23. Avgoustiniatos ES, Hering BJ, Papas KK. The rat pancreas is not an appropriate model for testing the preservation of the human pancreas with the two-layer method. *Transplantation* 2006;81(10):1471-1472; author reply 1472.
24. Brandhorst D, Iken M, Brendel MD, Bretzel RG, Brandhorst H. Long-term preservation of the pig pancreas by a one-layer method for successful islet isolation. *Transplant Proc* 2005;37(1):229-230.
25. Caballero-Corbalan J ET, Foss A, Felldin M, Kallen R, Lundgren T, Salmela K, Tibell A, Tufveson G, Korsgren O. No beneficial effect of the two layer method (PFCUW) compared with transportation in UW alone on the outcome of human islet isolation and transplantation: a report of 214 human pancreases. *American Journal of Transplantation* 2006;6(Suppl 2):340.
26. Caballero-Corbalan J, Eich T, Lundgren T, Foss A, Felldin M, Kallen R et al. No beneficial effect of two-layer storage compared with UW-storage on human islet isolation and transplantation. *Transplantation* 2007;84(7):864-869.
27. Kin T, Mirbolooki M, Salehi P, Tsukada M, O'Gorman D, Imes S et al. Islet isolation and transplantation outcomes of pancreas preserved with University of Wisconsin solution versus two-layer method using preoxygenated perfluorocarbon. *Transplantation* 2006;82(10):1286-1290.
28. Arita S AT, Kenmochi T, Enomoto K, Isono K. An Initial Wash-Out Solution for " In Situ Machine Wash Out". *Transplantation Proceedings* 1991;23(5):2589-2591.

29. Dijkhuis CM WD, De Gruyl J, Oldenhof J, Drop A. 24-Hour Isolated Canine Pancreas Preservation on the Belzer Machine. In: European Society for Experimental Surgery 7th Congress; 1972; 1972.
30. Sutherland DE, Morrow CE, Florack G, Kretschmer GJ, Baumgartner D, Matas AJ et al. Cold storage preservation of islet and pancreas grafts as assessed by in vivo function after transplantation to diabetic hosts. *Cryobiology* 1983;20(2):138-150.
31. Toledo-Pereyra LH, Valgee KD, Castellanos J, Chee M. Hypothermic pulsatile perfusion: its use in the preservation of pancreases for 24 to 48 hours before islet cell transplantation. *Arch Surg* 1980;115(1):95-98.
32. Brygner H. Twenty-Four-Hour Preservation of the Duct-Ligated Canine Pancreatic Allograft. *European Surgical Research Journal* 1975;1975(7):341-354.
33. Florack G, Sutherland DE, Heil J, Squifflet JP, Najarian JS. Preservation of canine segmental pancreatic autografts: cold storage versus pulsatile machine perfusion. *J Surg Res* 1983;34(5):493-504.
34. Leeser DB, Bingaman AW, Poliakova L, Shi Q, Gage F, Bartlett ST et al. Pulsatile pump perfusion of pancreata before human islet cell isolation. *Transplant Proc* 2004;36(4):1050-1051.
35. Taylor MJ, Baicu S, Leman B, Greene E, Vazquez A, Brassil J. Twenty-four hour hypothermic machine perfusion preservation of porcine pancreas facilitates processing for islet isolation. *Transplant Proc* 2008;40(2):480-482.
36. Taylor MJ, Baicu S, Greene E, Vazquez A, Brassil J. Islet isolation from juvenile porcine pancreas after 24-h hypothermic machine perfusion preservation. *Cell Transplant* 2010;19(5):613-628.
37. Taylor MJ, Baicu SC. Current state of hypothermic machine perfusion preservation of organs: The clinical perspective. *Cryobiology* 2010;60(3 Suppl):S20-35.
38. Karcz M, Cook HT, Sibbons P, Gray C, Dorling A, Papalois V. An ex-vivo model for hypothermic pulsatile perfusion of porcine pancreata: hemodynamic and morphologic characteristics. *Exp Clin Transplant* 2010;8(1):55-60.
39. Weegman BP, Taylor MJ, Baicu SC, Scott WE, 3rd, Mueller KR, Kitzmann JP et al. Hypothermic Perfusion Preservation of the Pancreas for Islet Grafts: Validation Using a Split Lobe Porcine Model. *Cell Medicine, Part B of Cell Transplantation* 2012;2:105-110.
40. Kenmochi T, Asano T, Nakagouri T, Enomoto K, Isono K, Horie H. Prediction of viability of ischemically damaged canine pancreatic grafts by tissue flow rate with machine perfusion. *Transplantation* 1992;53(4):745-750.
41. Weegman BP, Kirchner VA, Scott WE, 3rd, Avgoustiniatos ES, Suszynski TM, Ferrer-Fabrega J et al. Continuous Real-time Viability Assessment of Kidneys Based on Oxygen Consumption. *Transplant Proc* 2010;42(6):2020-2023.
42. Morris GE, Williams SR, Proctor E, Gadian DG, Browse NL. 31P Nuclear Magnetic Resonance of Rat Pancreatic Grafts. *Transplantation* 1989;47(5):779-784.
43. Scott WE, 3rd, Matsumoto S, Tanaka T, Avgoustiniatos ES, Graham ML, Williams PC et al. Real-time noninvasive assessment of pancreatic ATP levels during cold preservation. *Transplant Proc* 2008;40(2):403-406.

44. Scott WE, 3rd, Weegman BP, Ferrer-Fabrega J, Stein SA, Anazawa T, Kirchner VA et al. Pancreas Oxygen Persufflation Increases ATP Levels as Shown by Nuclear Magnetic Resonance. *Transplant Proc* 2010;42(6):2011-2015.
45. Siech M, Sotak CH, Letko G, Davis MA. A method for in vivo assessment of reversible rat pancreatic ischemia using <sup>31</sup>P NMR spectroscopy at 2.0 tesla. *Magn Reson Imaging* 1995;13(3):463-469.
46. Yoshikawa T, Suzuki Y, Kanashiro M, Li S, Goto T, Tanaka T et al. Objective and rapid assessment of pancreas graft viability using <sup>31</sup>P-nuclear magnetic resonance spectroscopy combined with two-layer cold storage method. *Transplantation* 2004;78(1):78-82.
47. Brown J, Kemp JA, Hurt S, Clark WR. Cryopreservation of human fetal pancreas. *Diabetes* 1980;29 Suppl 1:70-73.
48. Muldrew K. Cryobiology - A Short Course. In: Muldrew K, (ed). *Cryobiology - A Short Course*. 1997.
49. Kemp JA, Mazur P, Mullen Y, Miller RH, Clark W, Brown J. Reversal of experimental diabetes by fetal rat pancreas. I. Survival and function of fetal rat pancreas frozen to -196°C. *Transplantation Proceedings* 1977;9:325-328.
50. Kemp JA, Mullen Y, Weissman H, Heininger D, Brown J, Clark WR. Reversal of diabetes in rats using fetal pancreas stored at -196°C. *Transplantation Proceedings* 1978;26:260-264.
51. Hullett DA, Bethke KP, Landry AS, Leonard DK, Sollinger HW. Successful long-term cryopreservation and transplantation of human fetal pancreas. *Diabetes* 1989;38(4):448-453.
52. Gillies RJ. *NMR in physiology and Biomedicine*. Academic Press Inc., 1994.
53. Günther H. *NMR spectroscopy*.: John Wiley & Sons Ltd., 1980.
54. Hornak JP. *The basics of MRI*. 1996; Available from: [www.cis.rit.edu/htbooks/mri/](http://www.cis.rit.edu/htbooks/mri/)

## **Chapter 2: Real-Time Noninvasive Assessment of Murine Pancreatic ATP Levels with Nuclear Magnetic Resonance Spectroscopy**

In order to demonstrate the potential for NMR spectroscopy to be used in the monitoring of high energy phosphates of pancreata over an extended period of time; for pancreata preserved by a variety of methods of preservation. A study was pursued in the murine and porcine models. This was done to confirm predictions previously obtained from modeling that TLM can supply oxygen to a large portion of 'small' pancreata but not to 'larger' human sized pancreata such as the pig pancreas. The results of this study are presented with the permission of the publisher of the journal 'Transplantation Proceedings', Elsevier (Appendix 2), in the original manuscript: **WE Scott III, S Matsumoto, T Tanaka, ES Avgoustiniatos, ML Graham, PC Williams, LA Tempelman, DER Sutherland, BJ Hering, BE Hammer and KK Papas, Real-Time Noninvasive Assessment of Pancreatic ATP Levels During Cold Preservation, Transplantation Proceedings, 2008 Mar;40(2):403-6.**

Transplantation Proceedings, 40, 403–406 (2008)

**Title:**

Real-Time Noninvasive Assessment of Pancreatic ATP Levels During Cold Preservation

2

**Authors:**

W.E. Scott III, S. Matsumoto, T. Tanaka, E.S. Avgoustiniatos, M.L. Graham, P.C.

Williams, L.A. Tempelman, D.E. Sutherland, B.J. Hering, B.E. Hammer, and K.K. Papas

From the University of Minnesota, Department of Surgery (W.E.S., S.M., T.T., E.S.A., M.L.G., D.E.S., B.J.H., K.K.P.), Diabetes Institute for Immunology and Transplantation, Minneapolis, Minnesota, USA; University of Minnesota, Department of Radiology (P.C.W., B.E.H.), Center for Interdisciplinary Applications in Magnetic Resonance, Minneapolis, Minnesota, USA; and Giner Inc (L.A.T.), Newton, Massachusetts, USA.

---

<sup>2</sup> We would like to thank Dr A.N. Balamurugan, Dr Kristen Maynard, Thomas M. Suszynski, and Bradley P. Weegman from the Diabetes Institute for Immunology and Transplantation for helpful discussions and manuscript review. We would also like to thank Denice Duderio, Laurie Macleod, Heather Nelson, and Christine Vincent from the Diabetes Institute for Immunology and Transplantation at the UMN for administrative support.

Research funding provided by grants from the National Center for Research Resources (U42 RR016598), National Institutes of Health (NIH), National Institute of Diabetes and Digestive and Kidney Diseases (R43 DK070400), NIH, the Schott Foundation, and the Carol Olson Memorial Diabetes Research Fund.

Corresponding author. Address: Institute for Cellular Transplantation, Department of Surgery, University of Arizona, 1656 E. Mabel Street, Room 121, Tucson, AZ 85724, USA. Fax: +1 520 626 7779.

E-mail addresses: [kkpapas@surgery.arizona.edu](mailto:kkpapas@surgery.arizona.edu), [papas006@umn.edu](mailto:papas006@umn.edu) (K.K. Papas).

<sup>31</sup>P-NMR spectroscopy was utilized to investigate rat and porcine pancreatic ATP:P<sub>i</sub> ratios to assess the efficacy of existing protocols for cold preservation (CP) in maintaining organ quality. Following sacrifice, rat pancreata were immediately excised or left enclosed in the body for 15 minutes of warm ischemia (WI). After excision, rat pancreata were stored at 6 °C to 8 °C using histidine-tryptophan-ketoglutarate solution (HTK) presaturated with air (S1), HTK presaturated with O<sub>2</sub> (S2), or the HTK/perfluorodecalin two-layer method (TLM) with both liquids presaturated with O<sub>2</sub> (S3). <sup>31</sup>P-NMR spectra were sequentially collected at 3, 6, 9, 12, and 24 hours of CP from pancreata stored with each of the three protocols examined. The ATP:P<sub>i</sub> ratio for rat pancreata exposed to 15 minutes of WI and stored with S3 increased during the first 9 hours of CP, approaching values observed for organs procured with no WI. A marked reduction in the ATP:P<sub>i</sub> ratio was observed beyond 12 hours of CP with S3. After 6 hours of CP, the ATP:P<sub>i</sub> ratio was highest for S3, substantially decreased for S2, and below detection for S1. In sharp contrast to the rat model, ATP was barely detectable in porcine pancreata exposed to minimal warm ischemia (15 minutes) stored with the TLM regardless of CP time. We conclude that <sup>31</sup>P-NMR spectroscopy is a powerful tool that can be used to (1) noninvasively evaluate pancreata prior to islet isolation, (2) assess the efficacy of different preservation protocols, (3) precisely define the timing of reversible versus irreversible damage, and (4) assess whether intervention will extend this timing.

**Introduction:**

Islet transplantation has become a promising therapeutic alternative for the treatment of a subpopulation of patients with Type 1 diabetes [1, 2]. Currently, clinical islet allotransplantation is limited by a shortage of suitable donor organs as well as by loss of islets during the islet manufacturing process. Islets may be predisposed to death before or during isolation due to improper handling of the organ during procurement and/or suboptimal cold preservation (CP) during transport. Significant research effort has focused on investigating the efficacy of the two-layer method (TLM), the present state of the art for pancreas preservation [3-8]. In the late 1990s, many centers reported improvements in islet isolation outcome using TLM for CP. These improvements were attributed in part to increases in tissue ATP associated with enhanced tissue oxygenation with the TLM compared to the previously used CP in University of Wisconsin (UW) solution alone [3-8]. However, it has recently been reported that the TLM may not be able to sufficiently oxygenate large portions of human or porcine pancreata during CP.<sup>9,10</sup> In addition, recent retrospective studies have suggested no significant improvement in isolation outcomes for pancreata stored with the TLM when compared to pancreata stored on UW solution alone [11-13]. Therefore, it is of great importance to develop tools that will aid in the assessment of the efficacy of presently utilized CP techniques (eg, TLM) as well as in the analysis of novel approaches to CP. In this study <sup>31</sup>P-NMR spectroscopy (<sup>31</sup>P-NMR), a well-established technique for monitoring the amount of ATP present relative to inorganic phosphate (P<sub>i</sub>) in tissues, was used to assess the efficacy of current CP methods to maintain the health of pancreata. <sup>31</sup>P-NMR has been extensively used to study tumor biology, bioenergetics, as well as metabolism and health status of organs,

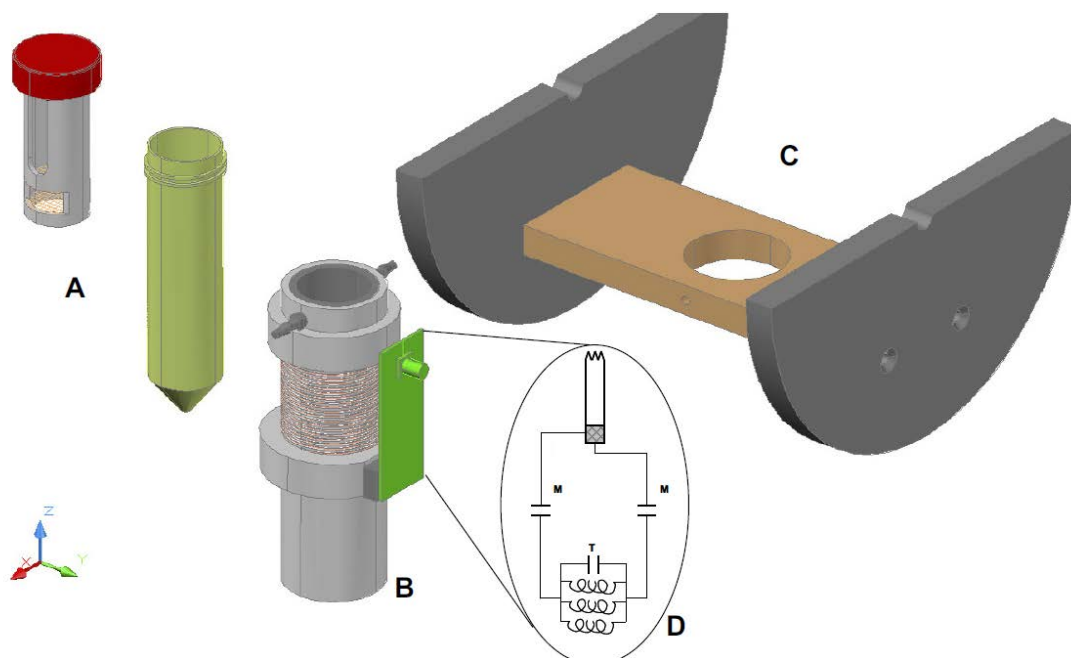
such as the heart, brain, kidney, liver, and, to a limited extent, the pancreas [14-22]. The noninvasive nature of  $^{31}\text{P}$ -NMR and its ability to provide information in real time make it an attractive tool for monitoring the health of pancreata during CP, which is the focus of this study.

### **Methods:**

Male Lewis rats and female Landrace pigs were sacrificed using institutionally approved procedures. Rat pancreata were immediately excised or left enclosed in the body for 15 minutes of warm ischemia (WI). Porcine pancreata were excised as soon as possible (less than 15 minutes). After procurement, pancreata were placed directly into prechilled preservation solution (300 mL for rats or 2 L for pigs) and stored in a thermoelectrically refrigerated cooler at 6 °C to 8 °C using one of three CP techniques: histidine-tryptophan ketoglutarate (HTK) + air, HTK solution presaturated with air (S1); HTK + O<sub>2</sub>, HTK solution presaturated with O<sub>2</sub> (S2); and TLM + O<sub>2</sub>, HTK/perfluorodecalin, two-layer method with both solutions presaturated with O<sub>2</sub> (S3). All storage solutions were either recharged with oxygen or exposed to air for 15 minutes every 3 hours and spectra were acquired after 3, 6, 9, 12, and 24 hours of CP. During data acquisition, the rat pancreata were placed into a custom-made container designed to hold 44 mL of CP solution. The container was placed inside a radiofrequency coil tuned to 86.025 MHz, then positioned in the center of the bore of a horizontal 5 T magnet maintained at 6 °C. The solenoid coil had a total length of 1.8 cm and a diameter of 3.5 cm and consisted of 3 three-turn coils bridged by a 5-pF chip capacitor in the center of each coil, with each of the coils connected in parallel. The solenoid coil was attached to a balanced configuration



circuit with variable 4 to 18 pF capacitors for the tuning and matching. A schematic depicting the rat pancreas container is shown in **Figure 2.1**.



**Figure 2.1:**

A three-dimensional rendering of the rat pancreas cold preservation container (A), solenoid coil (B), and the platform (C) used to center the coil in the bore of the magnet, used for the acquisition of the  $^{31}\text{P}$ -spectra shown in **Figure 2.2**. Also shown is a circuit diagram (D) for the coil used in the study.

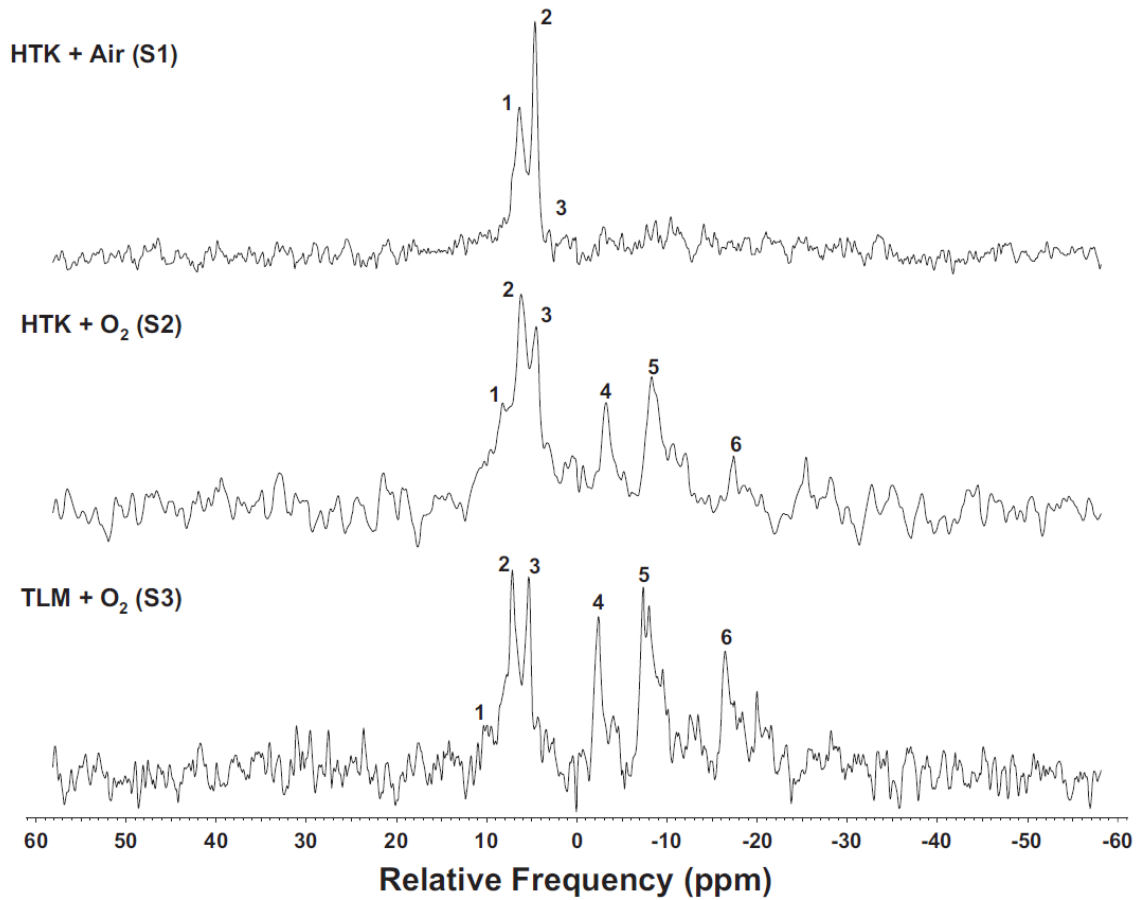
Porcine organs were investigated at 1.5 T using a 7-cm diameter surface coil tuned to 25.5085 MHz.  $^{31}\text{P}$ -NMR spectra were collected using 1024 scans with 2048 points, a dwell time of 100 seconds, and a relaxation time of 1 second. All spectra were analyzed with an exponential line broadening of 25 using the ACD Labs 1-D NMR Processor software (Toronto, Ontario, Canada) by fitting a Lorentzian function to all discernible

peaks. The areas of the  $\alpha$ -,  $\beta$ -, and  $\gamma$ -ATP peaks were summed and normalized to the area of the  $P_i$  peak to obtain the ATP: $P_i$  ratio used to compare the metabolic health of the organs.

### **Results:**

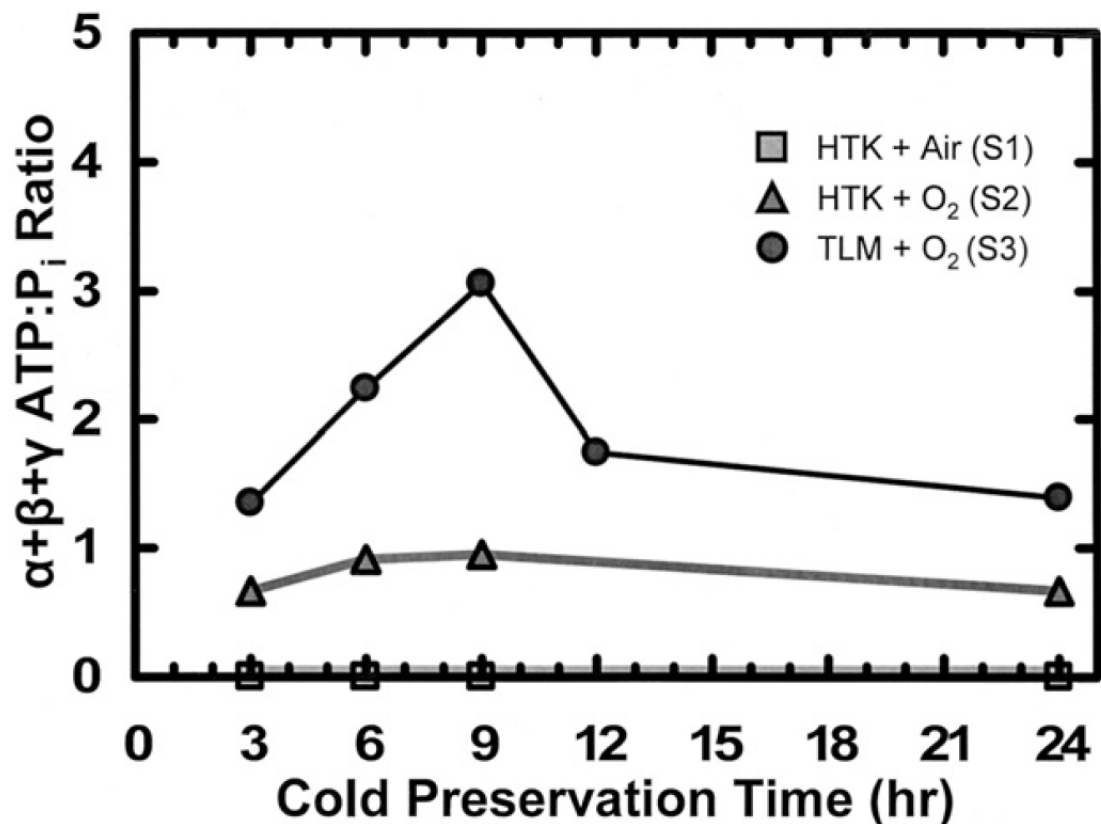
Spectra obtained from rat pancreata treated with each of the three methods of CP exhibited differences in the ATP: $P_i$  ratio that were large enough to be obvious upon basic visual inspection (**Figure 2.2**). The plot of ATP: $P_i$  for S1, S2, and S3 versus time is shown in **Figure 2.3**. For HTK + air (S1), no ATP peaks were detected throughout the preservation period. For HTK + O<sub>2</sub> (S2), the ratio ATP: $P_i$  trended slightly upward for the first 9 hours but leveled off and even decreased slightly at 24 hours. For TLM + O<sub>2</sub> (S3), the ATP: $P_i$  ratio was substantially higher than both HTK conditions and increased for the first 9 hours of CP. This increase was followed by a precipitous drop at 12 hours, and the ratio leveled out at 24 hours to values similar to those obtained with S2. TLM for CP was also investigated in the porcine model system; however, no discernible ATP peaks were detected in any of the organs examined.

## PANCREATIC ATP LEVELS



**Figure 2.2:**

$^{31}\text{P}$ -NMR spectra acquired from rat organs exposed to 15 minutes of WI following 9 hours of cold preservation. Method of cold preservation: HTK + air (S1); HTK + O<sub>2</sub> (S2); TLM + O<sub>2</sub> (S3). Peak numbering corresponds to: (1) phosphomonoester, (2) inorganic phosphate, (3) phosphodiester, (4)  $\gamma$ -ATP, (5)  $\alpha$ -ATP, and (6)  $\beta$ -ATP.



**Figure 2.3:**

Plot of  $\alpha + \beta + \gamma$  ATP: $P_i$  ratios versus time of cold preservation. Rat pancreata were placed into a custom-made container with 44 mL of the appropriate cold preservation solution(s). The container was placed into a coil, which was tuned to 86.025 MHz and centered in a 5 T magnet maintained at 6 °C. Three separate CP methods were compared: HTK + air (S1); HTK + O<sub>2</sub> (S2); TLM + O<sub>2</sub> (S3). All storage solutions were either recharged with O<sub>2</sub> or exposed to air for 15 minutes every 3 hours and spectra were acquired after 3, 6, 9, 12, and 24 hours of cold preservation. During data acquisition, the <sup>31</sup>P-NMR spectra were collected for 1024 scans with 2048 points, a dwell time of 100 seconds, and a relaxation time of 1 second. Spectra were analyzed with an exponential line broadening of 25 by fitting a Lorentzian function to all discernible peaks. The areas

of the  $\alpha$ -,  $\beta$ -, and  $\gamma$ -ATP peaks were summed and normalized to the area of the  $P_i$  peak to obtain the ratios shown.

### **Discussion:**

In this article, we utilized  $^{31}\text{P}$ -NMR spectroscopy to noninvasively assess the efficacy of different preservation protocols in maintaining ATP levels (as indicated by the ATP: $P_i$  ratio, a measure of organ health and viability) in rat and porcine pancreata. Results demonstrated that in the rat pancreas model, CP with TLM results in dramatically improved ATP: $P_i$  ratio levels when compared to CP in HTK solution exposed to air alone, the previous state of the art. Furthermore, preservation of rat pancreata in HTK solution saturated with  $\text{O}_2$  demonstrated a minor improvement in ATP: $P_i$  ratios but to a smaller extent compared to the improvement observed with TLM (**Figure 2.3**). These results demonstrate that TLM is indeed effective in improving oxygenation and elevating ATP levels in the rat pancreas model. However, when porcine pancreata stored with TLM were investigated, no discernible ATP peaks were observed, indicating that TLM may be less effective in this model. These data may help explain why the success of TLM with the rat and canine pancreas models has not been fully translated to the preservation of clinical organs [11-13] and are consistent with previously published studies [9, 10], which suggest that TLM cannot fully oxygenate the larger porcine and human pancreata. The increase in the ATP: $P_i$  ratio with time over the first 9 hours of CP with the TLM may reflect the dynamics of reoxygenation and ATP regeneration following ischemia during procurement. This increase is consistent with the observation in the rat model by Tanaka and coworkers that pancreata exposed to moderate periods of WI yielded significantly

more islets when isolation was performed after 3 to 6 hours of CP with the TLM as opposed to shortly after procurement [23]. Furthermore, the marked reduction in the ATP:Pi ratio after 12 hours of CP that we observed is also consistent with the observation that isolation yields generally decrease after 8 to 9 hours of CP [24] and may be indicative of the presence of additional and important factors limiting CP. Based on our results, we conclude that the noninvasive nature and the ability of  $^{31}\text{P}$ -NMR to provide information in real time make it an effective and powerful tool for identifying the factors currently limiting CP and for assessing and establishing new and improved methods for organ preservation.

## References:

1. Shapiro AM, Lakey JR, Ryan EA, et al: Islet transplantation in seven patients with type 1 diabetes mellitus using a glucocorticoid-free immunosuppressive regimen. *N Engl J Med* 343:289, 2000
2. Shapiro AM, Ricordi C, Hering B: Edmonton's islet success has indeed been replicated elsewhere. *Lancet* 362:1242, 2003
3. Hiraoka K, Kuroda Y, Suzuki Y, et al: Outcomes in clinical pancreas transplantation with the two-layer cold storage method versus simple storage in University of Wisconsin solution. *Transplant Proc* 34:2688, 2002
4. Tsujimura T, Kuroda Y, Avila JG, et al: Influence of pancreas preservation on human islet isolation outcomes: impact of the two-layer method. *Transplantation* 78:96, 2004
5. Matsumoto S, Zhang G, Qualley S, et al: The effect of two-layer (University of Wisconsin solution/perfluorochemical) preservation method on clinical grade pancreata prior to islet isolation and transplantation. *Transplant Proc* 36:1037, 2004
6. Tsujimura T, Kuroda Y, Avila JG, et al: Resuscitation of the ischemically damaged human pancreas by the two-layer method prior to islet isolation. *Transplant Proc* 35:2461, 2003
7. Ricordi C, Fraker C, Szust J, et al: Improved human islet isolation outcome from marginal donors following addition of oxygenated perfluorocarbon to the cold-storage solution. *Transplantation* 75:1524, 2003
8. Matsumoto S, Kuroda Y: Perfluorocarbon for organ preservation before transplantation. *Transplantation* 74:1804, 2002
9. Avgoustiniatos ES, Hering BJ, Papas KK: The rat pancreas is not an appropriate model for testing the preservation of the human pancreas with the two-layer method. *Transplantation* 81:1471, 2006
10. Papas KK, Hering BJ, Guenther L, et al: Pancreas oxygenation is limited during preservation with the two-layer method. *Transplant Proc* 38:3501, 2005
11. Kin T, Mirbolooki M, Salehi P, et al: Islet isolation and transplantation outcomes of pancreas preserved with University of Wisconsin solution versus two-layer method using preoxygenated perfluorocarbon. *Transplantation* 82:1286, 2006
12. Caballero-Corbalán J, Eich T, Foss A, et al: No beneficial effect of the two layer method (PFCUW) compared with transportation in UW alone on the outcome of human islet isolation and transplantation: a report on 214 human pancreases. *Am J Transplant* 6(suppl 2):340, 2006
13. Caballero-Corbalán J, Eich T, Lundgren T, et al: No beneficial effect of two-layer storage compared with UW-storage on human islet isolation and transplantation. *Transplantation* 84:864, 2007
14. Arias-Mendoza F, Brown TR: In vivo measurement of phosphorous markers of disease. *19:49*, 2004
15. Dobbins RL, Malloy CR: Measuring in-vivo metabolism using nuclear magnetic resonance. *Curr Opin Clin Nutr Metab Care* 6:501, 2003
16. Horn M: Cardiac magnetic resonance spectroscopy: a window for studying physiology. *Methods Mol Med* 124:225, 2006
17. Barnard ML, Changani KK, Taylor-Robinson SD: The role of magnetic resonance spectroscopy in the assessment of kidney viability. *Scand J Urol Nephrol* 31:487, 1997

18. Davidson BR, Barnard ML, Changani KK, et al: Liver transplantation: current and potential applications of magnetic resonance spectroscopy. *Liver Transpl Surg* 3:481, 1997
19. Khan SA, Cox IJ, Hamilton G, et al: In vivo and in vitro nuclear magnetic resonance spectroscopy as a tool for investigating hepatobiliary disease: a review of H and P MRS applications. *Liver Int* 25:273, 2005
20. Gillies RJ, Morse DL: In vivo magnetic resonance spectroscopy in cancer. *Annu Rev Biomed Eng* 7:287, 2005
21. Ishii S, Sato Y, Terashima M, et al: A novel method for determination of ATP, ADP, and AMP contents of a single pancreatic islet before transplantation. *Transplant Proc* 36:1191, 2004
22. Siech M, Sotak CH, Letko G, et al: A method for in vivo assessment of reversible rat pancreatic ischemia using <sup>31</sup>P NMR spectroscopy at 2 tesla. *Magn Reson Imaging* 13:463, 1995
23. Tanaka T, Suzuki Y, Tanioka Y, et al: Possibility of islet transplantation from a nonheartbeating donor pancreas resuscitated by the two-layer method. *Transplantation* 80:738, 2005
24. Paget M, Murray H, Bailey CJ, et al: Human islet isolation: semi-automated and manual methods. *Diab Vasc Dis Res* 4:7, 2007



## **Chapter 3: Vascular and Ductal Anatomy of the Porcine**

### **Pancreas**

Armed with the knowledge that small animal models are unsuitable for the development of novel methods of organ preservation, particularly if oxygen plays a significant role in preservation and alternate model of a similar scale to the human had to be developed. The pig emerged as an ideal candidate due to its similar or slightly greater sized pancreas when compared with the human as well as the ability to consistently isolate islets. The University of Minnesota in particular is one of the world leaders in porcine islet isolation and so the porcine pancreas was pursued as a model. One hurdle to the use of the porcine pancreas is that its anatomy is dramatically different than that found in the human. Additionally, the literature contained only scattered and inconsistent accounts of the vascular and ductal anatomy. It was decided that if either of these 2 natural pathways into the pancreas for were to be consistently utilized for the active delivery of oxygen or other cytoprotective agents; that a concrete understanding of the anatomy of the porcine pancreas was required. A detailed anatomical study was performed paying particular attention to the ductal and vascular anatomy and their variations. The results of the study are summarized in the original manuscript: **J Ferrer, WE Scott III, BP Weegman, TM Suszynski, DER Sutherland, BJ Hering, KK Papas, Pig Pancreas Anatomy: Implications for Pancreas Procurement, Preservation, and Islet Isolation, Transplantation, 2008 Dec; 86(11): 1503-1510;** included with the permission of the publisher of the journal 'Transplantation', Wolters Kluwer Health (Appendix 3).

My contributions to this work spanned the conception, execution and analysis, as well as contributions to the discussion.

Transplantation, 86(11), 1503–1510 (2008)

**Title:**

Pig Pancreas Anatomy: Implications for Pancreas Procurement, Preservation, and Islet Isolation<sup>3</sup>

**Authors:**

Joana Ferrer, William E. Scott III, Bradley P. Weegman, Thomas M. Suszynski, David E. R. Sutherland, Bernhard J. Hering, and Klearchos K. Papas<sup>A, B</sup>

<sup>A</sup> Department of Surgery, Diabetes Institute for Immunology and Transplantation, University of Minnesota Medical School, Minneapolis, MN.

<sup>B</sup> Address correspondence to: Klearchos K. Papas, Department of Surgery, Diabetes Institute for Immunology and Transplantation, University of Minnesota Medical School, Mayo Mail Code 195, 420 Delaware Street SE, Minneapolis, MN 55455.

E-mail: papas006@umn.edu

---

<sup>3</sup> This work was supported by National Institutes of Health (NIH), National Institute of Diabetes and Digestive and Kidney Diseases (R01DK068717 and R43 DK070400), The Iacocca Foundation, The Schott Foundation, and The Carol Olson Memorial Diabetes Research Fund.

The authors thank Efstathios Avgoustiniatos, Louis Kidder, Kristen Maynard, Phillip Rozak, and Kate Mueller for assistance in article preparation and review; A.N. Balamurugan and Melanie Graham for helpful discussions; and Shuichiro Matsumoto, Takayuki Anazawa, Thomas Gilmore, Brian Perrault, and Lucas Mutch for surgical assistance.

**Background.** Islet transplantation is emerging as a treatment option for selected patients with type 1 diabetes. The limited human islet supply from cadavers and poor islet yield and quality remain substantial impediments to progress in the field. Use of porcine islets holds great promise for large-scale application of islet transplantation. Consistent isolation of porcine islets is dependent on advances in pancreas procurement, pancreas preservation, and islet isolation, requiring detailed knowledge of the porcine pancreatic anatomy. The primary aim of this study was to describe the vascular and ductal anatomy of the porcine pancreas to guide and improve organ preservation and enzyme perfusion.

**Methods.** Pancreata were removed by en bloc viscerectomy from 65 female Landrace pigs.

**Results.** 15% of organs exhibited inconsistent vascular branching from the celiac trunk. All organs showed uniform patterns of branching at the superior mesenteric artery. The superior and inferior mesenteric veins merged to become the portal vein in all but one case in which the inferior mesenteric vein drained into the splenic vein. 97% of pancreata had 3 lobes: duodenal lobe (DL), connecting lobe (CL), and splenic lobe (SL); 39% demonstrated ductal communication between the CL and the other two lobes; 50% had ductal communication only between the CL and duodenal lobe; and 11% presented other types of ductal delineation.

**Conclusions.** Accounting for the variations in vascular and ductal anatomy, as detailed in this study, will facilitate development of protocols for preservation, optimal enzyme administration, and pancreas distention and digestion, and will ultimately lead to substantial improvements in isolation outcomes.

**Keywords:**

Pancreatic islet transplantation

Porcine pancreas anatomy

Surgical diabetes management

**Introduction:**

Islet transplantation (ITx) is a promising treatment option for selected patients with type 1 diabetes [1, 2]. Increasing evidence demonstrates the ability of human islet allografts to consistently restore normoglycemia and insulin independence in immunosuppressed recipients without the procedural risks associated with vascularized pancreas transplantation [3–9]. Technical and immunological challenges, however, remain before larger-scale, cost-effective application of ITx is possible. Technical challenges relate to the limited human islet supply from cadavers and to the low islet yield and quality associated with donor brain death and long cold-ischemia times during organ procurement, storage, and transportation [10–13].

The use of islets isolated from pig pancreata, a source with an unlimited supply [14], will have a marked impact as it will enable the application of ITx to a larger segment of the population in need. The recent achievement of long-term diabetes reversal after porcine islet xenotransplantation in nonhuman primates demonstrated the potential of islet xenotransplantation in humans [15, 16].

In addition to addressing safety concerns, clinical use of porcine islets will also require the development and implementation of protocols that maximize the viable islet yield per donor pig pancreas [17, 18]. Consistent isolation of large numbers of high-quality islets from porcine donors is dependent on advances in organ procurement, organ preservation, and islet isolation, all of which will benefit from detailed knowledge of the porcine pancreatic anatomy [19–21]. Even though studies of porcine pancreatic anatomy have

been previously published [22], the detailed information needed for optimizing pancreas preservation and ductal perfusion is unavailable. Because variations in porcine anatomy have been reported as limiting in these studies [23, 24], it is important to establish an understanding of the extent and implications of such anatomical variations of the pig pancreas in the context of pancreas procurement, pancreas preservation, and islet isolation.

The first goal of this investigation was to gain a detailed understanding of the porcine pancreas vascular anatomy so as to facilitate the development and implementation of improved procurement and perfusion-based preservation techniques. The second goal was to develop a better understanding of the ductal branching structure and gain critical knowledge so as to facilitate the development of improved techniques for ductal enzyme loading for optimal pancreas distention before islet isolation.

### **Methods:**

A total of 65 female Landrace nonheart beating donor pigs were pancreatectomized to study the vascular and ductal anatomy of the pancreas. The age of the animals was between 6 and 24 months. The mean weight was  $452 \pm 99$  lb, with a range between 248 and 680 lb. All experiments were conducted according to the rules and regulations of the Institutional Animal Care and Use Committee of the University of Minnesota. Animals received an intravenous administration of heparin, killed by sodium pentobarbital overdose, and then, following the cessation of heart rhythm, completely bled out and eviscerated. All of the internal organs were placed onto a procurement table. The

pancreas was then removed by *en bloc* viscerectomy to study the pancreatic lobes and general anatomy. The vasculature was studied in situ by dissecting and identifying all the vessels that supply the pancreas, allowing for the investigation of perfusion-based preservation techniques. The pancreatic vascular supply and ductal drainage systems were studied after organ procurement by the infusion of colored 0.9% NaCl saline.

### **Surgical Procedure**

1. Once all the internal organs were out of the pig abdominal cavity, the greater omentum was incised.
2. The peritoneum that covers the surface of the viscera was opened and the tail of the pancreas (distal splenic lobe [SL]) was dissected from its posterior attachments starting laterally adjacent to the spleen. The upper and lower margins of the pancreatic tail were freed of their mesenteric attachments. The tail of the pancreas was isolated and the spleen was then mobilized.
3. The distal splenic artery and vein were divided to the left of the pancreas.
4. With the splenic artery as a landmark, the celiac trunk (CT) was located and dissected to expose the upper part of the abdominal aorta.
5. The tail and distal portions of the body (proximal SL) of the pancreas were mobilized to the junction of the splenic vein, superior mesenteric vein (SMV), and portal vein (PV).
6. The posterior attachments of the pancreas and all tissues between the splenic artery and the junction of the splenic vein and PV were divided.
7. The dissection between the left adrenal gland and the pancreas was later determined to provide more rapid access to the CT, the superior mesenteric artery (SMA), and the aorta,



which was isolated by sectioning the fibromuscular extensions of the diaphragmatic crura and the abdominal lymphatic duct.

8. Dissection continued along the superior margin of the pancreas. The left gastric artery (LGA) was divided at its origin from the splenic artery. The body of the pancreas wraps the PV with a large anterior and thin posterior ring, termed the “portal ring.”

9. After dissecting the hepatoduodenal ligament, the common bile duct (which enters proximally into the duodenum on the major duodenal papilla, 2 to 5 cm from the pylorus) was cutoff at its entrance into the duodenum, and the proper hepatic and gastroduodenal arteries were ligated.

10. The body of the pancreas and the connecting lobe (CL) were dissected free from the PV by ligating the vascular branches between them.

11. The head of the pancreas (duodenal lobe [DL]) was then dissected and mobilized to the right of the aorta. The head of the pancreas is in a C-shape with respect to the duodenum and is attached to the second, third, and fourth parts of the duodenum. The duodenum was pulled up and the pancreas was dissected free from the right portion of the PV and the infrahepatic vena cava.

12. The pancreas was then carefully separated from the pancreaticoduodenal vascular arcade so that the pancreatic branches of this vessel could be individually ligated.

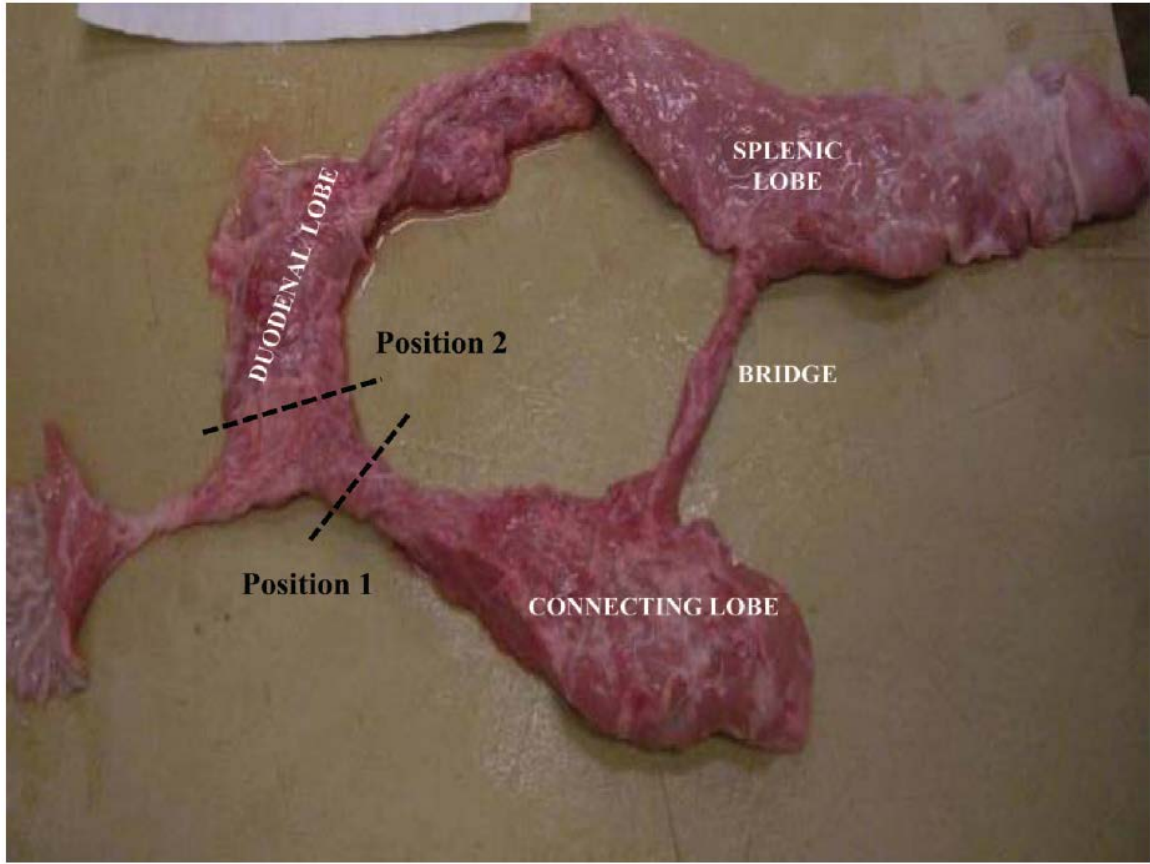
13. The main pancreatic duct opens approximately 20 cm distally into the second (descending) portion of the duodenum. The peritoneum on the right side and behind the lower part of the duodenum was subsequently incised and the transverse colonic ligament was sharply dissected to expose the SMA and the SMV.

14. The right part of the CT, the SMA, and the aorta were then isolated.

15. The inferior pancreatic artery was also ligated, after the dissection of the SMA in the root of the aorta, approximately 2 cm caudal to the CT.
16. The pancreas was excised by dissection and individual ligation and division of the small vessels from the SMA to the pancreas.
17. The portal ring around the PV was dissected free from the surrounding structures.
18. The proximal and distal duodenum were ligated and transected.
19. The inferior and anterior aspect of the gland is attached to the mesocolon, which had to be transected to remove the organ in finishing the total pancreatectomy.
20. The pancreas was ready to be removed after sectioning of the portal ring and after transection of the vasculature.

### **Pancreatic Lobes**

The porcine pancreas is composed of three lobes featuring a nodular surface with irregular margins (**Figure 3.1**). The “splenic” lobe (corresponding to the tail and body in the human pancreas) is situated posteriorly and is attached to the spleen and the stomach. The “duodenal” lobe (corresponding to the head of the pancreas) is located adjacent to the duodenum while the “connecting” lobe (corresponding to the uncinate process) is an extension of the pancreas which is attached to the anterior aspect of the PV. There is a “bridge” of pancreatic tissue serving as an anatomical connection between the splenic and connecting lobes (CLs).



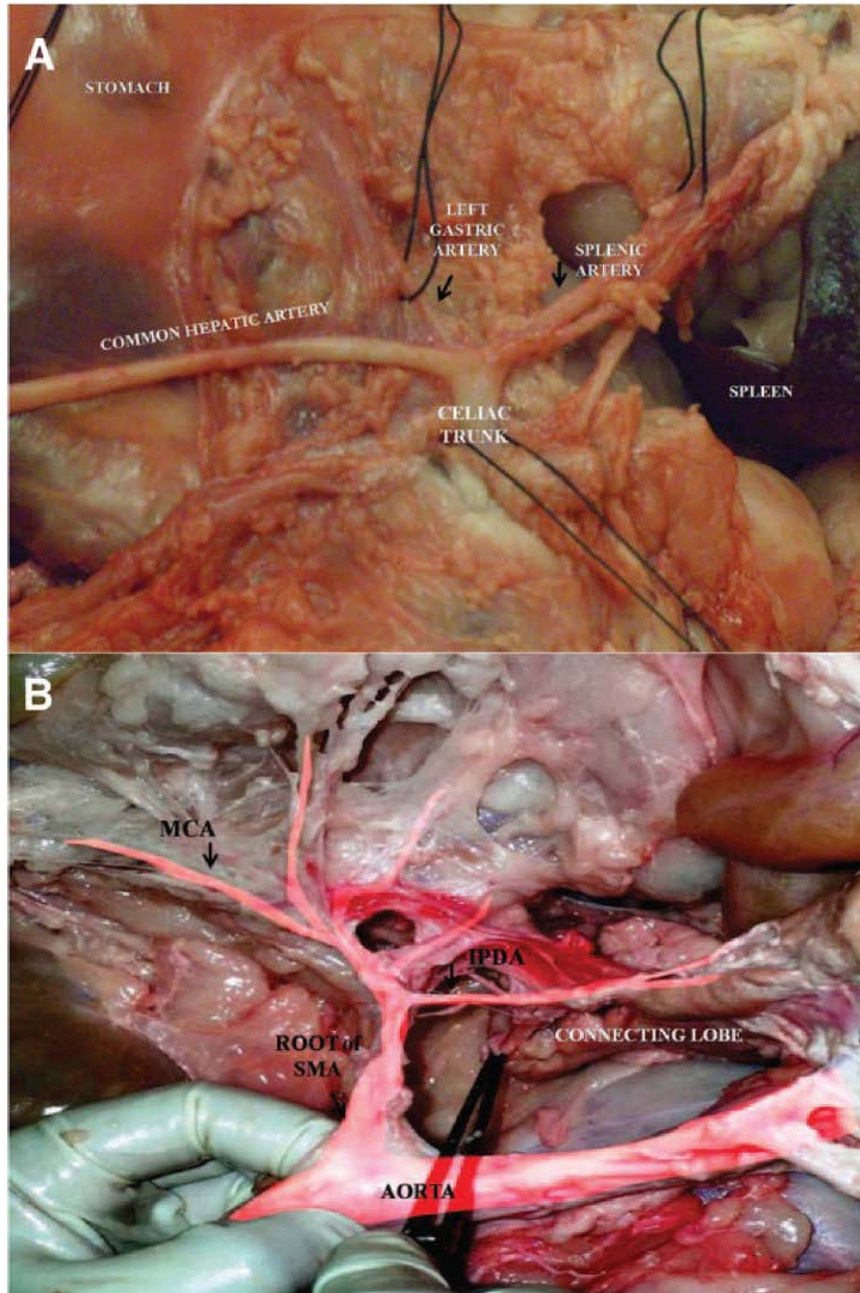
**Figure 3.1:**

Photograph of an excised pig pancreas exhibiting normal anatomy with the duodenal, splenic, and connecting lobes, as well as the bridge. Position 1: dotted lines indicate the positioning of the clamp restricting flow to the connecting lobe. Position 2: dotted lines indicate the positioning of the clamp restricting flow to the duodenal lobe.

### **Arterial Anatomy**

The abdominal aorta is retroperitoneal. The viscera had to be moved aside and the parietal peritoneum had to be removed to locate the aorta. The aorta was immediately dissected from the rest of the tissue. The CT was the first branch of the abdominal aorta infradiaphragmatically and branched into the splenic artery, the LGA, and the common

hepatic artery, as is common in human (**Figure 3.2A**). These arteries were immediately identified and transected distally to the pancreas. The splenic artery was the first branch identified, dissected, and tied. The posterior pancreatic artery (PPA) or dorsal pancreatic artery is a small pancreatic branch originating from the splenic or hepatic artery and was next identified along the upper border of the pancreas. In some cases, the PPA can have its origin more proximal off of the splenic artery, but distal to the celiac trifurcation. In some animals, more than one PPA were identified with large variability in size. The other two main branches from the CT were then identified. The first was the LGA, which runs parallel to the left gastric vein to supply the stomach, and the other was the common hepatic artery that supplies the liver with arterial blood. The proper hepatic artery and common bile duct were ligated and divided. The gastroduodenal artery arises from the hepatic artery before its bifurcation into the right and left hepatic artery. The pyloric region of the gastroduodenal artery exhibits two branches that supply the DL of the pancreas: (1) the superior pancreaticoduodenal artery and (2) the right gastroepiploic (or gastro-omental) artery. The superior pancreaticoduodenal artery supplies the descending duodenum in addition to the DL. This artery anastomoses with the inferior pancreaticoduodenal artery that originates from the SMA. The pancreaticoduodenal vascular arcade runs between the pancreas and the duodenum, and also extends branches to both organs.

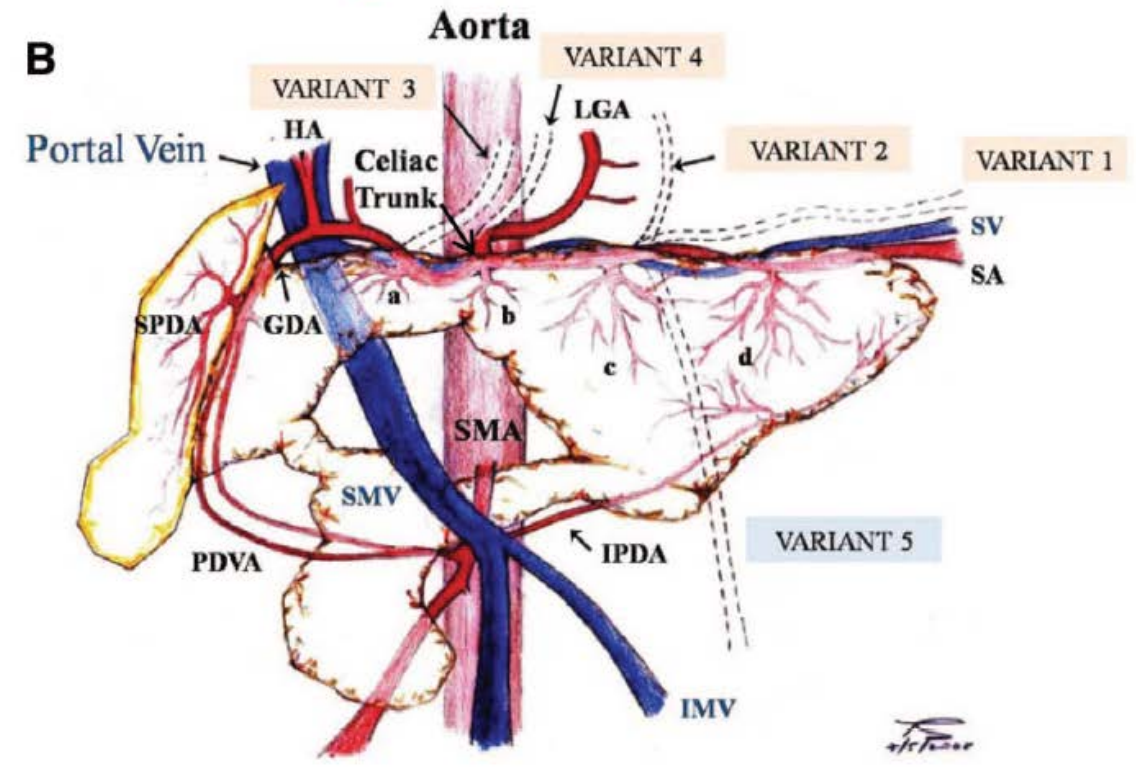
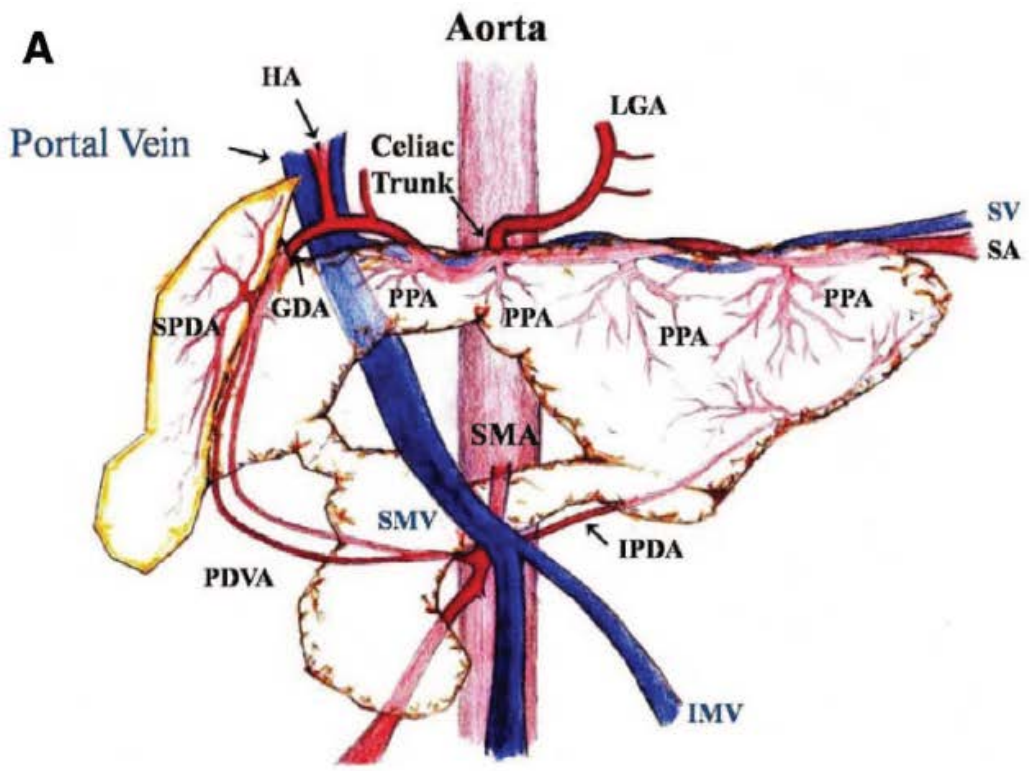


**Figure 3.2:**

(A) Celiac trunk and the main branches (splenic artery, hepatic artery, and left gastric artery). (B) Arterial system (superior mesenteric artery with distal branches). The branch of SMA to pancreas (IPDA) is distributed mainly in the connecting lobe. SMA, superior mesenteric artery; IPDA, inferior pancreaticoduodenal artery; MCA, middle colic artery.

Caudal to the CT was the SMA and the renal arteries (found by following the abdominal aorta to the level of the kidneys). The SMA and the SMV were isolated at the lower edge of the pancreas on the left side of the PV. The SMA gives branches (jejunal arteries, right colic artery, middle colic artery, and ileocolic artery) that supply the distal part of the descending duodenum to the proximal part of the ascending colon. The CL, the bridge, and the inferior aspect of the SL are vascularized by an arterial branch, the inferior pancreatic artery, which emerges from the inferior pancreaticoduodenal arterial arcade (**Figure 3.2B**).

To study which lobes are supplied by which main arteries, the aorta was cut open longitudinally and then the CT and the SMA were cannulated separately. Then, colored saline was infused through them to highlight (by introducing visible contrast) the distribution of the arterial blood supply. Once the infusion was completed, the vascular anatomy was mapped by recording the regions supplied by the CT and SMA, respectively, and by dissecting to determine the borders of these regions. The differently colored saline infusions were surprisingly visible, even to the naked eye. The normal pig pancreatic anatomy along with the major variants is presented in **Figure 3.3 (A and B)**.



**Figure 3.3:**

Diagram of (A) normal vascular pancreatic anatomy and (B) the major variants of vascular pancreatic anatomy. (A) GDA, gastroduodenal artery; HA, hepatic artery; IMV, inferior mesenteric vein; IPDA, inferior pancreaticoduodenal artery; LGA, left gastric artery; PDVA, pancreaticoduodenal vascular arcade; PPA, posterior pancreatic artery; SA, splenic artery; SMA, superior mesenteric artery; SMV, superior mesenteric vein; SPDA, superior pancreaticoduodenal artery; SV, splenic vein. (B) (a) posterior pancreatic artery from the hepatic artery; (b) posterior pancreatic artery from the celiac trunk; (c) posterior pancreatic artery from the proximal splenic artery; (d) posterior pancreatic artery from the distal splenic artery. GDA, gastroduodenal artery; HA, hepatic artery; IMV, inferior mesenteric vein; IPDA, inferior pancreaticoduodenal artery; LGA, left gastric artery; PDVA: pancreaticoduodenal vascular arcade; SA, splenic artery; SMA, superior mesenteric artery; SMV, superior mesenteric vein; SPDA, superior pancreaticoduodenal artery; SV, splenic vein. VARIANT 1: “Accessory” splenic artery traveling along with the splenic artery; VARIANT 2: LGA from the splenic artery; VARIANT 3: LGA from the common hepatic artery; VARIANT 4: LGA from the CT; VARIANT 5: Inferior mesenteric vein draining into the splenic vein.



### **Venous Blood Outflow (Drainage)**

The PV collects the blood from stomach, pancreas, intestine, and spleen. The PV, on its way from the root of the mesentery to the liver, penetrates the pancreas at an acute angle so that it lies caudally on the ventral surface and rostrally on the dorsal surface of the pancreas. The PV has two branches that drain into it, the splenic vein and the SMV. The splenic vein drains the body and tail of the pancreas, and it is partly surrounded by pancreatic tissue. Veins draining blood from the stomach (left gastric vein, left gastroepiploic vein) also come out into the splenic vein.

The SMV passes through the portal ring receiving the inferior pancreaticoduodenal vein. The inferior mesenteric vein (IMV) usually flows into the SMV, which would be considered an unusual variation in the human anatomy. Small branches drain the CL into the SMV. The gastroduodenal vein empties into the SMV immediately before its junction with the splenic vein. The gastroduodenal vein receives small veins from the DL. Peripherally, the gastroduodenal vein receives the superior pancreaticoduodenal vein that anastomoses with the inferior pancreaticoduodenal vein.

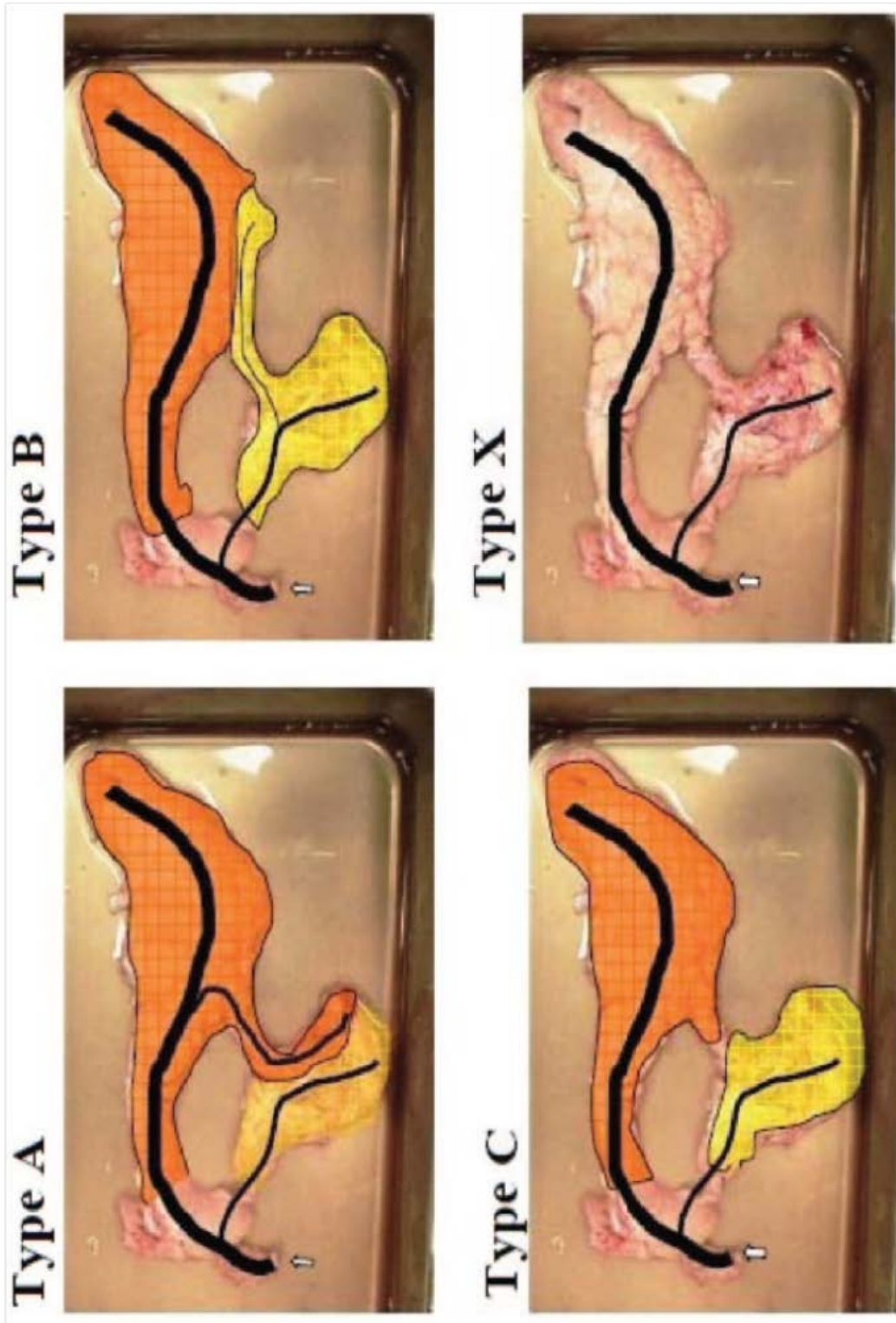
### **Pancreatic Duct**

After dissection, the pancreas was removed from the viscera using an en bloc style procurement technique and placed onto a cooled dissection tray for trimming. The next step was the cannulation of the pancreatic papilla. In some cases, the pancreatic duct was cannulated in situ during the dissection of the viscera. Ductal anatomy was investigated by infusing colored saline into the main pancreatic duct while clamping access to the CL

(position 1 in **Figure 3.1**) and tracing the color change. Next, the CL was infused with a differently colored saline solution while access to the DL was clamped off (position 2 in **Figure 3.1**). The pancreas was then further dissected to determine the extent of ductal communication between the lobes. A classification scheme for the different types of pancreatic ductal networks was designed by observing the ductal anatomy (**Figure 3.4**).

### **Statistical Analysis**

We performed a descriptive analysis of the number of cases reporting median and extreme, average, and standard deviation. For statistical analyses, we used the Statistical Package for Social Sciences program (SPSS Inc., Chicago, IL).



**Figure 3.4:**

Classification of the different duct types.

## **Results:**

The pig pancreas is a retroperitoneal organ, with comparable anatomical orientation and localization to the human. However, there are significant differences between the pig and human pancreas with respect to the number and distribution of the pancreatic lobes. In our series, 63 of the 65 porcine pancreata examined (97%) exhibited the three lobes (duodenal, splenic, and connecting) that we considered the normal representation of the pancreas in the porcine model (**Figure 3.1**). One pancreas presented no “bridging tissue” between the SL and the CL, and another case exhibited a “ringshaped” pancreas (the PV ran parallel to the duodenum and both were covered by the DL). A third pancreas that showed the three expected lobes also contained an additional piece or elongation of pancreatic tissue extending from the SL.

After the pig pancreas was removed and trimmed each organ was weighed. The mean weight of the whole trimmed gland was  $347 \pm 103$  g, with a range from 190 to 698 g. The mean weight of the different lobes was as follows: duodenal,  $75 \pm 9$  g (range, 68–85 g); splenic,  $246 \pm 50$  g (range, 188–308 g); and connecting,  $84 \pm 17$  g (range, 71–114 g).

The arterial and venous vasculature was studied in 61 animals. It was observed that 51 pigs (84%) exhibited normal branching from the CT. We found variations in CT anatomy in 10 cases (**Table 3.1, Figure 3.3B**). All pigs exhibited traditional branching at the SMA, sending branches to the CL of the pancreas (inferior pancreaticoduodenal artery). However, one displayed a branch below the SMA that supplied the bowel and another presented additional branches from the SMA toward the colon without variation in the

pancreatic supply. Another pig had a branch to the bowel that came off the SMA before the pancreatic branches. Anatomical findings related to the PPA were diverse and are shown in **Table 3.2 (Figure 3.3B)**. It was found that the PPA most commonly branches from the hepatic artery (54%).

<b>Variations in celiac trunk anatomy</b>	<b>n=10</b>
“Accessory” splenic artery traveling along with the splenic artery	1/10
LGA from the splenic artery	3/10
LGA from the common hepatic artery	2/10
Two LGA, one from the CT and another from splenic artery	2/10
Two LGA from the root of the CT	1/10
No CT. Hepatic and splenic arteries from aorta and LGA from splenic artery	1/10

LGA, left gastric artery; CT, celiac trunk.

**Table 3.1:**  
Variations of the celiac trunk anatomy

<b>Origin of PPA</b>	<b>N</b>	<b>%</b>
Splenic artery	6	21.43
Hepatic artery	15	53.57
Splenic and hepatic artery	6	21.43
Root CT	1	3.57
Total	28	100

CT, celiac trunk.

**Table 3.2:**

Anatomical origin of the posterior pancreatic artery.

After inserting the cannulas into the root of the CT and the SMA, and infusing each one with different colored saline solution, it became apparent that the CT supplied the entire DL and the majority of the SL. The SMA supplied the CL, the bridge, and the inferior aspect of the SL.

The venous outflow occurred through the PV as a result of the merging of the splenic vein and SMV. The splenic vein typically traveled around the superior and posterior aspect of the pancreas and drained the body and the tail (SL). The rest of the pancreas was drained by branches coming from the SMV and the PV. In the cases we examined, the SMV and IMV merged to become the PV in all but one pig; the exception was the IMV draining into the splenic vein, as is traditionally the case in humans (**Figure 3.3B**). The left gastric vein drained into the splenic vein in all studied cases.

The pancreatic ductal network was traced by differential colored saline infusions in 36 pancreata. Fourteen of the 36 pigs (39%) exhibited ductal communication between the CL and the other two lobes. Eleven pigs (31%) exhibited ductal communication only from the SL to the CL with the clamp in position 1 (**Figure 3.4**, type A). In one case (2.8%), the communication only existed from the CL to the SL when the clamp was in either position 2 (**Figure 3.4**, type B). In two cases (5.6%), the colored infusion illustrated that the whole organ could be infused through from both communications, with the clamp in position (type A + B). Eighteen pigs (50%) exhibited no ductal

communication between the SL and CL, but featured communications solely from the DL (type C). We classified a type X (neither type A, B, or C) ductal anatomy in four cases (11.1%). In this category, one pig exhibited no anatomical connection between the SL and CL (bridge atresia); another pig exhibited two separate ducts (one for the DL and SL, and the other for the CL); and in two pigs, the pancreata exhibited minimal ductal communication between the CL and distal SL after the initial infusion and clamping off of the connection between the DL and SL. After clamping off the connection between the DL and CL, the infused colored saline flowed into the DL and the proximal SL.

### **Discussion:**

There is a lack of literature describing the detailed anatomy of the pig pancreas. Comprehensive knowledge of the pig pancreatic anatomy is essential for improvements in pancreas procurement, preservation, and islet isolation protocols [25, 26]. It has been reported that the pancreatic anatomy may vary from donor to donor [27], and several studies [28, 29] have demonstrated the importance of pig strain on islet isolation outcome. Although the use of different breeds was considered, it was decided to focus on Landrace pigs, as this breed is considered to be the most suitable donor for islet isolation [30–32]. Recent literature [33–35] suggests that this breed is desirable for use in xenotransplantation, because isolations yield large numbers of islets and pancreata contain a high islet volume density (3.4%) when compared with other breeds (1%–2%). For this reason, the investigation was focused on understanding the anatomy of the Landrace breed in detail. Krickhahn et al. [36] demonstrated that pancreatic islet size may

be an important parameter influencing islet yield after isolation and this may be dependent on the strain of the pig.

The present study provides more-detailed information about the distribution of the lobes in the pancreas and demonstrates that almost 97% of pancreata exhibited three lobes. One pancreas presented no bridge and another case exhibited a “ring” shaped pancreas. It is important to recognize these kinds of variations if the porcine pancreas is to be used as a source of islets for clinical xenotransplantation. It is critical to understand the functional relationship between pancreatic ducts and drained pancreatic tissue for proper infusion of digestive enzymes and the subsequent isolation of islets. A lack of anatomical knowledge can result in poor or incomplete distension and digestion of the gland. In the 1970s, Calne et al. [37] had described two lobes attached near the duodenum to the body of the pancreas. Other authors [38] divided the pig pancreas into three parts, but named these parts differently as compared with our study: body of the pancreas (*corpus pancreatis*), right lobe of the pancreas (*lobus pancreatis dexter*), and left lobe of the pancreas (*lobus pancreatis sinister*). Kumagai et al. [39] described the pancreas as consisting of the tail, body, head, and the bridge lobes. Gänger et al. [40] described the pig donor operation to obtain duodenopancreaticosplenic specimens for experimental transplantation. They located the orifice of pancreatic duct in the distal tip of the uncinata process, which corresponds to the DL according to our nomenclature. Our data provides a reliable system to classify the pancreatic lobes and the variants in the anatomy eliminating inconsistency in the naming and distribution of the lobes described in the literature; this is



an important point with major implications in the field of pig islet isolation and xenotransplantation.

The present study has demonstrated 10 variations related to the CT anatomy and normal branching coming from the SMA. The distribution and disposition of the PPA were unpredictable (**Table 3.2**). The most common origin of the PPA in the series of Morel et al. [21] was from the splenic artery along the upper border of the pancreas. They found that only two pigs exhibited a major pancreatic artery coming from the hepatic artery, but a small arterial branch from the splenic artery was also observed. Shokouh-Amiri et al. [20] classified the variations in arterial blood supply of the porcine pancreas with three types as they related to the major pancreatic artery (PPA in our study). Nonetheless, they found a PPA arising from the root of the CT. They concluded that segmental pancreatic autotransplantation was technically possible in all animals regardless of the type of arterial supply if the anatomy of the vasculature is known adequately. In contrast, Traverso and McFarlane [23], based on the description of variations in the arterial blood supply to the body and tail of the pancreas, concluded that the pig is unsuitable for pancreatic autotransplantation studies.

Some authors [41] used the tail of the pancreas for various experiments, to minimize complexities associated with variations in the anatomy of the head of the pancreas. To develop a pig model for whole or segmental pancreas transplantation, the arterial anatomy of the pancreas must be precisely mapped out. The blood supply of the pancreas is provided by the celiac and superior mesenteric arteries. The DL of the pancreas receives its blood supply from the superior pancreaticoduodenal artery, which is in all

cases a branch of the gastroduodenal artery. In contrast with this finding, Schröder et al. [42] described the origin of the superior pancreaticoduodenal artery from the splenic artery. The SL is supplied by the splenic artery and the inferior pancreaticoduodenal artery that branches off from the SMA and also supplies the CL and the bridge as well.

After the abdominal aorta was opened through the anterior wall and cannulas were placed into the CT and SMA, the organ was infused with colored saline. It was observed that the color was distributed homogenously throughout the whole gland. The finding demonstrated that CT and SMA cannulation is a suitable technique to sufficiently perfuse the pancreas and could be used in other experiments related to pancreas preservation. In fact, Zhang et al. [43] used the pig model for pancreaticoduodenal transplantation and the donors were perfused by the abdominal aorta without clamping the portal venous outflow. Gabel et al. [44] used the entire pancreas with intact vascular supply to get a graft from a pig donor to transplant in a pig recipient. The organ was perfused by the CT only with no mention of the SMA. These authors described early graft failure caused by concomitant acute pancreatic necrosis, probably followed by vascular complications. To avoid these kinds of complications, it could be useful to dissect the CT and the SMA selectively to ensure good perfusion of the entire pancreas for a vascularized graft for pancreas transplantation, or even if it is used for ITx.

In our study, as well as in others [20, 21], few variations were found in the venous drainage of the pancreas. In only one pig the IMV drained into the splenic vein instead of the SMV.

The impetus to study the pancreatic ductal system was to better understand the ductal branching structure for the purpose of applying the knowledge to the development of enzyme perfusion and pancreatic distention techniques within the context of the pig model. All but one pancreas exhibited only one main pancreatic duct; we found two separate ducts, one for the DL and SL and the other for the CL. There are some discrepancies in the literature. König and Liebich [38] described the dual origin of the pancreas as arising from dorsal and ventral primordial buds, stating that some species have two pancreatic ducts, and the pig is one of them. The accessory pancreatic duct enters the duodenum at the minor duodenal papilla located distal to the major duodenal papilla [22]. On the other hand, Swindle [45] asserted that the pancreas is related to the proximal duodenum with a single pancreatic duct entering the duodenal lumen distal to the common bile duct. Morel et al. [21] in a series of 49 Yorkshire pigs, found one pancreatic duct emerging from the lower right part of the pancreatic head, draining into the second part of the duodenum. Only in one instance of this study, an accessory duct was found draining the CL into the third part of the duodenum. Pitkäranta et al. [46] developed an experimental model of chronic pancreatitis in the pig. They observed a papilla obstruction failure rate of 30%, suggesting the presence of an accessory duct. However, our data do not support these findings.

Even though the pancreatic ductal system and its variability remain the Achilles' heel in islet isolation, the detailed anatomy described here helps to overcome the difficulties associated with complete distention of the gland. Understanding the variable ductal

distribution facilitates simple adaptation of technical distention protocols to make the process more efficient and effective.

In conclusion, the vascular anatomy of the pig pancreas makes it suitable for perfusion through the suprarenal aorta, as is the case in humans. The knowledge of the variations in the anatomy in the vascular supply could help in developing successful new models of whole or segmental pig pancreas preservation and transplantation and islet isolation and transplantation [25, 26]. However, the ductal anatomy can be variable, with branching from the CL being extremely inconsistent. If cannulation is not carefully performed, one portion of the organ may not be properly distended with proteolytic enzymes, resulting in a substantial loss of the islets present in this portion. Careful consideration of all these anatomical findings is likely to facilitate less variable and more economical pig islet isolation for research studies and therapeutic purposes.

## References:

1. Fiorina P, Secchi A. Pancreatic islet cell transplant for treatment of diabetes. *Endocrinol Metab Clin North Am* 2007; 36: 999.
2. Hogan A, Pileggi A, Ricordi C. Transplantation: Current developments and future directions: The future of clinical islet transplantation as a cure for diabetes. *Front Biosci* 2008; 13: 1192.
3. Shapiro AM, Lakey JR, Ryan EA, et al. Islet transplantation in seven patients with type 1 diabetes mellitus using a glucocorticoid-free immunosuppressive regimen. *N Engl J Med* 2000; 343: 230.
4. Hering BJ, Kandaswamy R, Ansite JD, et al. Single-donor, marginal-dose islet transplantation in patients with type 1 diabetes. *JAMA* 2005; 293: 830.
5. Frank A, Deng S, Huang X, et al. Transplantation for type I diabetes: Comparison of vascularized whole-organ pancreas with isolated pancreatic islets. *Ann Surg* 2004; 240:631.
6. Shapiro AM, Ricordi C, Hering BJ, et al. International trial of the Edmonton protocol for islet transplantation. *N Engl J Med* 2006; 355:1318.
7. Froud T, Ricordi C, Baidal DA, et al. Islet transplantation in type 1 diabetes mellitus using cultured islets and steroid-free immunosuppression: Miami experience. *Am J Transplant* 2005; 5: 2037.
8. Keymeulen B, Gillard P, Mathieu C, et al. Correlation between beta cell mass and glycemic control in type 1 diabetic recipients of islet cell graft. *Proc Natl Acad Sci USA* 2006; 103: 17444.
9. Badet L, Benhamou PY, Wojtuszczyzn A, et al. Expectations and strategies regarding islet transplantation: Metabolic data from the GRAGIL 2 trial. *Transplantation* 2007; 84: 89.
10. Kin T, Murdoch TB, Shapiro AM, et al. Estimation of pancreas weight from donor variables. *Cell Transplant* 2006; 15: 181.
11. Matsumoto S, Zhang G, Qualley S, et al. Analysis of donor factors affecting human islet isolation with current isolation protocol. *Transplant Proc* 2004; 36: 1034.
12. Ponte GM, Pileggi A, Messinger S, et al. Toward maximizing the success rates of human islet isolation: Influence of donor and isolation factors. *Cell Transplant* 2007; 16: 595.
13. Sakuma Y, Ricordi C, Miki A, et al. Factors that affect human islet isolation. *Transplant Proc* 2008; 40: 343.
14. Rood PP, Buhler LH, Bottino R, et al. Pig-to-nonhuman primate islet xenotransplantation: A review of current problems. *Cell Transplant* 2006; 15: 89.
15. Hering BJ, Wijkstrom M, Graham ML, et al. Prolonged diabetes reversal after intraportal xenotransplantation of wild-type porcine islets in immunosuppressed nonhuman primates. *Nat Med* 2006; 12: 301.
16. Cardona K, Korbitt GS, Milas Z, et al. Long-term survival of neonatal porcine islets in nonhuman primates by targeting costimulation pathways. *Nat Med* 2006; 12: 304.
17. O'Neil JJ, Stegemann JP, Nicholson DT, et al. The isolation and function of porcine islets from market weight pigs. *Cell Transplant* 2001; 10:235.
18. Mellert J, Hering BJ, Liu X, et al. Critical islet mass for successful porcine islet autotransplantation. *J Mol Med* 1999; 77: 126.

19. Jensen SL, Ku"hl C, Nielsen OV, et al. Isolation and perfusion of the porcine pancreas. *Scand J Gastroenterol Suppl* 1976; 37: 57.
20. Shokouh-Amiri MH, Rahimi-Saber S, Andersen HO. Segmental pancreatic autotransplantation in the pig. *Transplantation* 1989; 47: 42.
21. Morel P, Kaufmann DB, Matas A, et al. Total pancreatectomy in the pig for islet transplantation. Technical alternatives. *Transplantation* 1991; 52: 11.
22. Skjennald A. Anatomy of the liver and pancreas in the domestic swine, with special reference to vascular structures. *Scand J Gastroenterol* 1982; 17: 16.
23. Traverso LW, MacFarlane S. Pancreas autotransplantation: Unsuitability of the swine as a model. *Transplantation* 1987; 44: 450.
24. Turegano-Fuentes F, Garcia-Mene"ndez C, Larrad-Jime"nez A, et al. The feasibility of porcine pancreas autotransplantation—A case for controversy. *Transplantation* 1990; 49: 1028.
25. Scott WE III, Matsumoto S, Tanaka T, et al. Real-time noninvasive assessment of pancreatic ATP levels during cold preservation. *Transplant Proc* 2008; 40: 403.
26. Taylor MJ, Baicu S, Leman B, et al. Twenty-four hour hypothermic machine perfusion preservation of porcine pancreas facilitates processing for islet isolation. *Transplant Proc* 2008; 40: 480.
27. Sabat M, Godlewska E, Kinasiewicz J, et al. Assessment of some porcine strains as donors of islets of Langerhans. *Transplant Proc* 2003; 35:2343.
28. Dufrane D, D'hoore W, Goebbels RM, et al. Parameters favouring successful adult pig islet isolations for xenotransplantation in pig-toprimate models. *Xenotransplantation* 2006; 13: 204.
29. Toso C, Brandhorst D, Oberholzer J, et al. Isolation of adult porcine islets of Langerhans. *Cell Transplant* 2000; 9: 297.
30. Ricordi C, Socci C, Davalli AM, et al. Isolation of the elusive pig islet. *Surgery* 1990; 107: 688.
31. Socci C, Ricordi C, Davalli AM, et al. Selection of donors significantly improves pig islet isolation yield. *Horm Metab Res Suppl* 1990; 25: 32.
32. Kim JH, Kim HI, Lee KW, et al. Influence of strain and age differences on the yields of porcine islet isolation: Extremely high islet yields from SPF CMS miniature pigs. *Xenotransplantation* 2007; 14: 60.
33. Prabhakaran S, Hering BJ. What strain of pig should be used? *Xenotransplantation* 2008; 15: 83.
34. Kirchof N, Hering BJ, Geiss V, et al. Evidence for breed-dependent differences in porcine islets of Langerhans. *Transplant Proc* 1994; 26: 616.
35. Ulrichs K, Bosse M, Heiser A, et al. Histomorphological characteristics of the porcine pancreas as a basis for the isolation of islets of Langerhans. *Xenotransplantation* 1995; 2: 176.
36. Krickhahn M, Bu"bler C, Meyer T, et al. The morphology of islets within the porcine donor pancreas determines the isolation result: Successful isolation of pancreatic islets can now be achieved from young market pigs. *Cell Transplant* 2002; 11: 827.
37. Calne RY, Sells RA, Marshall VC, et al. Multiple organ grafts in the pig. Techniques and results of pancreatic, hepatic, cardiac, and renal allografts. *Br J Surg* 1972; 59: 969.
38. K"onig HE, Liebich H-G. *Veterinary anatomy of domestic mammals, textbook and colour atlas* [ed. 3]. Schattauer, Stuttgart 2004.

39. Kumagai N, O'Neil JJ, Barth RN, et al. Vascularized islet-cell transplantation in miniature swine. I. Preparation of vascularized islet kidneys. *Transplantation* 2002; 74: 1223.
40. Gänger KH, Mettler D, Höflin F, et al. Experimental pancreaticosplenic composite transplantation in the pig. Operative technique and assessment of graft function. *Eur Surg Res* 1987; 19: 323.
41. Shokouh-Amiri MH, Rahimi-Saber S, Andersen HO, et al. Pancreas autotransplantation in pig with systemic or portal venous drainage. Effect on the endocrine pancreatic function after transplantation. *Transplantation* 1996; 61: 1004.
42. Schröder T, Rämö OJ, Joffe SN. Laser pancreatectomy. A comparison between dog and pig. *Res Exp Med (Berl)* 1988; 188: 227.
43. Zhang ZD, Han FH, Meng LX. Establishment of a pig model with enteric and portal venous drainage of pancreatoduodenal transplantation. *World J Gastroenterol* 2005; 11: 5475.
44. Gäbel H, Brynger H, Heding L, et al. Pancreas transplantation in streptozotocin-diabetic juvenile pigs. Evaluation of function among duct-ligated, duct-occluded, and nonligated allografts. *Transplantation* 1983; 36: 609.
45. Swindle M. Technical Bulletin. Comparative anatomy of the pig. Available at: [www.sinclairresearch.com](http://www.sinclairresearch.com).
46. Pitkäranta P, Kivisaari L, Nordling S, et al. Experimental chronic pancreatitis in the pig. *Scand J Gastroenterol* 1989; 24: 987.

## **Chapter 4: Characterization and Improvement of Methods for Porcine Pancreas Procurement**

### **Considerations for persufflation:**

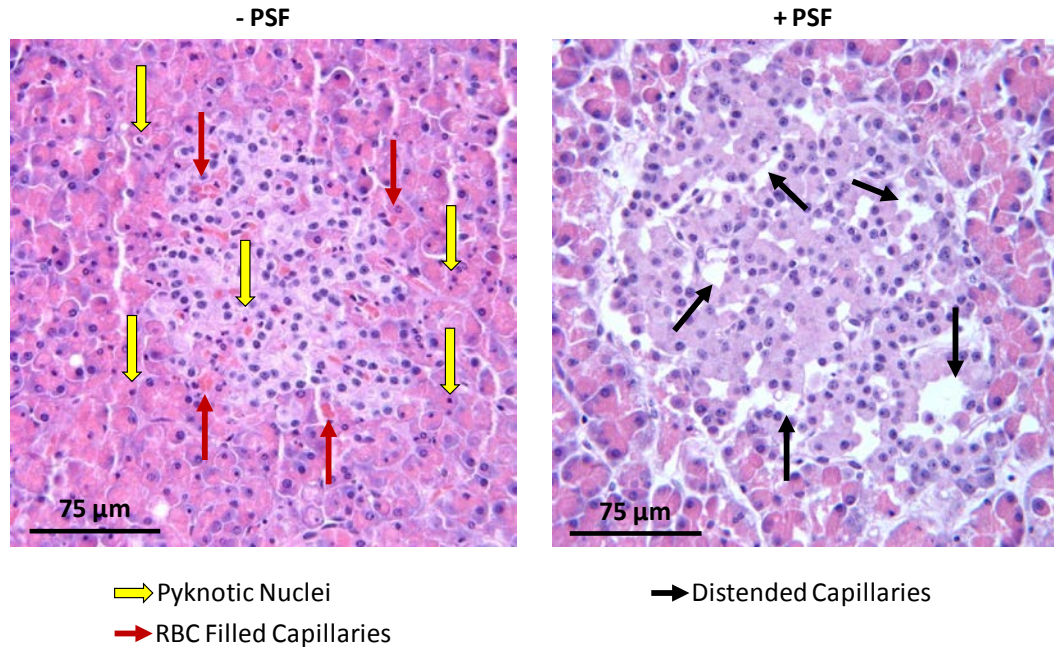
Traditionally the porcine pancreas is procured by trimming along the surface with cooling by crushed ice and/or chilled irrigation. Armed with the anatomical knowledge of the previous study we needed to devise a method of porcine pancreas procurement which would preserve the vasculature required to supply the pancreas with oxygen during persufflation. This is done as follows:

The pig is sacrificed and bled out. An en bloc viscerectomy is performed and the aorta is isolated and longitudinally cut to expose the celiac trunk (CT) and superior mesenteric artery (SMA). All branches not supplying the pancreas; such as the hepatic artery, left gastric artery, and distal-splenic artery are tied off. The portal vein is opened to provide a route for drainage and pancreas is freed from its attachments.

Initially we tried to supply gas via the aorta alone and found that if this is done, the many lumbar arteries present in the pig would have to be tied off. It is therefore more efficient in this model to directly cannulate the CT and SMA. Another side benefit of this is that lower pressures were required to drive gas flow through the pancreas. This may be due to the extreme circumferential flexibility of the aorta, causing it to inflate before gas would pass further into the vasculature.



Initial studies quickly demonstrated the need for an arterial flush to drive blood out of the pancreas prior to persufflation. If this is not done, extremely high pressures (>100 mmHg) were required to generate any flow. We began by flushing the organ out in 1 L increments and found that 3-5 L were needed to produce a clear effusate from the portal vein; indicative of having purged the organ of blood. This enabled us to generate flow at dramatically lower pressures; however initial histological analysis showed that the pancreas was filled with patchy regions of blood. This prevented gas flow to these regions and histological analysis showed that these regions had significantly more autolysis present than the successfully persufflated regions [1]. Some representative sections of persufflated and non-persufflated regions of the same organ are shown in **Figure 4.1** on the next page. The presence of this blood was determined to be due to clotting prior to the flushing of the vasculature. In order to consistently avoid this and persufflate the entire organ, the pigs are now heparinized (100,000 units per pig) at least 5 min before sacrifice.



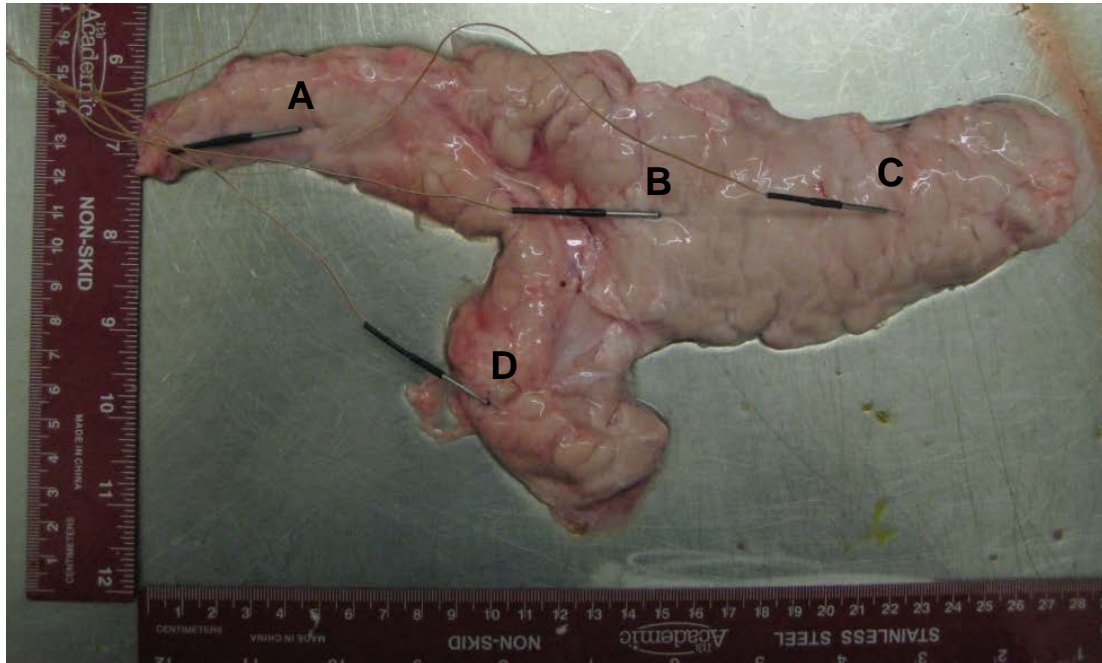
**Figure 4.1:**

Representative biopsies from regions with persufflation (PSF; right) and without PSF (left) from the same organ. A lack of PSF was determined based on the presence of red blood cells (RBC) in the tissue (red arrows). These regions exhibited pyknotic nuclei (yellow arrows) a marker for the later stages of cell death and significantly greater amounts of autolytic damage. In contrast to the RBC's in the non-persufflated regions, the persufflated tissue exhibited distended capillaries (black arrows) throughout the tissue.

## Considerations for organ health

In addition to making persufflation possible, the addition of a vascular flush during procurement presents the possibility for improving the rate of cooling during procurement. While warm ischemia is defined as: the time from cardiac arrest until the beginning of organ cooling; regardless of the cooling technique, the temperature of an organ does not immediately and uniformly cool to  $<10^{\circ}\text{C}$  as soon as cooling begins. Since even brief exposures to warm ischemic conditions can cause damage to pancreatic tissues (with complete disintegration in as little as 45 min), it is important to rapidly and uniformly cool the pancreas. It is with this in mind that the impact of vascular and ductal flushing has on pancreatic core temperature during procurement was investigated.

4 methods of procurement were investigated for porcine pancreas procurement: 1) the traditional method with surface cooling alone, 2) the traditional method with surface cooling and a 60 cc chilled ductal infusion; 3) preserving the vasculature with surface cooling and a 5 L vascular flush; 4) preserving the vasculature with surface cooling, a 60 cc chilled ductal infusion, and a 5 L vascular flush. An initial study comparing all four techniques was performed by inserting temperature probes into the core at 4 distinct locations of the pancreas as shown in **Figure 4.2** and measured values were averaged.

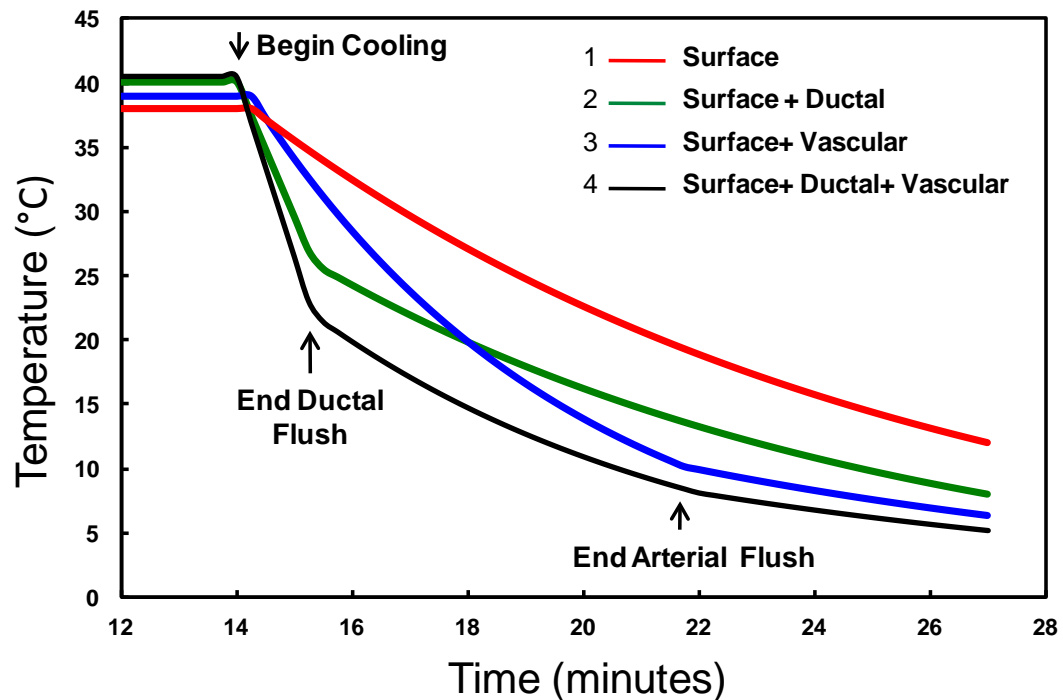


**Figure 4.2:**

Example of temperature probe location and placement. Probes were placed into each organ at 4 locations corresponding to: (A) the duodenal lobe, (B) the mid-splenic lobe, (C) the distal splenic lobe, and (D) the connecting lobe. Probes were inserted into the core at each location prior to the start of cooling and monitored throughout the duration of cooling.

### Initial temperature study:

An initial study was performed comparing all 4 methods of procurement. During this study, we had trouble consistently keeping the probes in the core during the procurement process. Additionally, measurements were only collected until the pancreas was below 20 °C. In spite of this we were able to see characteristic trends in temperature profiles for each of the groups (**Figure 4.3**)



**Figure 4.3:**

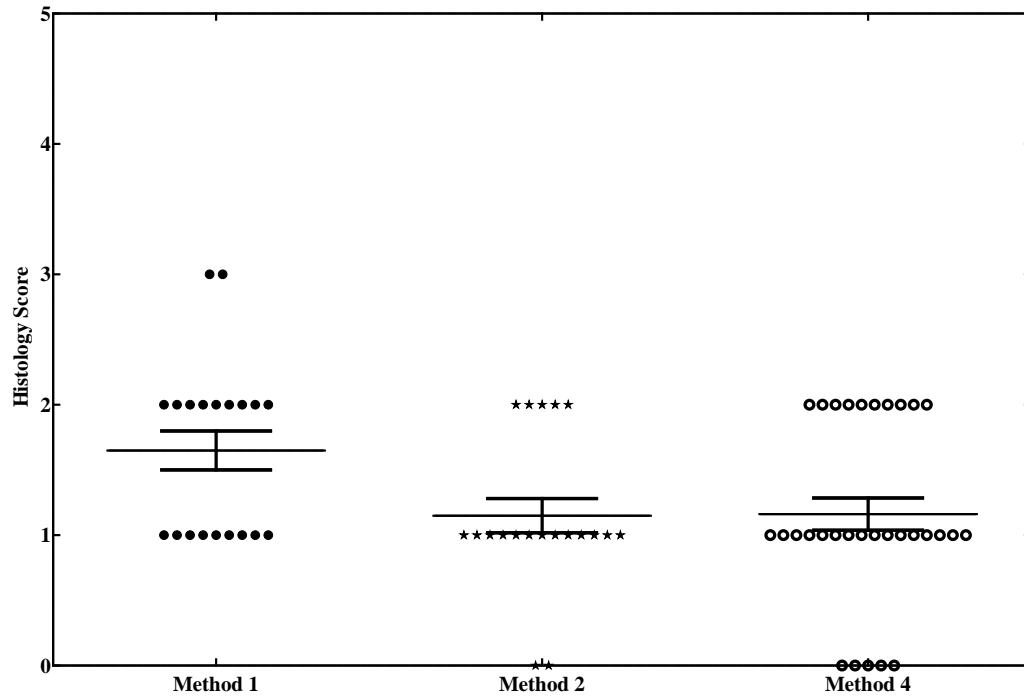
typical temperature profiles associated with each of the 4 procurement methods investigated: 1) Surface cooling alone; 2) Surface cooling with a 60 cc ductal infusion; 3) surface cooling with a 5 L vascular flush; 4) Surface cooling with a 60 cc ductal flush and a 5 L vascular flush.

The profiles observed seem to agree with many of the characteristics predicted of each method at the beginning of the study. Condition 1 was the slowest with only a gradual cooling consistent with diffusion alone. Conditions 2 and 3 demonstrate mixed results with condition 2 providing better initial results due to the bolus infusion however it is overtaken after several minutes by condition 3 due to the consistent heat removal by vascular flush. Condition 4 cooled the best and due to the ease with which all 3 methods of cooling can be combined; it was deemed the best method for rapid cooling during procurement.

## **Histology study:**

Due to the exciting implications of our initial study comparing the 4 methods of procurement, a follow-up study to investigate these methods improvements to histology was pursued. Biopsies of pig pancreas core were obtained and immediately fixed from the 3 lobes of pancreata exposed to procurement methods 1, 2 and 4. Group 3 was excluded as it seemed that if we are to perform a vascular flush we should also perform a ductal infusion due to the ease of performance and the associated initial temperature drop. Paraffin sections were evaluated after hematoxylin and eosin (H&E) staining and insulin immunohistochemistry and systematically scored for necrosis/autolysis by a histologist, according to the following criteria: score 0= none,  $1 \leq 10\%$ ,  $2 = 11-25\%$ ,  $3 = 26-50\%$ ,  $4 = 50-75\%$ ,  $5 \geq 76\%$ . Biopsies from group 1 demonstrated moderate necrosis/autolysis, group 2 mild necrosis/autolysis and group 4 minimal necrosis/autolysis. Scores were compared between groups with a Kruskal-Wallis test yielding a P-value of 0.0414 indicating that one or more groups are statistically different from the others. To further investigate these differences each of the 3 pairs of groups investigated were compared using the Wilcoxon/ Mann-Whitney rank sum test. Groups 1 and 2 were significantly different ( $P = 0.0254$  two-tailed,  $N_1 = 20$ ,  $N_2 = 20$ ,  $U = 126.0$ ) with group 2 demonstrating better histology scores. Groups 1 and 4 were significantly different ( $P = 0.0299$  two-tailed,  $N_1 = 20$ ,  $N_2 = 31$ ,  $U = 207.0$ ) with group 4 demonstrating better histology scores. When Groups 2 and 4 were compared, no statistical differences were observed ( $P = 0.9049$  two-tailed,  $N_1 = 20$ ,  $N_2 = 31$ ,  $U = 304.0$ ). A graph representing the

histology scores with characteristic means and standard errors is included in **Figure 4.4** below.



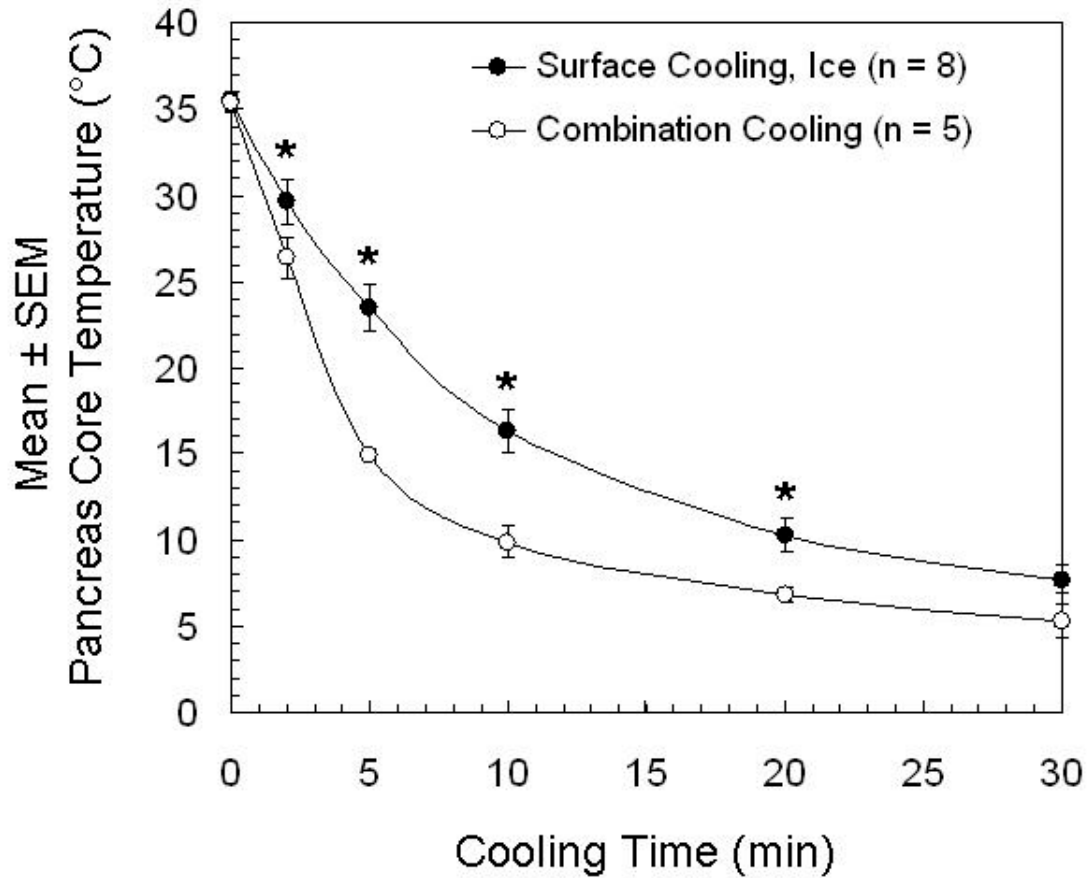
**Figure 4.4:**

Plot of histology scores for biopsies collected from pancreata procured using method 1, surface cooling alone, method 2, surface cooling plus a ductal infusion, or method 4, surface cooling plus a ductal infusion and a vascular flush. Means and standard errors for each group are also presented.



## **Second temperature study:**

A follow-up study was pursued to determine if the observed temperature profile differences between methods could be statistically quantified and to see if organ size had any bearing on cooling between methods 1 and 4. To ensure proper data collection, probes were carefully checked throughout the procurement process to ensure that they did not move. In addition, all organs were monitored for several minutes prior to the start of procurement to obtain consistent baseline values and temperatures were monitored for at least 30 min to ensure that a proper temperature profile could be obtained. Initially groups of 5 pigs were assigned to each method; however after analysis, the size ranges did not match up between groups and so an additional 3 pancreata were investigated for group 1 to try and expand the range. This was done as we have to assign the method of procurement prior to being able to assess pancreas size. We initially thought that the bigger the pigs size the bigger the pancreas would be. This ended up not necessarily being the case as a wide variance was observed in pancreas weight for large adult pigs and due to financial constraints we settled on assessing the organs presented here. The mean temperatures observed are plotted with time in **Figure 4.4** on the next page. It is on note that when method 4 ‘the combination’ method was compared with method 1, surface cooling alone, by a student’s t-test method 4 was statistically significantly better throughout procurement until both methods converged at 30 min. It seemed that method 4 was able to cool pancreata to any given temperature in half the time it took method 1 to achieve the same temperature.

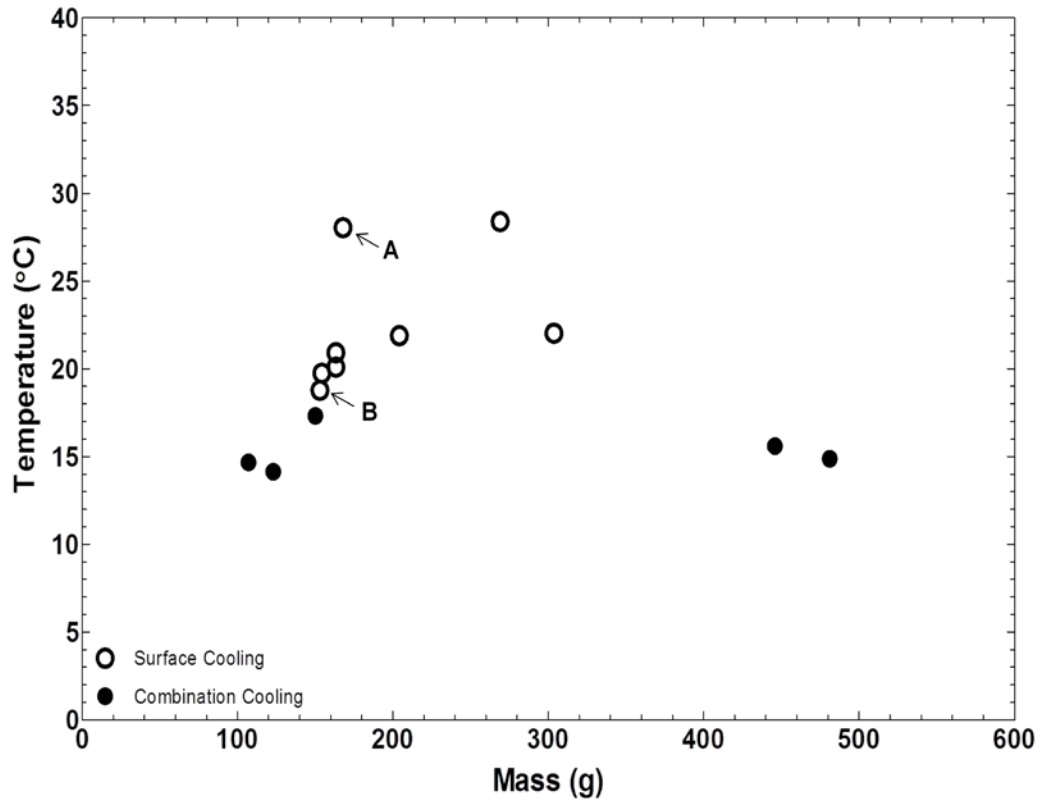


**Figure 4.5:**

Average pancreatic core temperatures for surface cooling and combination cooling. The combination method of cooling resulted in statistically significant (\*,  $P < 0.05$ ) reductions in pancreatic core temperatures at 2, 5, 10, and 20 minutes of cooling.

In addition to overall cooling improvements demonstrated with method 4, we wanted to see if it could provide a more homogeneous cooling across a range of pancreas sizes encountered. This way we would know if it provides a benefit for all pancreata or just those from older donors. Each pancreas was therefore weighed and characteristic measurements collected from each lobe. When mean temperatures were plotted against mass 5 min after the start of procurement (**Figure 4.6**) we found that method 4 seemed to

present a consistent cooling profile regardless of mass with even the largest organs cooling faster than any organs procured with method 1.

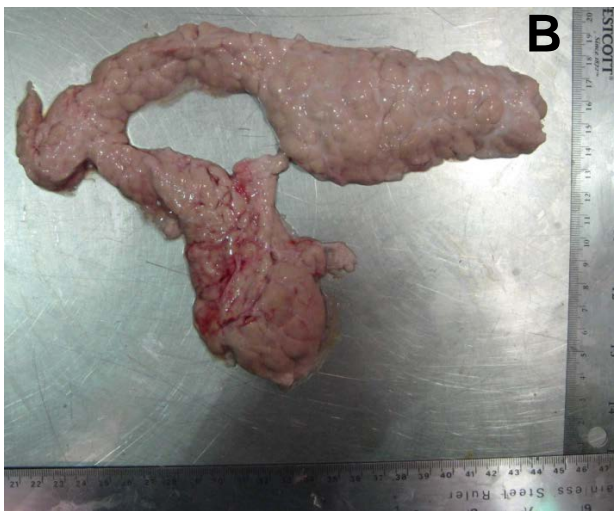
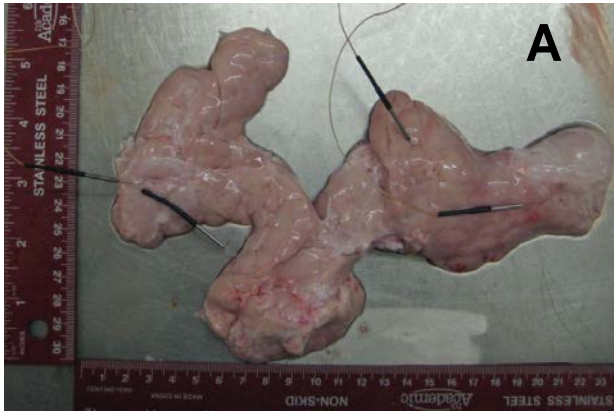


**Figure 4.6:**

Mean pancreatic core temperature following 5 min of cooling by either surface cooling alone (1), or surface cooling plus a ductal infusion and vascular flush (4) vs the trimmed pancreas mass. A and B correspond to the pancreata presented in **Figure 4.7** below.

Organs procured with method 1 seemed to vary much more even within a given range of mass demonstrating the variability of this method even when extreme care is taken to consistently cool the entirety of the surface throughout procurement; an unrealistic measure taken for this study. When characteristic dimensions were compared with

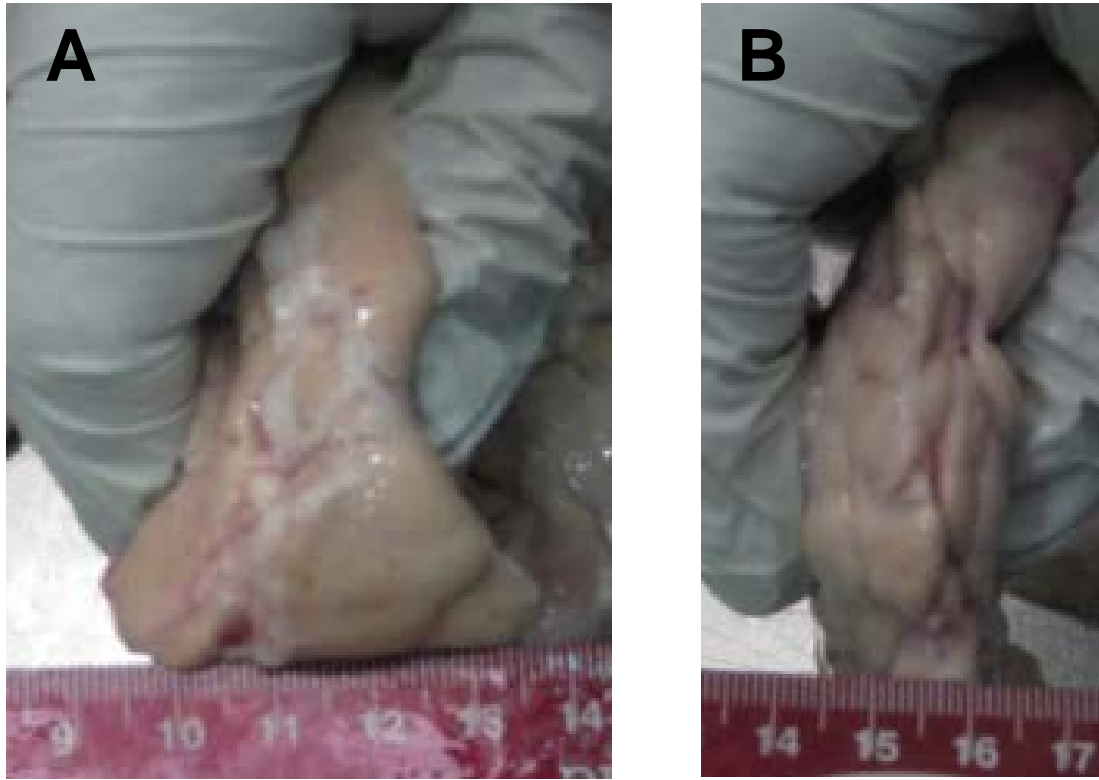
temperature drop, characteristic dimensions and geometries varied substantially (**Figure 4.7**). These differences seemed to impact the rate of cooling as demonstrated by looking at pancreas A and pancreas B in **Figure 4.6**. In addition to these pig to pig variations, substantial differences in characteristic thickness were observed within the same pancreas and even the same lobe (**Figure 4.8**).



**Figure 4.7:**

Images of 2 porcine pancreata as well as characteristic dimensions measured from each. Even though both organs had similar masses (A: 168 g, B: 153 g), their characteristic dimensions varied, in some cases dramatically. This resulted in variability of the rate of cooling for surface cooled organs seen in Figure 4.6 above.

Dimension (cm)	A	B
Connecting L	7.59	12.5
Connecting W	5.99	5.68
Connecting D	3.27	2.35
Splenic L	13.3	15.6
Splenic Distal W	3.91	4.87
Splenic Proximal W	8.24	5.99
Splenic D	2.94	1.7



**Figure 4.8:**

Images from the same pancreas of the thickness of (A) the connecting lobe and (B) the splenic lobe. Thickness may vary dramatically from lobe to lobe within the same organ which may result in uneven cooling between lobes cooled with surface cooling. Furthermore, a dramatic variation in thickness can be observed even within the same lobe (A), exemplifying the variability that may be present within individual organs.

## **Conclusions:**

Even brief exposure to warm ischemia can cause significant damage to porcine pancreatic tissue. Exposure to warm ischemic conditions does not immediately stop upon the start of pancreas cooling measures. It is therefore important to employ methods which can uniformly, rapidly and repeatedly cool pancreatic tissue during procurement. Based on the results presented above, it was concluded that group 4 was the best method for pig pancreas procurement. This is due to its ability to rapidly cool organs regardless of size and geometry and the associated histological improvements observed. Procurement can also play a major role in the options available for subsequent preservation and should be considered carefully. Due to these studies and the robustness of method 4, the University of Minnesota has now changed its porcine procurement protocol to a variant of method 4 with variants due to pig size and age present. The use of this method has led to improved yields and consistency in isolation outcomes since its employment [2].

## References:

1. Scott WE, 3rd, O'Brien TD, Ferrer-Fabrega J, Avgoustiniatos ES, Weegman BP, Anazawa T et al. Persufflation Improves Pancreas Preservation When Compared With the Two-Layer Method. *Transplant Proc* 2010;42(6):2016-2019.
2. Anazawa T, Balamurugan AN, Papas KK, Avgoustiniatos ES, Ferrer J, Matsumoto S et al. Improved Method of Porcine Pancreas Procurement With Arterial Flush and Ductal Injection Enhances Islet Isolation Outcome. *Transplant Proc* 2010;42(6):2032-2035.

## **Chapter 5: Oxygen Persufflation Improves and Maintains Porcine and Human Pancreatic ATP Assessed by <sup>31</sup>P-NMR Spectroscopy**

Once issues with the maintenance of vascular integrity during procurement were addressed, the use of NMR to assess the impact of persufflation on ATP levels during preservation was able to be investigated. 2 studies were pursued; an initial study in the pig model, and a followup study using locally procured human research grade pancreata. These studies are summarized below:

### **Oxygen Persufflation Increases Pancreatic ATP Levels as Shown by NMR**

An initial study looking at the distribution of gas within the pancreata and the impact of persufflation on maintenance of ATP levels was pursued. This study is summarized in the original manuscript: **WE Scott III, BP Weegman, J Ferrer-Fabrega, SA Stein, T Anazawa, VA Kirchner, MD Rizzari, J Stone, S Matsumoto, BE Hammer, AN Balamurugan, LS Kidder, TM Suszynski, ES Avgoustiniatos, SG Stone, L Tempelman, DER Sutherland, BJ Hering, KK Papas: Pancreas Oxygen Persufflation Increases ATP Levels as Shown by NMR; Transplantation Proceedings, 2010 Jul-Aug;42(6):2011-5.**; included with the permission of the publisher of the journal 'Transplantation Proceedings', Elsevier (Appendix 5).



Transplantation Proceedings, 42, 2011–2015 (2010)

**Title:**

Pancreas Oxygen Persufflation Increases ATP Levels as Shown by Nuclear Magnetic Resonance<sup>4</sup>

**Authors:**

W.E. Scott III, B.P. Weegman, J. Ferrer-Fabrega, S.A. Stein, T. Anazawa, V.A. Kirchner, M.D. Rizzari, J. Stone, S. Matsumoto, B.E. Hammer, A.N. Balamurugan, L.S. Kidder, T.M. Suszynski, E.S. Avgoustiniatos, S.G. Stone, L.A. Tempelman, D.E.R. Sutherland, B.J. Hering, and K.K. Papas

---

<sup>4</sup> Supported by a grant from the National Center for Research Resources (U42 RR016598), National Institutes of Health (NIH), NIH National Institute of Diabetes and Digestive and Kidney Diseases (R43 DK070400), the Schott Foundation, and the Carol Olson Memorial Diabetes Research Fund.

The authors thank Dr T.C. Aasheim, Dr L. Guenther, and Dr T. Tanaka for help with early technique development; P.C. Williams, K. Albeck, and S. Walsch for technical assistance with the manufacturing of MR-compatible preservation containers; B. Perrault for surgical assistance; and Dr K.S. Maynard, D. Dudero, G. Wildey, M.L. Graham, L. Mutch, and H. Nelson for administrative assistance.

Address reprint requests to Klearchos K. Papas, PhD, Schulze Diabetes Institute, University of Minnesota Medical School, Mayo Mail Code 195, 420 Delaware St SE, Minneapolis, MN 55455. E-mail: papas006@umn.edu

From the Department of Surgery (W.E.S., B.P.W., J.F.-F., S.A.S., T.A., V.A.K., M.D.R., S.M., A.N.B., L.S.K., T.M.S., E.S.A., D.E.R.S., B.J.H., K.K.P.), Schulze Diabetes Institute, University of Minnesota, Minneapolis, Minnesota, USA; Department of Surgery (J.S.), University of Minnesota, Minneapolis, Minnesota, USA; and Department of Radiology (B.E.H.), Center for Interdisciplinary Applications in Magnetic Resonance, University of Minnesota, Minneapolis, Minnesota, USA; and Giner Inc. (S.G.S., L.T.), Newton, Massachusetts; and Department of Surgery (M.D.R.), University of Texas Southwestern, Dallas, Texas, USA.

**Background.** Islet transplantation is a promising treatment for type 1 diabetes. Due to a shortage of suitable human pancreata, high cost, and the large dose of islets presently required for long-term diabetes reversal; it is important to maximize viable islet yield. Traditional methods of pancreas preservation have been identified as suboptimal due to insufficient oxygenation. Enhanced oxygen delivery is a key area of improvement. In this paper, we explored improved oxygen delivery by persufflation (PSF), ie, vascular gas perfusion.

**Methods.** Human pancreata were obtained from brain-dead donors. Porcine pancreata were procured by en bloc viscerectomy from heparinized donation after cardiac death donors and were either preserved by either two-layer method (TLM) or PSF. Following procurement, organs were transported to a 1.5 T magnetic resonance (MR) system for <sup>31</sup>P-nuclear magnetic resonance spectroscopy to investigate their bioenergetic status by measuring the ratio of adenosine triphosphate to inorganic phosphate (ATP:P<sub>i</sub>) and for assessing PSF homogeneity by MRI.

**Results.** Human and porcine pancreata can be effectively preserved by PSF. MRI showed that pancreatic tissue was homogeneously filled with gas. TLM can effectively raise ATP:P<sub>i</sub> levels in rat pancreata but not in larger porcine pancreata. ATP:P<sub>i</sub> levels were almost undetectable in porcine organs preserved with TLM. When human or porcine organs were preserved by PSF, ATP:P<sub>i</sub> was elevated to levels similar to those observed in rat pancreata.

**Conclusion.** The methods developed for human and porcine pancreas PSF homogeneously deliver oxygen throughout the organ. This elevates ATP levels during

preservation and may improve islet isolation outcomes while enabling the use of marginal donors, thus expanding the usable donor pool.

**Introduction:**

Islet transplantation is an emerging treatment alternative for type 1 diabetes [1, 2]. Currently, clinical islet allotransplantation is limited by a shortage of suitable donor organs, loss of islets throughout the islet manufacturing and transplantation process, high cost, and the large dose of islets required for long-term diabetes reversal. Islets may be predisposed to death before or during isolation owing to improper handling of the organ during procurement and/or suboptimal cold preservation (CP) during transport. Significant research effort has focused on investigating the efficacy of the 2-layer method (TLM), the present state-of-the art for pancreas preservation [3-8]. In the late 1990s, many centers reported improvements in islet isolation outcome using TLM for CP. These improvements were attributed to an increase in tissue adenosine triphosphate (ATP) attributed to enhanced tissue oxygenation with TLM compared with the previously used CP in University of Wisconsin (UW) solution alone [3-8]. However, recent studies have suggested that TLM is not able to oxygenate large portions of human or porcine pancreata during CP [9, 10]. In addition, several large retrospective analyses have found no significant improvement in isolation outcomes for pancreata stored with TLM compared with pancreata stored in UW solution alone [11-13]. Therefore, it is of great importance to develop novel methods of preservation which can better oxygenate large organs. One such method investigated here is persufflation (PSF), or vascular gas perfusion. PSF has been investigated in the heart, liver, kidney, and small intestine, but until now not reported for pancreas preservation [14-23]. We used  $^{31}\text{P}$ -nuclear magnetic resonance (NMR) spectroscopy, a well-established technique for monitoring the amount of ATP present relative to inorganic phosphate ( $\text{P}_i$ ) in tissues, to assess the efficacy of

preservation of large organs with TLM compared with PSF. The bioenergetic status of pancreata was monitored and these data were compared to data collected from our previous study of murine pancreata [24].  $^{31}\text{P}$ -NMR has been used extensively to study tumor biology, bioenergetics, and the metabolism and health status of organs, such as the heart, brain, kidney, liver, and recently, the pancreas [24-33]. The noninvasive nature of  $^{31}\text{P}$ -NMR and its ability to provide information in real time make it an effective and powerful tool for monitoring the bioenergetic status of pancreata and other tissues during CP.

## **Methods:**

### **Procurement**

**Rat.** Rat pancreata were investigated as detailed by Scott et al [23]. All procedures using laboratory animals were approved by the University of Minnesota IACUC.

**Pig.** Pig pancreata were procured by en bloc viscerectomy from heparinized donation after cardiac death Landrace donors as detailed by Ferrer et al [34]. Organs were then preserved at 4 °C with TLM or by PSF. All procedures using laboratory animals were approved by the University of Minnesota Institutional Animal Care and Use Committee (IACUC).

**Human.** Human pancreata were procured from brain-dead donors. In short, after adequate exposure of the pancreas was obtained through a cruciate abdominal incision, the preliminary dissection was performed with intact donor circulation. Once the donor was fully heparinized, the distal aortic cannula was inserted, and the infusion of the chilled preservation solution was initiated after the encircled supraceliac aorta was cross-clamped. It was left up to the liver team to decide whether portal venous infusion should be performed through cannulation of the inferior mesenteric versus portal vein. The venous system was decompressed via venotomy. The organs remained in situ until the cold infusion was complete. The pancreas was either harvested en bloc with the liver and separated on the back table or removed after the harvest of clinical organs. Research consent was obtained from all donor families before procurement.

### **Preservation**

TLM. Whole pancreata or individual porcine lobes preserved with TLM were preserved as previously described [35]. In brief, pancreata or lobes were suspended halfway between 1 L of cold preservation solution (histidine-tryptophan-ketoglutarate [HTK] solution) and perfluorodecalin that was preoxygenated for 1 hour before preservation by bubbling with 99% oxygen gas. Preservation was performed in specially constructed vessels composed of magnetic resonance (MR)-compatible materials. Persufflation. Pancreata were bathed in HTK solution and pumped with 20 mL/min 40% humidified oxygen gas to both the superior mesenteric artery and either the splenic artery (human) or celiac trunk (pig) using an electrochemical oxygen concentrator (Giner Inc., Newton, MA). After procurement, organs were transported to a 1.5 T magnet for  $^{31}\text{P}$ -NMR

spectroscopy to investigate their bioenergetic status by measuring the ratio of ATP to  $P_i$  (ATP: $P_i$ ). Preservation was performed in specially constructed vessels containing MR-compatible materials.

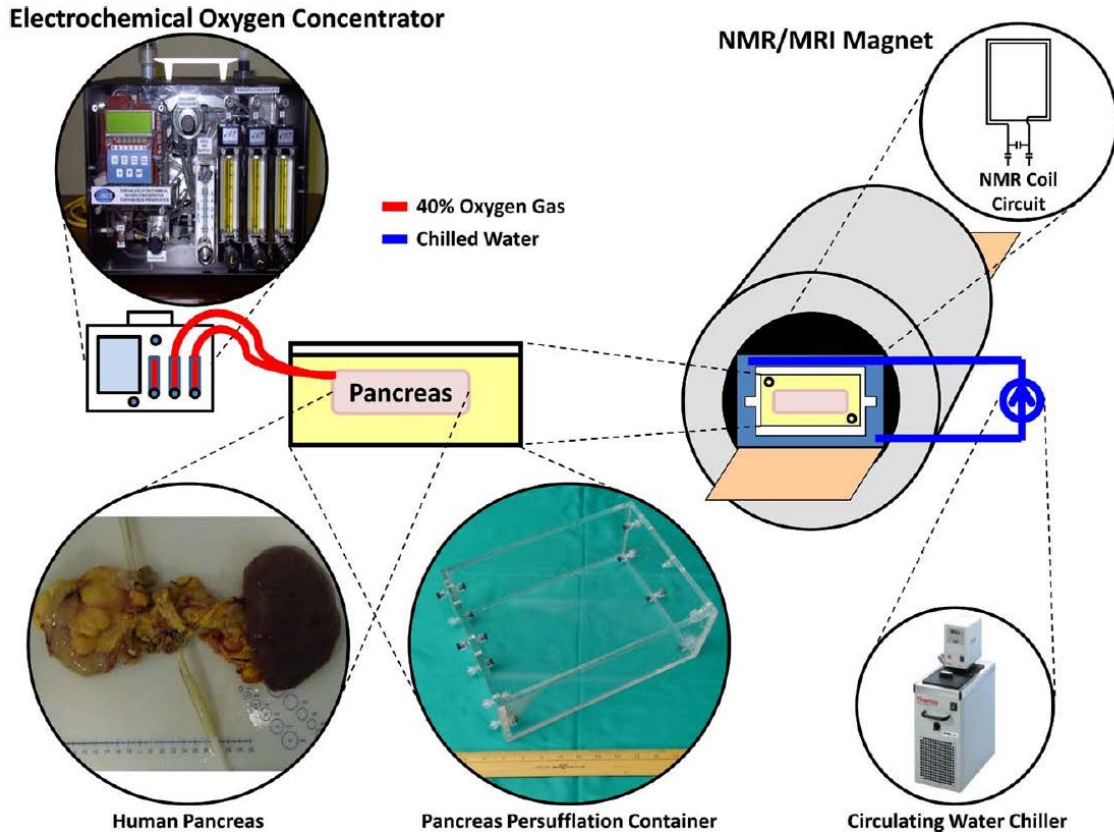
## **MRI**

All MRI was done in a 1.5 T magnet using either a birdcage or surface coil at 63.85 MHz. A  $T_1$ -weighted gradient echo sequence was used to acquire all images. Assessment of the homogeneity of PSF was done by observing the presence of gas in the vasculature by the negative contrast it provides during MRI.

## **$^{31}\text{P}$ -NMR Spectroscopy**

For the pig and human organs, NMR spectroscopy was done in a 1.5 T magnet by placing a surface coil tuned to 25.85 MHz as close to the organ as possible. Rat pancreata were assessed as described by Scott et al.<sup>23</sup> The areas of the  $\alpha$ -,  $\beta$ -, and  $\gamma$ -ATP peaks were compared with the area of the  $P_i$  peak to monitor the bioenergetic status of the organs. A schematic diagram of how organs were placed into the magnet and maintained during preservation is shown in **Figure 5.1**.





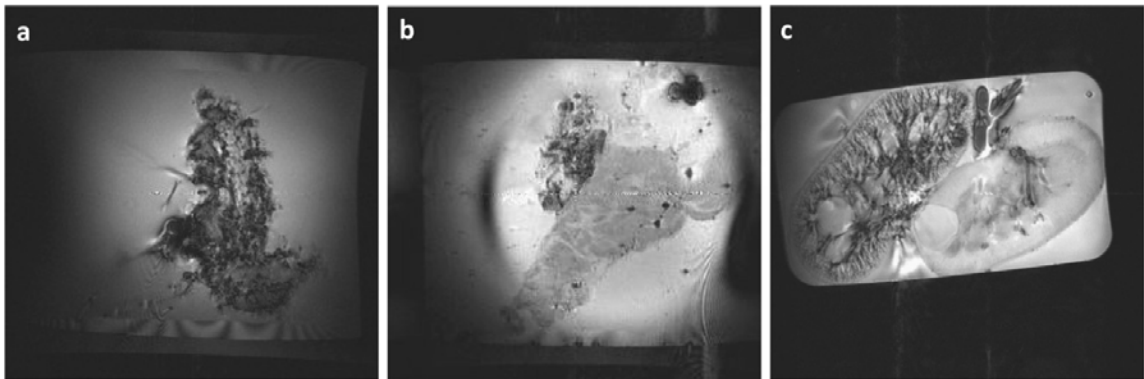
**Figure 5.1:**

Diagram illustrating how the pancreas was placed into the magnet during data acquisition.

**Results:**

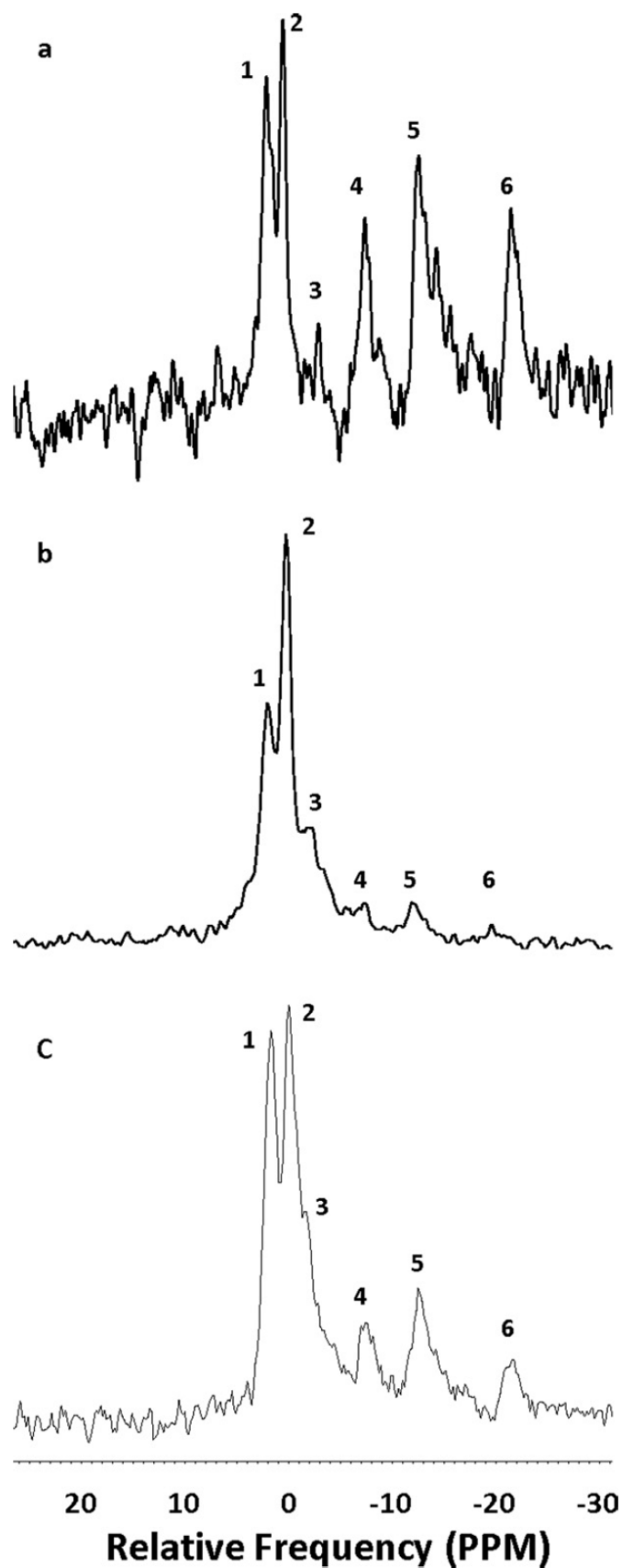
PSF organs typically exhibited the presence of negative contrast (indicating the presence of gas in the vasculature) in 90% of the tissue. Representative images from a PSF pancreas and a pancreas that exhibited significant gas leakage are shown in Figure 5.2. Also shown in Figure 5.2 is a well PSF porcine kidney showing a typical vascular branching structure and a non-PSF kidney that exhibited no negative contrast. As previously reported, rat pancreata exposed to TLM exhibited high levels of ATP: $P_i$ , with TLM superior to other methods of static preservation [24]. When we investigated porcine

pancreata preserved with TLM, however, ATP levels were nearly undetectable (Figure 5.3). ATP levels observed from organs preserved by TLM were indistinguishable from those measured in organs preserved in HTK solution alone. The lack of ATP observed, reflects the inability of TLM to adequately supply the majority of the pancreas with oxygen in larger organs, such as from pigs or humans. However, when we investigated PSF of human pancreata we observed elevated ATP:P<sub>i</sub> levels similar to those observed from the rat model preserved by TLM (Figure 5.3). When PSF was abruptly stopped and human organs were exposed to static preservation alone, ATP:P<sub>i</sub> quickly decreased to undetectable levels similar to those observed from porcine organs preserved by TLM. This confirms that PSF was responsible for the elevated ATP:P<sub>i</sub> observed.



**Figure 5.2:**

Gradient echo MRI of (a) a well persufflated pancreas with gas filling the vasculature indicated by dark regions, typical of what was observed in general; (b) a pancreas with poor persufflation which had a large arterial gas leak; and (c) a well persufflated kidney (left) and a nonpersufflated kidney (right), the persufflated kidney showing typical vascular branching (dark regions).



**Figure 5.3:**

$^{31}\text{P}$ -NMR spectra acquired from (a) a rat pancreas preserved by the two-layer method (TLM); (b) a porcine pancreas preserved by TLM; and (c) a persufflated human pancreas. Peak numbering corresponds to: 1) phosphomonoester; 2) inorganic phosphate; 3) phosphodiester; 4)  $\gamma$ -ATP; 5)  $\alpha$ -ATP; and 6)  $\beta$ -ATP.

**Discussion:**

In this paper we used  $^{31}\text{P}$ -NMR spectroscopy to noninvasively assess the efficacy of different preservation protocols (TLM and PSF) in maintaining ATP levels (a direct reflection of respiration and measure of organ health and viability) in rat, porcine, and human pancreata. Previous investigation demonstrated that, in the rat pancreas model, CP with TLM results in dramatically improved ATP levels [24]. The impact of TLM was investigated in porcine pancreata and compared with a novel method of pancreas preservation, PSF, in the pig and human models. ATP levels were consistently low for all organs preserved by static methods, such as TLM. However, ATP levels from human and porcine pancreata preserved by PSF were consistently higher than those observed from organs exposed to static preservation, approaching levels observed from rat pancreata preserved with TLM alone. This is due to the improved oxygenation the tissue experiences during PSF by providing humidified oxygen directly into the bulk of the solid organ through the extensive native intact vasculature. This delivery method circumvents the problem of limited oxygen diffusion into the core of larger organs (such as human or porcine pancreata) associated with the static methods of preservation. MRI indicated that PSF can actively supply most of the pancreas with gaseous oxygen during cold preservation.

## References:

1. Shapiro AM, Lakey JR, Ryan EA, et al: Islet transplantation in seven patients with type 1 diabetes mellitus using a glucocorticoid- free immunosuppressive regimen. *N Engl J Med* 343:289, 2000
2. Shapiro AM, Ricordi C, Hering B: Edmonton's islet success has indeed been replicated elsewhere. *Lancet* 362(9391):1242, 2003
3. Hiraoka K, Kuroda Y, Suzuki Y, et al: Outcomes in clinical pancreas transplantation with the two-layer cold storage method versus simple storage in University of Wisconsin solution. *Transplant Proc* 34:2688, 2002
4. Tsujimura T, Kuroda Y, Avila JG, et al: Influence of pancreas preservation on human islet isolation outcomes: impact of the two-layer method. *Transplantation* 78:96, 2004
5. Matsumoto S, Zhang G, Qualley S, et al: The effect of two-layer (University of Wisconsin solution/perfluorochemical) preservation method on clinical grade pancreata prior to islet isolation and transplantation. *Transplant Proc* 36:1037, 2004
6. Tsujimura T, Kuroda Y, Avila JG, et al: Resuscitation of the ischemically damaged human pancreas by the two-layer method prior to islet isolation. *Transplant Proc* 35:2461, 2003
7. Ricordi C, Fraker C, Szust J, et al: Improved human islet isolation outcome from marginal donors following addition of oxygenated perfluorocarbon to the cold-storage solution. *Transplantation* 75:1524, 2003
8. Matsumoto S, Kuroda Y: Perfluorocarbon for organ preservation before transplantation. *Transplantation* 74:1804, 2002
9. Avgoustiniatos ES, Hering BJ, Papas KK: The rat pancreas is not an appropriate model for testing the preservation of the human pancreas with the two-layer method. *Transplantation* 81:1471, 2006
10. Papas KK, Hering BJ, Guenther L, et al: Pancreas oxygenation is limited during preservation with the two-layer method. *Transplant Proc* 38:3501, 2005
11. Kin T, Mirbolooki M, Salehi P, et al: Islet isolation and transplantation outcomes of pancreas preserved with University of Wisconsin solution versus two-layer method using preoxygenated perfluorocarbon. *Transplantation* 82:1286, 2006
12. Caballero-Corblan J, Eich T, Foss A, et al: No beneficial effect of the two layer method (PFCUW) compared with transportation in UW alone on the outcome of human islet isolation and transplantation: a report on 214 human pancreases. *Am J Transplant* 2 (6 suppl 2):340, 2006
13. Caballero-Corblan J, Eich T, Lundgren T, et al: No beneficial effect of two-layer storage compared with UW-storage on human islet isolation and transplantation. *Transplantation* 84:864, 2007
14. Kuhn-Regnier F, Fischer JH, Jeschkeit S, et al: Coronary oxygen persufflation combined with HTK cardioplegia prolongs the preservation time in heart transplantation. *Eur J Cardiothorac Surg* 17:71, 2000
15. Fischer JH, Kuhn-Régnier F, Jeschkeit S, et al: Excellent recovery after prolonged heart storage by preservation with coronary oxygen persufflation: orthotopic pig heart transplantations after 14-hr storage. *Transplantation* 66:1450, 1998

16. Yotsumoto G, Jeschkeit-Schubbert S, Funcke C, et al: Total recovery of heart grafts of non-heart-beating donors after 3 hours of hypothermic coronary oxygen persufflation preservation in an orthotopic pig transplantation model. *Transplantation* 75:750, 2003
17. Tolba RH, Schildberg FA, Schnurr C, et al: Reduced liver apoptosis after venous systemic oxygen persufflation in non-heartbeating donors. *J Invest Surg* 19:219, 2006
18. Saad S, Minor T, Kötting M, et al: Extension of ischemic tolerance of porcine livers by cold preservation including postconditioning with gaseous oxygen. *Transplantation* 71:498, 2001
19. Minor T, Akbar S, Tolba R, Dombrowski F: Cold preservation of fatty liver grafts: prevention of functional and ultrastructural impairments by venous oxygen persufflation. *J Hepatol* 32:105, 2000
20. Rolles K, Foreman J, Pegg DE: A pilot clinical study of retrograde oxygen persufflation in renal preservation. *Transplantation* 48:339, 1989
21. Rolles K, Foreman J, Pegg DE: Preservation of ischemically injured canine kidneys by retrograde oxygen persufflation. *Transplantation* 38:102, 1984
22. Treckman JW, Paul A, Saad S, et al: Primary organ function of warm ischaemically damaged porcine kidneys after retrograde oxygen persufflation. *Nephrol Dial Transplant* 21:1803, 2006
23. Minor T, Klauke H, Isselhard W: Improved preservation of the small bowel by luminal gas oxygenation: energetic status during ischemia and functional integrity upon reperfusion. *Transplant Proc* 29:2994, 1997
24. Scott III WE, Matsumoto S, Tanaka T, et al: Real-time noninvasive assessment of pancreatic ATP levels during cold preservation. *Transplant Proc* 40:403, 2008
25. Arias-Mendoza F, Brown TR: In vivo measurement of phosphorous markers of disease. *Dis Markers* 19:49, 2003–2004
26. Dobbins RL, Malloy CR: Measuring in-vivo metabolism using nuclear magnetic resonance. *Curr Opin Clin Nutr Metab Care* 6:501, 2003
27. Horn M: Cardiac magnetic resonance spectroscopy: a window for studying physiology. *Methods Mol Med* 124:225, 2006
28. Barnard ML, Changani KK, Taylor-Robinson SD: The role of magnetic resonance spectroscopy in the assessment of kidney viability. *Scand J Urol Nephrol* 31:487, 1997
29. Davidson BR, Barnard ML, Changani KK, Taylor-Robinson SD: Liver transplantation: current and potential applications of magnetic resonance spectroscopy. *Liver Transpl Surg* 3:481, 1997
30. Khan SA, Cox IJ, Hamilton G, et al: In vivo and in vitro nuclear magnetic resonance spectroscopy as a tool for investigating hepatobiliary disease: a review of H and P MRS applications. *Liver Int* 25:273, 2005
31. Gillies RJ, Morse DL: In vivo magnetic resonance spectroscopy in cancer. *Annu Rev Biomed Eng* 7:287, 2005
32. Yoshikawa T, Suzuki Y, Kanashiro M, et al: Objective and rapid assessment of pancreas graft viability using <sup>31</sup>P-nuclear magnetic resonance spectroscopy combined with two-layer cold storage method. *Transplantation* 78:78, 2004
33. Siech M, Sotak CH, Letko G, Davis MA: A method for in vivo assessment of reversible rat pancreatic ischemia using <sup>31</sup>P NMR spectroscopy at 2 Tesla. *Magn Reson Imaging* 13:463, 1995

34. Ferrer J, Scott III WE, Weegman BP, et al: Pig pancreas anatomy: implications for pancreas procurement, preservation, and islet isolation. *Transplantation* 86:1503, 2008
35. Kuroda Y, Kawamura T, Suzuki Y, et al: A new, simple method for cold storage of the pancreas using perfluorochemical. *Transplantation* 46:457, 1988

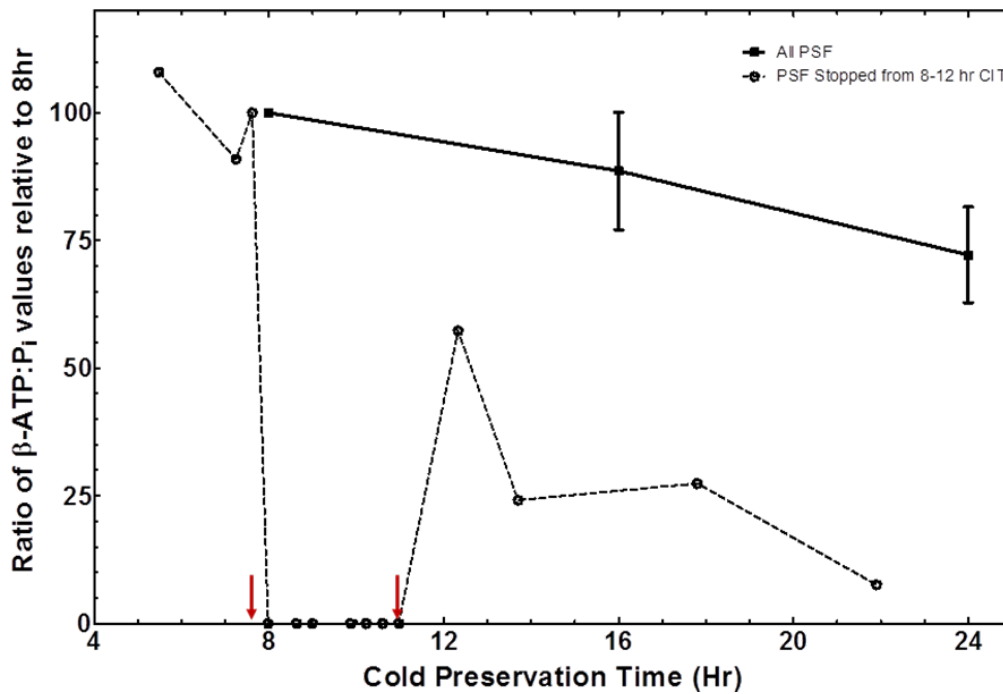
## **Oxygen Persufflation Maintains Pancreatic ATP Levels as Shown by NMR**

Following up on the exciting findings from the initial pig study, a follow-up study was pursued with locally procured human pancreata. 8 human pancreata were investigated for this study. All MRI was performed as before at 1.5 T using either a birdcage or surface coil tuned to 63.785 MHz. T1 weighted gradient echo images were obtained for 2 mm slices at the beginning and end of each study. Pancreata were deemed to be sufficiently persufflating if > 85 % of the overall tissue exhibited negative contrast due to the presence of gas. This was typically achieved following the initial cannulation and leak testing but on occasion further leak testing needed to be performed. In one case a leak near the portal vein exit went undetected and a majority of the tissue was un-persufflated. The ability to confirm the extent and homogeneity of PSF proved invaluable during technique development by giving us a quick snapshot of what was happening inside the pancreas.

Following acquisition of MRI;  $^{31}\text{P}$  NMR spectra were obtained at 1.5 T as described in Appendix 5d. Spectra were at 8, 16 and 24 hours of cold ischemia time. The areas of  $\beta$ -ATP and inorganic phosphate peaks were fitted with the ACD 1D-NMR processing software and  $\beta$ -ATP: $\text{P}_i$  values were calculated. Values were then normalized to the 8 hour time point (typically the first spectrum collected) and  $\beta$ -ATP: $\text{P}_i$  values were followed with time to see how well PSF could maintain ATP for extended preservation times (Figure 5.4). ATP levels were maintained throughout preservation with only a nominal drop (27.81 %) observed from 8 to 24 hours. For one pancreas, PSF was stopped



following acquisition of a baseline 8 hour spectrum and ATP values immediately plummeted to undetectable levels (Figure 5.4). When PSF was re-started 3 hours later, a partial restoration of ATP was observed, but not to levels expected for continuously persufflated organs (Figure 5.4).

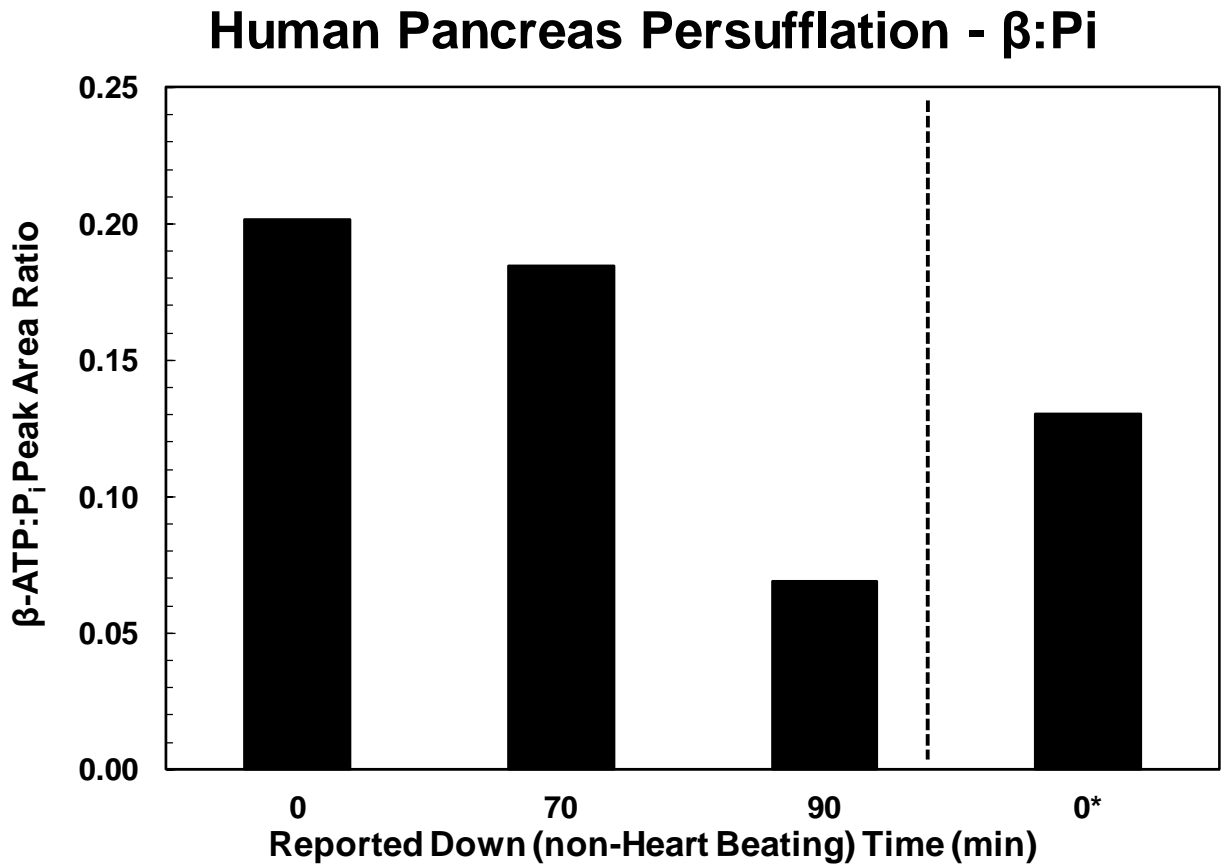


**Figure 5.4:**

Sequential  $\beta$ -ATP: $P_i$  measurements (solid line) relative to initial 8 hour baseline measurements (mean  $\pm$  SEM). In one pancreas (dashed line) PSF was stopped for 3 hours following initial measurements. When PSF was restarted, partial expected recoveries of  $\beta$ -ATP: $P_i$  was observed.

When baseline (8 hour)  $\beta$ -ATP: $P_i$  measurements were compared between 4 persufflated organs, a correlation with exposure to 'down-time' (warm non-heart beating exposure prior to brain death) was observed (Figure 5.5). One organ however seemed to be

'damaged' from our measurements but no 'down time' was reported. When the patient's medical charts were consulted however, a 3 hour 'hypoxia' episode was found.



**Figure 5.5**

$\beta$ -ATP:P<sub>i</sub> ratios collected from 4 persufflating human pancreata following 8 hours of cold ischemia. Reported 'down time' exposure for each pancreas is shown. For one organ (far right; 0\*) no down time was reported, but a 3 hour hypoxic episode was found to have occurred upon further investigation.

This prolonged hypoxic exposure is likely the cause of the lower  $\beta$ -ATP:P<sub>i</sub> ratio observed and shows some potential for the technique to detect damage non-invasively for marginal pancreata. This technique should be investigated further for marginal organs and

correlated with islet isolation outcomes to see if there is indeed a predictive potential for PSF coupled with  $^{31}\text{P}$  NMR spectroscopy to screen out damaged pancreata prior to the expensive (\$15,000/isolation) islet isolation process.

## **Chapter 6: Persufflation Improves Pancreas Histology When Compared with the Two-Layer Method (TLM)**

To correlate whether the improvements in ATP levels during preservation impacted tissue health when exposed to prolonged periods of preservation (24 hours) a study was pursued to compare paired histological outcomes from tissues preserved by either PSF or TLM. A histologist, was consulted to analyze the histological outcomes in a blinded manner. This study is summarized in the original manuscript: **WE Scott III, TD O'Brien, J Ferrer-Fabrega, ES Avgoustiniatos, BP Weegman, T Anazawa, S Matsumoto, VA Kirchner, MD Rizzari, MP Murtaugh, TM Suszynski, T Aasheim, LS Kidder, BE Hammer, SG Stone, L Tempelman, DER Sutherland, BJ Hering, KK Papas: Persufflation Improves Pancreas Preservation When Compared With the Two-Layer Method (TLM); Transplantation Proceedings, 2010 Jul-Aug;42(6):2016-9;** included with permission of Elsevier, the publisher of the journal 'Transplantation Proceedings' (Appendix 6).

Transplantation Proceedings, 42, 2016–2019 (2010)

**Title:**

Persufflation Improves Pancreas Preservation When Compared With the Two-Layer Method<sup>5</sup>

**Authors:**

W.E. Scott III, T.D. O'Brien, J. Ferrer-Fabrega, E.S. Avgoustiniatos, B.P. Weegman, T. Anazawa, S. Matsumoto, V.A. Kirchner, M.D. Rizzari, M.P. Murtaugh, T.M. Suszynski, T. Aasheim, L.S. Kidder, B.E. Hammer, S.G. Stone, L.A. Tempelman, D.E.R. Sutherland, B.J. Hering, and K.K. Papas

---

<sup>5</sup> Research funding provided by a grant from the National Center for Research Resources (U42 RR016598), National Institutes of Health (NIH), National Institute of Diabetes and Digestive and Kidney Diseases (R43 DK070400), NIH, the Schott Foundation, and the Carol Olson Memorial Diabetes Research Fund.

We would like to thank Dr L. Guenther and Dr T. Tanaka for help with early technique development; K. Albeck for technical assistance and manufacturing preservation containers; B. Perrault for surgical assistance; and Dr K.S. Maynard, D. Dudero, G. Wildey, M.L. Graham, L. Mutch, and H. Nelson for administrative assistance.

Address reprint requests to Klearchos K. Papas, PhD, Schulze Diabetes Institute, University of Minnesota Medical School, Mayo Mail Code 195, 420 Delaware St SE, Minneapolis, MN 55455. E-mail: papas006@umn.edu

From the Department of Surgery, Schulze Diabetes Institute (W.E.S., J.F.-F., E.S.A., B.P.W., T.A., S.M., V.A.K., M.D.R., T.M.S., T.A., L.S.K., D.E.R.S., B.J.H., K.K.P.), University of Minnesota, Minneapolis, Minnesota, USA; Department of Veterinary Population Medicine, University of Minnesota, Veterinary Diagnostic Laboratory (T.D.O.), University of Minnesota, St Paul, Minnesota, USA; Department of Veterinary and Biomedical Sciences (M.P.M.), University of Minnesota, St Paul, Minnesota, USA; Department of Radiology, Center for Interdisciplinary Applications in Magnetic Resonance (B.E.H.), University of Minnesota, Minneapolis, Minnesota, USA; and Giner Inc (S.G.S., L.T.), Newton, Massachusetts, USA; Department of Surgery (M.D.R.), University of Texas Southwestern, Dallas, Texas, USA.

Islet transplantation is emerging as a promising treatment for patients with Type 1 diabetes. It is important to maximize viable islet yield for each organ due to scarcity of suitable human donor pancreata, high cost, and the large dose of islets required for insulin independence. However, organ transport for 8 hours using the two-layer method (TLM) frequently results in low islet yields. Since efficient oxygenation of the core of larger organs (eg, pig, human) in TLM has recently come under question, we investigated oxygen persufflation as an alternative way to supply the pancreas with oxygen during preservation. Porcine pancreata were procured from donors after cardiac death and preserved by either TLM or persufflation for 24 hours and subsequently fixed. Biopsies collected from several regions of the pancreas were sectioned, stained with hematoxylin and eosin, and evaluated by a histologist. Persufflated tissues exhibited distended capillaries and significantly less autolysis/cell death relative to regions not exposed to persufflation or to tissues preserved with TLM. The histology presented here suggests that after 24 hours of preservation, persufflation dramatically improves tissue health when compared with TLM. These results indicate the potential for persufflation to improve viable islet yields and extend the duration of preservation, allowing more donor organs to be utilized.

**Introduction:**

Islet transplantation is emerging as a promising treatment for patients with Type 1 diabetes [1, 2]. The minimally invasive nature of the procedure as well as the islets' intrinsic ability to tightly control blood glucose levels on demand via insulin release, offer a combination of advantages that cannot be matched by other presently available treatments, such as self-monitoring or whole-organ pancreas transplantation. Despite recent advances building upon the Edmonton Protocol [3] published in 2000, most centers still require multiple transplants to achieve long-term diabetes reversal [4]. The large dose of islets required, the high cost of the isolation process, and a shortage of suitable donor pancreata demand that we maximize the viable islet yield from each available organ. A lack of proper oxygenation during preservation places hypoxic or anoxic stress on the tissue and may predispose islets to death during the isolation process [5-8]. It has been postulated that improving pancreas preservation via enhanced oxygenation may (1) extend the effective duration of preservation, (2) expand the donor pool up to 10-fold, (3) reduce the immunogenicity of transplanted islets, and (4) reduce the number of donors needed per patient [9]. Presently, the two-layer method (TLM) is the state of the art for pancreas preservation. TLM involves suspending the pancreas between cold preservation solution and a pre-oxygenated perfluorochemical with the goal to improve oxygenation. Recently, the efficacy of TLM has come under scrutiny. While it is adequate to oxygenate smaller pancreata (eg, rat, segmented dog pancreas), diffusion limitations may prevent adequate oxygenation of larger pancreata (eg, pig, human) [10, 11]. Several recent large retrospective studies also reported that TLM provides no significant benefit to isolation outcome, highlighting the need for continued development

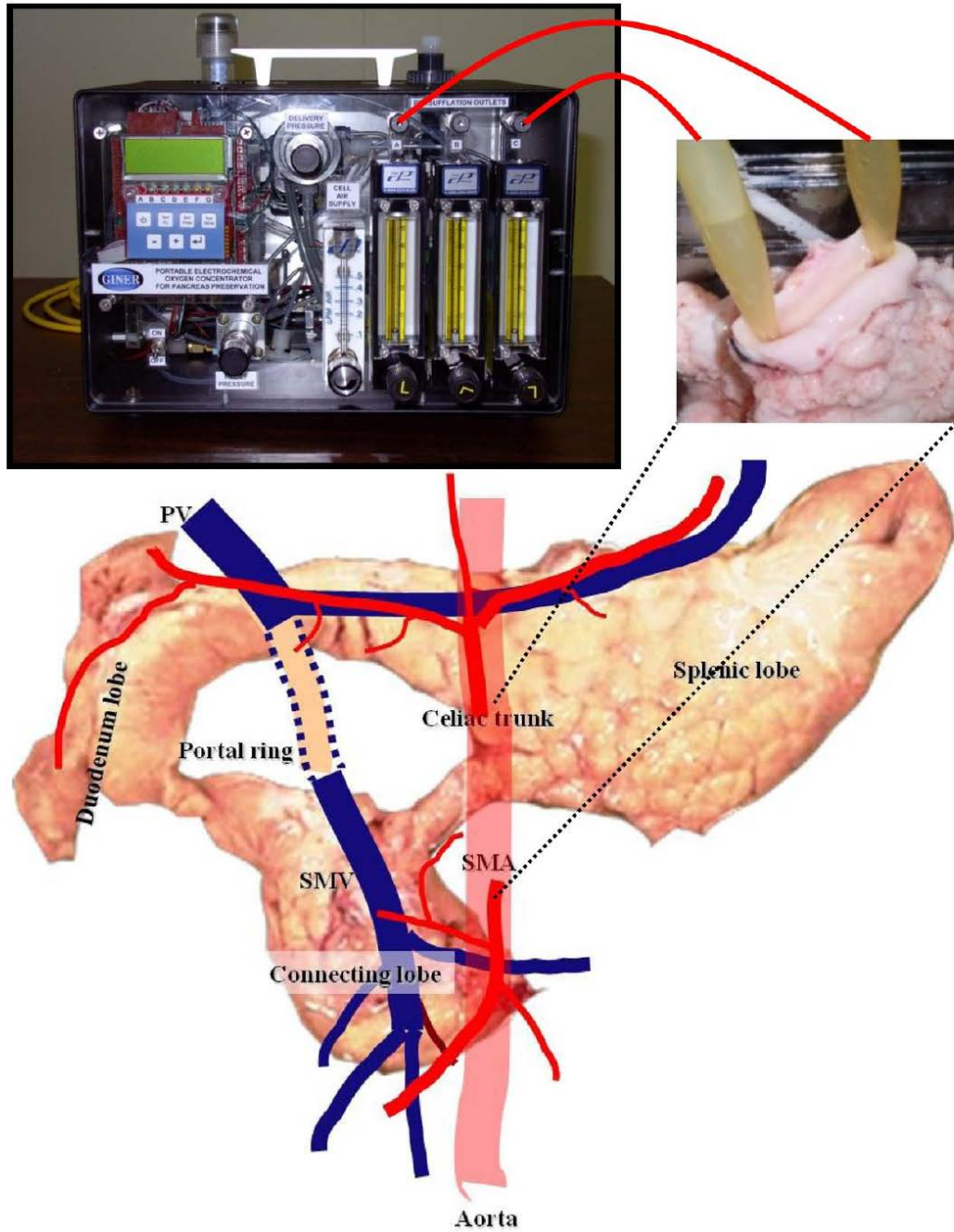


of pancreas preservation protocols [12-14]. Persufflation (PSF; ie, vascular gas perfusion) is one such solution presented here. This method actively delivers oxygen throughout the organ for the duration of preservation, eliminating prolonged periods of hypoxia/anoxia prior to isolation.

## **Methods:**

### **Procurement**

Adult Landrace pigs were systemically anticoagulated with 100,000 U of heparin and euthanized by pentobarbital overdose. The pigs were exsanguinated and eviscerated. The aorta was opened longitudinally followed by cannulation of the celiac trunk (CT) and superior mesenteric artery (SMA) (**Figure 6.1**). The pancreas was then flushed with 5 L of heparinized cold preservation solution (CPS; ie, modified UW solution with 2% penta-starch 1000 U heparin per liter) and the pancreatic duct cannulated and infused with 60 mL of CPS for ductal preservation. Surface cooling was maintained by applying 2 L of moist crushed frozen lactated Ringer's solution (LRS) to the surface, and the surgical field was kept clear by irrigation with chilled LRS. The pancreas with associated vasculature was then resected en bloc from the viscera as described by Ferrer et al [15].



**Figure 6.1:**

Schematic illustrating how the organs were persufflated starting with the electrochemical oxygen concentrator and showing the paths taken by the gas upon entering the organ via celiac trunk and superior mesenteric artery (SMA) until exiting the organ via the portal drainage system. SMV, superior mesenteric vein.

## **Preservation**

Upon removal from the viscera, the pancreas was divided, the connecting and duodenal lobes placed onto TLM, and the splenic lobe preserved by PSF for the duration of the experiment. All lobes were stored at 4 °C throughout preservation.

## **Two-Layer Method**

TLM was performed as previously described [16]. Briefly, lobes were suspended halfway between 1 L of CPS and perfluorodecalin, which was preoxygenated for 1 hour prior to preservation by bubbling with 99% oxygen gas.

## **Persufflation**

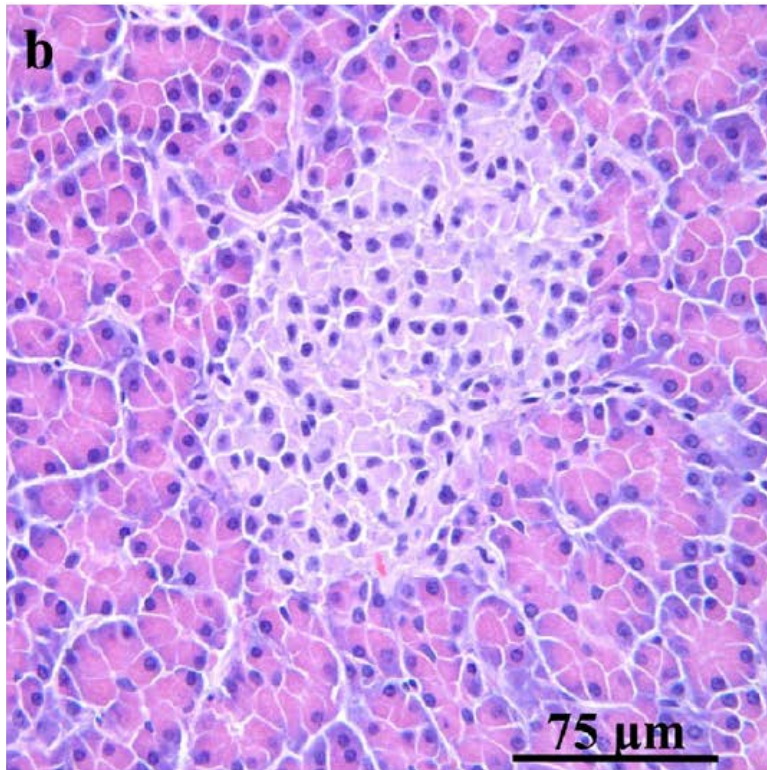
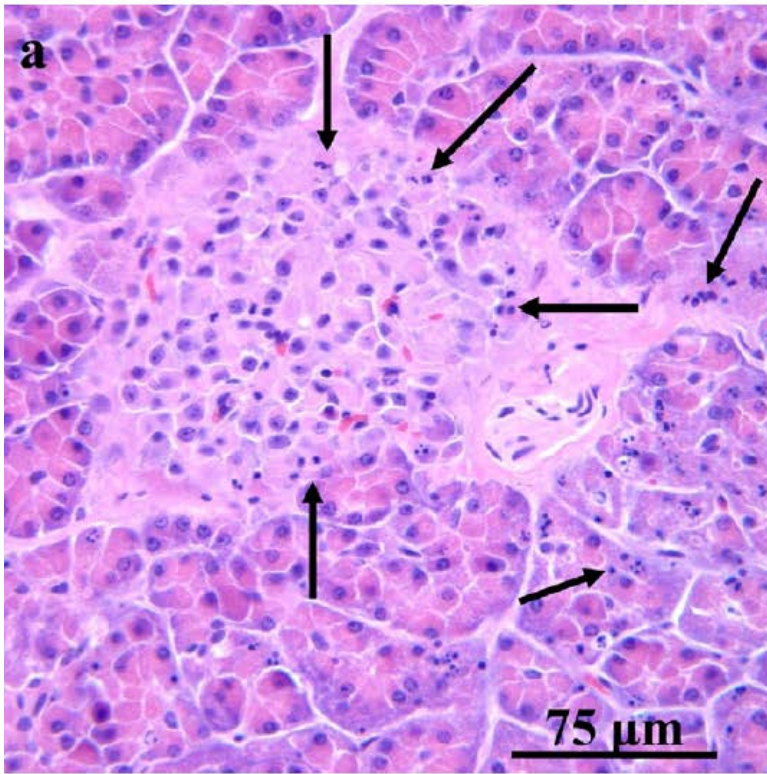
Following division of the pancreas, the splenic lobe was tested for vascular leaks by gentle hand perfusion followed by careful inspection for bubbles upon initiation of PSF. All arterial leaks were tied off. The lobe was then submerged in CPS, and PSF performed with 20 mL/min of humidified 40% oxygen gas supplied to both the CT and SMA at the minimum pressure from which a steady flow could be achieved (typically < 20 mm Hg) for the duration of preservation. Oxygen was supplied from a portable electrochemical oxygen concentrator (Giner Inc, Newton, Mass, USA) and chilled to 4 °C before entering the lobe.

## **Histology**

After 24 hours, the tissues were fixed in 10% buffered formalin for histological analysis. Biopsies were then collected from several regions, embedded in paraffin, sectioned at 4  $\mu\text{m}$ , and stained with hematoxylin and eosin. All slides were then evaluated by an experienced histopathologist (T.D.O., who was blinded as to treatment when slides were scored for extent of autolysis/cell death).

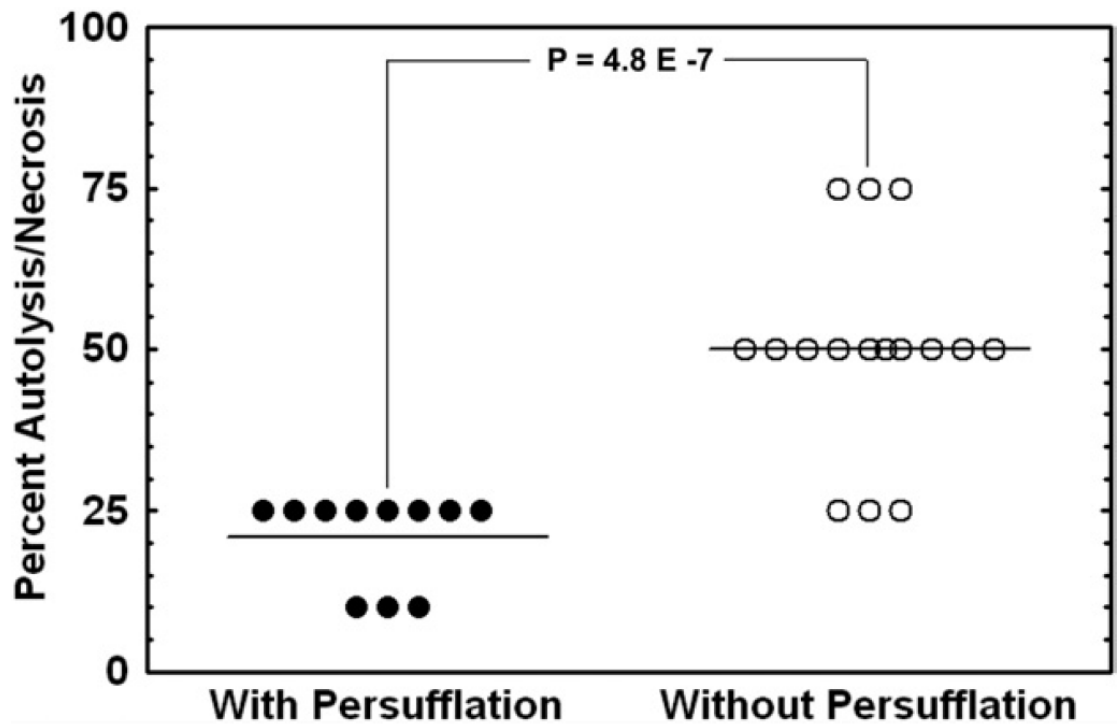
## **Results:**

Biopsies taken from organs preserved for 24 hours with PSF exhibited distended capillaries and less autolysis/necrosis as compared to tissues preserved by TLM for 24 hours (**Figure 6.2**). Of particular note are the pyknotic nuclei observed in TLM samples, which suggest that irreversible damage has occurred, with some cells in the latter stages of cell death. Occasionally, in the earlier stages of technique development, clots were observed in PSF organs, preventing gas flow to these tissues. Histologically, these regions exhibited increased autolysis correlating with the presence of red blood cells and pyknotic nuclei. When biopsies were compared from two of these organs, there was significantly greater autolysis present in nonpersufflated regions ( $P = 4.82\text{E}^{-7}$ ; **Figure 6.3**). These findings indicate that PSF improves tissue health compared to TLM.



**Figure 6.2:**

Representative histological sections from porcine pancreas preserved for 24 hours by (a) the two-layer method and (b) persufflation. The presence of pyknotic nuclei is indicated by arrows.



**Figure 6.3:**

Effect of persufflation on necrosis/autolysis (%). Biopsies were examined from 11 regions with persufflation (black) and 16 regions without persufflation (white) from two porcine pancreata. Lines indicate the mean response.

**Discussion:**

Improving pancreas preservation during organ transport represents a key area of interest for improving islet isolation and transplantation outcomes. Recent studies have suggested that TLM is incapable of adequately oxygenating pancreata (eg, human, porcine), especially their core, and this may limit its usefulness for pancreas preservation. PSF offers an alternate way of delivering oxygen to the entire organ throughout preservation by using the native vasculature. The histological analysis presented here suggests that PSF dramatically improves tissue health when compared with static methods of organ preservation, such as TLM, for 24 hours. These findings agree with recent porcine isolation outcomes in our lab, which in a paired comparison show greater numbers of islets of a higher quality following culture as determined by oxygen consumption rate to DNA ratio, a measure of viability [17], and islet morphology. In the clinical setting, PSF may expand the deceased donor pool by improving the preservation of marginal organs, in turn leading to a greater number of successful transplantations.

We conclude that pancreas PSF should be investigated further to assess its potential as a novel method of pancreas preservation.

## References:

1. Shapiro AM, Lakey JR, Ryan EA, et al: Islet transplantation in seven patients with type 1 diabetes mellitus using a glucocorticoid-free immunosuppressive regimen. *N Engl J Med* 343:289, 2000
2. Shapiro AM, Ricordi C, Hering B: Edmonton's islet success has indeed been replicated elsewhere. *Lancet* 362:1242, 2003
3. Shapiro AM, Lakey JR, Ryan EA, et al: Islet transplantation in seven patients with type 1 diabetes mellitus using a glucocorticoid-free immunosuppressive regimen. *N Engl J Med* 343:230, 2000
4. Hering BJ, Kandaswamy R, Ansite JD, et al: Single donor marginal dose islet transplantation in patients with type 1 diabetes. *JAMA* 293:830, 2005
5. Wang GL, Semenza GL: General involvement of hypoxia inducible factor 1 in transcriptional response to hypoxia. *Proc Natl Acad Sci USA* 90:4304, 1993
6. Dionne KE, Colton CK, Yarmush ML: Effect of hypoxia on insulin secretion by isolated rat and canine islets of Langerhans. *Diabetes* 42:12, 1993
7. Moritz W, Meier F, Stroka DM, et al: Apoptosis in hypoxic human pancreatic islets correlates with HIF-1 alpha expression. *FASEB J* 16:745, 2002
8. Bruick RK: Expression of the gene encoding the proapoptotic Nip3 protein is induced by hypoxia. *Proc Natl Acad Sci U S A* 97:9082, 2000
9. Hering BJ, Matsumoto I, Sawada T, et al: Impact of two-layer pancreas preservation on islet isolation and transplantation. *Transplantation* 74:1813, 2002
10. Avgoustiniatos ES, Hering BJ, Papas KK: The rat pancreas is not an appropriate model for testing the preservation of the human pancreas with the two-layer method. *Transplantation* 81:1471, 2006
11. Papas KK, Hering BJ, Guenther L, et al: Pancreas oxygenation is limited during preservation with the two-layer method. *Transplant Proc* 38:3501, 2005
12. Kin T, Mirbolooki M, Salehi P, et al: Islet isolation and transplantation outcomes of pancreas preserved with University of Wisconsin solution versus two-layer method using preoxygenated perfluorocarbon. *Transplantation* 82:1286, 2006
13. Caballero-Corblan J, Eich T, Foss A, et al: No beneficial effect of the two layer method (PFCUW) compared with transportation in UW alone on the outcome of human islet isolation and transplantation: a report on 214 human pancreases. *Am J Transplant* 2:(6 Suppl):340, 2006
14. Caballero-Corblan J, Eich T, Lundgren T, et al: No beneficial effect of two-layer storage compared with UW-storage on human islet isolation and transplantation. *Transplantation* 84:864, 2007
15. Ferrer J, Scott WE III, Weegman BP, et al: Pig pancreas anatomy: implications for pancreas procurement, preservation, and islet isolation. *Transplantation* 86:1503, 2008
16. Kuroda Y, Kawamura T, Suzuki Y, et al: A new, simple method for cold storage of the pancreas using perfluorochemical. *Transplantation* 46:457, 1988
17. Papas KK, Colton CK, Nelson RA, et al: Human islet oxygen consumption rate and DNA measurements predict diabetes reversal in nude mice. *Am J Transplant* 7:707, 2007



## **Chapter 7: Persufflation Improves Pancreas Preservation for Islet Isolation when Compared with the Two-Layer Method (TLM)**

In order to determine if the improved ATP levels observed are truly beneficial; a comparison of islet isolation outcomes from PSF and a state of the art method of preservation such as TLM must be compared. An initial study comparing PSF and TLM was performed in a donation after cardiac death model. This work is summarized in the following manuscript presently in preparation for journal submission.

# **Persufflation Improves Porcine Pancreas Preservation for Islet Isolation when Compared with the Two-Layer Method (TLM)**

## **Title:**

Persufflation Improves Porcine Pancreas Preservation for Islet Isolation when Compared with the Two-Layer Method (TLM)<sup>6</sup>

## **Authors:**

WE Scott III<sup>A,B</sup>, ES Avgoustiniatos<sup>A</sup>, J Ferrer-Fabrega<sup>A</sup>, BP Weegman<sup>A</sup>, AN Balamurugan<sup>A</sup>, T Anazawa<sup>A</sup>, S Matsumoto<sup>A</sup>, MD Rizzari<sup>A</sup>, TM Suszynski<sup>A</sup>, VA Kirchner<sup>A</sup>, TD O'Brien<sup>C</sup>, MP Murtaugh<sup>D</sup>, TC Aasheim<sup>A</sup>, LS Kidder<sup>A</sup>, BE Hammer<sup>E</sup>, SG Stone<sup>F</sup>, LA Tempelman<sup>F</sup>, DER Sutherland<sup>A</sup>, BJ Hering<sup>A</sup>, KK Papas<sup>A,B,G</sup>

---

<sup>6</sup> Research funding provided by a grant from the National Center for Research Resources (U42 RR016598), National Institutes of Health (NIH), National Institute of Diabetes and Digestive and Kidney Diseases (R43 DK070400), NIH, the Schott Foundation, and the Carol Olson Memorial Diabetes Research Fund. We would like to thank Dr. L Guenther and Dr. T Tanaka for help with early technique development; K Albeck for technical assistance and manufacturing preservation containers; B Perrault for surgical assistance; D Duderu, Dr. M Graham, Dr. K Maynard, L Mutch, H Nelson and G Wildey, for administrative assistance.

<sup>A</sup>University of Minnesota, Department of Surgery, Schulze Diabetes Institute, Minneapolis, Minnesota, USA.

<sup>B</sup>University of Arizona, Department of Surgery, Institute for Cellular Transplantation, Tucson, Arizona, USA.

<sup>C</sup>University of Minnesota, Department of Veterinary Medicine, Veterinary Diagnostic Laboratory, St. Paul, Minnesota, USA.

<sup>D</sup>University of Minnesota, Department of Veterinary and Biomedical Sciences, St. Paul, Minnesota, USA.

<sup>E</sup>University of Minnesota, Department of Radiology, Center for Interdisciplinary Applications in Magnetic Resonance, Minneapolis, Minnesota, USA.

<sup>F</sup>Giner Inc., Newton, Massachusetts, USA.

<sup>G</sup>Address correspondence to Klearchos K. Papas, PhD, Institute for Cellular Transplantation, University of Arizona, Abdominal Transplant: PO Box 245066; Tucson, Arizona 85724-5066, E-mail: [kkpapas@surgery.arizona.edu](mailto:kkpapas@surgery.arizona.edu).

**Introduction:**

Islet transplantation is an emerging treatment for type-1 diabetes. Many pancreata are exposed to >6-8 hours of cold ischemia (CI) reducing viable islet yields. The efficacy of the two-layer method (TLM) is disputed, since human-sized pancreata can't be oxygenated by surface diffusion alone. Persufflation (PSF) shows potential to oxygenate the pancreas intravascularly throughout preservation.

**Methods:**

Using a donation after cardiac death model, porcine pancreata were procured and divided into lobes and preserved as follows: connecting lobes were preserved by TLM for 24 hours; splenic lobes were persufflated for 24 hours by delivering 20 + 20 cc/min 40% humidified-oxygen gas to the celiac trunk and the superior mesenteric artery. Following preservation, islets were isolated, cultured for 2 days, and assessed.

**Results:**

Persufflated islets exhibited better outcomes based on yields as measured by counts or DNA, and quality as assessed by morphology ( $p < 0.05$ ), oxygen consumption rate per DNA content ( $p < 0.05$ ), and post-culture recovery compared with TLM preserved islets. Persufflated islets also exhibited diabetes reversal rates in nude mice comparable with historical data for minimal CI time.

**Conclusion:**

PSF delivers oxygen throughout the pancreas, improving islet yields and quality relative to TLM. PSF shows promise for extending the duration of cold preservation.

**Abbreviations:**

CPS	Cold preservation solution
CT	Celiac trunk
DCD	Donation after cardiac death
IE	Islet equivalent
OCR	Oxygen consumption rate
pO <sub>2</sub>	Oxygen partial pressure
PSF	Persufflation
SEM	Standard error of the mean
SMA	Superior mesenteric artery
TLM	Two-layer method

## **Introduction:**

Islet transplantation is emerging as a promising treatment for patients with type-1 diabetes [1, 2]. The minimally invasive nature of the procedure, the islets' intrinsic ability to tightly control blood glucose levels via on demand insulin release, and the prospect of improved patient quality of life give islet transplantation a combination of therapeutic features unmatched by other presently available treatments, such as conventional insulin self-administration or solid organ pancreas transplantation [3]. Despite advances since the establishment of the Edmonton Protocol [1, 4-6], most centers still require multiple transplants to achieve long-term insulin independence [7, 8]. The large islet dose requirement for single-donor transplant success, and the high cost of the isolation process, demand that the viable islet yield from each available organ be maximized.

A lack of adequate oxygenation during preservation places hypoxic or anoxic stress on the tissue and may pre-dispose islets to irreversible damage during the isolation process [9-12]. It has been postulated that improving pancreas preservation via enhanced oxygenation may: 1) extend the effective duration of preservation, 2) expand the useable donor pool up to 10-fold, 3) reduce the immunogenicity of transplanted islets, and 4) reduce the number of donors needed per patient [13]. Presently, the two-layer method (TLM), an advanced form of static cold preservation, is the state of the art for pancreas preservation prior to islet isolation. TLM involves suspending the pancreas between cold preservation solution (CPS) and a pre-oxygenated perfluorochemical to improve oxygenation during preservation. Recently, the efficacy of TLM has come under scrutiny. While it may be adequate to oxygenate smaller pancreata (e.g., rat, segmented dog),

oxygen diffusion limitations prevent oxygenation of significant volume fraction's for larger pancreata (e.g., pig, human) [14, 15]. Consistent with these findings, several recent large retrospective studies have reported that TLM provides no significant benefit to isolation outcome, highlighting the need for continued development of pancreas preservation protocols[16-18]. Persufflation (PSF), a synonym for vascular gas perfusion, presents a promising alternative strategy for improved pancreas preservation.

PSF utilizes the native vasculature to actively deliver gaseous oxygen throughout an organ for the duration of preservation. This enables adequate tissue oxygenation for the duration of preservation and prevents hypoxic or anoxic exposure associated with static preservation methods such as TLM. PSF has previously been investigated for preservation of heart [19-21], liver [22-25], kidney [26-28], small bowel [29], and by our group in the pancreas [30, 31]. In addition, one of these studies investigated its clinical application in the liver [25]. Historically, two approaches to PSF have been pursued in depth: antegrade (gas enters from the arterial and exits through the venous system) and retrograde (gas enters from the venous system and exits through needle punctures created in the organ surface). Each of these approaches has distinct advantages and should be considered on an organ to organ basis. In order to properly preserve the pancreas for islet isolation, the ductal network must remain intact for subsequent enzymatic distention eliminating the option of puncturing the pancreas. Therefore, antegrade PSF was pursued.



To perform PSF for the duration of preservation, a portable means for generating and delivering oxygen at desired pressures and concentrations is required. In order to carry the system on flights returning from distant procurement sites an alternative to traditional gas cylinders was required. To accomplish this, collaboration was pursued with Giner Inc. (Newton, MA) to develop a portable-electrochemical oxygen generator (EOC) device for PSF (**Figure 7.1**). This device enabled us to apply PSF continuously beginning immediately following procurement on the back table until immediately prior to islet isolation at a different local facility.

To test the efficacy of PSF for islet isolation, we compared paired porcine pancreatic lobes procured using a donation after cardiac death (DCD) model and preserved either in CPS for <2.5 hours (as is standard practice for porcine islet isolations), or for 6 or 24 hours by either TLM or PSF. Islet isolation outcomes were compared on the day of isolation and after 2 days of culture using islet counts, morphology, DNA content, oxygen consumption rate normalized to DNA (OCR/DNA), a measure of fractional viability, and the diabetic nude mouse bioassay.

**Methods:****Procurement:**

The DCD porcine model utilized has been described in detail previously [32]. Briefly, adult Landrace pigs were systemically treated with 100,000 U of heparin, euthanized by pentobarbital overdose, exsanguinated, and eviscerated. The aorta was opened longitudinally followed by cannulation of the celiac trunk (CT) and superior mesenteric artery (SMA) (**Figure 7.1**). The pancreas was then intravascularly flushed with 5 L of heparinized CPS (cold storage/purification stock solution, Mediatech, Inc., Manassas, Va) and the pancreatic duct cannulated and infused with 60 mL of CPS for ductal preservation. Surface cooling was employed by applying 2 L of moist crushed frozen lactated-Ringer's solution (LRS) to the surface of the pancreas as needed and the surgical field was kept clear by irrigation with chilled LRS. The pancreas along with associated vasculature was then excised *en bloc* from the viscera [32].

**Preservation:**

Upon removal from the viscera, the pancreas was divided into its constituent lobes and each lobe was then preserved as follows: duodenal lobes were stored in CPS and isolated <2.5 hours after procurement as is standard practice for porcine islet isolation; connecting lobes were preserved by TLM for either 6 or 24 hours; splenic lobes were persufflated for either 6 or 24 hours. All lobes were stored at 4 °C throughout preservation. Rotation of conditions was not performed because, based on prior anatomical studies, once the organ is split as required for the paired comparison, only the splenic lobe can be completely persufflated [32].

**TLM:**

TLM was performed as previously described [33]. Briefly, tissue was suspended half way between 1 L of CPS and 600 mL of perfluorodecalin, which was pre-oxygenated for 1 hour prior to preservation by bubbling with 99% oxygen gas.

**PSF:**

Following division of the pancreas, the splenic lobe was tested for vascular leaks by gentle hand perfusion with a 60 cc syringe. This was followed by careful inspection for gas bubbles upon initiation of PSF. All arterial leaks were tied off. The tissue was then submerged in CPS and PSF performed with 20 cc/min of humidified 40% oxygen balance air gas supplied through both the CT and SMA at the minimum pressure required for a steady flow (typically < 20 mm Hg) for the duration of preservation. Gas mixtures were supplied at the desired concentration and pressures via a portable electrochemical oxygen concentrator (Giner Inc, Newton MA) and chilled before being delivered into the tissue.

**Islet Isolation:**

Islet isolation was performed as previously described [34, 35]. Briefly, following preservation, individual pancreas lobes were manually distended via the ductal network with cold enzyme solution. Switch points were determined by monitoring the tissue until islets were free from acinar tissue. Pig islets were purified using continuous iodixanol (OptiPrep, Axis-Shield, Oslo, Norway) density gradients in a COBE-2991 cell separator

(Gambro BCT, Lakewood, CO). Pure fractions were determined by visual inspection. Purity was >90% in all cases.

### **Islet Culture:**

Islets were cultured for 2 days at 37 °C in MEM-199 media supplemented with 10% commercial porcine serum, 5 mM L-glutamine, and 10,000 U/L heparin in culture flasks with silicone rubber membrane bottoms (Wilson-Wolf, Minneapolis, MN) which allow islet culture at higher surface densities by means of enhanced oxygen transfer [36]. Islet surface density was kept below 1,000 IE/cm<sup>2</sup>.

### **Islet Quality Assessment:**

**Islet counts:** On the day of isolation (DOI) and following 2-day culture, pooled islet preparations were sampled (2 x 100 µL), stained with dithizone, and assessed both for islet yield and purity as previously described [37]. Briefly, islets were counted and sorted based on diameter in 50 µm increments. The total islet volume was then calculated and converted into islet equivalents (IE, a volume unit equal to the volume of a 150 µm diameter islet).

**Islet morphology:** Dithizone-stained islet count samples were also scored for morphology on a 10-point scale. The total score was calculated by summing 5 categories, equally weighted: 1) three-dimensional shape, with more points awarded to more spherical islets; 2) two-dimensional border, with more points awarded to well rounded islets; 3) integrity, with more points awarded to more solid/compact islets; 4) presence of

single cells, with more points awarded to preparations with less single cells; 5) diameter, with more points awarded for larger diameter islets. Photomicrographs were also recorded at several magnifications.

**DNA yield and recovery:** On the DOI and following 2-day culture, 5 x 100  $\mu$ L samples were collected from pooled islets, sonicated, diluted, and stained with fluorescent DNA stain. Samples were then processed according to the Quant-iT PicoGreen dsDNA kit (Molecular Probes, Eugene, OR) in 96-well plates and compared with a standard curve to determine the DNA concentration.

Islet yields based on DNA were reported in IE based on DNA (DNA-IE) using the conversion factor of 10.4 ng DNA per IE. Islet recoveries were calculated taking into account the number of islets removed before and during culture for islet assessment or distribution.

**Oxygen consumption rate normalized to DNA (OCR/DNA):** Islet viability was assessed by OCR/DNA as previously described [38]. Briefly, islet samples were placed into gas-sealed, stirred OCR measurement chambers equipped with fiber-optic sensors (Inotech Laboratories, Plymouth Meeting, PA). Chambers were maintained at 37 °C and medium oxygen partial pressure ( $pO_2$ ) was monitored over time. Once media  $pO_2$  declined below 80 mm Hg, islets were removed and chambers washed for DNA measurements, as described above for cultured islets. The chamber volume was utilized to determine the OCR of the islets and normalized to the total DNA recovered from the

chamber to determine the OCR/DNA (nmol O<sub>2</sub>/min/mg DNA). Measurements from 2-3 chambers were simultaneously collected for each preparation with the mean value used for statistical comparisons.

**Diabetic nude mouse bioassay:** All animal procedures were approved by the Institutional Animal Care and Use Committees (IACUC) at the University of Minnesota. The bioassay was performed as previously described [39]. Briefly, nude mice were intraperitoneally injected with streptozotocin to induce diabetes. Following 2-day culture, 2,000 IE were transplanted into each mouse under the kidney capsule. Blood glucose values were monitored for 30 days at which time the graft was removed by nephrectomy and the mice monitored to demonstrate the return of hyperglycemia.

**Statistics:** Isolation outcomes were compared by a paired students t-test. All values are reported as the mean  $\pm$  SEM. Comparisons were considered statistically significant for  $p < 0.05$  and highly statistically significant for  $p < 0.01$ .

## **Results:**

For the 6-hour preservation arm of the study, 4 pancreata were used. All islet preparations were of high purity (> 90%), as assessed by visual estimation during islet counting. Similar fractions of undigested tissue remaining in the Ricordi chamber following digestion were observed for all conditions. Islets were characterized on the day of isolation as well as following 2-day culture, the standard culture time for our clinical islets. For all assays investigated, PSF islets were similar to those obtained from the paired duodenal lobes that underwent our standard pig isolation procedure. PSF islet morphology scores were consistently better than TLM islets with statistical significance observed following isolation ( $p = 0.037$ ) but not after 2-day culture ( $p = 0.13$ ). PSF islets had a significantly greater average diameter than TLM islets on both the day of isolation (14%,  $p = 3.0 \cdot 10^{-3}$ ) as well as following 2-day culture (17%,  $p = 0.031$ ). A trend towards statistical significance for OCR/DNA, was also observed following 2-day culture (15%,  $p = 0.078$ ). All other assays investigated exhibited no statistically significant differences, with most measurements favoring PSF over TLM, including all assays following culture.

For the 24-hour preservation arm of the study, 8 pancreata were used. All islet preparations were of high purity (>85%) as assessed by visual estimation during islet counting. As was the case following 6-hour preservation, similar amounts of undigested tissue remained in the Ricordi chamber following digestion for all conditions. For all assays investigated, PSF islets were similar to those obtained from the paired duodenal lobes that underwent standard pig isolation procedure. Islets isolated following 24-hour PSF were generally healthier than paired islets isolated following paired 24-hour TLM

preservation. A summary of all investigated assays comparing PSF with TLM is presented in **Table 7.1**.

Following culture, OCR/DNA values were consistently better for PSF, with a highly statistically significant increase (16%,  $p = 4.9 \cdot 10^{-3}$ ) observed (**Figure 7.2**). Islet morphology following isolation as well as following 2-day culture was consistently better with PSF relative to TLM, however no statistical significance was observed. Both the DNA content per gram of digested tissue ( $p=0.030$ ) as well as the total OCR per gram of digested tissue ( $p=0.013$ ) were consistently better with statistical significance on the day of isolation for PSF relative to TLM (**Figure 7.2**). Islet recovery after 2-day culture as assessed by either islet counts or DNA measurements was better for PSF relative to TLM but without statistical significance. Representative images of islets obtained from paired lobes preserved with the TLM and PSF are shown in **Figure 7.3** to demonstrate the morphological quality of islets obtained from each method of preservation. The ratio of IE per islet counted, the mean islet diameter, as well as the number of IE per gram digested tissue were all significantly better for PSF following isolation with a trend towards significance observed following culture. Diabetic nude mice transplanted following culture with islets preserved for 24 hours by PSF exhibited similar rates of diabetes reversal when compared with historical controls (**Figure 7.4**). Comparison of diabetes reversal rates for PSF was done against historical controls rather than paired controls or TLM islets. This was due to the small size of these lobes and the low post-culture islet recoveries obtained from TLM lobes that resulted in insufficient islets for mouse transplants for most pancreata.



## **Discussion:**

Traditional methods of pancreas preservation that rely on tissue oxygenation by surface diffusion alone have been shown to be inadequate as a means to oxygenate the core of human or porcine pancreata even under cold preservation temperatures[15]. It is believed that the pancreas, and in particular the islets, may be acutely sensitive to hypoxic stresses and that prolonged exposure to anoxic conditions inhibits successful islet isolation from organs exposed to >8 hours of preservation. This work investigates PSF as an alternate method to preserve the pancreas by providing gaseous oxygen throughout the native vasculature. By delivering oxygen throughout the organ, PSF is able to better cope with metabolic demands and maintain tissue ATP content allowing the cells to better maintain viability during hypothermic preservation [30].

One of the main barriers to the application of PSF has been the inherent difficulties of transporting oxygen gas cylinders during organ transport. To address this, the expertise of Giner Inc. (Newton, MA) was enlisted to produce a miniaturized version of their electronic oxygen concentrator (EOC) technology. This eliminated the need for bulky gas cylinders during PSF and has allowed us to locally transport organs, maintaining PSF throughout preservation; even when air transport has been required. The EOC (**Figure 7.1**) has allowed us to begin PSF on the back table in the operating room, test for and ligate smaller leaks in the vasculature, and continuously persufflate the pancreas until islet isolation. Additionally, the EOC allowed us to ‘dial in’ precise concentrations and flow rates of humidified gas with fine control of inlet gas pressures to within 1 mm Hg for both the CT and SMA. Pressures required were generally low and typically in the 7-

22 mm Hg range. The 40% oxygen gas content was selected based on theoretical considerations and after a brief optimization to balance the need to deliver oxygen throughout the organ with the negative effects observed after prolonged exposure of islets to oxygen partial pressures over 300 mm Hg (unpublished observations, Papas).

Due to the logistical challenges involved in developing and testing the technique in human organ donors, a DCD porcine model was chosen as an initial model to investigate the efficacy of PSF for two reasons: 1) the porcine pancreas has similar dimensions as the human pancreas imposing similar oxygen diffusion limitations and 2) the ability to routinely isolate islets with this model at the University of Minnesota without the logistical issues associated with the unpredictable human pancreas availability.

Pilot studies comparing PSF with TLM utilizing  $^{31}\text{P}$ -NMR spectroscopy to investigate organ ATP content [30] as well as histology [31] demonstrated a direct benefit of PSF compared with TLM. For isolation studies, a 6-hour preservation period was initially investigated to examine PSF impact on organs stored for a clinically relevant time frame and to test whether PSF inherently inhibited the ability to successfully isolate islets when compared with TLM, the present state-of-the-art method for pancreas preservation. After 4 replicates, we found that islets obtained following 6-hour PSF exhibited consistently better outcomes than those obtained from paired lobes preserved for 6-hours by TLM, with no major differences observed relative to islets isolated from paired control lobes that underwent 2-3 hours cold preservation as per our standard porcine islet isolation procedure. Due to this finding and the desire to test whether we can improve utilization of

the available donor pool by improving and prolonging cold preservation, it was decided to extend the duration of preservation to 24 hours for the remainder of the study. If organs could be preserved for 24 hours without significant impairment to islet isolation outcome, more organs could be placed for clinical islet isolation reducing the need for maintaining a 24-hour on call staff for isolation.

Following 8 replicates with 24-hour preservation, we observed significant improvements with PSF relative to the TLM in many of our quality control assays. The amount of undigested tissue present in the Ricordi chamber following digestion being similar for all conditions, suggests that the amount of undigested tissue may not be impacted by the duration or method of preservation. Other means of improving the efficiency of digestion, such as better distention or improved enzyme blends should be pursued. All isolations were of a high purity as assessed by dithizone staining with no significant differences observed. These results suggest that preservation does not dramatically impact purity in the pig model where most preparations are of high purity. However, when higher magnification photomicrographs (**Figure 7.3**) were examined, we found that TLM-preserved islets had a greater degree of small fragments of acinar tissue distributed throughout the preparation which may not be accounted for during the counting process. The presence of these small fragments suggests that when PSF is translated into the human pancreas, preservation may improve purity and proper attention to purity measurements is being given presently in follow-up studies involving human pancreata.

All morphological assessments of islet quality, including morphology score, the IE:islet number ratio, and islet size favored PSF relative to TLM with statistical significance on the day of isolation and trends towards statistical significance following culture. When islets were examined at various magnifications under the microscope (**Figure 7.2**), larger, more rounded and intact islets were consistently observed with PSF. These findings suggest that exposure to prolonged hypoxic cold preservation may contribute to fragmentation of the islet borders and loss of islet mass. Indeed, the islet yield per gram of digested tissue based on counts was significantly greater for PSF when compared with TLM on the day of isolation and trended higher following culture. The lack of statistical significance post-culture as assessed by counts is most likely due to the increased variability of these counts with some digests having dramatically worse post-culture recoveries than others especially for TLM.

When islet mass was estimated based on the DNA present in culture, islet yield was statistically significantly higher for PSF relative to TLM both on the day of isolation as well as following culture. This increase in islet mass per gram digested tissue was accompanied by consistently higher islet viability as measured by OCR/DNA on the day of isolation and statistically significantly higher islet viability following culture. When the higher islet yields are combined with the better viability measurements, significantly greater yields of total viable tissue mass per gram of digested tissue (total OCR per gram digested tissue) were observed for PSF both on the day of isolation as well as following culture. Post-culture islet recoveries as assessed by either counts or DNA were higher for

PSF but statistical significance was not observed, likely due to the high isolation to isolation variability.

The causes of the apparent damage to islet borders and potential loss of cells from the islet rim as well as the overall reduced viability of islet tissue associated with 24 hours TLM relative to 24 hours PSF is of particular importance. The impaired islet morphology may be due to islet cell death and subsequent sloughing off at the islet periphery. This would be an example of a direct cause of islet destruction that could be exacerbated by prolonged exposure to low temperature, or a lack of oxygen or other nutrients and may explain the reduced islet viability observed by OCR/DNA observed with 24 hours TLM. If it were simply due to prolonged exposure to cold, however, this damage should be experienced by the PSF tissue as well and so we believe that the prolonged ischemia experienced by islets exposed to 24 hours TLM preservation is the main direct mechanism causing islet cell death and reduced yields following prolonged preservation.

There may also be mechanisms at work not directly related to the islets themselves but rather to damage sustained by the surrounding acinar tissue. Acinar cells may be experiencing an elevated  $\text{Ca}^{++}$  toxicity during cold preservation which can cause autolysis and subsequent release and activation of endogenous pancreatic enzymes. This mechanism has been implicated in hypothermic-preservation related damage in the liver [40], kidney, as well as other tissues [41] and would explain the patchy regions of autolysis we have previously observed histologically [31]. The elevated  $\text{Ca}^{++}$  cell death mechanism has also been shown to play a role in acute pancreatitis [42-45] and has been

shown to result from a lack of adequate ATP, either due to an ischemic episode or to some other method of inhibition of ATP generation [45]. If this is the mechanism at work and pancreatic enzymes are being activated and released during preservation, these enzymes may move into the outer layers of nearby islets and digest these cells away, leaving a smaller islet with rough borders. The fact that significantly smaller islets (possibly islet fragments) were observed with TLM relative to PSF would fit with our previous observation that inferior oxygenation due to traditional static preservation methods such as TLM results in a lack of ATP [30]. As this period of anoxia is prolonged, more acinar cells are likely to experience toxic levels of  $\text{Ca}^{++}$  and undergo autolysis. This process may take some time under hypothermic conditions and may help explain the reduced islet yield observed from long-term (>8 hours) preserved pancreata. Additional studies exploring this possible mechanism are warranted.

Due to the small size of the duodenal and connecting lobes and the low recoveries associated with 24 hours of TLM preservation, the diabetic nude mouse bioassay could not be performed with control or TLM islets for most of the isolations performed. We therefore compared PSF-preserved islets to a cohort of recent historical controls comprised of transplants performed with islets isolated with the standard isolation procedure. Islets preserved for 24 hours by PSF were found to have no significant or practical difference in terms of overall diabetes reversal rates or the time to diabetes reversal. This finding indicates no incremental functional impairment was experienced by islets exposed to 24 hours of PSF relative to islets isolated shortly after procurement.

In conclusion, PSF offers a promising alternative to presently available methods of pancreas preservation. It enables improved oxygenation by actively supplying tissue with oxygen delivered throughout the native vasculature. This improved oxygenation resulted in greater numbers of healthier, more viable islets when compared with TLM and islets of similar numbers and quality when compared with minimal cold preservation (2-3 hours) exhibiting potential for extending cold preservation beyond the typically acceptable 8 hours to 24 hours. This would enable more organs to proceed to transplantation and demands that PSF be investigated further.

## References:

1. Shapiro AM, Lakey JR, Ryan EA, Korbitt GS, Toth E, Warnock GL et al. Islet transplantation in seven patients with type 1 diabetes mellitus using a glucocorticoid-free immunosuppressive regimen. *N Engl J Med* 2000;343(4):230-238.
2. Shapiro AM, Ricordi C, Hering B. Edmonton's islet success has indeed been replicated elsewhere. *Lancet* 2003;362(9391):1242.
3. Frank AM, Barker CF, Markmann JF. Comparison of whole organ pancreas and isolated islet transplantation for type 1 diabetes. *Adv Surg* 2005;39:137-163.
4. Ryan EA, Lakey JR, Rajotte RV, Korbitt GS, Kin T, Imes S et al. Clinical outcomes and insulin secretion after islet transplantation with the Edmonton protocol. *Diabetes* 2001;50(4):710-719.
5. Ryan EA, Lakey JR, Paty BW, Imes S, Korbitt GS, Kneteman NM et al. Successful islet transplantation: continued insulin reserve provides long-term glycemic control. *Diabetes* 2002;51(7):2148-2157.
6. Ryan EA, Paty BW, Senior PA, Bigam D, Alfadhli E, Kneteman NM et al. Five-year follow-up after clinical islet transplantation. *Diabetes* 2005;54(7):2060-2069.
7. Hering BJ, Kandaswamy R, Ansite JD, Eckman PM, Nakano M, Sawada T et al. Single-donor, marginal-dose islet transplantation in patients with type 1 diabetes. *JAMA* 2005;293(7):830-835.
8. Shapiro AM, Ricordi C, Hering BJ, Auchincloss H, Lindblad R, Robertson RP et al. International trial of the Edmonton protocol for islet transplantation. *N Engl J Med* 2006;355(13):1318-1330.
9. Wang GL, Semenza GL. General involvement of hypoxia-inducible factor 1 in transcriptional response to hypoxia. *Proc Natl Acad Sci U S A* 1993;90(9):4304-4308.
10. Dionne KE, Colton CK, Yarmush ML. Effect of hypoxia on insulin secretion by isolated rat and canine islets of Langerhans. *Diabetes* 1993;42(1):12-21.
11. Moritz W, Meier F, Stroka DM, Giuliani M, Kugelmeier P, Nett PC et al. Apoptosis in hypoxic human pancreatic islets correlates with HIF-1alpha expression. *FASEB J* 2002;16(7):745-747.
12. Bruick RK. Expression of the gene encoding the proapoptotic Nip3 protein is induced by hypoxia. *Proc Natl Acad Sci U S A* 2000;97(16):9082-9087.
13. Hering BJ, Matsumoto I, Sawada T, Nakano M, Sakai T, Kandaswamy R et al. Impact of two-layer pancreas preservation on islet isolation and transplantation. *Transplantation* 2002;74(12):1813-1816.
14. Avgoustiniatos ES, Hering BJ, Papas KK. The rat pancreas is not an appropriate model for testing the preservation of the human pancreas with the two-layer method. *Transplantation* 2006;81(10):1471-1472; author reply 1472.
15. Papas KK, Hering BJ, Guenther L, Rappel MJ, Colton CK, Avgoustiniatos ES. Pancreas oxygenation is limited during preservation with the two-layer method. *Transplant Proc* 2005;37(8):3501-3504.
16. Kin T, Mirbolooki M, Salehi P, Tsukada M, O'Gorman D, Imes S et al. Islet isolation and transplantation outcomes of pancreas preserved with University of Wisconsin



solution versus two-layer method using preoxygenated perfluorocarbon. *Transplantation* 2006;82(10):1286-1290.

17. Caballero-Corbalan J ET, Foss A, Felldin M, Kallen R, Lundgren T, Salmela K, Tibell A, Tufveson G, Korsgren O. No beneficial effect of the two layer method (PFCUW) compared with transportation in UW alone on the outcome of human islet isolation and transplantation: a report of 214 human pancreases. *American Journal of Transplantation* 2006;6(Suppl 2):340.

18. Caballero-Corbalan J, Eich T, Lundgren T, Foss A, Felldin M, Kallen R et al. No beneficial effect of two-layer storage compared with UW-storage on human islet isolation and transplantation. *Transplantation* 2007;84(7):864-869.

19. Kuhn-Regnier F, Fischer JH, Jeschkeit S, Switkowski R, Bardakcioglu O, Sobottke R et al. Coronary oxygen persufflation combined with HTK cardioplegia prolongs the preservation time in heart transplantation. *Eur J Cardiothorac Surg* 2000;17(1):71-76.

20. Fischer JH, Kuhn-Regnier F, Jeschkeit S, Switkowski R, Bardakcioglu O, Sobottke R et al. Excellent recovery after prolonged heart storage by preservation with coronary oxygen persufflation: orthotopic pig heart transplantations after 14-hr storage. *Transplantation* 1998;66(11):1450-1459.

21. Yotsumoto G, Jeschkeit-Schubbert S, Funcke C, Kuhn-Regnier F, Fischer JH. Total recovery of heart grafts of non-heart-beating donors after 3 hours of hypothermic coronary oxygen persufflation preservation in an orthotopic pig transplantation model. *Transplantation* 2003;75(6):750-756.

22. Tolba RH, Schildberg FA, Schnurr C, Glatzel U, Decker D, Minor T. Reduced liver apoptosis after venous systemic oxygen persufflation in non-heart-beating donors. *J Invest Surg* 2006;19(4):219-227.

23. Saad S, Minor T, Kotting M, Fu ZX, Hagn U, Paul A et al. Extension of ischemic tolerance of porcine livers by cold preservation including postconditioning with gaseous oxygen. *Transplantation* 2001;71(4):498-502.

24. Minor T, Akbar S, Tolba R, Dombrowski F. Cold preservation of fatty liver grafts: prevention of functional and ultrastructural impairments by venous oxygen persufflation. *J Hepatol* 2000;32(1):105-111.

25. Treckmann J, Minor T, Saad S, Ozcelik A, Malago M, Broelsch CE et al. Retrograde oxygen persufflation preservation of human livers: a pilot study. *Liver Transpl* 2008;14(3):358-364.

26. Rolles K, Foreman J, Pegg DE. Preservation of ischemically injured canine kidneys by retrograde oxygen persufflation. *Transplantation* 1984;38(2):102-106.

27. Rolles K, Foreman J, Pegg DE. A pilot clinical study of retrograde oxygen persufflation in renal preservation. *Transplantation* 1989;48(2):339-342.

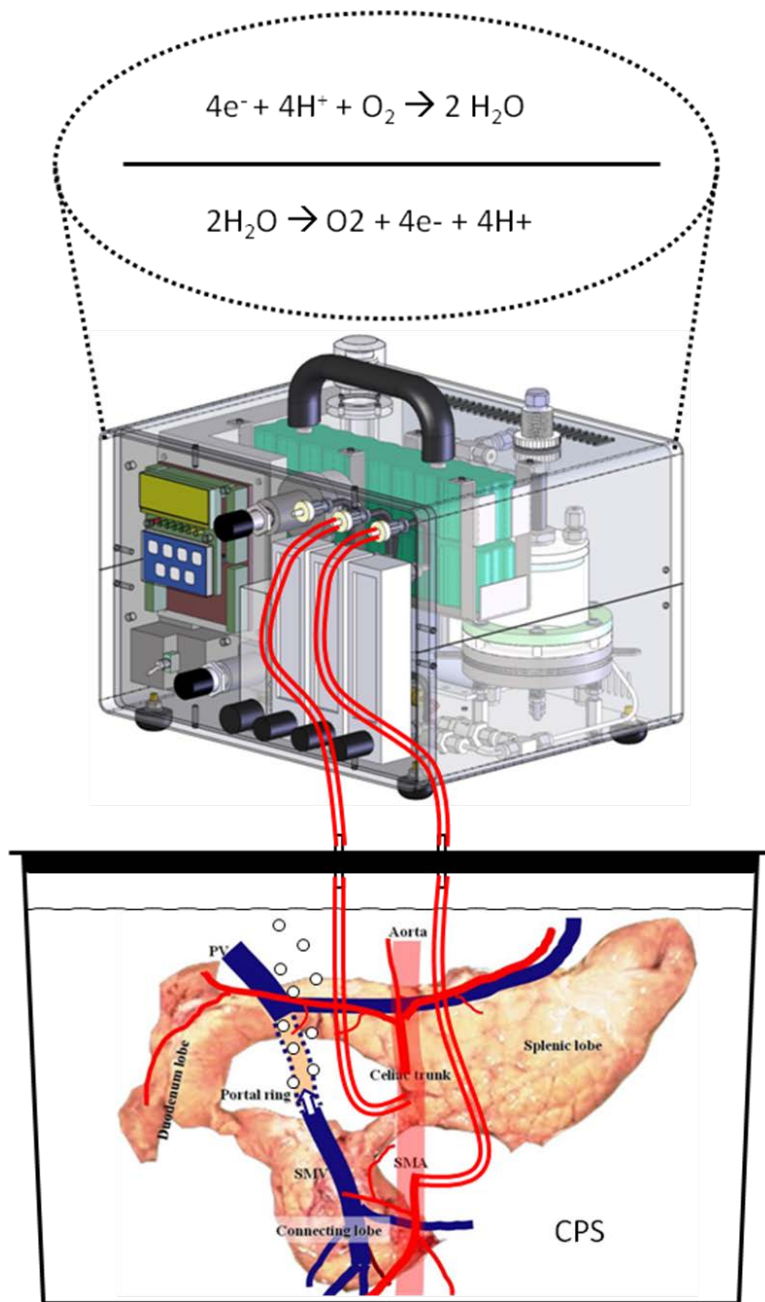
28. Treckmann JW, Paul A, Saad S, Hoffmann J, Waldmann KH, Broelsch CE et al. Primary organ function of warm ischaemically damaged porcine kidneys after retrograde oxygen persufflation. *Nephrol Dial Transplant* 2006;21(7):1803-1808.

29. Minor T, Klauke H, Isselhard W. Improved preservation of the small bowel by luminal gas oxygenation: energetic status during ischemia and functional integrity upon reperfusion. *Transplant Proc* 1997;29(7):2994-2996.

30. Scott WE, 3rd, Weegman BP, Ferrer-Fabrega J, Stein SA, Anazawa T, Kirchner VA et al. Pancreas Oxygen Persufflation Increases ATP Levels as Shown by Nuclear Magnetic Resonance. *Transplant Proc* 2010;42(6):2011-2015.

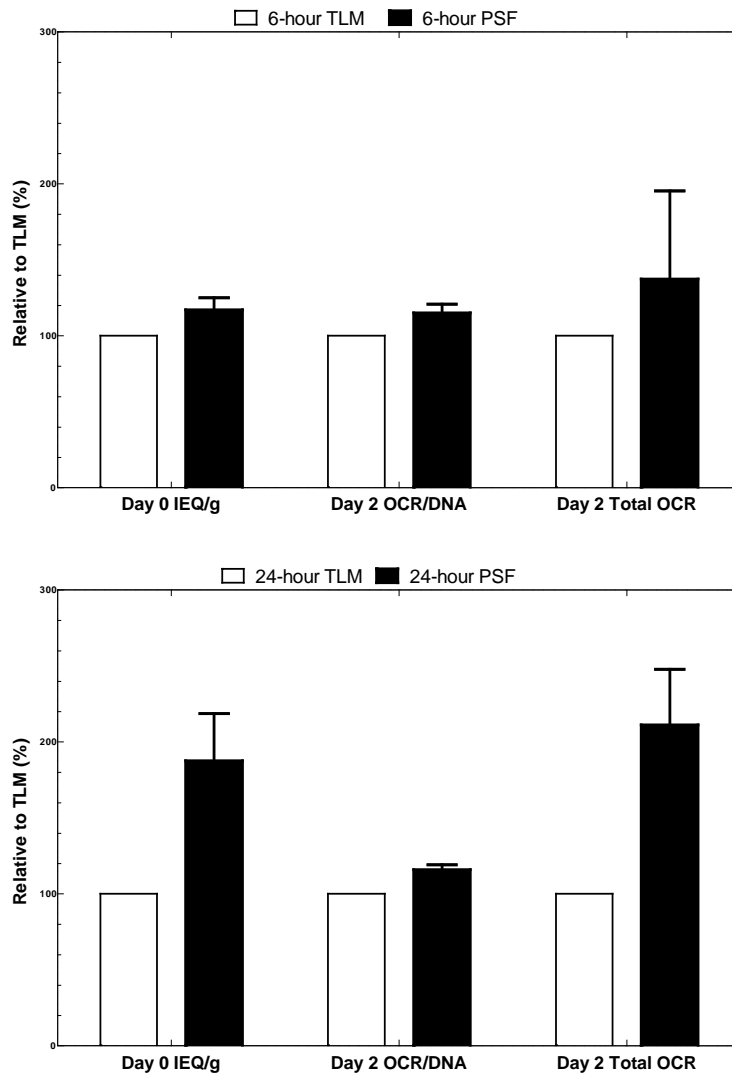
31. Scott WE, 3rd, O'Brien TD, Ferrer-Fabrega J, Avgoustiniatos ES, Weegman BP, Anazawa T et al. Persufflation Improves Pancreas Preservation When Compared With the Two-Layer Method. *Transplant Proc* 2010;42(6):2016-2019.
32. Ferrer J, Scott WE, 3rd, Weegman BP, Suszynski TM, Sutherland DE, Hering BJ et al. Pig pancreas anatomy: implications for pancreas procurement, preservation, and islet isolation. *Transplantation* 2008;86(11):1503-1510.
33. Kuroda Y, Kawamura T, Suzuki Y, Fujiwara H, Yamamoto K, Saitoh Y. A new, simple method for cold storage of the pancreas using perfluorochemical. *Transplantation* 1988;46(3):457-460.
34. Ricordi C, Lacy PE, Scharp DW. Automated islet isolation from human pancreas. *Diabetes* 1989;38 Suppl 1:140-142.
35. Hering BJ, Wijkstrom M, Graham ML, Hardstedt M, Aasheim TC, Jie T et al. Prolonged diabetes reversal after intraportal xenotransplantation of wild-type porcine islets in immunosuppressed nonhuman primates. *Nat Med* 2006;12(3):301-303.
36. Papas KK, Avgoustiniatos ES, Tempelman LA, Weir GC, Colton CK, Pisania A et al. High-density culture of human islets on top of silicone rubber membranes. *Transplant Proc* 2005;37(8):3412-3414.
37. Ricordi C, Gray DW, Hering BJ, Kaufman DB, Warnock GL, Kneteman NM et al. Islet isolation assessment in man and large animals. *Acta Diabetol Lat* 1990;27(3):185-195.
38. Papas KK, Pisania A, Wu H, Weir GC, Colton CK. A stirred microchamber for oxygen consumption rate measurements with pancreatic islets. *Biotechnol Bioeng* 2007;98(5):1071-1082.
39. Papas KK, Colton CK, Nelson RA, Rozak PR, Avgoustiniatos ES, Scott WE, 3rd et al. Human islet oxygen consumption rate and DNA measurements predict diabetes reversal in nude mice. *Am J Transplant* 2007;7(3):707-713.
40. Kim JS, Southard JH. Alteration in cellular calcium and mitochondrial functions in the rat liver during cold preservation. *Transplantation* 1998;65(3):369-375.
41. Anderson CD, Belous A, Pierce J, Nicoud IB, Knox C, Wakata A et al. Mitochondrial calcium uptake regulates cold preservation-induced Bax translocation and early reperfusion apoptosis. *Am J Transplant* 2004;4(3):352-362.
42. Ward JB, Petersen OH, Jenkins SA, Sutton R. Is an elevated concentration of acinar cytosolic free ionised calcium the trigger for acute pancreatitis? *Lancet* 1995;346(8981):1016-1019.
43. Kruger B, Albrecht E, Lerch MM. The role of intracellular calcium signaling in premature protease activation and the onset of pancreatitis. *Am J Pathol* 2000;157(1):43-50.
44. Raraty M, Ward J, Erdemli G, Vaillant C, Neoptolemos JP, Sutton R et al. Calcium-dependent enzyme activation and vacuole formation in the apical granular region of pancreatic acinar cells. *Proc Natl Acad Sci U S A* 2000;97(24):13126-13131.
45. Criddle DN, Murphy J, Fistetto G, Barrow S, Tepikin AV, Neoptolemos JP et al. Fatty acid ethyl esters cause pancreatic calcium toxicity via inositol trisphosphate receptors and loss of ATP synthesis. *Gastroenterology* 2006;130(3):781-793.

## Figures and Tables:



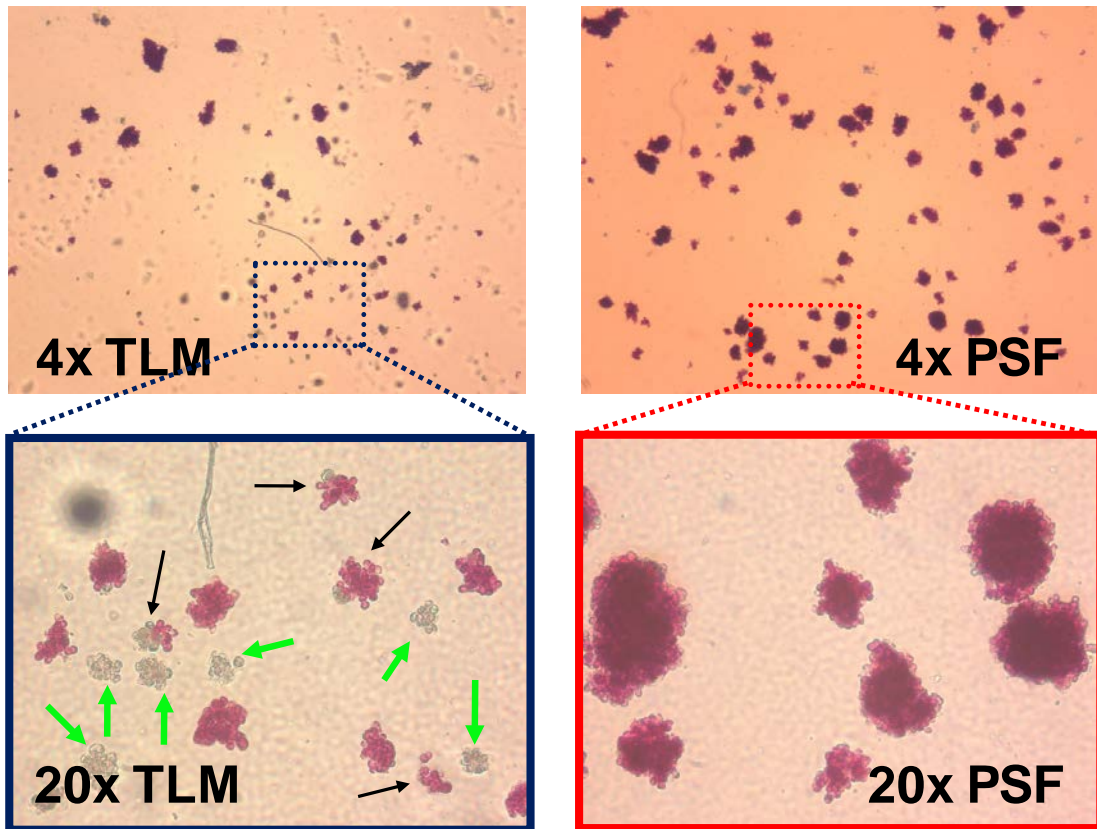
**Figure 7.1:**

Demonstration of how organs were persufflated. The EOC concentrates oxygen via a reaction and dilutes it to the desired concentration. This gas mixture is then delivered via gas impermeable tubes to the celiac trunk and superior mesenteric artery where it is then delivered into the pancreas and exits from the portal vein.



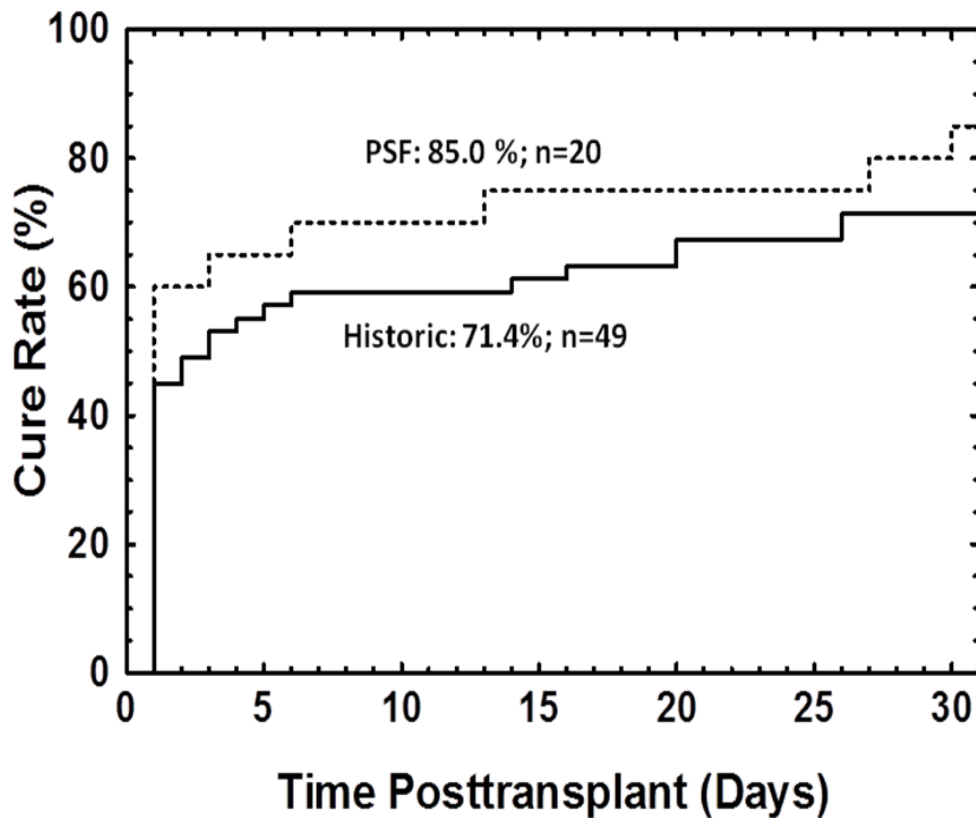
**Figure 7.2:**

Day 0 IE yield, day 2 OCR/DNA, and day 2 OCR yield from the splenic lobe persufflated for 6 (n=4) or 24 (n=8) hours are shown relative to paired lobes preserved with TLM for the same time periods. PSF was superior for all key preservation outcomes. Statistical significance was achieved for all outcomes following 24 hours preservation ( $p < 0.05$ , paired 2-tailed Student's t-test). Day 2 OCR/DNA exhibited a modest improvement with PSF (~15% for 6-hour, ~16% for 24-hour preservation) which was however very consistent among organs.



**Figure 7.3:**

Photomicrographs of dithizone-stained islets isolated from paired porcine pancreatic lobes after 24 hours of preservation with the TLM or PSF. Samples were obtained from pooled islet preparations and imaged at 4x and 20x magnification. TLM islet preparations exhibited smaller, more fragmented islets (black arrows) with more acinar impurities (green arrows) when compared with paired PSF preparations.



**Figure 7.4:**

Kaplan-Meier plots of diabetic nude mice transplanted with 2,000 islet equivalents (IE) under the kidney capsule. Islets transplanted from preparations exposed to 6 or 24 hours PSF (n=20) compared favorably to historic controls (n=49) with no significant difference between the 2 groups observed. Diabetes reversal was defined as blood glucose levels below 200 mg/dL for 2 consecutive days after an initial recovery period of 2 days posttransplant. The DR time was defined by convention as the first day of the period during which the DR criteria were satisfied (hence the DR times during the first 2 days posttransplant).

24 hr preservation - Day 0	Units	PSF	TLM	PSF/TLM	p-value
OCR/DNA	nmol/(min·mg DNA)	128±12	104±6	1.25±0.13	0.12
Morphology Score	arbitrary	6.69±0.41	6.13±0.52	1.12±0.07	0.047*
Islet Equivalents:Islet Number		0.514±0.094	0.384±0.066	1.36±0.15	0.046*
Islet Diameter	µm	117±8	106±6	1.10±0.04	0.045*
IE per gram Digested Tissue	IE/g	1040±273	686±211	1.88±0.31	0.025*
DNA-IE per gram Digested Tissue	IE/g	853±225	634±178	1.47±0.17	0.030*
Total OCR per gram Digested Tissue	nmol/(min·g Tissue)	1.52±0.37	0.894±0.212	1.73±0.19	0.013*
Undigested Tissue	%	31.0±5.1	29.9±4.8	1.16±0.18	0.39
Islet Purity	%	90.7±0.7	91.4±0.9	0.99±0.01	0.63

24 hr preservation - Day 2	Units	PSF	TLM	PSF/TLM	p-value
OCR/DNA	nmol/(min·mg DNA)	203±16	174±10	1.16±0.03	4.9 x 10 <sup>-3</sup> **
Morphology Score	arbitrary	6.14±0.30	5.50±0.41	1.12±0.06	0.13
Islet Equivalents:Islet Number		0.427±0.050	0.357±0.063	1.27±0.13	0.072†
Islet Diameter	µm	112±5	105±6	1.08±0.03	0.067†
IE per gram Digested Tissue	IE/g	431±178	284±163	2.95±0.92	0.088†
DNA-IE per gram Digested Tissue	IE/g	742±251	460±189	1.84±0.29	0.034*
Total OCR per gram Digested Tissue	nmol/(min·g Tissue)	1.77±0.58	1.02±0.43	2.11±0.37	0.038*
Islet Count Recovery	%	58.5±9.8	46.1±10.2	1.77±0.48	0.17
Islet DNA Recovery	%	73.6±10.0	62.3±11.9	1.37±0.22	0.20

**Table 7.1:**

Summary of all assays performed comparing islet number and quality following 24 hours of persufflation (PSF) or preservation with the two-layer method (TLM). \*\* highly statistically significant ( $0.001 < p < 0.01$ ); \* statistically significant ( $0.01 < p < 0.05$ ); † trend towards statistical significance ( $0.05 < p < 0.10$ ).

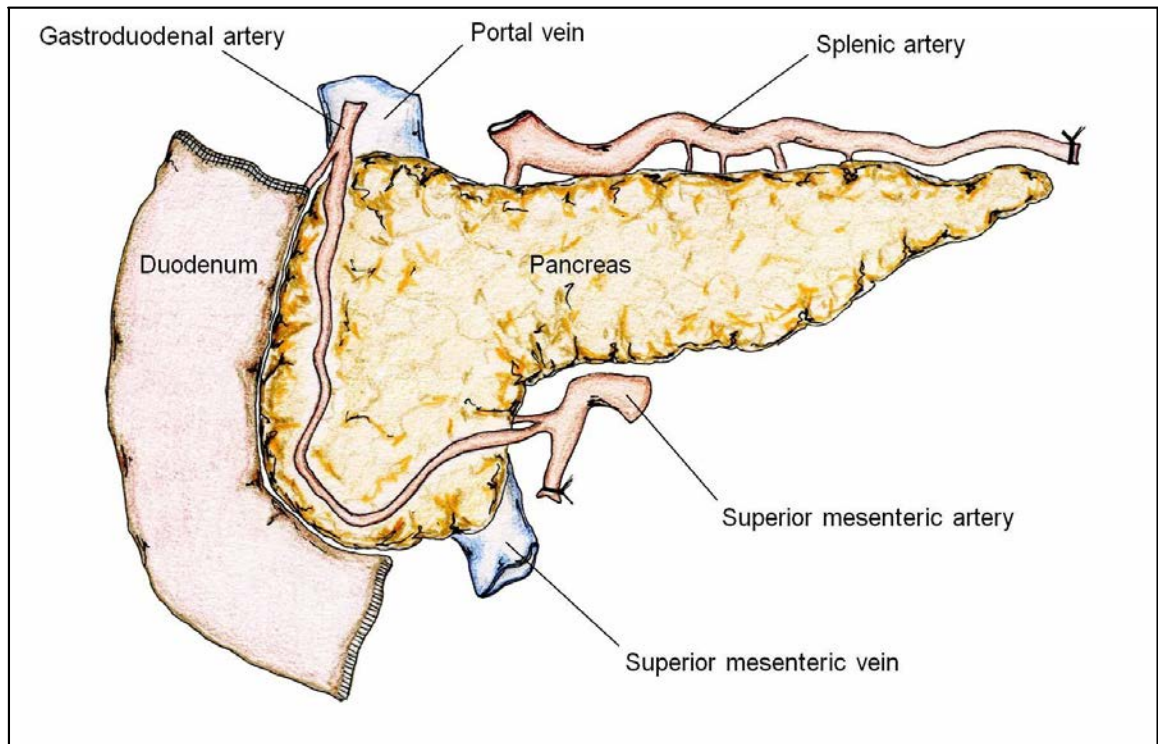


## **Oxygen Persufflation can Extend Human Pancreas Preservation Time from 10 to 24 Hours while Maintaining Viable Islet Yield and Quality**

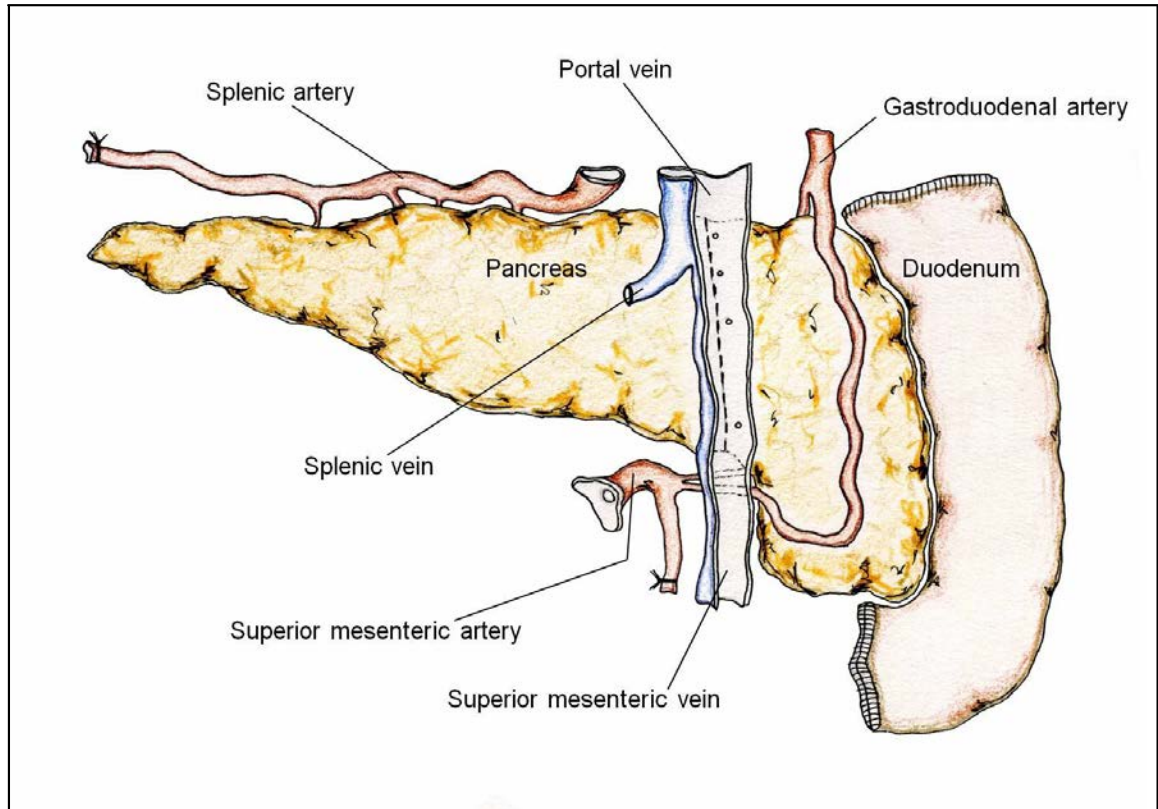
Following up on the exciting porcine pancreas preservation studies presented in the previous section, a study investigating a split human pancreas preservation model has been initiated. 3 human pancreata were procured and split on the operating room back table according to the protocol prepared with the help of Tomas Suszynski and presented as follows.

## **Surgical Procurement:**

Following cardiac arrest, the donor intraperitoneal cavity is accessed via midsagittal or cruciate laparotomy. A nasogastric tube is advanced past the pylorus and the duodenum is flushed with antimicrobial solution. Surgical pancreatectomy should be performed rapidly while preserving the major vascular supply to the pancreas. Following supraceliac crossclamp of the aorta and infrarenal aortic flush, the pancreas will be mobilized from all retroperitoneal attachments – with care taken to preserve the gastroduodenal, splenic and superior mesenteric arteries (including all pancreatic branches). Once the pancreas is mobilized, the gastroduodenal artery should be divided proximal to the pancreas. The splenic artery can be divided proximally (near the celiac axis) and ligated distally (distal to the tail of the pancreas). If the celiac axis is not taken with the liver, the proximal splenic artery does not need to be divided and the celiac trunk can be preserved and taken with the pancreas. The superior mesenteric artery should be ligated distal relative to the head and uncinate parts of the pancreas – with care to ensure pancreatic branches remain intact. The portal, superior mesenteric and splenic veins can be divided around the pancreas. A Kocher maneuver can be used to access the caudal surface of the head of the pancreas and to mobilize the duodenum. The first and third parts of the duodenum can be stapled across using a gastrointestinal anastomosis (GIA) stapler. **Figures 7.5** and **7.6** illustrate the surgically procured human pancreas along with intact vessels.

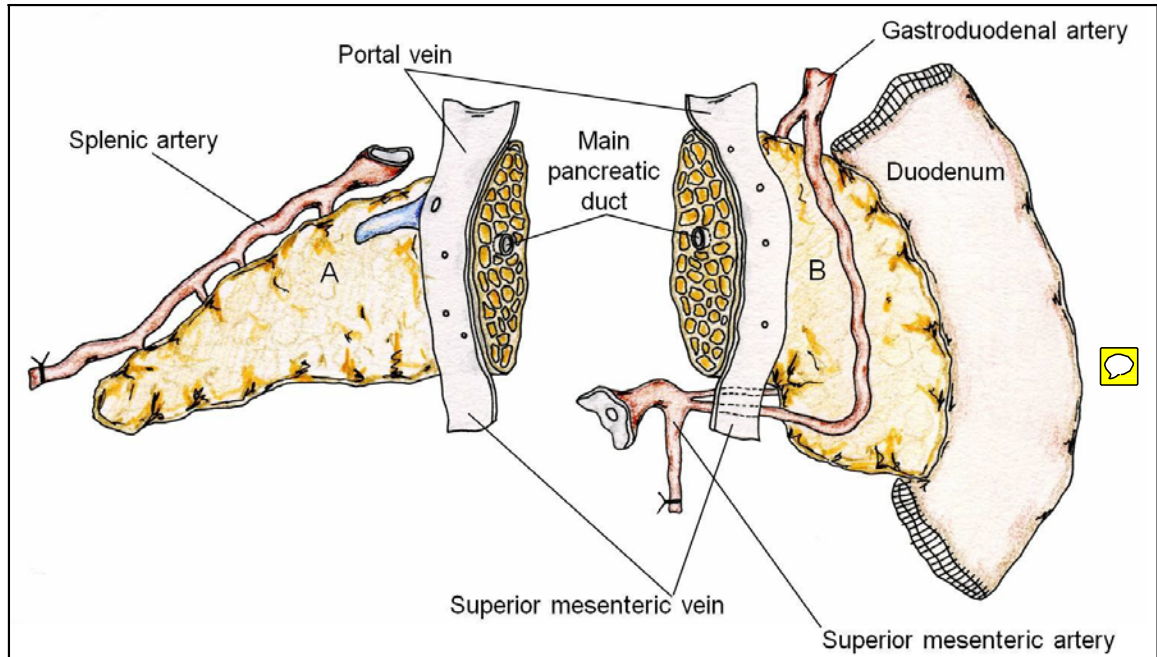


**Figure 7.5:** Anterior view of surgically procured human pancreas. Note the vessels that remain preserved, including the splenic artery (including all major pancreatic branches), the gastroduodenal and proximal superior mesenteric arteries (including all pancreaticoduodenal vessels and anastomoses).



**Figure 7.6:** Posterior view of surgically procured human pancreas. In this schematic the portal and superior mesenteric veins are divided longitudinally to expose the line (dotted) along which the pancreas will be divided into two segments.

At the back table, the portal and superior mesenteric veins (caudal to the pancreas) are divided along their longitudinal axes – this division represents the line along which the pancreas can be divided into two segments. **Figure 7.7** illustrates the segmented human pancreas.



**Figure 7.7:** Posterior view of the segmented human pancreas. Segment A represents the body and tail, and Segment B primarily represents the head and uncinus process of the pancreas. For islet isolation – the main pancreatic ducts can be accessed from the cut edges of each segment.

If the pancreas is to be segmented, it can be divided using a GIA stapler or by cutting across with a scalpel. If the latter is used, the segment allocated for persufflation needs to be sealed by clamping the cut edge with an atraumatic clamp, running a stitch and oversewing.

If Segment A (shown in **Figure 7.7**) has been allocated for preservation via persufflation (gas perfusion), the proximal splenic artery or the celiac trunk should be directly cannulated. If Segment B (shown in **Figure 7.7**) has been allocated for preservation via persufflation, either one or both of the superior mesenteric and

gastroduodenal arteries can be cannulated. If only one is chosen for cannulation, the other can be ligated away from the pancreas. Whole pancreas persufflation is also possible by cannulating the splenic artery or celiac trunk and the superior mesenteric or gastroduodenal artery or both.

### **Persufflation:**

Following cannulation, each vascular access point designated for persufflation should be tested for gross leaks by hand infusion of 60-mL of preservation solution, and any leaks that are found should be ligated. Cannulated vessels should be persufflated by connecting to the electronic oxygen concentrator (persufflator). The pressure should then be raised by adjusting the individual flow channels until a sustainable flow rate of 20 mL/min is reached for each channel<sup>7</sup>. Any arterial gas leaks (small rapid bubbling) should then be identified and ligated with surgical ties. All leaks should be tied until venous outflow can be observed (large slow bubbling from the vein)<sup>8</sup>.

At this stage, the whole pancreas or the segment allocated for persufflation should be placed into the custom- built persufflation container, connected through the lid to the

---

<sup>7</sup>This may require someone to manipulate the persufflator to maintain flow to each vascular access point as the resistances can change dramatically as leaks are tied off. Typical pressures required to drive adequate flow can vary within an acceptable range (10-30 mm Hg). Pressures may exceed the acceptable range during leak testing and brief periods of elevated pressure may be necessary during this period.

<sup>8</sup>It may be difficult to seal all arterial leaks. If this is the case, it is acceptable for minor arterial leaks to remain as long as venous bubbles can be identified exiting the pancreas. Another indication that the pancreas or segment is persufflating would be that it begins to float in the preservation solution.

persufflator and prepared for transport. The pressure and flow should be adjusted so that each vascular access point receives an approximate gas flow rate of 20 mL/min at the minimum pressure possible and this pressure recorded; minimization of pressures may require that the whole pancreas or segment be repositioned within the container – as often times the vessels or the tubing can kink and occlude gas flow, and cause a transient increase in persufflation pressure. The pressure and individual flow rates should be checked intermittently over the first 30-60 min of persufflation as the pressure required to drive flow typically drops during this period.

Following procurement, segments were then preserved for either 10 hours of TLM or 24 hours of PSF and transported (by plane or car) back at the University of Minnesota.

Initial outcomes are very encouraging with all pure islet fraction quality and quantity indices examined similar or better on the day of isolation for 24 hours PSF relative to 10-hours TLM (**Table 7.2**).

	n	Mean±SEM		
		TLM Lobe	PSF Lobe	Paired Ratio PSF/TLM
Cold Preservation Time (hr)	3	9.87 ± 0.40	24.11 ± 0.20	2.45 ± 0.11
Tissue Weight (g)	3	48.1 ± 9.7	53.7 ± 2.9	1.18 ± 0.16
Undigested Tissue (%)	3	33.2 ± 9.1	36.0 ± 14.0	1.02 ± 0.16
Islet Purity (%)	3	68.3 ± 4.4	75.0 ± 8.7	1.12 ± 0.20
Islet Morphology Score (10)	3	8.8 ± 0.2	9.3 ± 0.3	1.06 ± 0.03
Islet Yield (IE)	3	85,029 ± 26,853	210,557 ± 46,004	3.36 ± 1.57
Islet Yield (IE/g)	3	1,784 ± 596	3,967 ± 888	2.67 ± 1.03
OCR/DNA (nmol/min/mg DNA)	3	111.0 ± 6.2	112.8 ± 17.9	1.01 ± 0.11
Islet OCR Yield (nmol/min)	3	96.0 ± 29.6	253.8 ± 70.0	3.71 ± 2.06
Islet OCR Yield (nmol/min/g)	3	2.05 ± 0.70	4.85 ± 1.47	2.90 ± 1.41
Insulin Staining (% Area)	2	28.5 ± 22.3	42.0 ± 5.9	3.39 ± 2.44
β-Cell OCR Yield (nmol/min)	2	34.0 ± 20.5	96.9 ± 2.8	4.41 ± 2.58
β-Cell OCR Yield (nmol/min/g)	2	0.60 ± 0.22	1.85 ± 0.12	3.62 ± 1.50

**Table 7.2:**

Key outcomes for pure islet fractions obtained on the day of isolation from paired pancreatic segments preserved by either persufflation for 24 hours or the two-layer method for 10 hours.

Statistical analysis of these data is pending more replicates but the data so far would seem to imply that PSF, by enhancing oxygenation and maintaining ATP levels, can extend human pancreas preservation time to 24 hours while maintaining and possibly even improving islet isolation outcomes, including viable islet yield.



## Chapter 8: Persufflation: Device Considerations

In addition to assessing the efficacy of PSF for organ preservation; much work was done in aiding the engineers at Giner Inc (Newton, MA) in the design of the electrochemical oxygen concentrator (EOC) used for PSF or 'Persufflator'. A brief history of Persufflator device design is provided.

When I began work on PSF; a gas cylinder was needed to provide gas for PSF (**Figure 8.1**).



**Figure 8.1:**

Example of gas cylinder in use for early pancreas persufflation work.

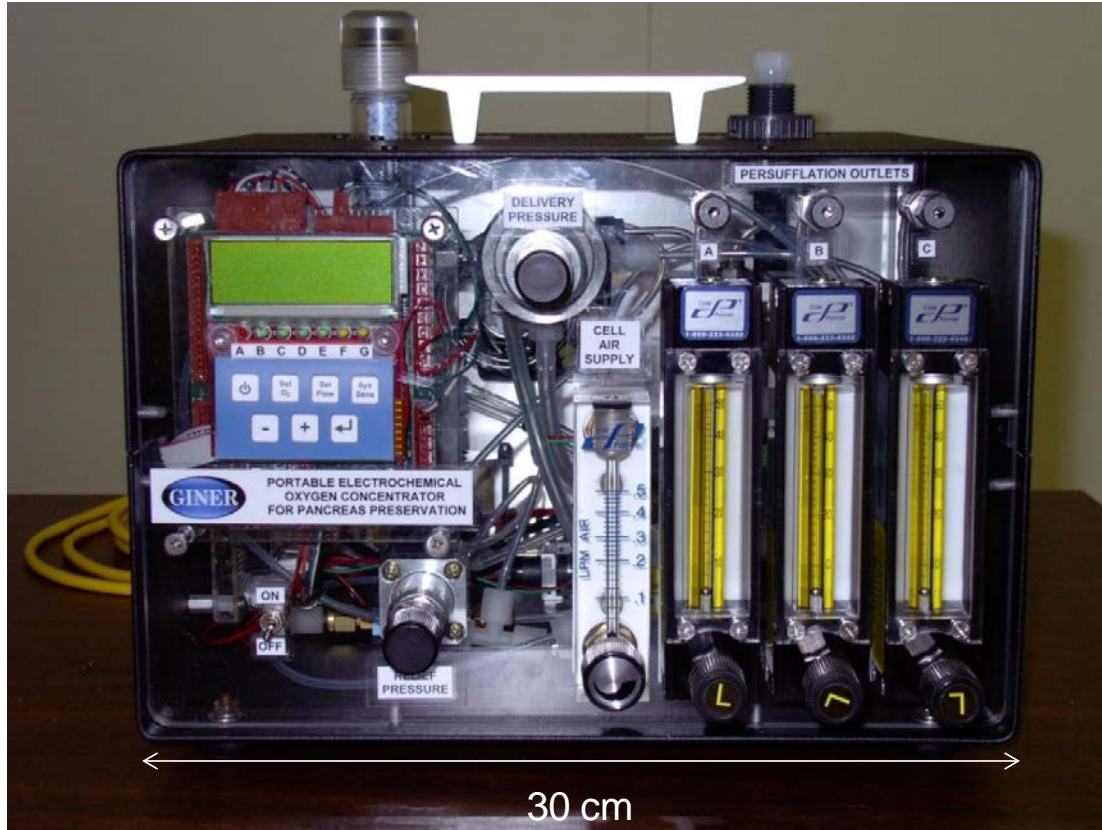
This was followed up by an initial EOC design (EOC v1; **Figure 8.2**) which consisted of a manifold for controlling delivery pressures and an EOC which required manual control of current and air diluents to achieve a given concentration. This iteration had no included battery and so a portable power source had to be brought with the device for any desired transport but is notable as the first device which could provide oxygen at a desired flow rate, pressure and concentration to organs without the use of gas cylinders.



**Figure 8.2:**

EOC v1; the manifold is at the top left while the device itself is on the top right.

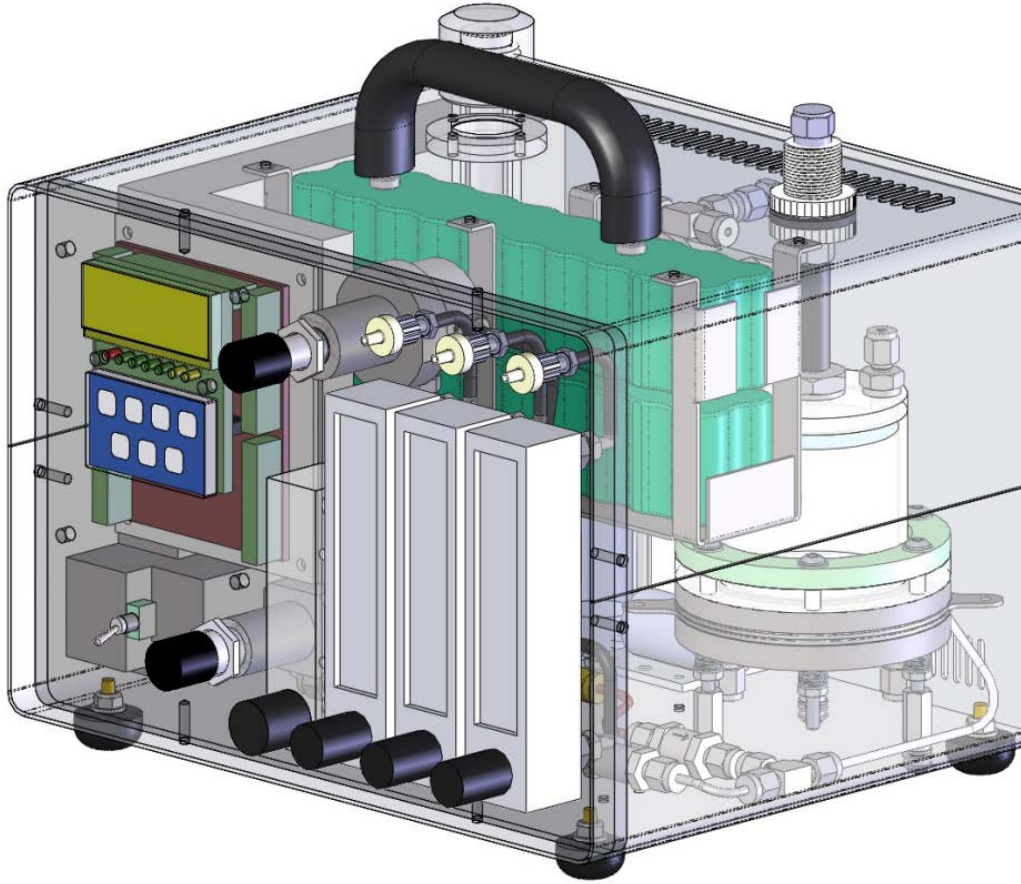
This design was then followed up by a more integrated and portable design (EOC v2; **Figure 8.3**). This device combined the manifold and pressure control into a single cube-shaped device of approximately 30 cm on a side. This design incorporated a digital panel for setting oxygen concentration and monitoring delivery pressures. An external battery was attached via a cable, providing an included power supply which could last for as long as 7 hours of continuous use. These changes improved the portability of the device dramatically enabling PSF in flight. However, the tiny handles and external nature of the battery prevented the device from being easily transported by a single person; requiring 2 people to carry it through typically unfamiliar hospital corridors to the operating room back table for use.



**Figure 8.3:**

EOC v2; the first integrated device providing oxygen supply with fine control of delivery pressure, flow rate and concentration.

The limitations of this design led to the development of the presently used design; EOC v3. In this design, the battery was integrated into the main case and a more ergonomic handle included for enhanced transport. A cartoon representation of this iteration supplied by Giner Inc. has been included in **Figure 8.4**.



**Figure 8.4:**

Schematic cartoon representation of EOC v3. This shows how the battery was integrated into the case beneath the handle assembly.

A new generation of Persufflator is presently in development. This new device preliminarily names the 'P3S' system. This system will integrate the EOC device and manifold into a cooler eliminating the need for a separate cooler with tubing ported through its lid. This will be a further leap forward in portability and will hopefully be ready for use in the near future.

A patent application which I am a co-inventor on 'Perfusing an organ with in situ generated gas' (US2010/0330547 A1) has been filed with the United States Patent and Trademark Office and is presently 'pending'.

## **Chapter 9: Other Methods to Monitor Organ Viability by Whole Organ Oxygen Consumption Rate (WO-OCR)**

In addition to the  $^{31}\text{P}$ -NMR spectroscopy method for non-invasively monitoring ATP levels presented earlier; it is important to develop other minimally invasive methods to assess organs prior to transplantation. One such method based on monitoring oxygen consumption normalized to tissue mass is presented in the original manuscript: **BP Weegman, VA Kirchner, WE Scott III, ES Avgoustiniatos, TM Suszynski, J Ferrer-Fabrega, MD Rizzari, LS Kidder, R Kandaswamy, DER Sutherland, KK Papas: Continuous, Real-time Viability Assessment of Kidneys Based on Oxygen Consumption; Transplantation Proceedings, 2010 Jul-Aug;42(6):2020-3.** included with the permission of the publisher of the journal 'Transplantation Proceedings', Elsevier (Appendix 9).

My contributions to this work include in depth involvement in development of the technique; as well as help in data collection and discussion.

**Title:**

Continuous Real-time Viability Assessment of Kidneys Based on Oxygen Consumption

9

**Authors:**

B.P. Weegman, V.A. Kirchner, W.E. Scott III, E.S. Avgoustiniatos, T.M. Suszynski, J. Ferrer-Fabrega, M.D. Rizzari, L.S. Kidder, R. Kandaswamy, D.E.R. Sutherland, and K.K. Papas

From the Schulze Diabetes Institute (B.P.W., V.A.K., W.E.S., E.S.A., T.M.S., J.F.-F., M.D.R., L.S.K., D.E.R.S., K.K.P.), Department of Surgery (R.K.), University of Minnesota, Minneapolis, Minnesota; and the University of Texas Southwestern Medical Center Department of Surgery (M.D.R.), Dallas, Texas.

---

<sup>9</sup>Supported by grants from the National Institutes of Health National Institute of Diabetes and Digestive and Kidney Diseases (R43 DK070400), the Schott Foundation, the Carol Olson Memorial Diabetes Research Fund, the United Metal Traders, the Eunice L. Dwan Trust, the Iacocca Family Foundation, and Tom and Meredith Olson.

The authors thank Mike Taylor, Simona Baicu, Mike Loughnane, Kristen Maynard, Brian Perrault, Mel Graham, Luke Mutch, Takayuki Anazawa, Ichiro Matsumoto, and Ron Joki for administrative and scientific support.

Address reprint requests to K.K. Papas, PhD, Schulze Diabetes Institute, Department of Surgery, University of Minnesota, 424 Harvard St. SE, Rm. 421 Minneapolis, MN 55455. E-mail: papas006@umn.edu



**Background.** Current *ex vivo* quality assessment of donor kidneys is limited to vascular resistance measurements and histological analysis. New techniques for the assessment of organ quality before transplantation may further improve clinical outcomes while expanding the depleted deceased-donor pool. We propose the measurement of whole organ oxygen consumption rate (WOOCR) as a method to assess the quality of kidneys in real time before transplantation.

**Methods.** Five porcine kidneys were procured using a donation after cardiac death (DCD) model. The renal artery and renal vein were cannulated and the kidney connected to a custom-made hypothermic machine perfusion (HMP) system equipped with an inline oxygenator and fiber-optic oxygen sensors. Kidneys were perfused at 8 °C, and the perfusion parameters and partial oxygen pressures (pO<sub>2</sub>) were measured to calculate WOOCR.

**Results.** Without an inline oxygenator, the pO<sub>2</sub> of the perfusion solution at the arterial inlet and venous outlet diminished to near 0 within minutes. However, once adequate oxygenation was provided, a significant pO<sub>2</sub> difference was observed and used to calculate the WOOCR. The WOOCR was consistently measured from presumably healthy kidneys, and results suggest that it can be used to differentiate between healthy and purposely damaged organs.

**Conclusions.** Custom-made HMP systems equipped with an oxygenator and inline oxygen sensors can be applied for WOOCR measurements. We suggest that WOOCR is a promising approach for the real-time quality assessment of kidneys and other organs during preservation before transplantation.

**Introduction:**

Renal transplantation is the definitive therapy for patients with end-stage renal disease, offering increased longevity and improved quality of life [1]. At present, one of the main challenges in the field of transplantation is that demand for donor organs far exceeds the available supply. To address this disparity, the field has promoted programs for living donation, the use of organs from expanded criteria donors, and donation after cardiac death (DCD) [1]. As an increasing number of marginal organs are used, organ-quality assessment before transplantation has emerged as an important and urgent issue.

Current *ex vivo* quality assessment tools for donor kidneys are limited to histologic analysis [2] and measurement of vascular resistance during perfusion [3]. The development of new real-time quantitative techniques for the assessment of organ quality *ex vivo* may potentially expand the donor kidney pool. We present herein a technique for the continuous noninvasive measurement of whole organ oxygen consumption rate (WOOCR) as a method to assess the quality of organs during preservation and before transplantation. In addition to excluding organs that are unsuitable for transplantation, this method could allow for identification of healthy organs that would have otherwise been rejected as unsuitable.

Under normal physiologic conditions most viable tissues consume oxygen [4]. Consequently, determining WOOCR could be useful for quantifying organ viability even when measurements are conducted during cold preservation (4–8 °C). Calculation of oxygen consumption rate (OCR) has been applied before in the study of the heart [5], the

liver [6], and the kidney [7-9]. It has also been shown that OCR is a reliable and useful measure of pancreatic islet quality and can be used to predict islet transplant outcome [10-12].

We present WOOCR as a method for use with a modified hypothermic machine perfusion (HMP) system. HMP has been shown to be an effective method of organ preservation and is becoming a standard of clinical practice for kidney preservation among organ procurement organizations [13]. Current clinical prototypes of HMP do not include oxygen sensors or an adequate oxygenation system to meet the oxygen demand of a viable kidney, even at cold temperatures. We propose 2 simple modifications to currently available clinical perfusion devices, including: 1) an inline oxygenator with oxygen supply; and 2) inline fiber-optic oxygen sensors, which are added to the HMP system without disturbing the organ. This setup provides the kidney with oxygenated perfusate and allows for real-time measurement of WOOCR.

## **Methods:**

### **Porcine Kidney Procurement**

5 porcine kidneys were procured from non-heart-beating donors (NHBDs). Each animal received an intravenous injection of 50,000-100,000 U heparin and was sacrificed using a lethal injection of pentobarbital sodium. Following exsanguination, the donor animals were eviscerated and the posterior wall of the aorta was incised longitudinally to expose the ostium of the renal artery (RA). RAs were individually cannulated, and each kidney

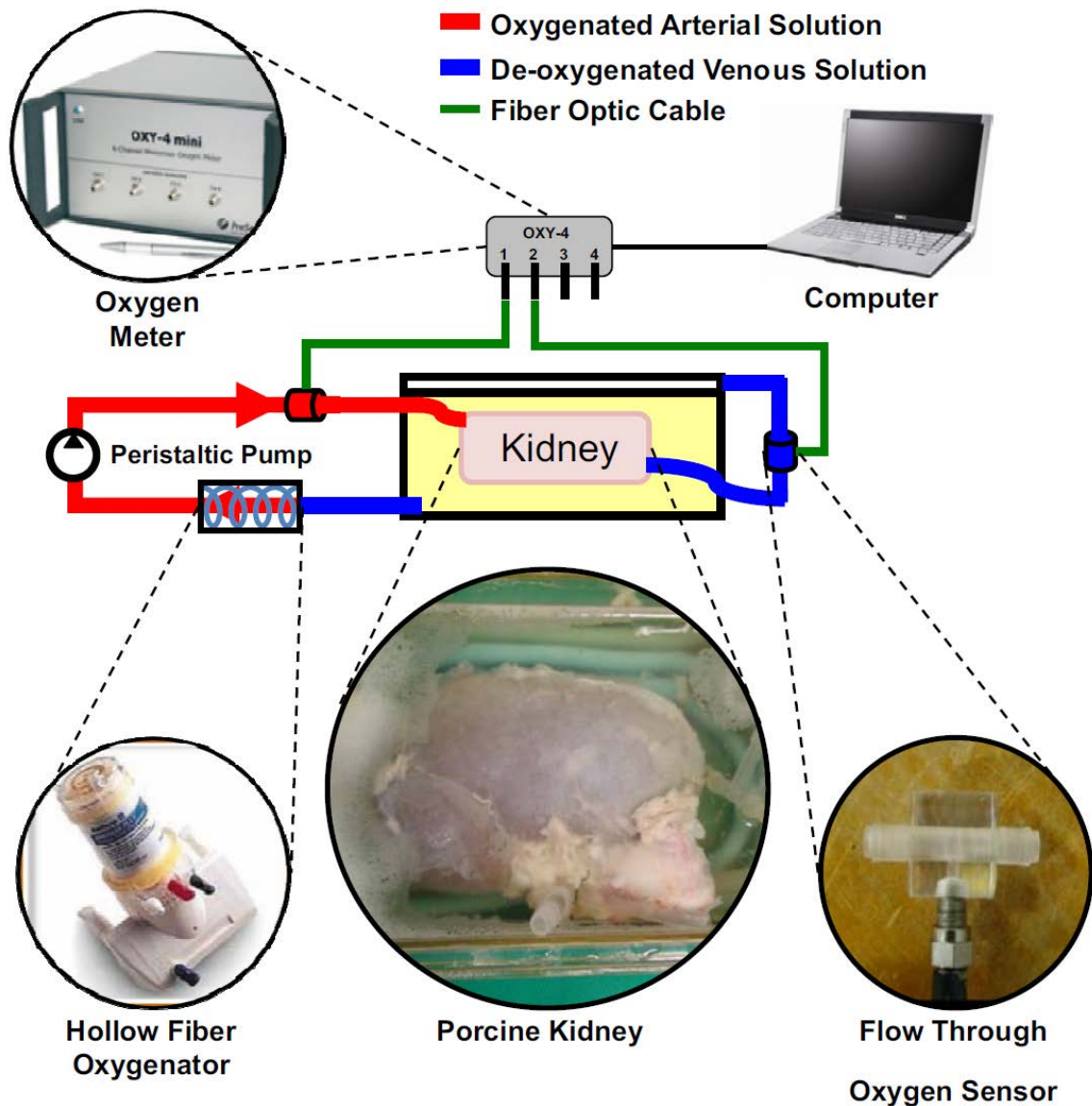
was flushed with 1 L cold lactated Ringer solution (LRS) and carefully dissected away from the viscera. Warm ischemia time was minimized to <10 minutes during the procurement. Each kidney was weighed after procurement and before HMP.

### **Hypothermic Machine Perfusion and WOOCR Setup**

Arterial and venous ends of each organ were cannulated and connected to the HMP system. In our custom-built HMP system, 2 fiber-optic oxygen sensors (Instech Labs, Plymouth Meeting, PA) were placed inline upstream of the RA and 2 placed downstream of the renal vein (RV) for the measurement of arterial and venous partial oxygen pressure ( $pO_2$ ), respectively. To provide maximum oxygenation without causing vascular damage, the flow rate was controlled to be 100–200 mL/min and the temperature maintained at 8 °C for the duration of the perfusion. The WOOCR of a kidney was calculated using a mass balance equation where  $Q$  is the flow rate of perfusion (mL/min),  $\alpha$  is the solubility of oxygen at a given temperature (mol/mL•mm Hg), and  $m$  is the mass of the kidney (g).

$$OCR = \frac{Q \times (pO_{2_{Arterial}} - pO_{2_{Venous}}) \times \alpha}{m}$$

During perfusion of 4 kidneys, an oxygenator was incorporated into the setup to provide a steady supply of oxygenated preservation solution to the organ. **Figure 9.1** shows the basic setup of the HMP system with inline fiber-optic oxygen sensors and the oxygenator.



**Figure 9.1:**

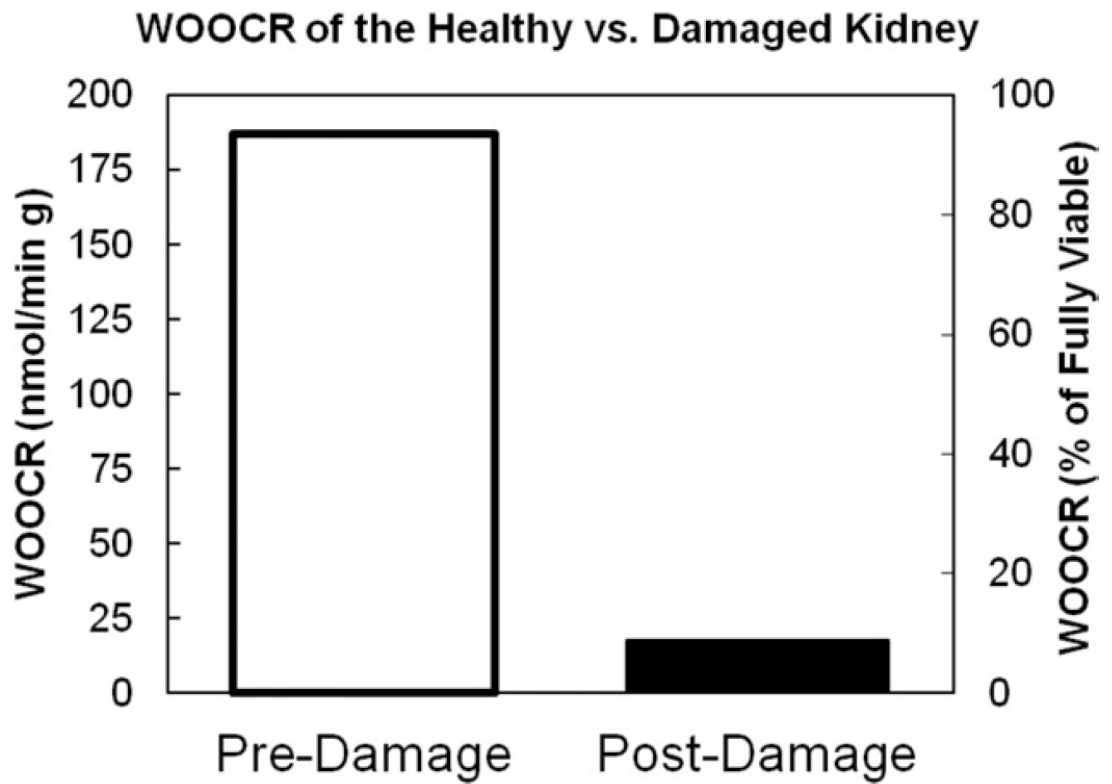
Simple OCR perfusion system schematic, illustrating the perfusion circuit containing the inline oxygenator and oxygen sensors.

### **Formalin Treatment of the Porcine Kidney**

After a single porcine kidney was harvested and flushed with 1 L cold LRS, the initial measurement was performed to establish WOO CR before formalin treatment. Next, the kidney was flushed with 120 mL 10% buffered formalin through the RA, followed by a flush with 120 mL LRS to remove any remaining formalin. The new set of WOO CR data was collected 30 minutes after the formalin treatment.

### **Results:**

As expected, without an oxygenator the measured  $pO_2$  of the perfusate for both the RA and the RV approached zero within minutes while perfusing at 100 mL/min at 8 °C. After incorporating an inline oxygenator, the inlet (RA)  $pO_2$  was maintained at ~150 mm Hg (in equilibrium with room air), but the outlet (RV)  $pO_2$  still remained near zero. When the arterial  $pO_2$  was elevated to >300 mm Hg (using an oxygen supply), the outlet  $pO_2$  increased and a significant  $pO_2$  drop that was not limited by the oxygen supply was measured between the RA and RV for every kidney. The average WOO CR for presumably healthy kidneys on HMP with an inline oxygenator was  $158 \pm 62$  nmol/min/g ( $n = 4$ ; range 92–229 nmol/min/g). These results (and our theoretical calculations) verify the requirement of an inline oxygenator to provide an inlet  $pO_2$  of >300 mm Hg for the adequate oxygenation of the entire organ and for the accurate measurement of WOO CR for the average porcine kidney. A dramatic drop in the WOO CR of the kidney after the formalin insult (17 nmol/min/g) was compared with the WOO CR of the same organ before formalin treatment (187 nmol/min/g; **Figure 9.2**). These results suggest that WOO CR can differentiate between damaged and healthy organs.



**Figure 9.2:**

WOOCR measurements from a single kidney immediately after the procurement and 30 minutes after formalin flush.

**Discussion:**

Current clinical HMP systems are not equipped with oxygenators. Rapid depletion of oxygen from the reservoir containing nonoxygenated preservation solution subjects the organ to hypoxic conditions. A theoretical calculation demonstrates that 1 L LRS equilibrated with air would be depleted of its oxygen content in ~5 minutes by an average “healthy” adult porcine kidney undergoing HMP. The experimental results confirm that arterial and venous  $pO_2$  values of the recycled perfusate (ie, nonoxygenated) decreased to near zero after a few minutes of perfusion at 8 °C. The results of this limited study clearly support the need for improved oxygen delivery in HMP systems during kidney preservation. One solution is to use an inline oxygenator which can supply a  $pO_2$  of  $\leq 300$  mm Hg. Using a perfusion solution with a higher oxygen solubility could also improve oxygenation of tissue using a lower  $pO_2$ .

With adequate oxygenation, a significant  $pO_2$  drop that was not limited by the oxygen supply (ie, RV  $pO_2$  was significantly  $>0$ ) was observed between the RA and RV of every organ, and an average WOOOCR value of presumably healthy kidneys on HMP was measured at 158 nmol/min/g. This value was similar to the OCR of healthy pancreatic tissue at 8 °C (200 nmol/min/g) [10].

Our results also indicated a significant variability in WOOOCR among freshly procured kidneys (range 92–229 nmol/min/g) that were harvested using our standardized technique. We hypothesize that the variability in WOOOCR among these organ can be



correlated with the individual organ quality and may identify damaged organs *ex vivo* that otherwise would be undetected.

The difference between the WOOCR in presumably healthy and damaged organs was supported by comparing the WOOCR of a formalin-treated (damaged) kidney (17 nmol/min/g) to the WOOCR of the same organ before treatment (187 nmol/min/g) or the average WOOCR of all 4 untreated organs (158 nmol/min/g). Detection of any WOOCR in the formalin-treated kidney suggests the incomplete damage of the organ and reflects the OCR of the remaining viable tissue. The WOOCR of the kidney would be expected to approach zero if the amount of fixate and the duration of the fixation were increased.

Based on these data, we conclude that a real-time noninvasive method for the measurement of WOOCR in conjunction with oxygenated HMP may be used to assess organ quality *ex vivo*. These measurements are feasible using a modified clinical prototype of HMP system.

The role of oxygenation in organ preservation remains controversial [6, 14, 15]. The optimum HMP preservation will need to balance the potential damage that can occur with the generation of free radicals with the necessity to provide sufficient oxygen to sustain healthy tissues. Our future research will be directed toward further validation of the WOOCR method by correlating measurements to histologic data, molecular profiles, and graft function after allogeneic transplantation in a large animal model.

**References:**

1. Knoll G: Trends in kidney transplantation over the past decade. *Drugs*, 68 (Suppl 1), pp. 3–10 (2008)
2. Reznik ON, Bagnenko SF, Loginov IV, et al: Machine perfusion as a tool to select kidneys recovered from uncontrolled donors after cardiac death. *Transplant Proc* 40:1023, 2008
3. Snoeijis MGJ, Buurman WA, Christiaans MHL, et al: Histological assessment of preimplantation biopsies may improve selection of kidneys from old donors after cardiac death. *Am J Transplant* 8:1844, 2008
4. Papas KK, Hering BJ, Guenther L, et al: Pancreas oxygenation is limited during preservation with the two-layer method. *Transplant Proc* 37:3501, 2005
5. Stowe DF, Camara AK, Heisner JS, et al: Low-flow perfusion of guinea pig isolated hearts with 26°C air-saturated Lifer solution for 20 hours preserves function and metabolism. *J Heart Lung Transplant* 27:1008, 2008
6. Dutkowski P, Furrer K, Tian Y, et al: Novel short-term hypothermic oxygenated perfusion (HOPE) system prevents injury in rat liver graft from non-heart beating donor. *Ann Surg* 244:968, 2006
7. Levy MN: Oxygen consumption and blood flow in the hypothermic, perfused kidney. *Am J Physiol* 197:1111, 1959
8. Stubenitsky BM, Booster MM, Brasile L, et al: Ex vivo viability testing of kidneys after postmortem warm ischemia. *ASAIO J* 46:62, 2000
9. Crane NJ, Pinto PA, Hale D, et al: Non-invasive monitoring of tissue oxygenation during laparoscopic donor nephrectomy. *BMC Surg* 8:8, 2008

10. Papas KK, Pisania A, Wu H, et al: A stirred microchamber for oxygen consumption rate measurements with pancreatic islets. *Biotechnol Bioeng* 98:1071, 2007
11. Papas KK, Colton CK, Nelson RA, et al: Human islet oxygen consumption rate and DNA measurements predict diabetes reversal in nude mice. *Am J Transplant* 7:707, 2007
12. Papas KK, Suszynski TM, Colton CK: Islet assessment for transplantation. *Curr Opin Org Transplant* 14:674, 2009
13. Taylor MJ, Baicu SC: Current state of hypothermic machine perfusion preservation of organs: The clinical perspective. *Cryobiology*. Published online Oct 24, 2009
14. Kim J, Seok YM, Jung KJ, et al: Reactive oxygen species/oxidative stress contributes to progression of kidney fibrosis following transient ischemic injury in mice. *Am J Physiol Renal Physiol* 297:F461, 2009
15. Treckmann J, Nagelschmidt M, Minor T, et al: Function and quality of kidneys after cold storage, machine perfusion, or retrograde oxygen persufflation: results from a porcine autotransplantation model. *Cryobiology* 59:19, 2009

## Chapter 10: Conclusions and Future Directions

Over the course of this work, a novel method for pancreas preservation, anterograde-oxygen persufflation (PSF) has been developed. Portable equipment (both by car and airplane) has been developed to provide oxygen, on demand, from procurement until arrival at the islet isolation facility. A non-invasive method to monitor ATP levels during preservation has been developed and utilized to compare PSF with other presently utilized methods of pancreas preservation [1, 2]. A pig model was developed and optimized to test PSF. The use of MRI and NMR has demonstrated that gaseous oxygen can routinely and homogeneously be delivered throughout the pancreas in both the pig and the human and that by delivering oxygen, ATP levels can be maintained for at least 24 hours of preservation[2]. It has also been shown that PSF improves preservation at extended time points as assessed by histology and perhaps more importantly by islet isolation outcomes[3]. This demonstrates not only the potential of PSF, but also the importance of maintaining ATP throughout organ preservation and the potential for  $^{31}\text{P}$ -NMR spectroscopy to aid in the development of methods or agents to improve organ preservation.

In the future, further work should be done to demonstrate the potential for PSF to improve human islet transplantation outcomes and enable the extension of preservation time. If this could be accomplished and applied clinically, the need to keep an isolation team on 24-hour overnight call could be eliminated; saving money and perhaps more importantly reducing staff turnover due to burnout.

PSF should be further investigated and optimized in other organs. Initial studies are already being pursued for the application of PSF in the heart, lungs, liver, kidneys as well as composite tissues (such as whole limbs) all presently in varying stages of development utilizing the methods presented in this dissertation. Once efficacious surgical protocols are developed to consistently deliver gas through these organs as confirmed by MRI, <sup>31</sup>P-NMR spectroscopy should be implemented to better understand the impact of PSF on these tissues as well as the ‘long-term’ tolerance of each of these organs to PSF. This would help establish the limits of PSF preservation for each organ and provide defined windows to investigate its efficacy in each organ model.

In addition to PSF, other methods of providing continuous oxygenation to tissues during preservation should be further investigated. The application of oxygenated liquid perfusion; perhaps with oxygen carriers should be pursued. The addition of various ‘cytoprotective’ agents (JNK-inhibitors, antioxidants, etc) should be further investigated both independently and in conjunction with either PSF or liquid perfusion. It is possible that by combining several agents we may be able to synergistically protect tissues. It is important that each organ is investigated independently as what works best for one tissue may not work best for another since they are fundamentally different systems.

The method for whole-organ oxygen consumption rate (WO-OCR) presented [4] should be further investigated to assess its potential predictive value to kidney transplantation outcomes. This could enable the usage of more extended criteria donors enabling a greater throughput and reducing waiting lists as well as potentially preventing the

transplantation of unsuitable grafts which may presently be transplanted. Once this is established, this technique could also become another 'cost-effective' tool to develop other methods of preservation and evaluate cytoprotective agents during preservation. The application of this technique to other, 'more technically complicated' organs should also be further developed so that this tool can become more robust in aiding with the development of novel preservation strategies.

If the methods presented here are implemented in a wide variety of organ systems; we will be able to better optimize preservation strategies for each organ, enabling more patients to receive transplants with a lower risk of failure.

## References:

1. Scott WE, 3rd, Matsumoto S, Tanaka T, Avgoustiniatos ES, Graham ML, Williams PC et al. Real-time noninvasive assessment of pancreatic ATP levels during cold preservation. *Transplant Proc* 2008;40(2):403-406.
2. Scott WE, 3rd, Weegman BP, Ferrer-Fabrega J, Stein SA, Anazawa T, Kirchner VA et al. Pancreas Oxygen Persufflation Increases ATP Levels as Shown by Nuclear Magnetic Resonance. *Transplant Proc* 2010;42(6):2011-2015.
3. Scott III WE, O'Brien TD, Ferrer-Fabrega J, Avgoustiniatos ES, Weegman BP, Anazawa T et al. Persufflation improves pancreas preservation when compared with the two-layer method (TLM). *Transplant Proc* 2010;42(6):2016-2019.
4. Weegman BP, Kirchner VA, Scott III WE, Avgoustiniatos ES, Suszynski TM, Ferrer-Fabrega J et al. Continuous real-time viability assessment of kidneys based on oxygen consumption. *Transplant Proc* 2010;42(6):2020-2023.

## Bibliography:

- American Diabetes Association: The Cost of Diabetes, <http://www.diabetes.org/advocate/resources/cost-of-diabetes.html>.
- Center for Disease Control: National Diabetes Fact Sheet, 2011, [http://www.cdc.gov/diabetes/pubs/pdf/ndfs\\_2011.pdf](http://www.cdc.gov/diabetes/pubs/pdf/ndfs_2011.pdf).
- World Health Organization: Diabetes Fact sheet N°312, <http://www.who.int/mediacentre/factsheets/fs312/en/index.html>.
- World Health Organization: Diabetes Programme, <http://www.who.int/diabetes/en/>
- Agrawal, A., K. Gurusamy, et al. (2008). "A meta-analysis of the impact of the two-layer method of preservation on human pancreatic islet transplantation." Cell Transplant **17**(12): 1315-1322.
- Agrawal, A., P. W. So, et al. (2010). "Limited penetration of perfluorocarbon in porcine pancreas preserved by two-layer method with (19)fluorine magnetic resonance spectroscopy and headspace gas chromatography." Cell Transplant **19**(8): 1021-1029.
- Anazawa, T., A. N. Balamurugan, et al. (2010). "Improved method of porcine pancreas procurement with arterial flush and ductal injection enhances islet isolation outcome." Transplant Proc **42**(6): 2032-2035.
- Anderson, C. D., A. Belous, et al. (2004). "Mitochondrial calcium uptake regulates cold preservation-induced Bax translocation and early reperfusion apoptosis." Am J Transplant **4**(3): 352-362.
- Arias-Mendoza, F. and T. R. Brown (2003). "In vivo measurement of phosphorous markers of disease." Dis Markers **19**(2-3): 49-68.
- Arita S, A. T., Kenmochi T, Enomoto K, Isono K (1991). "An Initial Wash-Out Solution for " In Situ Machine Wash Out"." Transplantation Proceedings **23**(5): 2589-2591.
- Avgoustiniatos, E., E. Scott III, et al. (In Press). "Supplements in Human Islet Culture: Human Serum Albumin is Inferior to Fetal Bovine Serum. ." Cell Transplantation.
- Avgoustiniatos, E. S., B. J. Hering, et al. (2006). "The rat pancreas is not an appropriate model for testing the preservation of the human pancreas with the two-layer method." Transplantation **81**(10): 1471-1472; author reply 1472.
- Badet, L., P. Y. Benhamou, et al. (2007). "Expectations and strategies regarding islet transplantation: metabolic data from the GRAGIL 2 trial." Transplantation **84**(1): 89-96.
- Ballinger, W. F. and P. E. Lacey (1972). "Transplantation of intact pancreatic islets in rats." Surgery **72**(2): 175-186.
- Barnard, C. N. (1967). "The operation. A human cardiac transplant: an interim report of a successful operation performed at Groote Schuur Hospital, Cape Town." S Afr Med J **41**(48): 1271-1274.
- Barnard, M. L., K. K. Changani, et al. (1997). "The role of magnetic resonance spectroscopy in the assessment of kidney viability." Scand J Urol Nephrol **31**(5): 487-492.



- Bellin, M. D., R. Kandaswamy, et al. (2008). "Prolonged insulin independence after islet allotransplants in recipients with type 1 diabetes." Am J Transplant **8**(11): 2463-2470.
- Bihler, I., M. Hollands, et al. (1970). "Stimulation of sugar transport by a factor released from gas-perfused hearts." Can J Physiol Pharmacol **48**(6): 327-332.
- Brandhorst, D., M. Iken, et al. (2005). "Long-term preservation of the pig pancreas by a one-layer method for successful islet isolation." Transplant Proc **37**(1): 229-230.
- Brandhorst, D., M. Iken, et al. (2005). "Successful pancreas preservation by a perfluorocarbon-based one-layer method for subsequent pig islet isolation." Transplantation **79**(4): 433-437.
- Brandhorst, H., S. Asif, et al. (2010). "A new oxygen carrier for improved long-term storage of human pancreata before islet isolation." Transplantation **89**(2): 155-160.
- Brandhorst, H., M. Iken, et al. (In Press). "Quality of isolated pig islets is improved using perfluorohexyloctane for pancreas storage in a split lobe model." Cell Transplantation.
- Brockbank, K. G. and M. J. Taylor (2007). Tissue Preservation. Advances in Biopreservation. J. G. Baust and J. M. Baust. Boca Raton, CRC Press: 157-196.
- Brown, J., J. A. Kemp, et al. (1980). "Cryopreservation of human fetal pancreas." Diabetes **29 Suppl 1**: 70-73.
- Bruick, R. K. (2000). "Expression of the gene encoding the proapoptotic Nip3 protein is induced by hypoxia." Proc Natl Acad Sci U S A **97**(16): 9082-9087.
- Brygner, H. (1975). "Twenty-Four-Hour Preservation of the Duct-Ligated Canine Pancreatic Allograft." European Surgical Research Journal **1975**(7): 341-354.
- Bunzl, A., A. S. Burgen, et al. (1954). "Methods for studying the reflex activity of the frog's spinal cord." Br J Pharmacol Chemother **9**(2): 229-235.
- Burns, B. D., J. G. Robson, et al. (1958). "The survival of mammalian tissues perfused with intravascular gas mixtures of oxygen and carbon dioxide." Can J Biochem Physiol **36**(5): 499-504.
- Caballero-Corbalan, J., T. Eich, et al. (2007). "No beneficial effect of two-layer storage compared with UW-storage on human islet isolation and transplantation." Transplantation **84**(7): 864-869.
- Caballero-Corbalan J, E. T., Foss A, Felldin M, Kallen R, Lundgren T, Salmela K, Tibell A, Tufveson G, Korsgren O (2006). "No beneficial effect of the two layer method (PFCUW) compared with transportation in UW alone on the outcome of human islet isolation and transplantation: a report of 214 human pancreases." American Journal of Transplantation **6**(Suppl 2): 340.
- Calne, R. Y., R. A. Sells, et al. (1972). "Multiple organ grafts in the pig. Techniques and results of pancreatic, hepatic, cardiac, and renal allografts." Br J Surg **59**(12): 969-977.
- Camishion, R. C., A. L. Davies, et al. (1966). "Retrograde perfusion of the coronary arteries with gaseous oxygen cardiopulmonary bypass." Surgery **59**(1): 145-154.
- Cardona, K., G. S. Korbitt, et al. (2006). "Long-term survival of neonatal porcine islets in nonhuman primates by targeting costimulation pathways." Nat Med **12**(3): 304-306.

- Carlsson, P. O., A. Kiuru, et al. (2002). "Microdialysis measurements demonstrate a shift to nonoxidative glucose metabolism in rat pancreatic islets transplanted beneath the renal capsule." Surgery **132**(3): 487-494.
- Crane, N. J., P. A. Pinto, et al. (2008). "Non-invasive monitoring of tissue oxygenation during laparoscopic donor nephrectomy." BMC Surg **8**: 8.
- Criddle, D. N., J. Murphy, et al. (2006). "Fatty acid ethyl esters cause pancreatic calcium toxicity via inositol trisphosphate receptors and loss of ATP synthesis." Gastroenterology **130**(3): 781-793.
- Davidson, B. R., M. L. Barnard, et al. (1997). "Liver transplantation: current and potential applications of magnetic resonance spectroscopy." Liver Transpl Surg **3**(5): 481-493.
- Denecke, H., W. Isselhard, et al. (1971). Recovery of the kidney from aerobic and anaerobic ischemia in deep hypothermia. European Society for Experimental Surgery, 6th Congress, Eur Sur Res.
- Dijkhuis CM, W. D., De Gruyl J, Oldenhof J, Drop A (1972). 24-Hour Isolated Canine Pancreas Preservation on the Belzer Machine. European Society for Experimental Surgery 7th Congress.
- Dionne, K. E., C. K. Colton, et al. (1993). "Effect of hypoxia on insulin secretion by isolated rat and canine islets of Langerhans." Diabetes **42**(1): 12-21.
- Dobbins, R. L. and C. R. Malloy (2003). "Measuring in-vivo metabolism using nuclear magnetic resonance." Curr Opin Clin Nutr Metab Care **6**(5): 501-509.
- Doepfner, T. R., T. Grune, et al. (2003). "Cold-induced apoptosis of rat liver endothelial cells: involvement of the proteasome." Transplantation **75**(12): 1946-1953.
- Dufrane, D., W. D'Hoore, et al. (2006). "Parameters favouring successful adult pig islet isolations for xenotransplantation in pig-to-primate models." Xenotransplantation **13**(3): 204-214.
- Dutkowski, P., K. Furrer, et al. (2006). "Novel short-term hypothermic oxygenated perfusion (HOPE) system prevents injury in rat liver graft from non-heart beating donor." Ann Surg **244**(6): 968-976; discussion 976-967.
- Ferrer, J., W. E. Scott, 3rd, et al. (2008). "Pig pancreas anatomy: implications for pancreas procurement, preservation, and islet isolation." Transplantation **86**(11): 1503-1510.
- Fiorina, P. and A. Secchi (2007). "Pancreatic islet cell transplant for treatment of diabetes." Endocrinol Metab Clin North Am **36**(4): 999-1013; ix.
- Fischer, J., C. Funcke, et al. (2001). "Coronary endothelial function in heart grafts of non-heart-beating donors (NHBD) after 3 h hypothermic COP-preservation and orthotopic transplantation in pigs." Eur Surg Res **33**: 130-131.
- Fischer, J. H. (1980). "Hypothermic liver preservation using different flush solutions and retrograde oxygen persufflation technique." Eur Surg Res **12**(Suppl 1): 19-20.
- Fischer, J. H. (2011). Methods of Cardiac Oxygen Persufflation. Organ Preservation and Reengineering. K. Uygun and C. Y. Lee. Boston, Artech House Publisher: 105-126.
- Fischer, J. H., M. Fuhs, et al. (1980). "[Deuterium oxide (D<sub>2</sub>O)--a protective factor for cellular stabilization in hypothermic preservation of the liver? (author's transl)]." Chir Forum Exp Klin Forsch: 129-133.

- Fischer, J. H., C. Funcke, et al. (2004). "Maintenance of physiological coronary endothelial function after 3.3 h of hypothermic oxygen persufflation preservation and orthotopic transplantation of non-heart-beating donor hearts." Eur J Cardiothorac Surg **25**(1): 98-104.
- Fischer, J. H., F. Kuhn-Regnier, et al. (1998). "Excellent recovery after prolonged heart storage by preservation with coronary oxygen persufflation: orthotopic pig heart transplantations after 14-hr storage." Transplantation **66**(11): 1450-1459.
- Flatmark, A., O. Slaattelid, et al. (1975). "Gaseous persufflation during machine perfusion of human kidneys before transplantation." Eur Surg Res **7**(2): 83-90.
- Florack, G., D. E. Sutherland, et al. (1983). "Preservation of canine segmental pancreatic autografts: cold storage versus pulsatile machine perfusion." J Surg Res **34**(5): 493-504.
- Frank, A., S. Deng, et al. (2004). "Transplantation for type I diabetes: comparison of vascularized whole-organ pancreas with isolated pancreatic islets." Ann Surg **240**(4): 631-640; discussion 640-633.
- Frank, A. M., C. F. Barker, et al. (2005). "Comparison of whole organ pancreas and isolated islet transplantation for type 1 diabetes." Adv Surg **39**: 137-163.
- Froud, T., C. Ricordi, et al. (2005). "Islet transplantation in type 1 diabetes mellitus using cultured islets and steroid-free immunosuppression: Miami experience." Am J Transplant **5**(8): 2037-2046.
- Fujino, Y., Y. Kuroda, et al. (1991). "Preservation of canine pancreas for 96 hours by a modified two-layer (UW solution/perfluorochemical) cold storage method." Transplantation **51**(5): 1133-1135.
- Gabel, H., H. Brynager, et al. (1983). "Pancreas transplantation in streptozotocin-diabetic juvenile pigs. Evaluation of function among duct-ligated, duct-occluded, and nonligated allografts." Transplantation **36**(6): 609-614.
- Gabel, L. P., I. Bihler, et al. (1966). "Contractility, metabolism and pharmacological reactions of isolated gas-perfused cat hearts." Circ Res **19**(5): 891-902.
- Ganger, K. H., D. Mettler, et al. (1987). "Experimental pancreaticosplenic composite transplantation in the pig. Operative technique and assessment of graft function." Eur Surg Res **19**(5): 323-328.
- Gillies, R. J. (1994). NMR in Physiology and Biomedicine, Academic Press Inc.
- Gillies, R. J. and D. L. Morse (2005). "In vivo magnetic resonance spectroscopy in cancer." Annu Rev Biomed Eng **7**: 287-326.
- Gott, V. L., J. L. Gonzalez, et al. (1957). "Retrograde perfusion of the coronary sinus for direct vision aortic surgery." Surg Gynecol Obstet **104**(3): 319-328.
- Guarrera, J. V., S. D. Henry, et al. (2010). "Hypothermic machine preservation in human liver transplantation: the first clinical series." Am J Transplant **10**(2): 372-381.
- Günther, H. (1980). NMR Spectroscopy, John Wiley & Sons Ltd.
- Harrison, J. H., J. P. Merrill, et al. (1956). "Renal homotransplantation in identical twins." Surg Forum **6**: 432-436.
- HE König, H.-G. L. (2004). Veterinary anatomy of domestic mammals, textbook and colour atlas. Stuttgart, Schattauer.
- Hering, B. J., R. Kandaswamy, et al. (2005). "Single-donor, marginal-dose islet transplantation in patients with type 1 diabetes." JAMA **293**(7): 830-835.

- Hering, B. J., I. Matsumoto, et al. (2002). "Impact of two-layer pancreas preservation on islet isolation and transplantation." Transplantation **74**(12): 1813-1816.
- Hering, B. J., M. Wijkstrom, et al. (2006). "Prolonged diabetes reversal after intraportal xenotransplantation of wild-type porcine islets in immunosuppressed nonhuman primates." Nat Med **12**(3): 301-303.
- Hiraoka, K., Y. Kuroda, et al. (2002). "Outcomes in clinical pancreas transplantation with the two-layer cold storage method versus simple storage in University of Wisconsin solution." Transplant Proc **34**(7): 2688-2689.
- Hiraoka, K., A. Trexler, et al. (2001). "Optimal temperature in pancreas preservation by the two-layer cold storage method before islet isolation." Transplant Proc **33**(1-2): 891-892.
- Hogan, A., A. Pileggi, et al. (2008). "Transplantation: current developments and future directions; the future of clinical islet transplantation as a cure for diabetes." Front Biosci **13**: 1192-1205.
- Horn, M. (2006). "Cardiac magnetic resonance spectroscopy: a window for studying physiology." Methods Mol Med **124**: 225-248.
- Hornak, J. (1996). The basics of MRI.
- Hosgood, S. A. and M. L. Nicholson (2010). "The Role of Perfluorocarbon in Organ Preservation." Transplantation.
- Hullett, D. A., K. P. Bethke, et al. (1989). "Successful long-term cryopreservation and transplantation of human fetal pancreas." Diabetes **38**(4): 448-453.
- Ishii, S., Y. Sato, et al. (2004). "A novel method for determination of ATP, ADP, and AMP contents of a single pancreatic islet before transplantation." Transplant Proc **36**(4): 1191-1193.
- Isselhard, W. (1978). "Efficiency of retrograde oxygen persufflation in prolonged kidney preservation." Eur Surg Res **10**(Suppl 1): 19-20.
- Isselhard, W., M. Berger, et al. (1972). "Metabolism of canine kidneys in anaerobic ischemia and in aerobic ischemia by persufflation with gaseous oxygen." Pflugers Arch **337**(2): 87-106.
- Isselhard, W., H. Denecke, et al. (1973). "Function and metabolism of canine kidneys after aerobic ischemia by orthograde persufflation with gaseous oxygen." Res Exp Med (Berl) **159**(4): 288-297.
- Isselhard, W., H. Denecke, et al. (1972). "[Renal function after hypothermic kidney ischemia with orthograde and retrograde O<sub>2</sub>-persufflation in situ]." Res Exp Med (Berl) **157**(3): 231-234.
- Isselhard, W. and T. Minor (1999). "[Gaseous oxygen for protection and conditioning of organs during ischemia]." Zentralbl Chir **124**(4): 252-259.
- Isselhard, W., J. Witte, et al. (1972). "[Kidney function following hypothermic aerobic ischemia in situ]." Pflugers Arch **332**: Suppl 332:R326.
- Isselhard, W., J. Witte, et al. (1974). "Function and metabolism of canine kidneys after aerobic ischemia by retrograde persufflation with gaseous oxygen." Res Exp Med (Berl) **164**(1): 35-44.
- Iwanaga, Y., D. E. Sutherland, et al. (2008). "Pancreas preservation for pancreas and islet transplantation." Curr Opin Organ Transplant **13**(4): 445-451.
- Jensen, S. L., C. Kuhl, et al. (1976). "Isolation and perfusion of the porcine pancreas." Scand J Gastroenterol Suppl **37**: 57-61.

- Jeschkeit, S. (1997). "Significantly improved functional recovery after preservation with coronary oxygen persufflation (PCOP) during hypothermic heart storage." Eur Surg Res **29**(Suppl 1).
- K Ulrichs, M. B., A Heiser, V Eckstein, H Wacker, A Theide, W Muller-Ruchhoitz (1995). "Histomorphological characteristics of the porcine pancreas as a basis for the isolation of islets of Langerhans." Xenotransplantation **2**(3): 176-187.
- Karcz, M., H. T. Cook, et al. (2010). "An ex-vivo model for hypothermic pulsatile perfusion of porcine pancreata: hemodynamic and morphologic characteristics." Exp Clin Transplant **8**(1): 55-60.
- Kawamura, T., Y. Kuroda, et al. (1992). "Long-term preservation of canine pancreas by a new simple cold storage method using perfluorochemical--the two-layer cold storage method (Euro-Collins' solution/perfluorochemical)." Kobe J Med Sci **38**(2): 135-145.
- Kawamura, T., Y. Kuroda, et al. (1989). "A new simple two layer (Euro-Collins' solution/perfluorochemical) cold storage method for pancreas preservation." Transplant Proc **21**(1 Pt 2): 1376-1377.
- Kemp, J. A., P. Mazur, et al. (1977). "Reversal of experimental diabetes by fetal rat pancreas. I. Survival and function of fetal rat pancreas frozen to -196°C." Transplantation Proceedings **9**: 325-328.
- Kemp, J. A., Y. Mullen, et al. (1978). "Reversal of diabetes in rats using fetal pancreas stored at -196°C." Transplantation Proceedings **26**: 260-264.
- Kenmochi, T., T. Asano, et al. (1992). "Prediction of viability of ischemically damaged canine pancreatic grafts by tissue flow rate with machine perfusion." Transplantation **53**(4): 745-750.
- Keymeulen, B., P. Gillard, et al. (2006). "Correlation between beta cell mass and glycemic control in type 1 diabetic recipients of islet cell graft." Proc Natl Acad Sci U S A **103**(46): 17444-17449.
- Khan, S. A., I. J. Cox, et al. (2005). "In vivo and in vitro nuclear magnetic resonance spectroscopy as a tool for investigating hepatobiliary disease: a review of H and P MRS applications." Liver Int **25**(2): 273-281.
- Kim, J., Y. M. Seok, et al. (2009). "Reactive oxygen species/oxidative stress contributes to progression of kidney fibrosis following transient ischemic injury in mice." Am J Physiol Renal Physiol **297**(2): F461-470.
- Kim, J. H., H. I. Kim, et al. (2007). "Influence of strain and age differences on the yields of porcine islet isolation: extremely high islet yields from SPF CMS miniature pigs." Xenotransplantation **14**(1): 60-66.
- Kim, J. S. and J. H. Southard (1998). "Alteration in cellular calcium and mitochondrial functions in the rat liver during cold preservation." Transplantation **65**(3): 369-375.
- Kin, T., M. Mirbolooki, et al. (2006). "Islet isolation and transplantation outcomes of pancreas preserved with University of Wisconsin solution versus two-layer method using preoxygenated perfluorocarbon." Transplantation **82**(10): 1286-1290.
- Kin, T., T. B. Murdoch, et al. (2006). "Estimation of pancreas weight from donor variables." Cell Transplant **15**(2): 181-185.

- Kirchhof, N., B. J. Hering, et al. (1994). "Evidence for breed-dependent differences in porcine islets of Langerhans." Transplant Proc **26**(2): 616-617.
- Knoll, G. (2008). "Trends in kidney transplantation over the past decade." Drugs **68 Suppl 1**: 3-10.
- Kotting, M. and T. Minor (2000). "Biochemical effects and cyclic-AMP second messenger signal upon venous oxygen persufflation of ischemically preserved livers." Transplant Proc **32**(1): 11-13.
- Krickhahn, M., C. Buhler, et al. (2002). "The morphology of islets within the porcine donor pancreas determines the isolation result: successful isolation of pancreatic islets can now be achieved from young market pigs." Cell Transplant **11**(8): 827-838.
- Kruger, B., E. Albrecht, et al. (2000). "The role of intracellular calcium signaling in premature protease activation and the onset of pancreatitis." Am J Pathol **157**(1): 43-50.
- Kuhn-Regnier, F., W. Bloch, et al. (2004). "Coronary oxygen persufflation for heart preservation in pigs: analyses of endothelium and myocytes." Transplantation **77**(1): 28-35.
- Kuhn-Regnier, F., J. H. Fischer, et al. (1998). "Coronary oxygen persufflation for long-term myocardial protection." Thorac Cardiovasc Surg **46 Suppl 2**: 308-312.
- Kuhn-Regnier, F., J. H. Fischer, et al. (2000). "Coronary oxygen persufflation combined with HTK cardioplegia prolongs the preservation time in heart transplantation." Eur J Cardiothorac Surg **17**(1): 71-76.
- Kumagai, N., J. J. O'Neil, et al. (2002). "Vascularized islet-cell transplantation in miniature swine. I. Preparation of vascularized islet kidneys." Transplantation **74**(9): 1223-1230.
- Kuroda, Y., T. Kawamura, et al. (1988). "A new, simple method for cold storage of the pancreas using perfluorochemical." Transplantation **46**(3): 457-460.
- Laine, G. A. and S. J. Allen (1991). "Left ventricular myocardial edema. Lymph flow, interstitial fibrosis, and cardiac function." Circ Res **68**(6): 1713-1721.
- Lakey, J. R., P. W. Burridge, et al. (2003). "Technical aspects of islet preparation and transplantation." Transpl Int **16**(9): 613-632.
- Lakey, J. R., T. Tsujimura, et al. (2002). "Preservation of the human pancreas before islet isolation using a two-layer (UW solution-perfluorochemical) cold storage method." Transplantation **74**(12): 1809-1811.
- Lauschke, H., M. Kotting, et al. (2003). "Use of taurine as antioxidant in resuscitating livers from non-heart-beating donors by gaseous oxygen persufflation." J Invest Surg **16**(1): 7-11.
- Leeser, D. B., A. W. Bingaman, et al. (2004). "Pulsatile pump perfusion of pancreata before human islet cell isolation." Transplant Proc **36**(4): 1050-1051.
- Lepore, D. A., T. A. Shinkel, et al. (2004). "Enhanced expression of glutathione peroxidase protects islet beta cells from hypoxia-reoxygenation." Xenotransplantation **11**(1): 53-59.
- Levy, M. N. (1959). "Oxygen consumption and blood flow in the hypothermic, perfused kidney." Am J Physiol **197**: 1111-1114.
- Lochner, W., G. Arnold, et al. (1968). "Metabolism of the artificially arrested heart and of the gas-perfused heart." Am J Cardiol **22**(3): 299-311.

- Luer, B., M. Koetting, et al. (2010). "Role of oxygen during hypothermic machine perfusion preservation of the liver." Transpl Int **23**(9): 944-950.
- Magnus, R. (1902). "Die Thätigkeit des überlebenden Säugethierherzens bei Durchströmung mit Gasen." Arch Exp Path Pharmacol **47**: 200-208.
- Marada, T., K. Zacharovova, et al. (2010). "Perfluorocarbon Improves Post-Transplant Survival and Early Kidney Function following Prolonged Cold Ischemia." Eur Surg Res **44**(3-4): 170-178.
- Massimo, C., L. Boffi, et al. (1958). "Sinusal standstill with ventricular automatism during retrograde perfusion of the coronary sinus under hypothermia for direct surgical approach to the aortic valves: an experimental study." J Thorac Surg **36**(2): 227-229.
- Matsumoto, S. and Y. Kuroda (2002). "Perfluorocarbon for organ preservation before transplantation." Transplantation **74**(12): 1804-1809.
- Matsumoto, S., G. Zhang, et al. (2004). "Analysis of donor factors affecting human islet isolation with current isolation protocol." Transplant Proc **36**(4): 1034-1036.
- Matsumoto, S., G. Zhang, et al. (2004). "The effect of two-layer (University of Wisconsin solution/perfluorochemical) preservation method on clinical grade pancreata prior to islet isolation and transplantation." Transplant Proc **36**(4): 1037-1039.
- Matsuoka, L., T. Shah, et al. (2006). "Pulsatile perfusion reduces the incidence of delayed graft function in expanded criteria donor kidney transplantation." Am J Transplant **6**(6): 1473-1478.
- Mellert, J., B. J. Hering, et al. (1999). "Critical islet mass for successful porcine islet autotransplantation." J Mol Med (Berl) **77**(1): 126-129.
- Merrill, J. P., J. E. Murray, et al. (1956). "Successful homotransplantation of the human kidney between identical twins." J Am Med Assoc **160**(4): 277-282.
- Minor, T., S. Akbar, et al. (2000). "Cold preservation of fatty liver grafts: prevention of functional and ultrastructural impairments by venous oxygen persufflation." J Hepatol **32**(1): 105-111.
- Minor, T. and W. Isselhard (1994). "Venous oxygen insufflation to prevent reoxygenation injury after ischemia of a solid organ." Transplantation **58**(1): 121-123.
- Minor, T. and W. Isselhard (1996). "Synthesis of high energy phosphates during cold ischemic rat liver preservation with gaseous oxygen insufflation." Transplantation **61**(1): 20-22.
- Minor, T., W. Isselhard, et al. (1996). "Reduction in nonparenchymal cell injury and vascular endothelial dysfunction after cold preservation of the liver by gaseous oxygen." Transpl Int **9 Suppl 1**: S425-428.
- Minor, T., W. Isselhard, et al. (1993). "The effects of allopurinol and SOD on lipid peroxidation and energy metabolism in the liver after ischemia in an aerobic/anaerobic persufflation." Surg Today **23**(8): 728-732.
- Minor, T., H. Klauke, et al. (1996). "Resuscitation of cadaveric livers from non-heart-beating donors after warm ischemic insult: a novel technique tested in the rat." Experientia **52**(7): 661-664.

- Minor, T., H. Klauke, et al. (1997). "Improved preservation of the small bowel by luminal gas oxygenation: energetic status during ischemia and functional integrity upon reperfusion." Transplant Proc **29**(7): 2994-2996.
- Minor, T., H. Klauke, et al. (1997). "Reduction of proteolysis by venous-systemic oxygen persufflation during rat liver preservation and improved functional outcome after transplantation." Transplantation **63**(3): 365-368.
- Minor, T., H. Klauke, et al. (1997). "Biophysical aspects of liver aeration by vascular persufflation with gaseous oxygen." Transplantation **63**(12): 1843-1846.
- Minor, T., H. Klauke, et al. (1997). "Rat liver transplantation after long-term preservation by venous systemic oxygen persufflation." Transplant Proc **29**(1-2): 410-411.
- Minor, T., S. Saad, et al. (1997). "Short-term restoration by gaseous oxygen for long-term preservation of predamaged livers from non-heart-beating donors." Transplant Proc **29**(8): 3474-3475.
- Minor, T., S. Saad, et al. (1998). "Endischemic oxygen persufflation to improve viability of marginally preserved donor livers." Transpl Int **11 Suppl 1**: S400-403.
- Minor, T., S. Saad, et al. (1998). "Successful transplantation of porcine livers after warm ischemic insult in situ and cold preservation including postconditioning with gaseous oxygen." Transplantation **65**(9): 1262-1264.
- Minor, T., W. E. Scott, 3rd, et al. (2012). "Energetic recovery in porcine grafts by minimally invasive liver oxygenation." J Surg Res.
- Minor, T., J. Stegemann, et al. (2009). "Impaired autophagic clearance after cold preservation of fatty livers correlates with tissue necrosis upon reperfusion and is reversed by hypothermic reconditioning." Liver Transpl **15**(7): 798-805.
- Minor, T., B. Vollmar, et al. (1998). "[Differential effect of preservative solutions (UW vs HTK) on mitochondrial redox status and energy metabolism during liver ischemia with oxygen persufflation]." Langenbecks Arch Chir Suppl Kongressbd **115**(Suppl I): 377-381.
- Minor, T., B. Vollmar, et al. (1998). "Gaseous oxygenation of the ischemic rat liver. The influence of driving pressure and oxygen concentration on tissue aeration." Adv Exp Med Biol **454**: 91-94.
- Moers, C., J. M. Smits, et al. (2009). "Machine perfusion or cold storage in deceased-donor kidney transplantation." N Engl J Med **360**(1): 7-19.
- Morel, P., D. B. Kaufmann, et al. (1991). "Total pancreatectomy in the pig for islet transplantation. Technical alternatives." Transplantation **52**(1): 11-15.
- Moritz, W., F. Meier, et al. (2002). "Apoptosis in hypoxic human pancreatic islets correlates with HIF-1alpha expression." FASEB J **16**(7): 745-747.
- Morris, G. E., S. R. Williams, et al. (1989). "31P Nuclear Magnetic Resonance of Rat Pancreatic Grafts." Transplantation **47**(5): 779-784.
- Muldrew, K. (1997). Cryobiology - A Short Course. K. Muldrew.
- Najarian, J. S., D. E. Sutherland, et al. (1980). "Total or near total pancreatectomy and islet autotransplantation for treatment of chronic pancreatitis." Ann Surg **192**(4): 526-542.
- Nicholson, M. L., S. A. Hosgood, et al. (2004). "A comparison of renal preservation by cold storage and machine perfusion using a porcine autotransplant model." Transplantation **78**(3): 333-337.



- O'Neil, J. J., J. P. Stegemann, et al. (2001). "The isolation and function of porcine islets from market weight pigs." Cell Transplant **10**(3): 235-246.
- Ojo, A. O., R. A. Wolfe, et al. (1997). "Delayed graft function: risk factors and implications for renal allograft survival." Transplantation **63**(7): 968-974.
- Olschewski, P., F. Dombrowski, et al. (2004). "On the possible impact of the flushout solution in conditioning livers from non-heartbeating donors during preservation by gaseous oxygen." Transplant Proc **36**(7): 1931-1932.
- Paget, M., H. Murray, et al. (2007). "Human islet isolation: semi-automated and manual methods." Diab Vasc Dis Res **4**(1): 7-12.
- Papas, K. K., E. S. Avgoustiniatos, et al. (2005). "High-density culture of human islets on top of silicone rubber membranes." Transplant Proc **37**(8): 3412-3414.
- Papas, K. K., C. K. Colton, et al. (2007). "Human islet oxygen consumption rate and DNA measurements predict diabetes reversal in nude mice." Am J Transplant **7**(3): 707-713.
- Papas, K. K., B. J. Hering, et al. (2005). "Pancreas oxygenation is limited during preservation with the two-layer method." Transplant Proc **37**(8): 3501-3504.
- Papas, K. K., A. Pisania, et al. (2007). "A stirred microchamber for oxygen consumption rate measurements with pancreatic islets." Biotechnol Bioeng **98**(5): 1071-1082.
- Papas, K. K., T. M. Suszynski, et al. (2009). "Islet assessment for transplantation." Curr Opin Organ Transplant **14**(6): 674-682.
- Pegg, D. E., J. Foreman, et al. (1989). "The mechanism of action of retrograde oxygen persufflation in renal preservation." Transplantation **48**(2): 210-217.
- Perico, N., D. Cattaneo, et al. (2004). "Delayed graft function in kidney transplantation." Lancet **364**(9447): 1814-1827.
- Piratvisuth, T., J. M. Tredger, et al. (1995). "Contribution of true cold and rewarming ischemia times to factors determining outcome after orthotopic liver transplantation." Liver Transpl Surg **1**(5): 296-301.
- Pitkaranta, P., L. Kivisaari, et al. (1989). "Experimental chronic pancreatitis in the pig." Scand J Gastroenterol **24**: 987-992.
- Platz, K. P., A. R. Mueller, et al. (1997). "Influence of warm ischemia time on initial graft function in human liver transplantation." Transplant Proc **29**(8): 3458-3459.
- Ponte, G. M., A. Pileggi, et al. (2007). "Toward maximizing the success rates of human islet isolation: influence of donor and isolation factors." Cell Transplant **16**(6): 595-607.
- Prabhakaran, S. and B. J. Hering (2008). "What strain of pig should be used?" Xenotransplantation **15**(2): 83-86.
- Radosevich, D. M., R. Jevne, et al. (2010). "Abstracts of the 2010 American Transplant Congress. May 1-5, 2010. San Diego, California, USA; "Abstract #281: Comprehensive Health Assessment and 5-Year Follow-Up of Allogeneic Islet Transplant Recipients"." Am J Transplant **10 Suppl 4**: 123.
- Raraty, M., J. Ward, et al. (2000). "Calcium-dependent enzyme activation and vacuole formation in the apical granular region of pancreatic acinar cells." Proc Natl Acad Sci U S A **97**(24): 13126-13131.
- Reddy, M. S., A. Kibondo, et al. (2009). Improved preservation of non heart-beating-donor pancreases prior to islet isolation using portal venous oxygen persufflation. American Transplant Congress. Boston, MA.

- Reznik, O. N., S. F. Bagnenko, et al. (2008). "Machine perfusion as a tool to select kidneys recovered from uncontrolled donors after cardiac death." Transplant Proc **40**(4): 1023-1026.
- Ricordi, C., C. Fraker, et al. (2003). "Improved human islet isolation outcome from marginal donors following addition of oxygenated perfluorocarbon to the cold-storage solution." Transplantation **75**(9): 1524-1527.
- Ricordi, C., D. W. Gray, et al. (1990). "Islet isolation assessment in man and large animals." Acta Diabetol Lat **27**(3): 185-195.
- Ricordi, C., P. E. Lacy, et al. (1989). "Automated islet isolation from human pancreas." Diabetes **38 Suppl 1**: 140-142.
- Ricordi, C., C. Socci, et al. (1990). "Isolation of the elusive pig islet." Surgery **107**(6): 688-694.
- Rizzari, M. D., T. M. Suszynski, et al. (2010). "Surgical protocol involving the infusion of paramagnetic microparticles for preferential incorporation within porcine islets." Transplant Proc **42**(10): 4209-4212.
- Rolles, K., J. Foreman, et al. (1984). "Preservation of ischemically injured canine kidneys by retrograde oxygen persufflation." Transplantation **38**(2): 102-106.
- Rolles, K., J. Foreman, et al. (1989). "A pilot clinical study of retrograde oxygen persufflation in renal preservation." Transplantation **48**(2): 339-342.
- Rood, P. P., L. H. Buhler, et al. (2006). "Pig-to-nonhuman primate islet xenotransplantation: a review of current problems." Cell Transplant **15**(2): 89-104.
- Ross, H. and M. L. Escott (1979). "Gaseous oxygen perfusion of the renal vessels as an adjunct in kidney preservation." Transplantation **28**(5): 362-364.
- Ross, H. and M. L. Escott (1982). "Renal preservation with gaseous perfusion." Transplantation **33**(2): 206-208.
- Ryan, E. A., J. R. Lakey, et al. (2002). "Successful islet transplantation: continued insulin reserve provides long-term glycemic control." Diabetes **51**(7): 2148-2157.
- Ryan, E. A., J. R. Lakey, et al. (2001). "Clinical outcomes and insulin secretion after islet transplantation with the Edmonton protocol." Diabetes **50**(4): 710-719.
- Ryan, E. A., B. W. Paty, et al. (2005). "Five-year follow-up after clinical islet transplantation." Diabetes **54**(7): 2060-2069.
- Saad, S., T. Minor, et al. (2001). "Extension of ischemic tolerance of porcine livers by cold preservation including postconditioning with gaseous oxygen." Transplantation **71**(4): 498-502.
- Sabat, M., E. Godlewska, et al. (2003). "Assessment of some porcine strains as donors of islets of Langerhans." Transplant Proc **35**(6): 2343-2344.
- Sabiston, D. C., Jr., J. L. Talbert, et al. (1959). "Maintenance of the heart beat by perfusion of the coronary circulation with gaseous oxygen." Ann Surg **150**: 361-370.
- Sachweh, D., W. Isselhard, et al. (1972). "Short time kidney preservation by hypothermic oxygen persufflation." Bull Soc Int Chir **31**(4): 258-263.
- Sakuma, Y., C. Ricordi, et al. (2008). "Factors that affect human islet isolation." Transplant Proc **40**(2): 343-345.

- Schold, J. D., B. Kaplan, et al. (2005). "Are we frozen in time? Analysis of the utilization and efficacy of pulsatile perfusion in renal transplantation." Am J Transplant **5**(7): 1681-1688.
- Schroder, T., O. J. Ramo, et al. (1988). "Laser pancreatectomy. A comparison between dog and pig." Res Exp Med (Berl) **188**(3): 227-233.
- Scott III, W. E., E. S. Avgoustiniatos, et al. (2010). Pancreas oxygen persufflation increases ATP levels and improves islet viability compared with two-layer method (TLM). American Society of Transplant Surgeons (ASTS) - State of the Art Winter Symposium. Ft. Lauderdale, FL.
- Scott III, W. E., E. S. Avgoustiniatos, et al. "Persufflation improves pancreas preservation for islet isolation when compared with the two-layer method (TLM)." (in preparation).
- Scott III, W. E., T. D. O'Brien, et al. (2010). "Persufflation improves pancreas preservation when compared with the two-layer method (TLM)." Transplant Proc **42**(6): 2016-2019.
- Scott III, W. E., B. P. Weegman, et al. (2010). "Pancreas oxygen persufflation increases ATP levels as shown by nuclear magnetic resonance." Transplant Proc **42**(6): 2011-2015.
- Scott, W. E., 3rd, S. Matsumoto, et al. (2008). "Real-time noninvasive assessment of pancreatic ATP levels during cold preservation." Transplant Proc **40**(2): 403-406.
- Sekine, N., V. Cirulli, et al. (1994). "Low lactate dehydrogenase and high mitochondrial glycerol phosphate dehydrogenase in pancreatic beta-cells. Potential role in nutrient sensing." J Biol Chem **269**(7): 4895-4902.
- Shapiro, A. M., J. R. Lakey, et al. (2000). "Islet transplantation in seven patients with type 1 diabetes mellitus using a glucocorticoid-free immunosuppressive regimen." N Engl J Med **343**(4): 230-238.
- Shapiro, A. M., C. Ricordi, et al. (2003). "Edmonton's islet success has indeed been replicated elsewhere." Lancet **362**(9391): 1242.
- Shapiro, A. M., C. Ricordi, et al. (2006). "International trial of the Edmonton protocol for islet transplantation." N Engl J Med **355**(13): 1318-1330.
- Shokouh-Amiri, M. H., S. Rahimi-Saber, et al. (1989). "Segmental pancreatic autotransplantation in the pig." Transplantation **47**(1): 42-44.
- Shokouh-Amiri, M. H., S. Rahimi-Saber, et al. (1996). "Pancreas autotransplantation in pig with systemic or portal venous drainage. Effect on the endocrine pancreatic function after transplantation." Transplantation **61**(7): 1004-1009.
- Siech, M., C. H. Sotak, et al. (1995). "A method for in vivo assessment of reversible rat pancreatic ischemia using 31P NMR spectroscopy at 2.0 tesla." Magn Reson Imaging **13**(3): 463-469.
- Skjennald, A. (1982). "Anatomy of the liver and pancreas in the domestic swine, with special reference to vascular structures." Scand J Gastroenterol **17**(16).
- Snoeijs, M. G., W. A. Buurman, et al. (2008). "Histological assessment of preimplantation biopsies may improve selection of kidneys from old donors after cardiac death." Am J Transplant **8**(9): 1844-1851.
- So, P. W. and B. J. Fuller (2001). "A comparison of the metabolic effects of continuous hypothermic perfusion or oxygenated persufflation during hypothermic storage of rat liver." Cryobiology **43**(3): 238-247.

- Socci, C., C. Ricordi, et al. (1990). "Selection of donors significantly improves pig islet isolation yield." Horm Metab Res Suppl **25**: 32-34.
- Stegemann, J., A. Hirner, et al. (2009). "Gaseous oxygen persufflation or oxygenated machine perfusion with Custodiol-N for long-term preservation of ischemic rat livers?" Cryobiology **58**(1): 45-51.
- Stowe, D. F., A. K. Camara, et al. (2008). "Low-flow perfusion of guinea pig isolated hearts with 26 degrees C air-saturated Lifer solution for 20 hours preserves function and metabolism." J Heart Lung Transplant **27**(9): 1008-1015.
- Stowe, N. T., M. O. Magnusson, et al. (1986). "Combined use of normobaric oxygen perfusion and simple cold storage for extended kidney preservation." Transplant Proc **18**(3): 553-556.
- Stratta, R. J., P. S. Moore, et al. (2007). "Influence of pulsatile perfusion preservation on outcomes in kidney transplantation from expanded criteria donors." J Am Coll Surg **204**(5): 873-882; discussion 882-874.
- Stubenitsky, B. M., M. M. Booster, et al. (2000). "II: Ex vivo viability testing of kidneys after postmortem warm ischemia." ASAIO J **46**(1): 62-64.
- Sun, H. W., F. Shen, et al. (2006). "Influence of perfusion by gaseous oxygen persufflation on rat donor liver." Hepatobiliary Pancreat Dis Int **5**(2): 195-198.
- Suszynski, T. M., M. D. Rizzari, et al. (2012). "Persufflation (or gaseous oxygen perfusion) as a method of organ preservation." Cryobiology **64**(3): 125-143.
- Suszynski, T. M., G. M. Wildey, et al. (2008). "The ATP/DNA ratio is a better indicator of islet cell viability than the ADP/ATP ratio." Transplant Proc **40**(2): 346-350.
- Sutherland, D. E., C. E. Morrow, et al. (1983). "Cold storage preservation of islet and pancreas grafts as assessed by in vivo function after transplantation to diabetic hosts." Cryobiology **20**(2): 138-150.
- Swindle, M. Technical Bulletin. Comparative anatomy of the pig.
- Talbert, J. L., L. H. Riley, Jr., et al. (1960). "Retrograde perfusion of the coronary sinus with gaseous oxygen." Am Surg **26**: 189-192.
- Talbert, J. L., L. H. Riley, Jr., et al. (1961). "An evaluation of gaseous oxygen perfusion as a method for maintaining renal viability during periods of complete ischemia." Surg Gynecol Obstet **112**: 593-599.
- Tanaka, T., Y. Suzuki, et al. (2005). "Possibility of islet transplantation from a nonheartbeating donor pancreas resuscitated by the two-layer method." Transplantation **80**(6): 738-742.
- Taylor, M. J. (2007). Biology of cell survival in the cold: The basis for biopreservation of tissues and organs. Advances in biopreservation. J. G. Baust and J. M. Baust. Boca Raton, CRC Press: 15-62.
- Taylor, M. J. (2007). Hypothermia. Encyclopedia of stress. G. Fink. Oxford, Academic Press: 428-438.
- Taylor, M. J., S. Baicu, et al. (2010). "Islet isolation from juvenile porcine pancreas after 24-h hypothermic machine perfusion preservation." Cell Transplant **19**(5): 613-628.
- Taylor, M. J., S. Baicu, et al. (2008). "Twenty-four hour hypothermic machine perfusion preservation of porcine pancreas facilitates processing for islet isolation." Transplant Proc **40**(2): 480-482.

- Taylor, M. J. and S. C. Baicu (2009). "Current state of hypothermic machine perfusion preservation of organs: The clinical perspective." Cryobiology.
- Taylor, M. J. and S. C. Baicu (2010). "Current state of hypothermic machine perfusion preservation of organs: The clinical perspective." Cryobiology **60**(3 Suppl): S20-35.
- Taylor, M. J. and S. C. Baicu (2011). Hypothermic Perfusion of Pancreas: Emphasis on Preservation prior to Islet Isolation. Organ Preservation and Reengineering. K. Uykun and C. Y. Lee. Boston, Artech House Publisher: 85-104.
- Tolba, R. H., F. A. Schildberg, et al. (2006). "Reduced liver apoptosis after venous systemic oxygen persufflation in non-heart-beating donors." J Invest Surg **19**(4): 219-227.
- Toledo-Pereyra, L. H., K. D. Valgee, et al. (1980). "Hypothermic pulsatile perfusion: its use in the preservation of pancreases for 24 to 48 hours before islet cell transplantation." Arch Surg **115**(1): 95-98.
- Tolstyykh, G. P., J. F. Gelineau, et al. (2010). "Novel portable hypothermic pulsatile perfusion preservation technology: Improved viability and function of rodent and canine kidneys." Ann Transplant **15**(3): 35-43.
- Toso, C., D. Brandhorst, et al. (2000). "Isolation of adult porcine islets of Langerhans." Cell Transplant **9**(3): 297-305.
- Totsuka, E., U. Fung, et al. (2004). "Analysis of clinical variables of donors and recipients with respect to short-term graft outcome in human liver transplantation." Transplant Proc **36**(8): 2215-2218.
- Traverso, L. W. and S. MacFarlane (1987). "Pancreas autotransplantation--unsuitability of the swine as a model." Transplantation **44**(3): 450-451.
- Treckmann, J., T. Minor, et al. (2008). "Retrograde oxygen persufflation preservation of human livers: a pilot study." Liver Transpl **14**(3): 358-364.
- Treckmann, J., C. Moers, et al. (2011). "Machine perfusion versus cold storage for preservation of kidneys from expanded criteria donors after brain death." Transpl Int **24**(6): 548-554.
- Treckmann, J., M. Nagelschmidt, et al. (2009). "Function and quality of kidneys after cold storage, machine perfusion, or retrograde oxygen persufflation: results from a porcine autotransplantation model." Cryobiology **59**(1): 19-23.
- Treckmann, J. W., A. Paul, et al. (2006). "Primary organ function of warm ischaemically damaged porcine kidneys after retrograde oxygen persufflation." Nephrol Dial Transplant **21**(7): 1803-1808.
- Tsujimura, T., Y. Kuroda, et al. (2003). "Resuscitation of the ischemically damaged human pancreas by the two-layer method prior to islet isolation." Transplant Proc **35**(7): 2461-2462.
- Tsujimura, T., Y. Kuroda, et al. (2004). "Influence of pancreas preservation on human islet isolation outcomes: impact of the two-layer method." Transplantation **78**(1): 96-100.
- Tsujimura, T., Y. Kuroda, et al. (2002). "Human islet transplantation from pancreases with prolonged cold ischemia using additional preservation by the two-layer (UW solution/perfluorochemical) cold-storage method." Transplantation **74**(12): 1687-1691.

- Turegano-Fuentes, F., C. Garcia-Menendez, et al. (1990). "The feasibility of porcine pancreas autotransplantation--a case for controversy." Transplantation **49**(5): 1028-1029.
- Turgeon, N. A., J. G. Avila, et al. (2010). "Experience with a novel efalizumab-based immunosuppressive regimen to facilitate single donor islet cell transplantation." Am J Transplant **10**(9): 2082-2091.
- Vollmar, B., H. Klauke, et al. (1997). "Gaseous pathway in venous oxygen persufflation of the liver." J Hepatol **26**(6): 1429-1430.
- Wang, G. L. and G. L. Semenza (1993). "General involvement of hypoxia-inducible factor 1 in transcriptional response to hypoxia." Proc Natl Acad Sci U S A **90**(9): 4304-4308.
- Ward, J. B., O. H. Petersen, et al. (1995). "Is an elevated concentration of acinar cytosolic free ionised calcium the trigger for acute pancreatitis?" Lancet **346**(8981): 1016-1019.
- Weegman, B., M. Taylor, et al. (In Press). "Hypothermic Perfusion Preservation of Pancreas for Islet Grafts: Validation using a Split Lobe Porcine Model. ." Cell Transplantation.
- Weegman, B. P., V. A. Kirchner, et al. (2010). "Continuous real-time viability assessment of kidneys based on oxygen consumption." Transplant Proc **42**(6): 2020-2023.
- Weegman, B. P., M. J. Taylor, et al. (2012). "Hypothermic Perfusion Preservation of the Pancreas for Islet Grafts: Validation Using a Split Lobe Porcine Model." Cell Medicine, Part B of Cell Transplantation **2**: 105-110.
- Wight, J., J. Chilcott, et al. (2003). "The clinical and cost-effectiveness of pulsatile machine perfusion versus cold storage of kidneys for transplantation retrieved from heart-beating and non-heart-beating donors." Health Technol Assess **7**(25): 1-94.
- Yin, M., M. H. Booster, et al. (1996). "Retrograde oxygen persufflation in combination with UW solution enhances adenine nucleotide contents in ischemically damaged rat kidney during cold storage." Transpl Int **9**(4): 396-402.
- Yoshikawa, T., Y. Suzuki, et al. (2004). "Objective and rapid assessment of pancreas graft viability using 31P-nuclear magnetic resonance spectroscopy combined with two-layer cold storage method." Transplantation **78**(1): 78-82.
- Yotsumoto, G., S. Jeschkeit-Schubbert, et al. (2003). "Total recovery of heart grafts of non-heart-beating donors after 3 hours of hypothermic coronary oxygen persufflation preservation in an orthotopic pig transplantation model." Transplantation **75**(6): 750-756.
- Zhang, P., X. Zhang, et al. (2010). "Global healthcare expenditure on diabetes for 2010 and 2030." Diabetes Res Clin Pract **87**(3): 293-301.
- Zhang, Z. D., F. H. Han, et al. (2005). "Establishment of a pig model with enteric and portal venous drainage of pancreatoduodenal transplantation." World J Gastroenterol **11**(35): 5475-5479.

## **Appendices:**

## **Appendix 1:**



To view this email as a web page, go [here](#).

**Do Not Reply Directly to This Email**

To ensure that you continue to receive our emails,  
please add [rightslink@marketing.copyright.com](mailto:rightslink@marketing.copyright.com) to your [address book](#).

# RightsLink



## Thank You For Your Order!

Dear Mr. William Scott III,  
Thank you for placing your order through Copyright Clearance Center's RightsLink service. Elsevier has partnered with RightsLink to license its content. This notice is a confirmation that your order was successful. Your order details and publisher terms and conditions are available by clicking the link below:

[http://s100.copyright.com/CustomerAdmin/PLF.jsp?IID=2012071\\_1342636276468](http://s100.copyright.com/CustomerAdmin/PLF.jsp?IID=2012071_1342636276468)

### Order Details

Licensee: William E Scott III

License Date: Jul 18, 2012

License Number: 2952060004468

Publication: Cryobiology

Title: Persufflation (or gaseous oxygen perfusion) as a method of organ preservation

Type Of Use: reuse in a thesis/dissertation

Total: 0.00 USD

To access your account, please visit <https://myaccount.copyright.com>.

Please note: Online payments are charged immediately after order confirmation; invoices are issued daily and are payable immediately upon receipt.

To ensure we are continuously improving our services, please take a moment to complete our [customer satisfaction survey](#).

B.1:v4.2

+1-877-622-5543 / Tel: +1-978-646-2777  
[customercare@copyright.com](mailto:customercare@copyright.com)  
<http://www.copyright.com>



This email was sent to: [w\\_scott3@yahoo.com](mailto:w_scott3@yahoo.com)

Please visit [Copyright Clearance Center](http://www.copyright.com) for more information.

## **Appendix 2:**

To view this email as a web page, go [here](#).

**Do Not Reply Directly to This Email**

To ensure that you continue to receive our emails,  
please add [rightslink@marketing.copyright.com](mailto:rightslink@marketing.copyright.com) to your [address book](#).

# RightsLink



## Thank You For Your Order!

Dear Mr. William Scott III,  
Thank you for placing your order through Copyright Clearance Center's RightsLink service. Elsevier has partnered with RightsLink to license its content. This notice is a confirmation that your order was successful. Your order details and publisher terms and conditions are available by clicking the link below:

[http://s100.copyright.com/CustomerAdmin/PLF.jsp?IID=2012071\\_1342635294865](http://s100.copyright.com/CustomerAdmin/PLF.jsp?IID=2012071_1342635294865)

### Order Details

Licensee: William E Scott III  
License Date: Jul 18, 2012  
License Number: 2952050534865  
Publication: Transplantation Proceedings  
Title: Real-Time Noninvasive Assessment of Pancreatic ATP Levels During Cold Preservation  
Type Of Use: reuse in a thesis/dissertation  
Total: 0.00 USD

To access your account, please visit <https://myaccount.copyright.com>.

Please note: Online payments are charged immediately after order confirmation; invoices are issued daily and are payable immediately upon receipt.

To ensure we are continuously improving our services, please take a moment to complete our [customer satisfaction survey](#).

B.1:v4.2

+1-877-622-5543 / Tel: +1-978-646-2777  
[customercare@copyright.com](mailto:customercare@copyright.com)  
<http://www.copyright.com>



This email was sent to: [w\\_scott3@yahoo.com](mailto:w_scott3@yahoo.com)

Please visit [Copyright Clearance Center](#) for more information.

## **Appendix 3:**

To view this email as a web page, go [here](#).

**Do Not Reply Directly to This Email**

To ensure that you continue to receive our emails,  
please add [rightslink@marketing.copyright.com](mailto:rightslink@marketing.copyright.com) to your [address book](#).

# RightsLink



## Thank You For Your Order!

Dear Mr. William Scott III,  
Thank you for placing your order through Copyright Clearance Center's RightsLink service. Wolters Kluwer Health has partnered with RightsLink to license its content. This notice is a confirmation that your order was successful.

Your order details and publisher terms and conditions are available by clicking the link below:

[http://s100.copyright.com/CustomerAdmin/PLF.jsp?IID=2012071\\_1342638525885](http://s100.copyright.com/CustomerAdmin/PLF.jsp?IID=2012071_1342638525885)

### Order Details

Licensee: William E Scott III

License Date: Jul 18, 2012

License Number: 2952070741885

Publication: Transplantation

Title: Pig Pancreas Anatomy: Implications for Pancreas Procurement, Preservation, and Islet Isolation

Type Of Use: Dissertation/Thesis

Total: 0.00 USD

To access your account, please visit <https://myaccount.copyright.com>.

Please note: Online payments are charged immediately after order confirmation; invoices are issued daily and are payable immediately upon receipt.

To ensure we are continuously improving our services, please take a moment to complete our [customer satisfaction survey](#).

B.1:v4.2

+1-877-622-5543 / Tel: +1-978-646-2777  
[customercare@copyright.com](mailto:customercare@copyright.com)  
<http://www.copyright.com>



This email was sent to: [w\\_scott3@yahoo.com](mailto:w_scott3@yahoo.com)

## **Appendix 5:**

To view this email as a web page, go [here](#).

**Do Not Reply Directly to This Email**

To ensure that you continue to receive our emails,  
please add [rightslink@marketing.copyright.com](mailto:rightslink@marketing.copyright.com) to your [address book](#).

# RightsLink



## Thank You For Your Order!

Dear Mr. William Scott III,  
Thank you for placing your order through Copyright Clearance Center's RightsLink service. Elsevier has partnered with RightsLink to license its content. This notice is a confirmation that your order was successful. Your order details and publisher terms and conditions are available by clicking the link below:  
[http://s100.copyright.com/CustomerAdmin/PLF.jsp?IID=2012071\\_1342635577138](http://s100.copyright.com/CustomerAdmin/PLF.jsp?IID=2012071_1342635577138)

### Order Details

Licensee: William E Scott III  
License Date: Jul 18, 2012  
License Number: 2952050817138  
Publication: Transplantation Proceedings  
Title: Pancreas Oxygen Persufflation Increases ATP Levels as Shown by Nuclear Magnetic Resonance  
Type Of Use: reuse in a thesis/dissertation  
Total: 0.00 USD

To access your account, please visit <https://myaccount.copyright.com>.

Please note: Online payments are charged immediately after order confirmation; invoices are issued daily and are payable immediately upon receipt.

To ensure we are continuously improving our services, please take a moment to complete our [customer satisfaction survey](#).

B.1:v4.2

+1-877-622-5543 / Tel: +1-978-646-2777  
[customercare@copyright.com](mailto:customercare@copyright.com)  
<http://www.copyright.com>



This email was sent to: [w\\_scott3@yahoo.com](mailto:w_scott3@yahoo.com)

## **Appendix 6:**



To view this email as a web page, go [here](#).

**Do Not Reply Directly to This Email**

To ensure that you continue to receive our emails,  
please add [rightslink@marketing.copyright.com](mailto:rightslink@marketing.copyright.com) to your [address book](#).

# RightsLink



## Thank You For Your Order!

Dear Mr. William Scott III,  
Thank you for placing your order through Copyright Clearance Center's RightsLink service. Elsevier has partnered with RightsLink to license its content. This notice is a confirmation that your order was successful. Your order details and publisher terms and conditions are available by clicking the link below:

[http://s100.copyright.com/CustomerAdmin/PLF.jsp?IID=2012071\\_1342635633420](http://s100.copyright.com/CustomerAdmin/PLF.jsp?IID=2012071_1342635633420)

### Order Details

Licensee: William E Scott III  
License Date: Jul 18, 2012  
License Number: 2952050873420  
Publication: Transplantation Proceedings  
Title: Persufflation Improves Pancreas Preservation When Compared With the Two-Layer Method  
Type Of Use: reuse in a thesis/dissertation  
Total: 0.00 USD

To access your account, please visit <https://myaccount.copyright.com>.

Please note: Online payments are charged immediately after order confirmation; invoices are issued daily and are payable immediately upon receipt.

To ensure we are continuously improving our services, please take a moment to complete our [customer satisfaction survey](#).

B.1:v4.2

+1-877-622-5543 / Tel: +1-978-646-2777  
[customercare@copyright.com](mailto:customercare@copyright.com)  
<http://www.copyright.com>



This email was sent to: [w\\_scott3@yahoo.com](mailto:w_scott3@yahoo.com)

Please visit [Copyright Clearance Center](#) for more information.

## **Appendix 9:**

To view this email as a web page, go [here](#).

**Do Not Reply Directly to This Email**

To ensure that you continue to receive our emails,  
please add [rightslink@marketing.copyright.com](mailto:rightslink@marketing.copyright.com) to your [address book](#).

# RightsLink



## Thank You For Your Order!

Dear Mr. William Scott III,  
Thank you for placing your order through Copyright Clearance Center's RightsLink service. Elsevier has partnered with RightsLink to license its content. This notice is a confirmation that your order was successful. Your order details and publisher terms and conditions are available by clicking the link below:

[http://s100.copyright.com/CustomerAdmin/PLF.jsp?IID=2012071\\_1342635733704](http://s100.copyright.com/CustomerAdmin/PLF.jsp?IID=2012071_1342635733704)

### Order Details

Licensee: William E Scott III

License Date: Jul 18, 2012

License Number: 2952050973704

Publication: Transplantation Proceedings

Title: Continuous Real-time Viability Assessment of Kidneys Based on Oxygen Consumption

Type Of Use: reuse in a thesis/dissertation

Total: 0.00 USD

To access your account, please visit <https://myaccount.copyright.com>.

Please note: Online payments are charged immediately after order confirmation; invoices are issued daily and are payable immediately upon receipt.

To ensure we are continuously improving our services, please take a moment to complete our [customer satisfaction survey](#).

B.1:v4.2

+1-877-622-5543 / Tel: +1-978-646-2777  
[customercare@copyright.com](mailto:customercare@copyright.com)  
<http://www.copyright.com>



This email was sent to: [w\\_scott3@yahoo.com](mailto:w_scott3@yahoo.com)

Please visit [Copyright Clearance Center](http://www.copyright.com) for more information.