

PRINCIPLES AFFECTING INSULATED BUILT-UP ROOFS

C. E. LUND, M.S. (M.E.)
PROFESSOR AND ASSISTANT DIRECTOR
ENGINEERING EXPERIMENT STATION

R. M. GRANUM, B.M.E.
RESEARCH ASSOCIATE

BULLETIN NO. 34



UNIVERSITY OF MINNESOTA

J. L. MORRILL, President

INSTITUTE OF TECHNOLOGY

A. F. SPILHAUS, Dean

ENGINEERING EXPERIMENT STATION

B. J. LAZAN, Director

May 1952

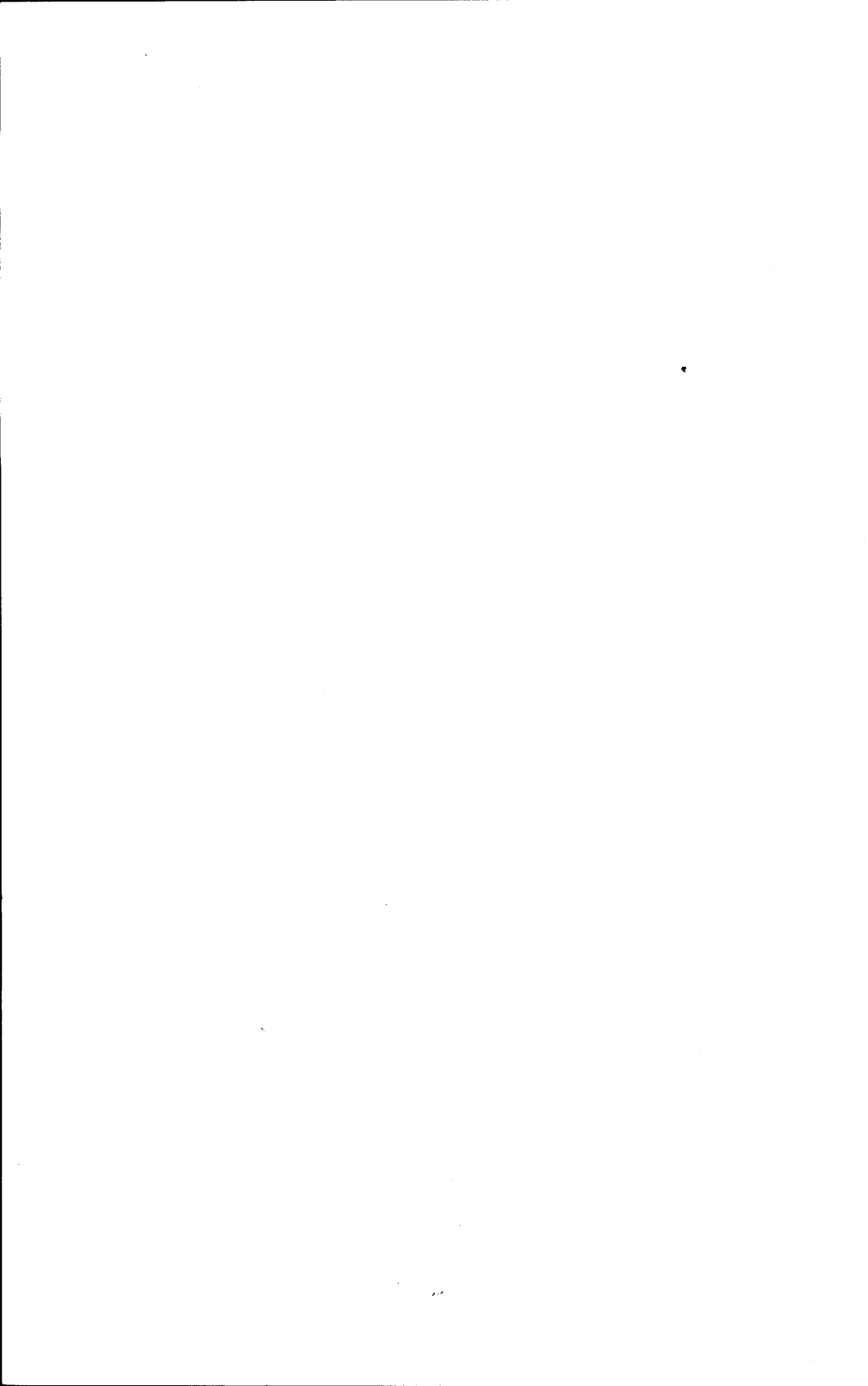

ACKNOWLEDGMENT

The authors gratefully acknowledge the cooperation of the Insulation Board Institute and the assistance of its Technical Committee in the planning, organization, and development of this research program. This committee includes D. B. Anderson, chairman (1951), B. F. Arendt, I. L. Birner, A. S. Bull, P. D. Close, J. H. Conover, R. E. Donnelly, O. W. Frost, chairman (1946), D. L. Gleaves, A. E. Hughes, E. M. Jenkins, chairman (1947 and 1948), J. J. Perot, W. L. Scott, chairman (1949 and 1950), S. M. Van Kirk, technical secretary. We also wish to express our appreciation to Mr. Robert Paul, research fellow, for assisting in the execution of the details of the program and publication of this bulletin.



Table of Contents

	PAGE
I INTRODUCTION	1
Roof Functions	1
Causes of Failure	1
II VARIABLES AFFECTING ROOF CONSTRUCTION	4
Weather	5
Workmanship	5
Materials	6
III TYPES OF ROOF FAILURES	6
Mechanical Failures	7
Construction Failures	7
Roof Blisters	7
Weather Blisters	8
Structural Blisters	8
IV AIR, MOISTURE AND HEAT	11
Air and Moisture	12
Moisture Capacity of Air	12
Pressures Exerted by Air and Moisture	13
Solar Heat	16
V MOISTURE MIGRATION WITHIN ROOF STRUCTURES	17
Roof Surface Condensation	17
Structural Condensation	19
High Inside Relative Humidity	19
Poorly Insulated Roofs	20
Permeable Interior Construction	21
Effect of Materials of High Moisture Content	21
Construction Practices	22
VI THE VALUE OF INSULATION IN BUILT-UP ROOFING	22
Economic Value	24
Resistance to Solar Heat	25
Prevention of Interior Surface Condensation	25

	PAGE
VII RESEARCH STUDIES ON BUILT-UP ROOFS	28
Terminology	28
Test Apparatus	30
Description of Tests and Results	30
Vapor Permeability of Typical Built-up Roofs	30
Vapor Permeability of Typical Vapor Seal Courses	30
Effect of Lapped Joints on the Vapor Permeability of Built-up Roofing and Vapor Seal Courses	31
Effect of Simulated Winter Weathering Conditions on the Vapor Permeability of Roofing	31
Effect of Simulated Summer Weathering Conditions on the Vapor Permeability of Roofing	33
Effect of Combined Simulated Summer and Winter Weathering on the Vapor Permeability of Roofing	34
Effect of Aging on the Vapor Permeability of Vapor Seal Courses	36
Effect of Concrete Decks on the Permeability of Vapor Seal Courses	36
Moisture Migration Within Insulated Roofs	37
Conclusions	42
Field Survey of Roofing Contractors	43
Roof Decks	44
Vapor Seal Courses	45
Roof Insulation	46
Application of Roofing Felt	47
Blistering of Roofs	48
VIII CAUSES AND PREVENTION OF ROOF FAILURES	49
IX CONCLUSIONS	54
APPENDIXES	
Appendix A	59
Appendix B	67
Appendix C	91

List of Tables

TABLE	PAGE
I Air Moisture Content at Various Temperatures and Relative Humidities	13
II Summary of Results of Roofing Contractor Survey for Upper Midwest, Midwestern, and Eastern Areas	47
B-I Weights of Asphalt and Tar Coatings Used in Construction of Built-up Roofing and Vapor Seal Courses	75
B-II Vapor Permeability of 10-Year Built-up Roofing	77
B-III Vapor Permeability of Vapor Seal Courses	77
B-IV Construction Details for Winter Weathering Test Specimens	79
B-V Vapor Permeability of Specimens of Roofing Subjected to Summer Weathering	81
B-VI Vapor Permeability of Roofing Specimens Subjected to Combined Winter and Summer Weathering	82
B-VII Vapor Permeability of Vapor Seal Course Specimens Contained in the Different Roof Structures Subjected to Various Weathering Conditions	83
B-VIII Vapor Permeability Rates and Frost Accumulation in Roof Assembly Specimens	85
B-IX The Effect of Vapor Transmission on Moisture Distribution Within Insulated Roof Decks	86
B-X Moisture Distribution Within Insulated Roofs Subjected to Winter Weathering Conditions	88
B-XI Moisture Content of Insulation in Specimens Subjected to Winter-Summer Weather Test	90

List of Illustrations

	PAGE
Roof Exposure to Weathering Elements	2
Construction of Insulated Roof	4
Roof Application Adjacent to Parapet Wall	5
Structural Roof Blisters with Water Between Felts	9
Structural Roof Blisters Showing Expansion of Felts	10
Structural Blisters in the Form of Alligator Ridges	11
Effect of Heat, Air and Moisture on the Development of Pressures	14
Effect of Solar Radiation on Roof Surface Temperature	16
Effect of Radiation of Heat from Roof Decks on Roof Surface Temperatures on Clear and Cloudy Nights	18
Effect of Vapor Seal Courses on Moisture Migration and Condensation Within Roofs	20
Solid Mopping of Roof Decks	22
Application of Insulation Board to Roof Decks	23
Refrigerated Cold Room Used for Testing Built-up Roofs	29
Interior of Cold Room Showing Roof Specimens Exposed to Winter Weathering Conditions	31
Roof Specimens Exposed to Summer Weathering Conditions	34
Effect of Roof Surface Temperature on Moisture Gradient Within Insulated Roof Decks	41
Solid Mopping of Roofing Felts	49
Pressures Developed Within Roofing Plies as Affected by Heat, Air and Moisture	50
Shearing Action Developed Due to Pressure Between Roofing Plies	51
Temperatures Within a Roof Deck Exposed to Solar Radiation	54

List of Figures

FIGURE	PAGE
1. Pressure, Temperature Relationship for Dry and Vapor Saturated Air	15
2. Effect of Insulation Board on Reducing the Heat Flow Through Different Types of Decks	24
3. Effect of Insulation Board on the Maximum Relative Humidity That May Be Maintained at 70° F Within a Building Without Surface Condensation	26
4. Maximum Inside Relative Humidity Which May Be Maintained at 70° F Without Surface Condensation for Different Types of Decks Constructed with Different Thicknesses of Insulation Board at an Outside Air Temperature of 20° F	27
5. Effect of Vapor Barrier on Moisture Redistribution Within Roofs	40
6. Effect of Vapor Barriers of Different Permeabilities on Moisture Accumulation Within Insulation	40
A-1. Plan View of Vapor Permeability Test Apparatus	59
A-2. Sectional View of Vapor Permeability Test Apparatus	60
A-3. Vapor Permeability Test Assemblies for Individual Specimens	60
A-4. Vapor Permeability Test Assemblies as Viewed from the Cold Side	61
A-5. Vapor Transmission Apparatus for Testing Built-up Roof Sections	63
A-6. Winter Weathering Specimens Subjected to Infra-Red Radiation	63
A-7. Construction of Roof Test Sections	64
A-8. Roof Specimens Exposed to Summer Weathering	65
A-9. Summer Weathering Test Apparatus	65
B-1. Roofing Panels 1 and 1-A	68
B-2. Roofing Panel No. 2	69
B-3. Roofing Panel No. 3	70
B-4. Roofing Panel No. 4	71
B-5. Vapor Seal Course Panel 1-V	72
B-6. Vapor Seal Course Panel 2-V	73
B-7. Vapor Seal Course Panel 3-V	74
B-8. Vapor Seal Course Panel 4-V	76
B-9. Effect of Roof Surface Temperature on the Moisture Gradient Within Insulated Roof Decks	89

ABSTRACT

The majority of built-up roofs either insulated or noninsulated have given continued and satisfactory performance. Field surveys have shown that failure of roofs due to blistering is less than 5 per cent of the total number of roof installations. Although this appears to be minor in comparison with the large number of roofs giving satisfactory performance, the industry is constantly striving toward improvement in performance and the avoidance of any possible failures irrespective of their causes. Ultimate perfection is desired, but the introduction of new designs in roof construction requires the re-evaluation of the new problems as they occur. This publication covers the findings of five years of research on insulated and noninsulated built-up roofs, which was conducted at the Engineering Experiment Station, University of Minnesota, in cooperation with the Insulation Board Institute. The program included the investigation of types and causes of roof failures; variables affecting roof construction; the effects of air, moisture and heat upon roof performance; moisture migration within roof structures; and the economic value of roof insulation. These laboratory studies were substantiated by an extensive field survey of the major roofing contractors in various sections of the United States.

The various types of roof failures have been classified into mechanical, construction, and roof blistering. Mechanical failures cover traffic, mechanical equipment, ventilators, etc. Construction failures include inferior materials, poor workmanship, and the lack of quality control in the field. Roof blisters have been classified as weather and structural blisters. Weather blisters are the result of natural weathering of the roof surfaces. Structural blisters occur in many types of deformation of the roofing plies and are caused mainly by the expansion of air and water vapor.

The principal conclusions resulting from this investigation are as follows: importance of good workmanship and field control governing roof specifications and materials; construction of roofs according to the approved and accepted specifications; the use of vapor seal courses over all roof decks in cold climates and in temperate climates wherever conditions of high inside humidity exist; solidly mopping the plies of roof felts; avoiding the use of roofing materials having a high moisture content; avoiding roof application during inclement weather or upon a deck which is not thoroughly dry; exercising rigid control over the temperature of the bitumen; thoroughly brooming down all felts as quickly as possible following the application of the bitumen; and utilizing special precautions when applying roofs to uncured concrete decks to prevent any moisture from entering into the roof structure.

Principals Affecting Insulated Built-up Roofs

I. INTRODUCTION

Built-up roofing has been subjected to relatively little searching study in the past, yet it is required to perform a most important function in all types of building structures.

Considerable emphasis has been placed on improvements in architectural design, wall construction, and other elements of the building field. While the resultant changes have been generally beneficial, many of these improvements, by their very nature, create problems which demand special attention. For example, it has been found that the use of wall insulation often requires that a vapor barrier be installed to prevent excessive moisture accumulations within the wall. These are but two of the many parts of the building structure which have been given special consideration. The design and construction of the built-up roof have not benefited by the same searching analysis.

ROOF FUNCTIONS

What is the important functional use of a built-up roof or of any other type of roof? The question is one which must be answered before the significance of roof failure can be properly appreciated. Briefly, its function is to serve as a permanent protection for the structure itself while providing for the comfort of the occupants and the protection of valuable property. It must fulfill these requirements while withstanding the elements of the weather: wind, rain, hail, snow, ice, extremes in temperatures, or any combination thereof, and with a degree of permanency equivalent to that expected of the entire structure.

CAUSES OF FAILURE

Causes of roof failures can be broken down into two categories, namely, controllable and uncontrollable. Needless to say, the demarcation lines between the two classifications are not sharply



Roof Exposure to Weathering Elements

drawn, and we shall see that the word "control," as applied to factors of roof construction, is at best a relative term.

In the first of these categories, the factor of traffic on the roof is important. Such traffic occurs as a result of any number of reasons: special installation of roof ventilators, special service wiring, additional outlets in the roof, or maintenance equipment which can be reached only by workmen walking on the roof, are a few of the many reasons. This traffic may cause roof failures soon after installation or it may cause a series of progressive failures resulting from a single initial failure which has not been immediately repaired.

High inside humidity is another controllable factor which is sometimes responsible for shortening the life of a roof. With modern methods of design, tightness of construction has reached a point where, especially in smaller buildings, high relative humidity may be built up due to moisture given off by the occupants.

The problem is even more serious when the structure is used for such enterprises as wood pulp manufacturing, flour milling, paper manufacturing, cotton processing, or similar industries which tend to produce excessively high indoor humidities. In larger and more costly buildings, air conditioning equipment is being installed to maintain constant temperature and humidity.

The remaining controllable factors which can influence the durability of a roof are the standards of construction practices and the quality of materials used. It is clear that these are fundamental values. If the roof is not well constructed with high quality material, no amount of care or maintenance thereafter can be substituted for its original shortcomings.

This brings us to a more difficult problem: that of factors which are largely uncontrollable, but which nevertheless play an important role in assuring the satisfactory performance of a roof. The roofing industry is one of the few in which technological advancement has been unable to materially assist in mechanization of construction tasks. Improvements have been introduced in certain types of equipment used, but the greater part of the work must be performed by hand labor.

Thus, the quality of the completed roof is largely dependent upon the human element, which may be extremely difficult to control. Proper heating of the bitumen, mopping of the roofing felts, and the condition of the roof deck are all elements which are subject to human error.

Weather is the most clearly uncontrollable factor in roof construction. To make this problem worse, the builder is seldom in a position to coordinate his work with the vagaries of nature. One of the greatest problems a roofing contractor must experience is the demand for immediate installation of the roof deck regardless of the weather or the condition of the roof deck.

From the preceding discussion, it is apparent that the construction of a quality roof which is ready to meet the many demands imposed upon it is not merely a mechanical process, but one requiring a considerable amount of thought and experience. The evaluation of all factors entering into the construction of an insulated built-up roof shows that the responsibility of obtaining a roof of quality and durability rests upon the general contractor, the roofing contractor, the engineer and the architect, as well as the manufacturers of the necessary materials.

Becoming familiar with the fundamental principles affecting the performance of built-up roofs is the prime prerequisite in obtaining a roof which will give satisfactory performance and long life at a minimum of maintenance expense. In order to understand these fundamentals, a detailed analysis of each of the factors will be given. These analyses are based upon the re-

sults of five years of research and are supplemented with field investigations carried on at the Engineering Experiment Station, University of Minnesota, in cooperation with the Insulation Board Institute, Chicago, Illinois.

II. VARIABLES AFFECTING ROOF CONSTRUCTION

Many roofing contractors are able to look back on their own experiences and recall roofing jobs where "the best made plans" were upset because the weather suddenly turned bad, or new workmen were unfamiliar with their job, or some other equally unforeseeable event interfered with construction. Obviously, there is no formula for dealing with these events. They can occur at any moment in dozens of combinations.

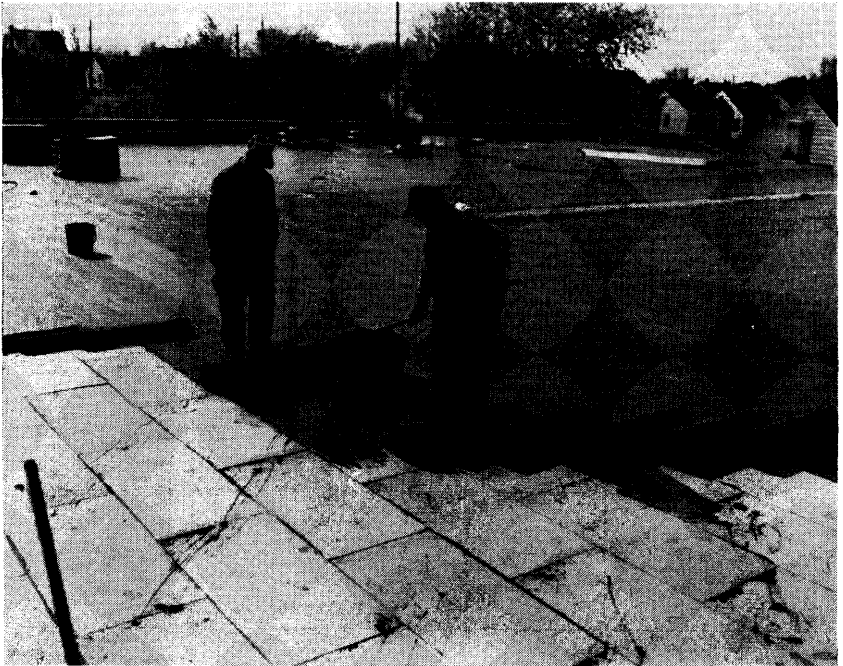

Construction of Insulated Roof

The best protection against such occurrences is familiarity with them. Since it is clearly impossible to list and classify all the possible variables with which the roofing contractors may meet, the following discussion is limited to a review of variables as caused by weather, workmanship, and materials.

WEATHER

The weather factor makes the task of the roofer one of the most difficult in the building industry. The roofing contractor is not in a position to wait until weather conditions are favorable, since the building shell, once erected, must be protected from the weather. Also, the actual application of the roofing is often hurried to provide protection for the crews of interior workmen. The roofing contractor must, in the face of these conditions, strive to make the roof application as successful as possible, since imperfections in the roofing application are not only readily recognizable, but worse, they may result in serious damage to the building and its contents. Laxity in roof construction cannot escape notice over a long period of time.

WORKMANSHIP

During the last quarter of a century, the general building industry has initiated revolutionary changes in design and methods of construction. However, it has been impossible to mechanize the building field on a production line basis. Consequently, this industry is mainly dependent upon the ability and experience of

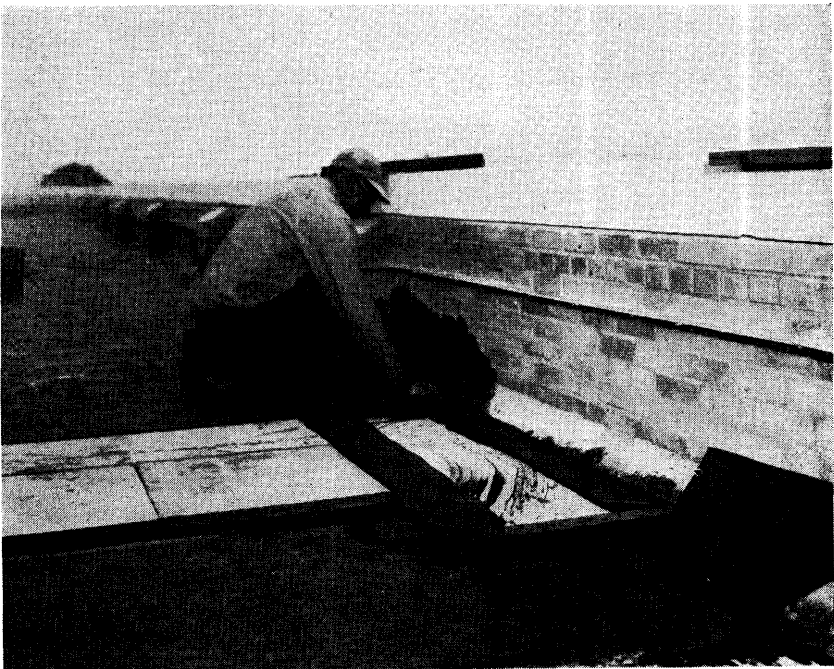

Roof Application Adjacent to Parapet Wall

skilled and semi-skilled laborers who spend their lives at this type of work. Many building contractors are now striving to introduce new methods of construction and techniques in order to reduce their dependence upon the unpredictable human element. Inevitably, a certain amount of variation will persist; however, with continuing improvements in methods and equipment, this variation can at least be confined within reasonable limits.

MATERIALS

The quality of building materials constitutes a factor which profoundly affects the performance of a structure. Since these materials are, in most instances, produced under favorable conditions of quality control, the contractor's responsibility lies in assuring proper handling and storage of the materials after they have been received from the manufacturer or the dealer. However, there are cases where the quality of the building material is governed by the availability of the required raw materials, demand, and the economic value. In such cases, it becomes the contractor's responsibility to be aware of changes in the quality of materials and to take counteractive measures wherever necessary or possible.

In review, three factors, *workmanship*, *weather*, and *materials*, are considered to be of primary importance in governing the performance of building construction. The degree to which these factors may be controlled is a determining influence on the life of a building or roof.

III. TYPES OF ROOF FAILURES

The performance of a roof or roof structure is dependent upon a number of factors, some of which are interrelated and others which have an individual effect. This discussion is not confined solely to the combination of roofing plies but also considers the type of deck or insulation incorporated into its design. For the purpose of clarification, the following terminology will be used in this publication:

1. **Roof or Roof Structure**—The term applies to the over-all complete structure and includes the roofing, insulation, vapor seal course and deck.
2. **Roofing or Built-up Roofing**—Applies to the plies of felt which have been mopped either directly to the roof deck or to the top of the insulation board whenever it is specified.
3. **Deck**—The foundation upon which the insulation and roofing is applied.

4. **Vapor Seal Course**—The solid mopping of specified layers of felt to the deck for the prevention of migration of moisture or water vapor from the warm side.
5. **Perms**—The term generally adopted to designate the rate of vapor permeability through a material or combination of materials. Perm = 1 grain per square foot per hour per inch of mercury vapor pressure difference.

MECHANICAL FAILURES

The most common types of failures which occur are those caused by fractures or punctures resulting in holes in the plies of the felt. The roofing industry is well aware of the causes of these failures and the means of overcoming them. Fracture of the roofing may be caused by traffic, mechanical equipment, expansion and contraction of flashing applied to parapet walls, ventilators and other similar projections in the roof. These failures may be classified as mechanical failures and are readily recognized by the experienced roofer. Repairing these fractures is not difficult and is usually considered a part of the roof maintenance.

CONSTRUCTION FAILURES

Other failures are those resulting from improper roof construction or inferior materials. These may appear within a very short time following the completion of construction and may require a reapplication of the entire roof. They may be the result of poor quality workmanship, lack of field control, improper equipment, lack of experience, inferior materials, or the conservation of bitumen which results in inadequate mopping of the felts. Improper roof design may also be a contributory cause.

The foregoing types of failures result in the entrance of free water into the roof structure through the top surface with the result that water leaks or drips into the interior of the building. Such leaks occur during periods of rain, or following the thawing of ice or snow which has accumulated on the roof. The latter occurrence should not be confused with interior condensation which also may simulate a leaky roof during certain periods of the year following an interval of cold weather. Further discussion on this subject will be presented later.

ROOF BLISTERS

The most difficult failures to understand are those caused by roof blisters. The term "roof blistering" is commonly used in the roofing industry to describe certain types of roof failures. It has been applied to many types of deformations in the roof surfaces

where the failure of roofs has occurred. The causes of roof blistering are least understood and the most difficult to evaluate because of the many intangible factors involved. Yet, it is with this subject that we are primarily concerned and about which little or no information has previously been made available.

Before we are able to analyze the causes of "roof blistering" and its effect upon the failure of roofs, it is necessary to differentiate between the types of blisters which occur. Certain types of blisters are harmless and others may cause a considerable amount of damage. For the purpose of clarity, blisters will be classified as *weather blisters* and *structural blisters*.

Weather Blisters

Weather blisters occur on the surface of the bitumen which forms the final coating or final mopping of the roof and the blisters are generally identified by the roofing industry as "blueberries." These are usually small surface blisters which are confined to the roof surface. They are small in area and can be seen in large numbers over the entire area of the roof. These blisters are the result of the natural weathering of the roof surface and are more predominant during warm weather or where roofs are exposed directly to the rays of the sun. Temperatures of 170° F to 180° F are not uncommon on roof surfaces where a combination of high air temperature and maximum sun exposure occurs. This heat causes an expansion of the bitumen surface and also the generation of some of the volatiles of the bitumen into gases which cannot escape. The formation of these gases in turn causes small blisters to appear whenever the strength of the film surface of the bitumen is greater than the pressure created to cause the blisters. Likewise, minute quantities of air may be temporarily trapped in the film surface which will also expand and cause the same condition. Thus, these small blisters are more apparent during warm, sunny periods and less apparent during cool, cloudy periods. As stated before, this type of blistering is expected as the result of natural weathering or wear and usually does not cause any failures during the normal life of the roof. When failures do occur, it is then necessary to resurface the roof.

Structural Blisters

These are the types which result in roof failures and are most difficult to evaluate as to their causes. They are different from "weather blisters" in that they are found within the roofing plies and do not occur only at the surface or in any particular confined area. Weather blisters are confined to the exposed surface of the roofing consisting of the final coating of the bitumen only. Structural blisters occur in many forms of deformation of the built-up



Structural Roof Blisters with Water Between Felts

roofing plies and are caused mainly by the expansion of trapped air and water vapor or moisture or other gases which may be given off by the felts. Air trapped within the built-up roofing during construction tends to expand during a rise in air temperature or from the heat of the sun. As the roofing is a sealed unit, this expansion causes the plies of the roofing to separate and to bulge the roof surface in a balloon effect. Similarly, moisture or water occurring within the felts or between the felts will evaporate and form vapor which creates a pressure rise with an accompanying increase in volume to form these balloon effects. Structural blisters are usually spongy and are considerably larger than weather blisters. The area involved may be small or large and the blistering or ballooning of the felts is usually greater during periods of warm weather and further exaggerated when the roof is exposed to the sun's rays. The blisters subside or decrease during a decline in temperature. Whenever these blisters are punctured during periods of maximum inflation, the gas will escape and the roofing plies will return to their original position, providing they have not already been permanently deformed by the pressure. There is a noticeable sound of gas or air escaping when this puncturing takes place.

The blisters may occur between any of the layers of roofing felts, depending upon the number of plies in the roof. For example, they may occur between the deck and the first ply of felt, between the first and the second plies, the second and the third and so forth, depending upon the adhesion between the different plies. If expansion of the air or gases originates between the deck and the first ply of felt or directly above the roof deck, the expansion may continue through various channels formed between the upper plies which are not solidly mopped or do not have positive adhesion. This will continue on through the upper layers of felt until the gas finds an avenue of escape. If no escape is available, the result is blistering or ballooning of the roofing plies. When the gas has no avenue of escape, the expansion of felts may also take place until it exceeds the rupture strength of the material at which point the roofing fails. The resultant opening allows external water to enter which may then in turn set up a series of further expansions in a similar cyclic action to produce widespread roof damage.

In many cases the roof surface is not ruptured due to the fact that insufficient pressure exists. However, in such cases, the stress produced by the pressure may be sufficient to cause a permanent elongation or stretching of the roofing felts. Upon a decrease in



Structural Roof Blisters Showing Expansion of Felts

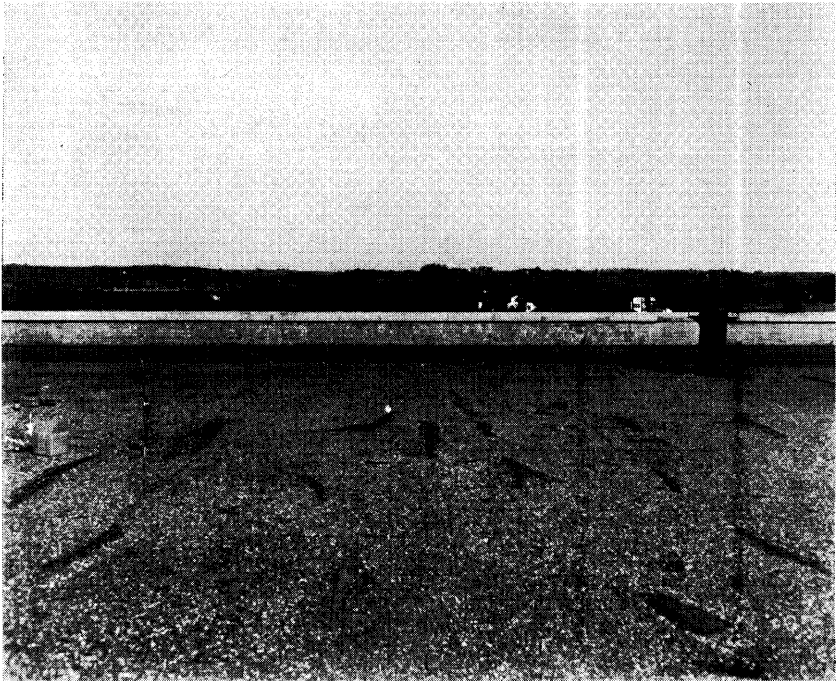

Structural Blisters in the Form of Alligator Ridges

temperature, and consequent reduction in pressure, the roofing will not completely return to its original position. Due to the permanent stretching of the felts, "alligator ridges" will be formed. These ridges vary in size and length, depending upon the extent of pressure developed to cause stretching of the material, and do not necessarily indicate loss in water-tight integrity of the roof. However, the ridges make the roof far more vulnerable to puncture, and erosion of the surface mopping from the raised sections will eventually lead to roof failure.

IV. AIR, MOISTURE AND HEAT

Air, moisture and heat are elements which are ever-present within and without every roof structure. To ignore their presence and the hazards which, under certain conditions, they can create, is to invite failure in roof construction. On the other hand, recognition of their potential destructive power will enable the roofing contractor to take adequate measures for their control.

How are these three elements directly or indirectly respon-

sible for roof failures? Before this question can be properly answered, the inherent characteristics of the three elements must be understood.

AIR AND MOISTURE

The air that we normally breathe contains moisture in the form of water vapor. The amount of moisture that is present in the air varies, of course, from day to day or even from hour to hour. Water vapor in the air is usually designated as *relative humidity* within the normal range of air temperatures. It is similar to steam at low temperatures and pressures, and has the same characteristics as a gas. Moisture is generally not visible in the air under normal conditions, as the air is only partially saturated with water vapor. When the air is fully saturated with moisture and contains the maximum amount of water which it can hold at its specific temperature, the addition of any more moisture will cause the water vapor to condense out in the form of a fog or mist. At high temperatures, air can hold more moisture than at low temperatures. For example, on foggy nights the fog will often be seen only in the lower portions of the countryside. This is due to the fact that air temperatures are lower in these "pockets" or hollows, and the air is unable to retain all of the moisture. The moisture which is condensed out in the form of liquid water is known as "free water." This is comparable to wringing out a moist cloth; the water that appears when the cloth is squeezed is free water.

The significance of the above described characteristics of air and moisture to the functions of a built-up roof are apparent when we consider that any roof is apt to be subjected to conditions of low outside temperatures and warm inside temperatures. If the inside air is heavily laden with moisture, it will, upon contacting the cold inside surface of the roof, have to give up some of its moisture. Over a long period of time, the amount of free water that will condense on the inner surface of the roof may be considerable in amount. This subject will be discussed in detail in the following sections.

Moisture Capacity of Air

Table I shows the relationship between the temperature of a given amount of air and the amount of water vapor which it can hold. Taking an example from Table I, one cubic foot of air at a temperature of 170° F can hold 112 grains of moisture or water vapor, whereas one cubic foot of air at 66° F can hold only 7 grains. Due to the small quantities of moisture involved, the term "grains" is used with 7000 grains equaling one pound. When

TABLE I
Air Moisture Content at Various Temperatures and Relative Humidities

Air Temperature Deg F	Amount of Water Vapor in One Cubic Foot of Air		
	100 per cent R H	50 per cent R H	25 per cent R H
170	112 grains*	56 grains	28 grains
139	56 grains	28 grains	14 grains
113	28 grains	14 grains	7 grains
88	14 grains	7 grains	3.5 grains
66	7 grains	3.5 grains	1.8 grains
46	3.5 grains	1.8 grains	0.9 grains
28	1.8 grains	0.9 grains	0.4 grains
13	0.9 grains	0.4 grains	0.2 grains

* 7000 grains = 1 pound.

air at any temperature contains all the water vapor which it is capable of holding, it is said to be saturated or to have 100 per cent relative humidity. For all practical purposes, it can be said that air which contains half the amount of water vapor which it is capable of holding is 50 per cent saturated or has a relative humidity of 50 per cent. For each change in temperature, the total quantity of moisture the air can hold changes. Using Table I, and assuming that one cubic foot of air at 170° F is saturated and is then cooled to 66° F, the air would have to give up 105 grains of moisture (the difference between 112 grains at 170° F and 100 per cent relative humidity and 7 grains at 66° F and 100 per cent relative humidity). Again, if the 170° F air is only 50 per cent saturated, or has a relative humidity of 50 per cent, the air could be cooled to 139° F without any loss of moisture. Air at 139° F and 100 per cent saturation (100 per cent relative humidity) can hold 56 grains or 50 per cent of the amount at 170° F. If the air temperature were then further lowered to 66° F, the one cubic foot of air would have to give up 49 grains of moisture. When this occurs in the outdoor atmosphere, the result would be fog or rain, or, at lower temperature levels, sleet or snow.

If saturated, warm air should come in contact with a surface of a lower temperature than the air, moisture will condense on this surface. This condensation is usually recognized as dew or "sweating," as for instance on the surface of cold water pipes in humid basements. It will be seen that this characteristic of air and moisture plays a profoundly important role in the performance of a built-up roof. It is of the greatest significance during both the construction and normal life of a roof structure.

Pressures Exerted by Air and Moisture

Another important property of air and moisture is the pressure which they develop upon being heated in a confined space. A special characteristic of gases (air and water vapor are consid-

ered gases) is that when they are confined or intermixed within the same space, the total pressure exerted is the sum of the two independent pressures of the air and the water vapor. For this reason moisture or air trapped within a roof structure will cause a considerable pressure when sun exposure produces a high roof temperature. Both air and moisture must be taken into consideration when evaluating the effect of pressure upon the blistering of a roof covering.

If dry air alone, that is, air without any moisture present, is confined within a space at atmospheric pressure and then heated from a temperature of 70° F to a temperature of 150° F, the increase in pressure will be 2.2 pounds per square inch. However, if, for every cubic foot of confined space, approximately 1/6 of an

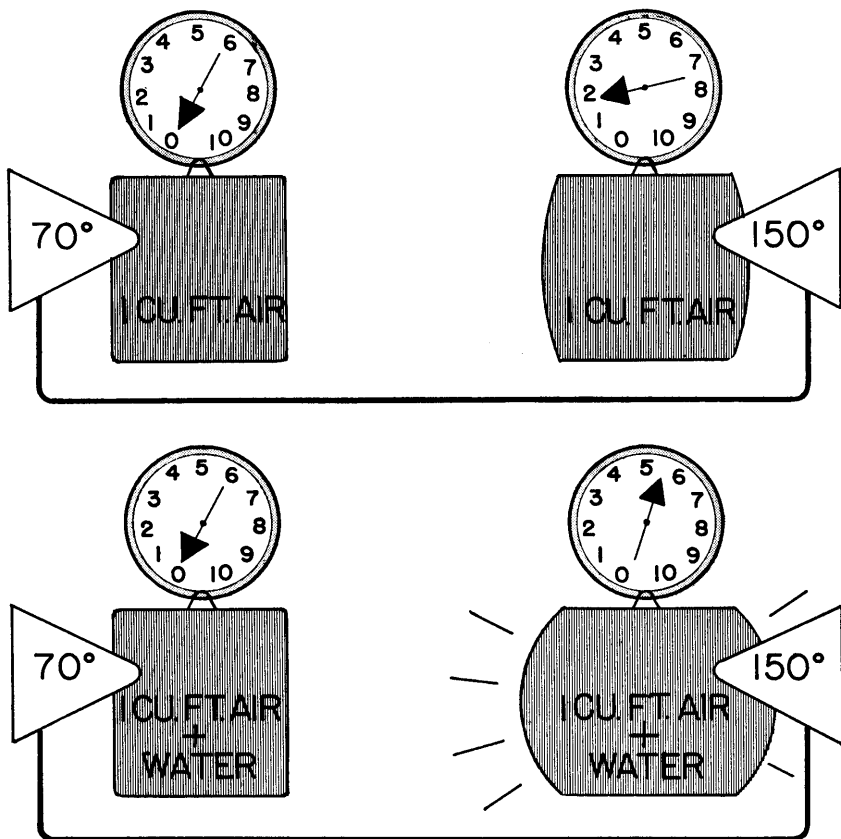

Effect of Heat, Air and Moisture on the Development of Pressures

ounce of water (76 grains of moisture) is added, the pressure increase will be 5.6 pounds per square inch. The presence of the moisture more than doubles the existing pressure in exerting its own pressure of 3.4 pounds per square inch. Figure 1 shows the pressure increase for air and water vapor as well as the total pressure rise from 60° F to 170° F. This indicates the importance of the presence of moisture within a roof structure and its effect in causing blistering.

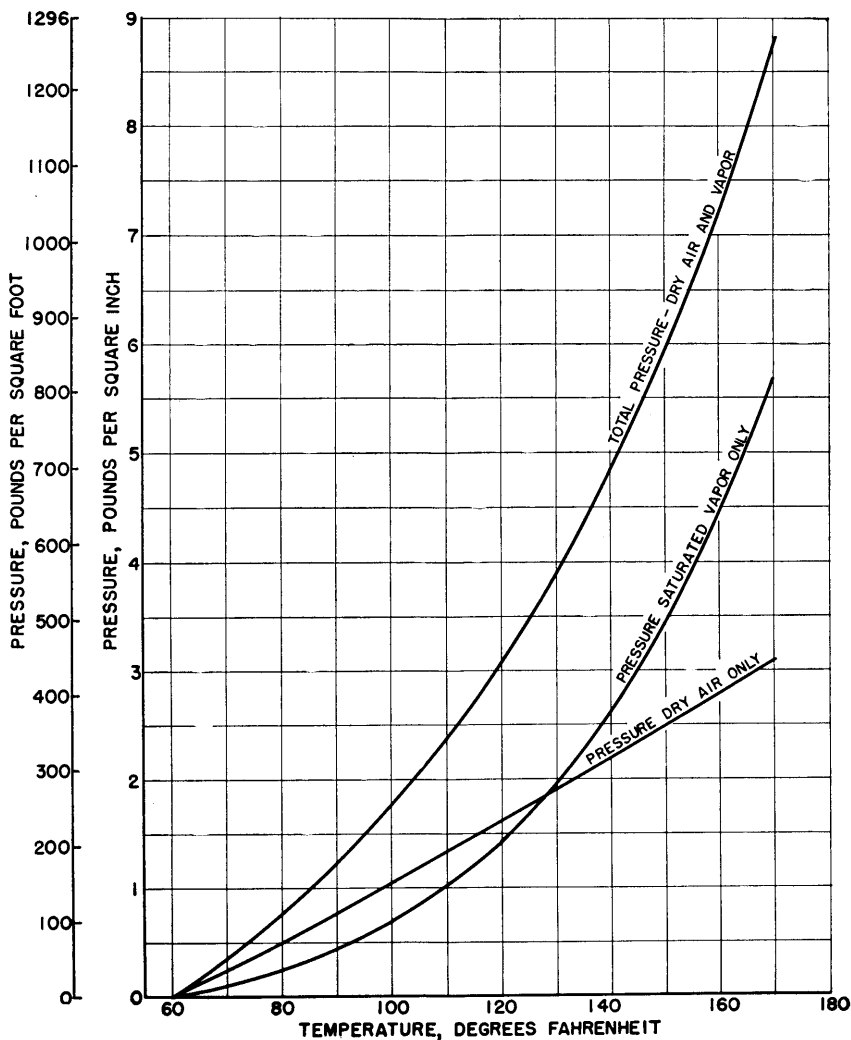
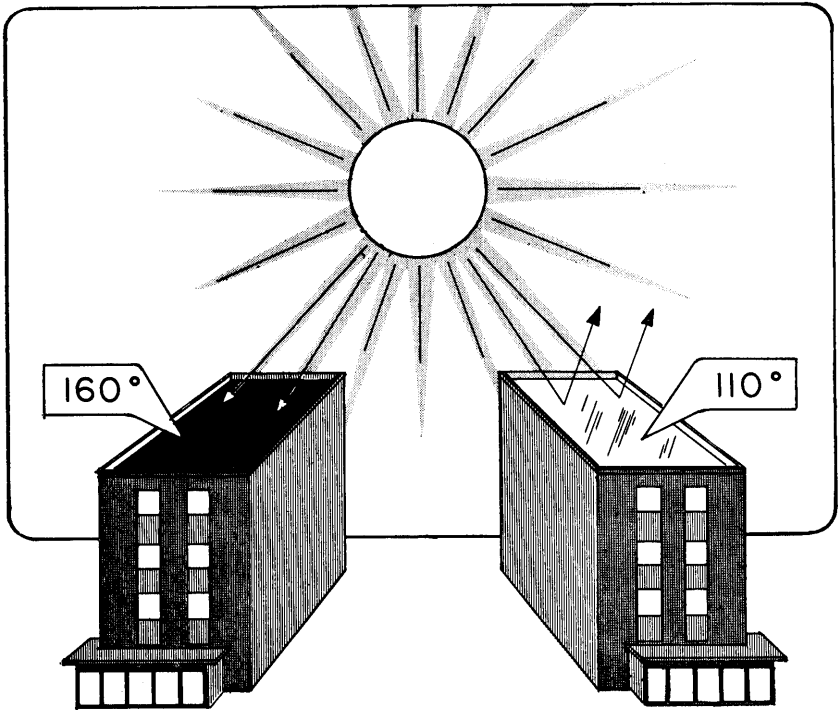

Figure 1. Pressure, Temperature Relationship for Dry and Vapor Saturated Air

SOLAR HEAT

Thus far, the discussion has been confined to describing means by which moisture may enter a roof during construction and to showing that moisture and air, when trapped in a roof structure and heated, will produce a pressure which may cause separation of the roofing plies and blistering. Temperatures sufficiently high to produce pressures of serious consequence result when the



Effect of Solar Radiation on Roof Surface Temperature

outside air temperature is high and when the roof is exposed directly to the sun's rays. Roof surfaces, because of their black color, commonly attain temperatures far higher than the surrounding air temperatures during periods of exposure to the sun's rays. The amount of heat absorbed from the sun on any surface is dependent upon the angle of the sun's rays and the color of the surface. The temperature of a dark-colored or black surface may rise 70° to 80° above the outside air temperature, whereas the temperature of a light-colored surface may rise only 20° to 30° . During the summer months, black roof surfaces attain temperatures of 150° F to 170° F. Thus it is apparent that roof tempera-

ture extremes may far exceed extremes in temperature of the surrounding air, reaching 70° F to 80° F above air temperatures under certain conditions.

In the foregoing sections, the fundamental characteristics of air, moisture and heat, and some of the relationships existing between them have been discussed. It is apparent that these three elements are capable of causing damage within a roof structure only when existing in certain combinations. That is, a roof is subjected to the heat of the sun and high air temperatures during much of the year with no resultant damage. However, if, in addition to this heat, there is air and moisture present within the roof, the pressures generated by the combination of these elements are apt to cause failure of the roof.

V. MOISTURE MIGRATION WITHIN ROOF STRUCTURES

In exceptional cases, built-up roofs constructed with high standards of workmanship and according to time-proven specifications have failed within the expected life of the roof. It is the purpose of the following discussion to analyze the factors which contribute to a short roof life and thereby aid the conscientious roofing contractor in avoiding such conditions.

As previously discussed, roof failures may be the result of a number of causes, some of which are readily recognizable and others which do not appear to have any logical solution. In the latter category are those failures evidenced by structural blistering of the roof and it is with this type of failure that we are primarily concerned.

ROOF SURFACE CONDENSATION

When a built-up roof structure is left partially completed at the end of a work day, the factor of exterior surface condensation upon the roof deck becomes important. The practical result of such an occurrence may well be that the uncompleted roof is covered the next morning with "dew." This type of moisture condensation is well known, but the conditions conducive to such condensation are generally not so well understood.

Surface condensation on roof decks or other parts of the roof during construction usually occurs in the early morning hours when the roof decks are cooled below the surrounding air temperature; in other words, when the surface temperature of the roof deck is below the dew point temperature of the air. The cooling of the roof deck takes place on clear nights as a result of heat

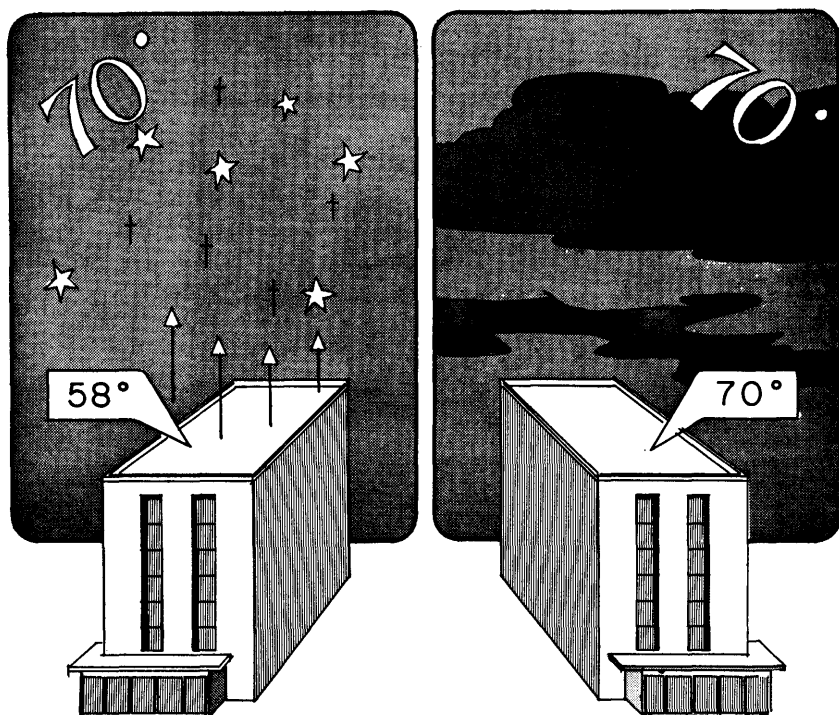

Effect of Radiation of Heat from Roof Decks on Roof Surface Temperatures on Clear and Cloudy Nights

being radiated from the warm roof surface to the interstellar spaces. On such nights surface temperatures 10° to 14° below the surrounding air temperature may be expected. On cloudy nights this phenomenon does not occur because the clouds intercept the heat exchange. When nights are clear but a reasonable wind is prevailing, the magnitude of this condensation is reduced. The wind tends to accelerate the heat exchange between the air and the roof to replace the heat from the roof which is lost by radiation. If the wind velocity is sufficiently high, no condensation may take place as the heat from the air will maintain the roof temperature approximately equal to that of the surrounding air.

Assuming an outside temperature of 70° F, and referring to Table I, air at 70° F and 100 per cent relative humidity contains 8.0 grains of moisture per cubic foot. If the roof deck cools to 58° F, the air adjacent to the deck will cool to 58° F. Air at 58° F can hold only 5.4 grains of moisture per cubic foot. As a result, condensation of the surplus moisture on the roof deck will occur.

Normal circulation of the air will result in a replacement of

the 58° air by another quantity of moisture-laden 70° air, and the condensation will continue. Thus the air currents move over the cold surface with a continuous deposition of moisture. Unless precautions are taken to prevent this condensation, or unless sufficient time is allowed to permit the roof to dry before resumption of construction operations on the following morning, the moisture that has been deposited during the night will be sealed within the roofing plies.

STRUCTURAL CONDENSATION

Structural condensation, as its name implies, is simply condensation within a built-up roof structure. Vapor within a building is not confined to contacting the interior surfaces of glass, walls or ceiling. On the contrary, it may penetrate into the interior parts of the roof structure and walls, and will pass through some materials very readily. In cold climates as vapor passes outward through a wall or roof structure, the vapor will come in contact with colder materials, and a condition may occur where the dew point temperature of a vapor in a given part of the wall is above the temperature of the material with which the vapor is in contact. Under these conditions condensation will take place, and free moisture or frost will be formed within the wall or roof structure, depending upon the temperature.

The conditions which cause condensation within the roof structure are no different from those which cause condensation on interior surfaces. The temperature of the material must be below the dew point temperature of the air in contact with it. Within walls or roofs such condensation is difficult to predict or analyze because there is at present no method by which the vapor density within a roof structure may be calculated with any degree of certainty, even though the vapor conditions on both sides of the roof are known. However, surface condensation on interior surfaces of walls or ceilings may be overcome by calculating the amount of insulation required for a specific condition.

High Inside Relative Humidity

There has been a tendency in recent years to increase the relative humidity of the inside air. This has been brought about partially by the many advocates of higher relative humidities for health purposes. It has resulted both in artificial humidification for many buildings and in the use of construction practices such as weatherstripping which reduce the air infiltration into a building. Lack of air infiltration allows a high relative humidity to build up from natural sources within the building. Certain industrial processes have also created demands for high controlled inside humidities.

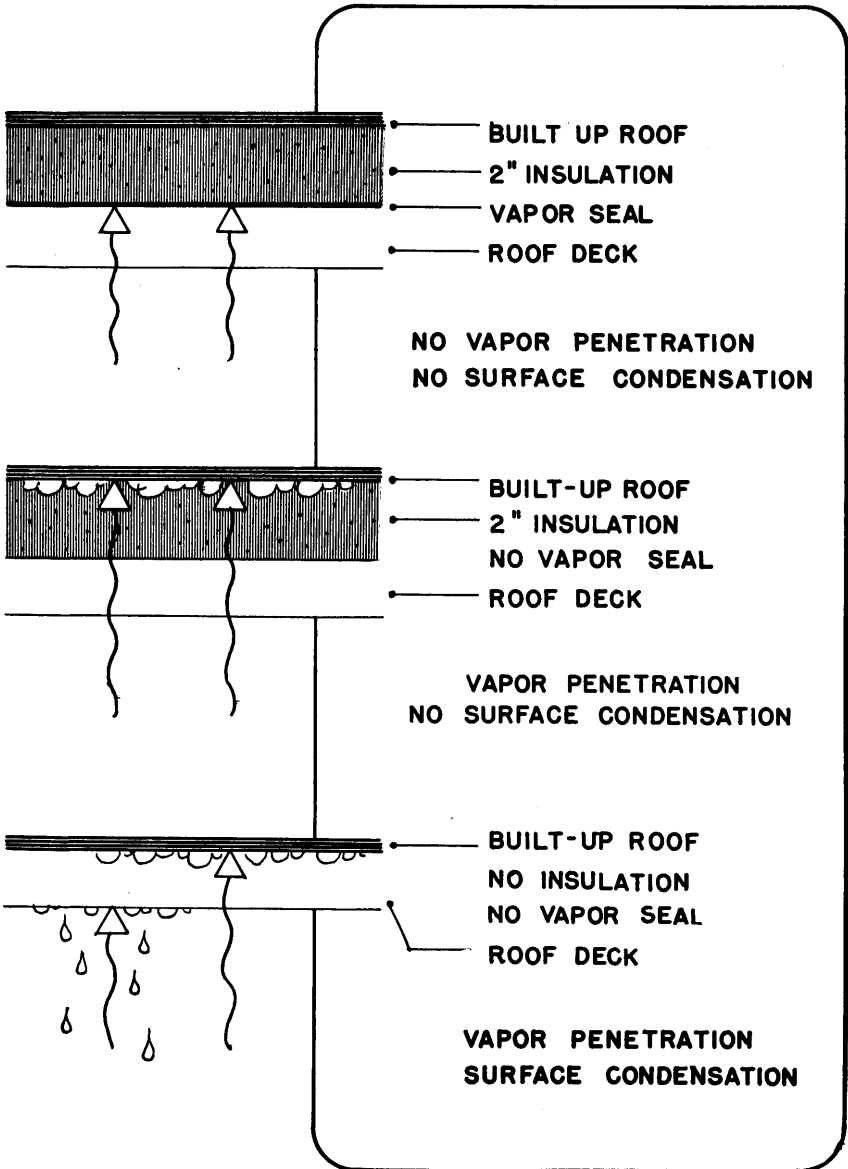

Effect of Vapor Seal Courses on Moisture Migration and Condensation Within Roofs

Poorly Insulated Roofs

There has been a definite increase in the use of roof insulation in recent years which reduces the possibility of condensation on the interior surfaces of ceilings. A point which has often been

obscured is that the addition of insulation to roofs warms the inner surfaces, but cools the materials in the exterior parts of the roof. If the vapor is allowed to penetrate into the roof, there is a greater possibility of condensation within insulated than within uninsulated roofs. This fact has often led to the criticism that insulation is the cause of condensation. Insulation is not the cause of condensation but is an important factor in the conservation of heat. The addition of insulation, however, requires that special precautions be exercised to prevent interior moisture from entering the cold roof section.

Permeable Interior Construction

Experience has shown that condensation of moisture is not peculiar to any basic type of building construction. However, because of the visible changes brought about by modernization of building design, the tendency has been to lay the blame on the type of construction. Materials commonly used as interior finishes, with a few exceptions, transmit water vapor very readily. By supplementing the interior finishes with an approved type of vapor barrier or material of high resistance to vapor transmission, condensation within a wall or roof structure can be eliminated.

EFFECT OF MATERIALS OF HIGH MOISTURE CONTENT

Roofing felts and insulating materials are normally dry; that is, when they leave the manufacturer, they do not have a high enough moisture content to have an adverse effect on the performance of a roof. However, these materials may absorb dangerous quantities of moisture if they are improperly handled or stored. Precautions must be taken during inclement weather to prevent the materials from becoming damp or wet. If the materials are permitted to become damp and are then installed in that condition, it is clear that the moisture will have no means of escape from the roof, since thorough mopping of the roofing felts provides an impermeable barrier to the passage of vapor.

Although the roof deck itself may not be strictly classified with roofing materials, the application of roofing to a wet roof deck is likely to lead to much the same conditions as described above. This is especially true of concrete or similar types of decks where residual moisture may be present even though the surface appears to be reasonably dry. This residual moisture, upon evaporation following the completion of an insulated roof, may enter the roof structure above if a vapor seal course is not used.



Solid Mopping of Roof Decks

CONSTRUCTION PRACTICES

Lack of care on the part of the roofing contractor may cause air and moisture to be trapped within the built-up roof structure. If all plies of the roofing felts are not solidly mopped, areas of poor adhesion will result. In each of these areas a certain amount of air will be present, and since air normally contains some moisture, the stage is set for a pressure rise within the roof structure when it is exposed to a combination of the rays of the sun and a rise in air temperature. The same conditions will exist if the roofing felts are not broomed down immediately following the application of the bitumen, if the bitumen is improperly heated, or if the felts are allowed to crease during application. In short, unless good adhesion is attained between all plies of a roof structure, "pockets" of air and moisture will be present.

VI. THE VALUE OF INSULATION IN BUILT-UP ROOFING

The use of insulation has become increasingly more prevalent during the latter years because of the awakening of the public to the many important purposes it serves. Needless to say, from

an economic standpoint, and with the present high cost of the many types of fuel, the return on the initial investment for installation of insulation is probably greater than that for any other single material in the building industry. Insulation serves to conserve heat during the cold weather and it also serves to reduce the transfer of heat from solar radiation, thereby providing greater comfort within the building during the summer. In certain types of buildings where industrial processes require that high humidity be maintained or where a large amount of moisture is being evaporated into the air to maintain high humidities, insulation serves to prevent condensation on the interior surfaces of the ceilings or walls which could cause inconvenience, disfigurement of ceilings and walls and damage to equipment.

A roof is generally the largest single area of uninterrupted surface of a building and is the location where insulation can be most effective. Many types of structural insulation boards have been developed with specific physical properties for use in the insulation of roof decks. These specific properties are rigidity, strength and maximum insulating value. These materials have also been especially treated to resist absorption of moisture under ordinary atmospheric conditions and to retain this characteristic during and following the construction of a roof. However, as with

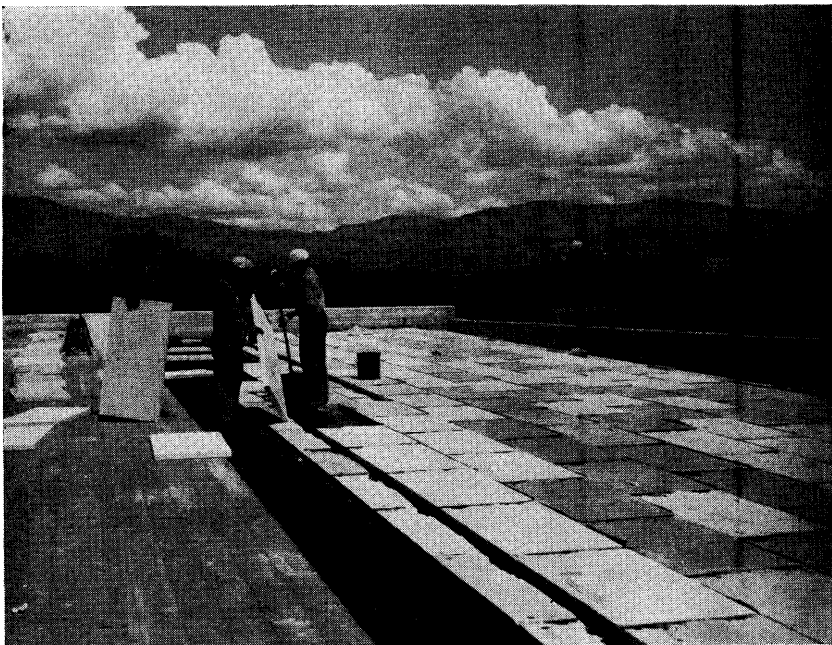

Application of Insulation Board to Roof Decks

all other types of building materials, good judgment must be exercised in handling, storing and the application of insulation board, or any other type of insulation, in order to prevent the insulation from being damp or wet at the time of construction. Likewise, if acceptable design is not followed in the construction of a roof, failure of the roof coverings may occur, together with the loss of the insulating value of the insulation. However, these problems can be overcome by proper field control.

ECONOMIC VALUE

The use of insulation in building construction is based upon sound economic principles and in many cases a full return upon the initial investment may be realized within three to four years. To illustrate this principle, a graphical analysis is shown in Figure 2 to indicate the reduction in heat loss or flow through various types of decks when using different thicknesses of insulation board. Because of the close similarity in heat loss for certain types of uninsulated decks, only two curves are shown. Steel and concrete decks have been classified into one single group, and

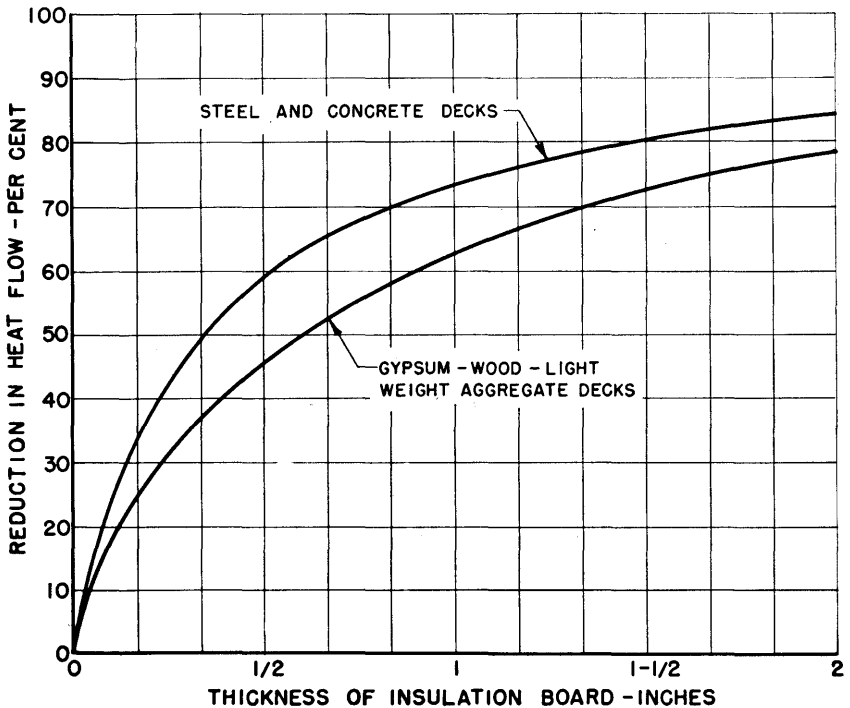

Figure 2. Effect of Insulation Board on Reducing the Heat Flow Through Different Types of Decks

gypsum, wood, and lightweight aggregate decks are classified into another group. From this graph it may be seen that the possible heat saving and reduction in heat loss through a roof deck will vary from 46 per cent with the use of one-half inch of insulation to 84 per cent with the use of two inches of insulation, depending upon the insulation thickness used and the type of deck involved. Obviously, the law of diminishing returns will govern the economical thickness of insulation for each particular job. However, there are other factors which must be taken into consideration, such as assuring an inside surface temperature of the ceiling sufficiently high to avoid condensation. This subject will be discussed later. With regard to the law of diminishing returns, the first inch of insulation will result in a greater saving of heat than will the second inch. The second inch will result in a greater saving than the third inch, etc. This decreasing economic return makes it practical to place a limit on the thickness of an insulating material used.

RESISTANCE TO SOLAR HEAT

The previous discussion on insulation was confined to its value in the saving of heat; however, during the warm months, it serves another important function in offering a high resistance to the passage of heat into a building. As previously discussed, the surface temperature of a roof may reach 150° F to 170° F during periods of direct exposure to the sun's rays. Without insulation, this heat may result in the interior of the building becoming too warm for reasonable comfort.

PREVENTION OF INTERIOR SURFACE CONDENSATION

In serving as a barrier against heat loss, roof insulation serves another extremely important purpose in preventing surface condensation on the interior surfaces of the ceilings. Without this safeguard, cold weather would undoubtedly bring about condensation in buildings maintaining high humidity conditions as a result of industrial processing or ordinary human occupancy where minimum ventilation exists. If adequate provisions are not made to insulate the roof, materials, equipment and furniture may be seriously damaged as a result of water dripping from excessive surface condensation. The effect of insulation in a typical roof deck upon the relative humidity of the inside air that may be maintained without condensation is shown in Figure 3 for an inside air temperature of 70° F and for outside air temperatures

varying from $+20^{\circ}\text{F}$ to -20°F . For example, with an uninsulated roof deck exposed to an outside air temperature of -20°F , the inside air conditions cannot exceed 10 per cent relative humidity at 70°F without surface condensation. Under the same outside air conditions, the application of two inches of insulation will permit the inside relative humidity to be increased to 78 per cent without condensation on the interior surface of the ceiling. Obviously, the outside air temperature has an effect on the maxi-

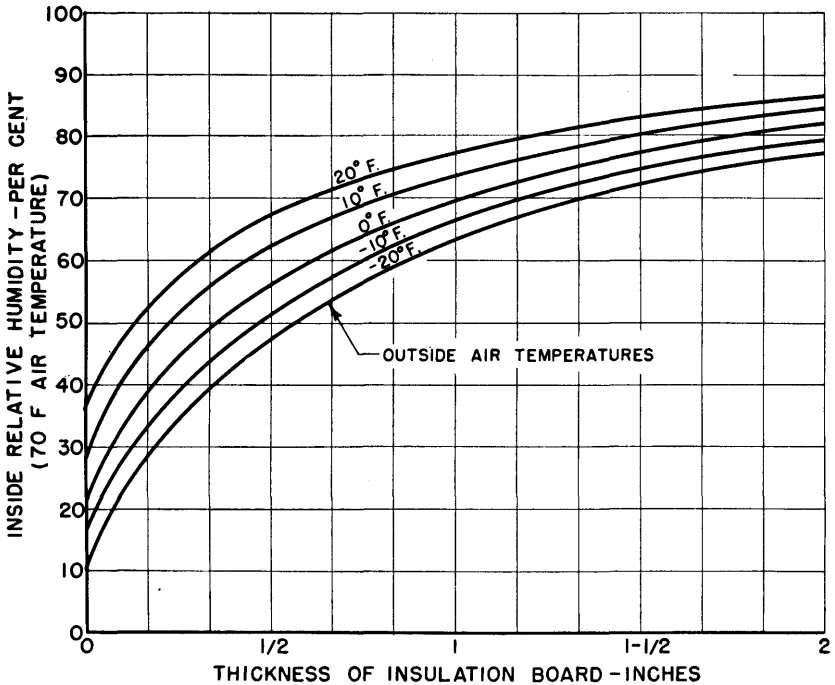

Figure 3. Effect of Insulation Board on the Maximum Relative Humidity That May Be Maintained at 70°F Within a Building Without Surface Condensation

imum humidity which may be maintained within a structure and this is shown within a limited range of temperatures in Figure 4. For example, without insulation in the roof deck the maximum humidity that can be maintained at -20°F is 10 per cent whereas at $+20^{\circ}\text{F}$ it is 36 per cent. With two inches of insulation, however, the variation in humidity is only in the order of 78 per cent for -20°F to approximately 88 per cent for $+20^{\circ}\text{F}$.

The type of deck has a bearing on the heat flow through a section. Steel and concrete decks have approximately the same

resistance to heat flow whereas less heat is transmitted through wood, gypsum and lightweight aggregate decks because of their better insulating qualities. Thus, the quantity of heat which is saved by insulating a wood deck is somewhat less because of its better insulating qualities than that saved by insulating steel and concrete decks. However, as the thickness of insulation is increased to two inches, this variation is reduced approximately by one half, as shown in Figure 4. For all practical purposes it may

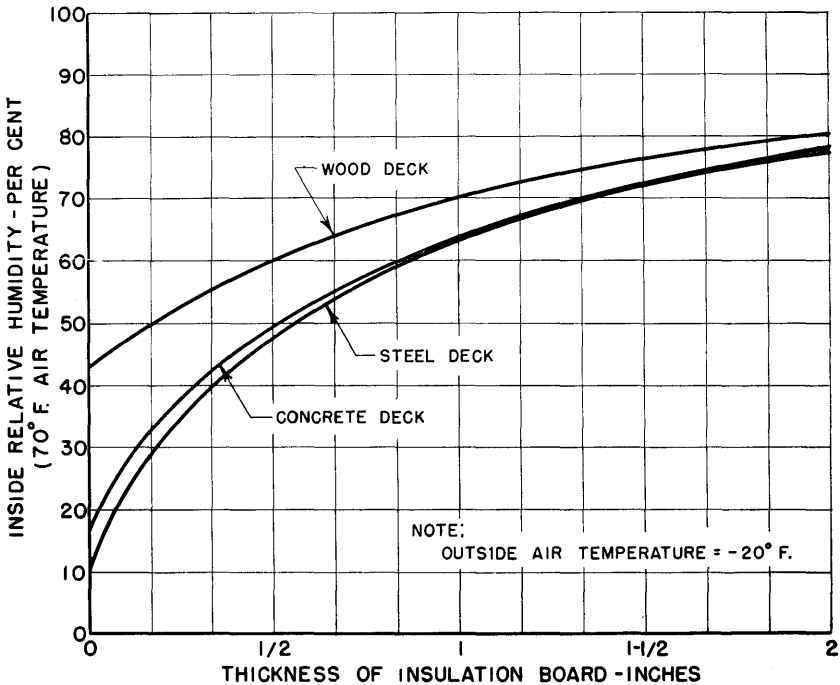

Figure 4. Maximum Inside Relative Humidity Which May Be Maintained at 70° F Without Surface Condensation for Different Types of Decks Constructed with Different Thicknesses of Insulation Board at an Outside Air Temperature of 20° F

be assumed that the amount of heat that is saved through the use of the two inches of insulation is approximately the same for all types of noninsulated decks.

The preceding discussion was concerned primarily with the economic value of insulation. No consideration has as yet been given to the performance of insulation under varying conditions, but this will be discussed later following the presentation of results from the laboratory investigation.

VII. RESEARCH STUDIES ON BUILT-UP ROOFS

During the past five years, extensive laboratory studies of the factors affecting the performance of insulated and noninsulated roofs have been conducted through the cooperation of the Insulation Board Institute and the Engineering Experiment Station at the University of Minnesota. In general, this program was instituted to provide factual information covering the effects of the many variables on the performance of the various components of built-up roof structures. The original program consisted essentially of the following studies:

1. Vapor permeability of typical built-up roofing
2. Vapor permeability of typical vapor seal courses
3. Effect of lapped joints on the vapor permeability of built-up roofing and vapor seal courses
4. Effect of simulated winter, summer, and combined summer and winter weathering conditions on the vapor permeability of roofing
5. Effect of aging on the vapor permeability of vapor seal courses
6. Vapor permeability of vapor seal courses mopped to concrete decks
7. Moisture migration within insulated roofs
8. Field survey of roofing contractors.

The results of these investigations will be briefly summarized in the following discussions. However, the details of these studies may be found in the Appendixes.

TERMINOLOGY

The terms *vapor barrier* and *vapor seal course* refer to materials possessing identical characteristics and may be used interchangeably. However, the term *vapor barrier* is usually used to designate materials having qualities of high vapor resistance applied to the interior surfaces of insulated walls. Whereas the term *vapor seal course* is generally used to designate similar materials installed on the underside of insulated roof structures. The effectiveness of vapor barriers or vapor seal courses is expressed as the quantity of moisture transmitted through the material in grains per square foot per hour per inch of mercury vapor pressure difference across the material. Due to the small quantities of vapor which are transmitted through materials under practical conditions the "grain" has been selected as the unit of weight for the quantity of water vapor being transmitted, 7,000 grains being equivalent to one pound of water.

Vapor pressure is a physical property of water vapor in air, and is expressed either in pounds per square inch or inches of mercury. One pound per square inch is equal to 2.04 inches of mercury. The rate at which vapor will move through a material is partly dependent upon the vapor pressure existing upon the two sides of the material. If a material is subjected to 150° F and 100 per cent relative humidity on the warm side and 0° F and 100 per cent relative humidity on the cold side, the vapor pressure drop across the material would be 7.52 inches of mercury or 3.5 pounds per square inch. This vapor pressure drop is the motivating force for passage of vapor through the material. The amount which will pass through a given material is dependent on both the area and the time involved. Thus it may be seen that different types of materials may be rated for resistance to the passage of vapor in terms of grains per square foot per hour per inch of mercury vapor pressure difference. The criterion for an acceptable vapor barrier is that the vapor permeability does not exceed *one perm* or 1.0 grain per square foot per hour per inch of mercury vapor pressure difference. This limit was established approximately ten years ago after exhaustive research by several investigators.

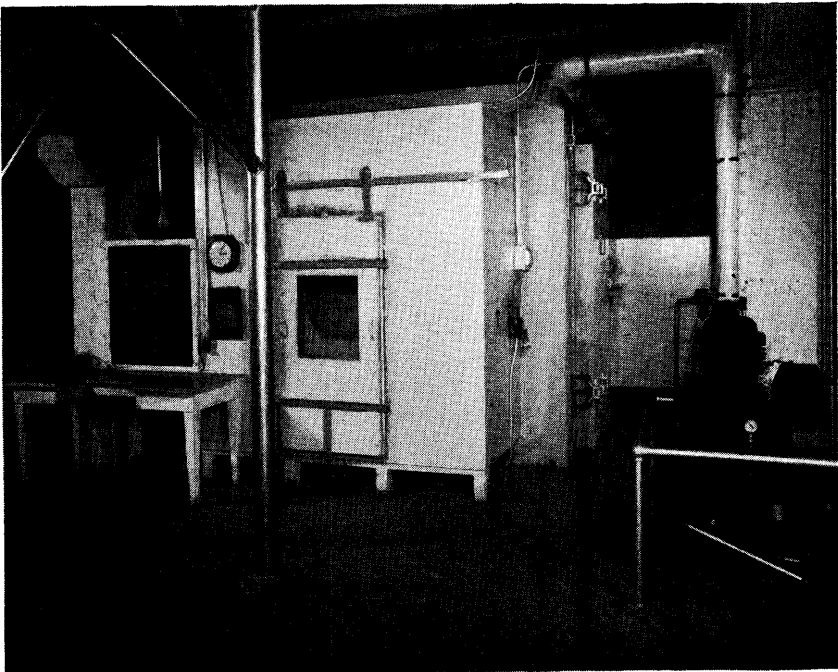

Refrigerated Cold Room Used for Testing Built-up Roofs

TEST APPARATUS¹

In pursuing these studies, it was necessary to develop specific conditions and equipment which would simulate actual field conditions. First, a vapor permeability apparatus was used to determine the vapor permeability of built-up roofing and vapor seal courses. This consisted of a special apparatus in which specimens of the material were usually subjected to a condition of 70° F and 40 per cent relative humidity on the warm side and -10° F on the cold side. For simulating actual field conditions for a complete insulated built-up roof structure, a special apparatus was constructed to hold different types of specimens. The specimens were subjected to 70° F and 60 per cent relative humidity on the warm side and -10° F on the cold side. The same apparatus also provided for the exposure of the specimen to infra-red heat lamps to simulate sun effect during the winter months. Other equipment included summer weathering test apparatus in which simulated summer conditions were reproduced using a combination of infra-red and ultra-violet light together with water spray.

DESCRIPTION OF TESTS AND RESULTS

Vapor Permeability of Typical Built-up Roofs²

Vapor permeability tests were conducted on five typical types of ten-year built-up roofing. Originally, 15- and 20-year types of roofing were also considered. However, these were omitted when it was found that the 10-year types were impermeable to vapor transmission and it was assumed the 15- and 20-year types would be equally as impermeable. The samples were tested in the vapor permeability apparatus at 70° F and 40 per cent relative humidity on the warm side and -10° F on the cold side.

Following 45 days of test all five types of built-up roofing were found to have a zero permeability rate, indicating that they are highly effective as a seal against the transfer of vapor.

Vapor Permeability of Typical Vapor Seal Courses²

Vapor permeability tests identical to those conducted on the built-up roofing were made on four typical types of vapor seal courses. These tests were conducted for a period of 31 days at 70° F and 40 per cent relative humidity on the warm side and -10° F on the cold side.

All four types of vapor seal courses showed a permeability of 0.0 grains per square foot per hour per inch of mercury or that they were impervious to the passage of water vapor.

¹ For details, see Appendix A.

² For details, see Appendix B-3.

Effect of Lapped Joints on the Vapor Permeability of Built-up Roofing and Vapor Seal Courses²

The previous vapor permeability tests were conducted on specimens of both roofing and vapor seal courses having no lapped joints in the test section. Duplicate samples having lapped joints in the test section were tested under conditions identical to those previously described.

The results of these tests indicated that the laps had no effect on the vapor permeability of either the roofing or the vapor seal courses.

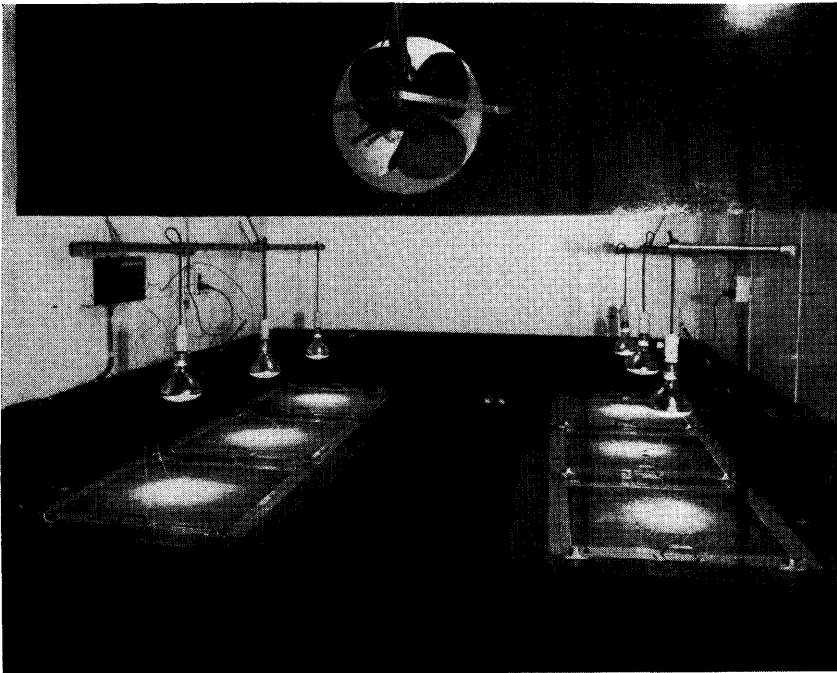

Interior of Cold Room Showing Roof Specimens Exposed to Winter Weathering Conditions

Effect of Simulated Winter Weathering Conditions on the Vapor Permeability of Roofing³

Although few roof failures are known to occur during the winter months, the possibility was considered that if such failures did occur they would not be noted until the following spring or summer. Also considered was the possibility that conditions created within insulated roof structures during exposure to winter

² For details, see Appendix B-3.

³ See Appendix B-4.

weathering might be responsible for subsequent roof failures. To study the effect of winter weathering on roof coverings, an accelerated weathering test was set up to simulate the conditions in the field. Although there may be some question as to the correlation between laboratory tests and actual field conditions, it was felt that the test conditions imposed were severe enough to provide an index of what may be expected.

The tests were set up to include three types of roof structures:

1. Insulated roofs without vapor barriers
2. Insulated roofs with partial vapor barriers to allow leakage of vapor into the insulation
3. Insulated roofs with an impermeable vapor seal course.

The roofing was solidly mopped to the insulation with asphalt applied at the rate of 30 pounds per square. To determine the effect of excess moisture within a roof structure, duplicate panels were prepared with one set containing insulation board having a moisture content of 4.7 per cent, and the second set containing insulation having a moisture content of approximately 18 per cent. A description of the specimens tested is as follows:

Specimen	Vapor Barrier	Vapor Barrier Permeability Gr/sq ft/hr/in.Hg	Moisture Content of Insulation Board Per Cent by Weight
A	None	21.1
B	50-lb surface treated kraft paper	3.93	17.8
C	Vapor seal course	0.00	17.3
D	None	4.7
E	50-lb surface treated kraft paper	3.93	4.7
F	Vapor seal course	0.00	4.7

The specimens were exposed to air conditions on the warm side of 70° F and 60 per cent relative humidity and on the cold side of -10° F for a period of 62 days. In order to simulate sun effect, heat was applied to the roofing surface of the specimens for a period of seven hours daily through infra-red radiation. The roof surface temperature was maintained at 80° F during this period.

The results of the test showed that the 10-year type built-up roofing on all specimens appeared to be in good condition with no evidence of blistering or warping on the surface. Following the test, the roofing was removed from the insulation and tested for vapor permeability. The vapor permeability rates were found to vary from 0.07 to 0.17 perm with an average of 0.10 perm for the six samples. Except as an indication of a trend in increasing permeability due to the accelerated winter weathering tests, the increase in permeability rates is so small that for all practical

purposes the roofing may be regarded as having remained impermeable. Thus, the effects of winter weathering exposure upon roofing appear to be negligible.

Effect of Simulated Summer Weathering Conditions on the Vapor Permeability of Roofing⁴

Due to the apparent occurrence of a great many roof failures during the spring and summer months, it appeared that the heat induced by solar radiation might be a predominating factor in the deterioration of the various components of a roof structure. In order to permit observation of the effect of conditions simulating actual summer weathering on roof specimens of different compositions, three specimens were prepared for test. Each of the specimens was covered with 10-year roofing and differed from the others in vapor seal and insulation moisture content as follows:

1. Vapor seal course and insulation of a low moisture content
2. Vapor seal course with insulation of a high moisture content
3. No vapor seal course with insulation of a low moisture content.

Neither the roofing nor the vapor seal courses were mopped to the insulation on any of the three specimens. The insulation in one of the specimens having a vapor seal course contained 18 per cent moisture and that in the remaining two specimens contained 5.4 per cent moisture. The specimens were subjected to repeated 24-hour cycles of exposure to summer weathering on the roofing side and to room air conditions on the underside. The summer weathering cycle consisted of the following:

1. Fifteen hours of ultra-violet and infra-red radiation to attain a roof surface temperature of approximately 160° F
2. Seven hours of water spray
3. Two hours at room temperature of approximately 75° F.

During the progress of the test, visual inspections showed that small bubbles appeared in the asphalt coating on the built-up roofing during the third day and became larger as the test progressed. The blisters appearing on the specimen having a vapor seal course and insulation containing 18 per cent moisture were larger and occurred in greater numbers than those on the other two samples. After 25 days of test, there was a noticeable pressure formation within this same specimen as was evidenced by bulging of the roofing surface. The vapor permeability rates of the three roof coverings were determined at the end of the 31-day test and found to vary from 0.07 to 0.18 for an average of 0.12

⁴ See Appendix B-5.

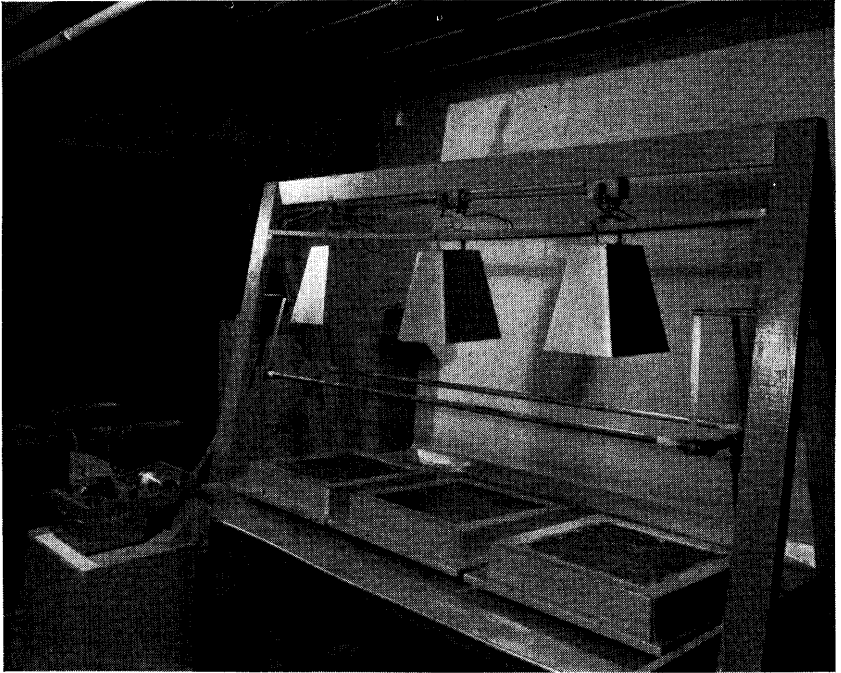

Roof Specimens Exposed to Summer Weathering Conditions

perm. Although there was visual evidence of deterioration of the roofing, the vapor transmission tests showed the permeability of the roofing to be only slightly higher than the roofing subjected to the winter weathering tests. In both cases the permeability rates are extremely low and do not indicate any significant change in the sealing properties of the roofing.

Effect of Combined Simulated Summer and Winter Weathering on the Vapor Permeability of Roofing⁵

The purpose of this test was to determine the combined effect of two types of weathering on the deterioration of insulated roof structures. In order to accelerate the effect of this weathering, the insulation was conditioned to a moisture content of 14 per cent to provide moisture in excess of that normally found within the roof structure.

Two specimens consisting of roofing, insulation and vapor seal courses were exposed to consecutive 30-day periods of summer and winter weathering. As in the previous test, the roofing and vapor seal courses were not mopped to the insulation. The cycle for each was identical to those used in each of the summer and

⁵ See Appendix B-6.

winter weathering tests. However, one specimen, "A," was initially exposed to 30 days of winter weathering, with the other specimen, "B," initially exposed to 30 days of summer weathering. The specimens were then interchanged so as to be exposed to summer and winter weathering of 30 days each, respectively.

During the initial 30-day period of winter weathering for Specimen A, no visible evidence of deterioration occurred. The initial 30-day period of summer weathering for Specimen B produced slight deterioration and pressure rise similar to that which occurred for one of the specimens previously subjected to simulated summer weathering. On the first day following interchange of the specimens, whereby Specimen A was exposed to summer weathering and Specimen B to winter weathering cycles, blisters appeared on the surface of Specimen A and a bulging of the roofing occurred. The blisters were produced during a period of heat application. The height of the bulge above the normal roof surface during this period reached approximately $\frac{1}{2}$ inch. In later stages of the test this bulge subsided to a height of $\frac{3}{8}$ to $\frac{1}{4}$ inch.

The roofing was tested for vapor permeability upon completion of weathering and, as in the previous tests, showed a vapor permeability so small as to indicate negligible change. Thus, it is apparent that exposure of roofing to accelerated weathering conditions does not appear to have any immediate harmful effects upon its sealing qualities.

From the combined results of the weathering tests it is apparent that properly constructed roofing is capable of withstanding extended periods of normal weathering without significant loss in sealing qualities. As stated previously, the period of normal field service represented by the various periods of exposure of the roofing specimens to accelerated weather conditions is not known. These tests were intended merely to furnish an index of what performance might be expected.

Of perhaps greater importance than the apparent effect of the accelerated weathering on the sealing properties of the roofing were the pressure characteristics exhibited by the various specimens. The specimens which had a vapor seal course and which contained insulation having an abnormally high moisture content all showed visible signs of pressure increase during exposure to summer weathering conditions. This was an expected result, and had the roofing been mopped to the insulation, the pressures developed would not have been sufficient to bulge the roofing. However, the specimen which was first subjected to winter weathering conditions and, following that exposure, subjected to summer weathering conditions showed by far the greatest initial pressure rise. This occurred due to the fact that during the period of cold exposure the moisture within the insulation concentrated next to

the underside of the roofing. This phenomenon, known as "moisture migration," will be discussed in detail later. Upon application of the simulated summer heat this concentration of moisture could not redistribute itself in a short enough time to avoid a rather severe initial pressure build-up. The behavior of this specimen furnishes a logical explanation for the prevalence of structural blistering during the spring and early summer months. The concentration of moisture adjacent to the underside of the roofing, in addition to providing a source for sudden pressure build-up, may also reduce the bond strength between the roofing and the deck surface, thus providing a greater opportunity for blistering.

Effect of Aging on the Vapor Permeability of Vapor Seal Courses⁶

Vapor permeability tests were conducted on the vapor seal courses used in the weathering tests. The results of these tests showed vapor permeability rates varying from 0.18 to 0.35 perm and indicated that no definite increase of any magnitude had occurred for any of the specimens. The vapor seal courses used on the combined summer and winter weathering tests indicated a slightly greater permeability than did the vapor seal courses subjected singly to either winter or summer conditions. It is problematical whether this is an indication of a trend toward increasing permeability of a vapor seal course because of aging, as only a limited number of tests were conducted. In any event, the increase in permeability brought about by these aging tests is small and insignificant.

Effect of Concrete Decks on the Permeability of Vapor Seal Courses⁷

To establish whether or not a vapor seal course applied to concrete decks suffers any decrease in its sealing efficiency, a special study was made of a concrete slab. It was felt that a partial absorption of the primer or undercoat by the concrete, together with the partial absorption of the top surface coat of the vapor seal course by the roof insulation, might decrease the effectiveness of the vapor seal course. The vapor seal course consisted of mopping the concrete with hot asphalt primer at the rate of one gallon per square followed by one layer of 15-pound asphalt felt solidly mopped with 30 pounds of asphalt per square. A ½-inch layer of insulating board was imbedded in the hot surface mopping of the vapor seal course. The results of these tests indicated that this method of construction had little or no effect upon the vapor permeability of the vapor seal course.

⁶ See Appendix B-7.

⁷ See Appendix B-8.

Moisture Migration Within Insulated Roofs⁸

Moisture may enter the roof structure through the roof covering, or it may be sealed into the roof structure at the time of construction. Moisture may also enter in the form of water vapor from the warm side, due to the lack of proper vapor seal, or because of the inefficiency of the vapor seal course. To reproduce these conditions, specimens containing different types of vapor seal courses having varied rates of vapor permeability were studied. In addition, a study was made on the effect of insulation of high moisture content when sealed into a roof structure at the time of application.

The initial investigation consisted of a study of the effect of water vapor entering a roof structure having dry insulation containing 1.9 per cent moisture and an effort to determine how different quantities of vapor leakage affect the moisture distribution within insulated roofs. In order to cover a wide range of vapor leakage through the warm side, one specimen had no vapor barrier with five having vapor barriers of different rates of vapor permeability to provide varying degrees of leakage. These barriers had a vapor permeability rate varying from 0.0 (vapor seal course) to 14.35 grains/sq ft/hr/in.Hg (a poor vapor barrier). The tests were continued for 49 days with the air on the warm side at 70° F and 60 per cent relative humidity and the air on the cold side at -10° F.

A visual examination of the specimens at the end of 49 days showed the following conditions:

1. Specimen A—*No vapor barrier on the warm side.* The built-up roofing was very brittle and was frozen solidly to the insulation. Ice approximately 1/16 inch thick was found between the first and second laminations of the insulating board on the cold side.
2. Specimen B—*A partial vapor barrier on the warm side consisting of 70-pound surface-treated kraft paper having a vapor permeability rate of 3.22 grains.* A film of frost was found underneath the roofing, but the insulation appeared dry and no frost accumulation was found between the laminations.
3. Specimen C—*A partial vapor barrier on the warm side consisting of 50-pound surface-treated kraft paper, having a vapor permeability rate of 3.93 grains.* A heavy accumulation of frost and ice occurred beneath the roofing felt. The ice crystals had formed in shapes ½ inch in diameter and 1/16 to 3/32 inch in thickness at approximately thirty points over the surface.

⁸ See Appendix B-9.

4. Specimen D—*A partial vapor barrier on the warm side consisting of No. 15 asphalt-saturated felt having a vapor permeability rate of 2.60 grains. Only a slight amount of frost was visible on the under side of the roofing and the insulation appeared to be dry throughout.*
5. Specimen E—*A poor vapor barrier on the warm side consisting of red rosin paper having a permeability rate of 14.35 grains. The built-up roofing was frozen to the surface of the insulating board with an ice and frost accumulation of approximately 1/32 to 1/16 inch thickness uniformly distributed over the entire surface of the underside of the roofing. Frost was also found between the first and second layers of the insulating board on the cold side.*
6. Specimen F—*A good vapor barrier consisting of a vapor seal course having a permeability rate of 0.0 grains. No frost was evident either on the underside of the roofing or within the insulation. The insulation appeared dry throughout.*

A second investigation was conducted to determine the effect of insulation having a high moisture content. To make this study, six panels were constructed: three having insulation of a moisture content varying between 17 and 21 per cent, and three with a normal moisture content of approximately 4.7 per cent. In addition, each set of three specimens consisted of one having a vapor-seal course of high resistance to vapor transmission, the second having a partial vapor seal permitting a small amount of vapor to enter into the insulation from the warm side, and a third with no vapor seal course on the warm side. Air conditions on the warm side of the specimens were maintained constant during the 62-day test period at 70° F and 60 per cent relative humidity. The air on the cold side was maintained at -10° F. Following the conclusion of the 62-day test period, a visual examination of the six panels was made. The results of this examination are as follows:

1. Specimen A—*No vapor barrier with insulation containing 21.1 per cent initial moisture. The first three layers of the ½-inch insulating board on the cold side of the specimen were solidly frozen together and could not be separated until the frost and ice contained in the board had melted. The remaining layer of board, which was exposed to the warm air, was found to be damp.*
2. Specimen B—*A partial vapor barrier consisting of 50-pound surface-treated kraft paper having a vapor permeability rate of 3.93 grains and insulation containing 17.8 per cent initial moisture. The cold side layer was very wet, and frost was found between this layer and adjacent layer. The two warm side layers were damp.*

3. Specimen C—*A roofing vapor seal course having a vapor permeability rate of 0.0 grains and insulation having 17.3 per cent initial moisture.* The cold side layer of insulation was damp and frost had accumulated adjacent to the underside of the roofing. The remaining three layers of insulation all appeared to be dry.
4. Specimen D—*No vapor barrier and insulation having 4.7 per cent initial moisture.* Frost was found between the first and second and between the second and third layers on the cold side. The insulating board in each of the layers was wet. The fourth layer of insulating board was damp on the cold side surface, but it appeared to be dry on the warm side.
5. Specimen E—*A partial vapor barrier consisting of 50-pound surface-treated kraft paper having a vapor permeability rate of 3.93 grains and insulation having 4.7 per cent initial moisture.* The cold side layer was wet on the surface adjacent to the roofing, with the remaining three layers being dry.
6. Specimen F—*A roofing vapor seal course of low permeability and insulation having 4.7 per cent initial moisture.* In this case, the insulation was completely dry throughout the specimen.

Following the visual examination of the insulation in both investigations, a quantitative analysis of the moisture migration and redistribution within the insulation confirmed the visual examinations. Referring to Figure 5, the moisture distribution is shown through two inches of insulation from the warm to the cold side. This figure also illustrates the effect of vapor seal courses versus no vapor seal and the effect of insulation of high and low moisture content at the time of installation. Where no vapor barrier was included in the specimen, the insulation of low moisture approaches a final moisture content equivalent to that of the insulation having a high moisture content at the time of installation. This shows the effect of water vapor accumulation within insulation when not protected by a vapor seal course. The final moisture content in the insulation on the cold side increased from 21 per cent to 102 per cent and from 5.0 per cent to 86 per cent for the two different conditions. The average moisture content of the two inches of insulation in each case increased from 21 per cent to 75 per cent and 5 per cent to 65 per cent, respectively. Where a good vapor seal course was included, a redistribution of moisture occurred from the warm to the cold side, the warm side of the insulation drying out and the cold side becoming correspondingly more moist. For the case of insulation of high moisture content sealed into the specimen, the insulation on the warm side decreased in moisture content from 18 per cent to

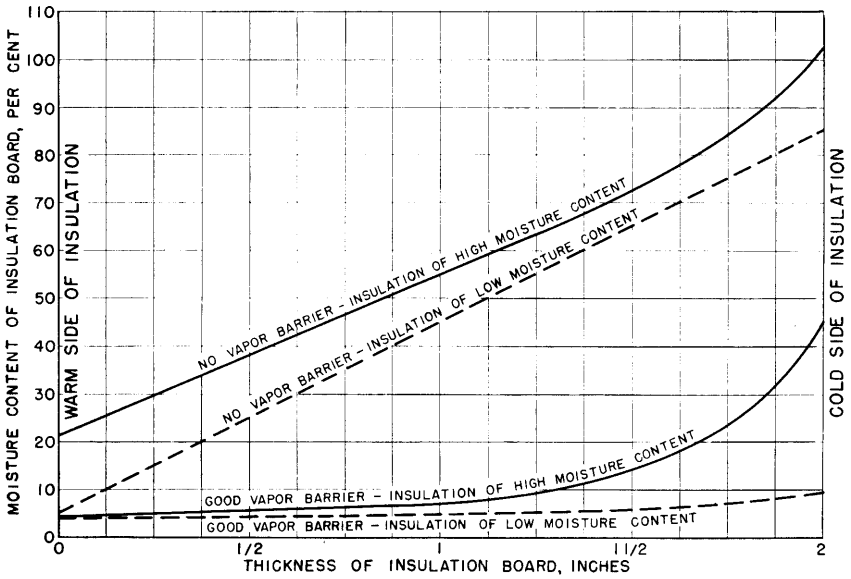

Figure 5. Effect of Vapor Barrier on Moisture Redistribution Within Roofs

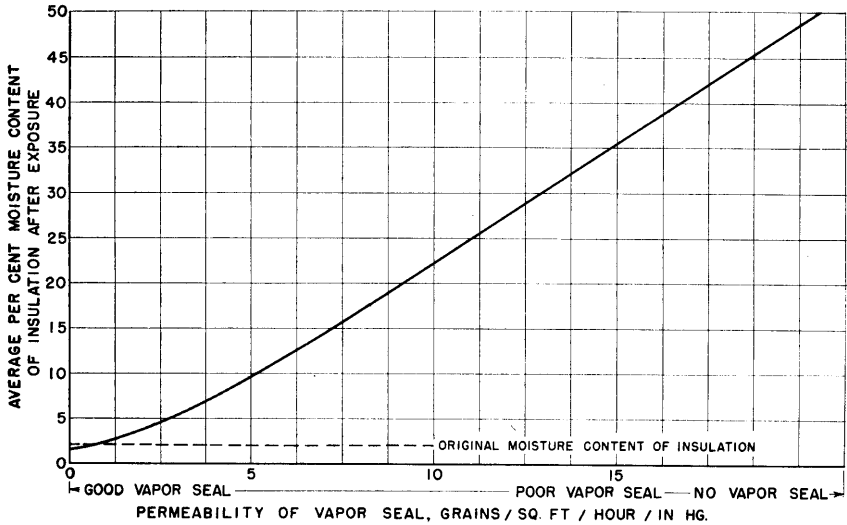
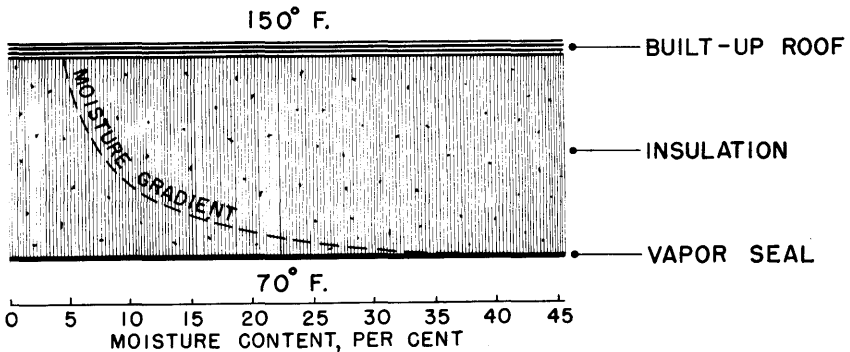
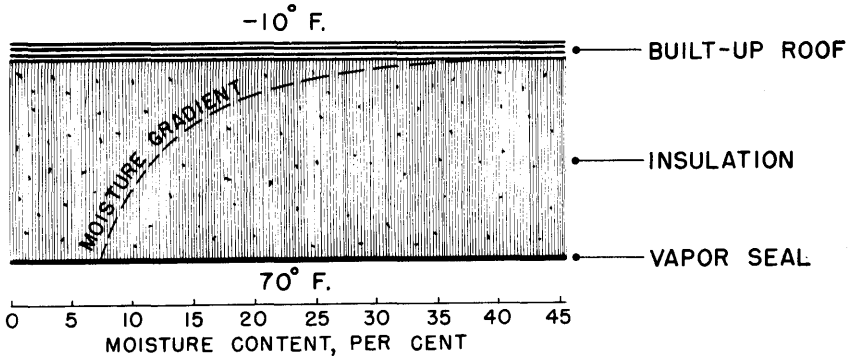

Figure 6. Effect of Vapor Barriers of Different Permeabilities on Moisture Accumulation Within Insulation

6 per cent and increased on the cold side from 18 per cent to 46 per cent. For insulation of low moisture content sealed into the specimen, the corresponding change was from 6 per cent to 4 per cent on the warm side and 6 per cent to 10 per cent on the cold side. The average moisture content of the two inches of insulation in both cases did not change, indicating that no water vapor entered the specimen from the warm side because of the effectiveness of the vapor seal course.

Further indication of the effect of water vapor leakage due to inferior or partial vapor seal courses on the warm side is shown in Figure 6. The average original moisture content of the insulation at the time of installation in each case was 1.9 per cent. As shown in Figure 6, the rate of water vapor entering the insulation is approximately directly proportional to the effectiveness of the



Effect of Roof Surface Temperature on Moisture Gradient Within Insulated Roof Decks

vapor seal courses. For a good vapor seal, no change in moisture content of the insulation occurred during the 62-day period of maximum exposure (70° F and 60 per cent relative humidity on the warm side and -10° F on the cold side). However, for vapor barriers having progressively poorer sealing qualities, the moisture content of the insulation progressively increased until it attained a value of 39 per cent for a poor barrier and 41 per cent where the barrier was omitted. Obviously, if the test had been continued for a longer period, a further increase in moisture could have been expected in the insulation where inadequate vapor barriers were used.

These tests indicate conclusively what may be expected when a vapor seal course is not used, or when a partial vapor seal course is used which will permit vapor to enter the insulation. They also show clearly the result of installing insulation of a high moisture content, even though a vapor seal course is used. Under these conditions the moisture may be sealed within the roof structure and there is a redistribution of moisture to the cold side.

The preceding analysis dealt primarily with the condition where the roof temperature was lower than that of the underside of the roof deck. Where summer conditions prevail with higher temperatures on the roof due to rise in air temperature and solar radiation, the moisture gradient will be reversed. The redistribution of moisture will cause a higher concentration of moisture in the insulation adjacent to the roof deck.

CONCLUSIONS

The results of the research studies have provided the following conclusions which are of prime importance in the study of factors affecting the life of built-up roof structures:

1. Typical ten-year built-up roofing is impermeable to water vapor transmission or provides an effective seal against vapor. Fifteen- and twenty-year types may be assumed to be equally as impermeable.
2. Typical vapor seal courses of two-ply felt solidly mopped or similar applications are effective seals against vapor transmission.
3. Lapped joints when properly constructed provide an excellent seal in either the built-up roofing or in the vapor seal courses.
4. Simulated weathering exposure did not have any appreciable effect upon the vapor sealing qualities of either the built-up roofing or vapor seal courses. For all practical purposes, the effect of such exposure was negligible.

5. Solid mopping of a two-ply vapor seal course to a concrete deck followed by the application of insulation board had no effect upon the vapor sealing qualities of the vapor seal course.
6. An approved type of vapor seal course consisting of two plies solidly mopped felt or equal construction is necessary to prevent moisture from entering insulated roofs. Partial vapor barriers are not recommended.
7. Moisture, caused by atmospheric conditions or insulation having a high moisture content, may be sealed within a roof structure and may be redistributed and concentrated in areas of the roof depending upon temperature conditions. Such concentration may cause excessive moisture conditions in certain parts of the insulation with resultant decrease in insulation efficiency or bonding of the roofing plies and subsequent blistering of the roofing felt.

FIELD SURVEY OF ROOFING CONTRACTORS

During 1951, a general survey of roofing contractors was conducted for the purpose of expanding and substantiating the information obtained from laboratory studies as well as to obtain information as to the seriousness of roof failures in the field.

The survey consisted of personal interviews with 32 roofing contractors in cities located in three widely separated areas. These areas consisted of the following:

1. Upper Midwest: St. Paul and Minneapolis, Minnesota
2. Midwestern: Rockford, Illinois; St. Louis, Missouri; Des Moines, Iowa
3. Eastern: Washington, D.C.; Baltimore, Maryland; Philadelphia, Pennsylvania

A summary of results which lend themselves to tabulation are shown in Table II. There are some differences of opinion, the most outstanding being the divergence as to the advisability of using a vapor seal course. As may be expected, contractors in the Upper Midwest are more in favor of the use of vapor seal courses than those in the other two areas. Additional expense is a primary factor governing the opposition to the use of vapor barriers. This divergence in opinion reflects the climatic differences in the three areas, with the Upper Midwest, of course, having the lowest mean temperature of the three areas surveyed. The roofers are in general agreement that wherever a vapor barrier is used, it should consist of two plies of 15-pound felt solidly mopped.

The majority of the contractors favor the practice of solidly mopping all felts to the roof deck, with 100 per cent also in favor of solidly mopping the insulation. In regard to the use of temporary roofs, there is unanimous agreement that temporary roofs should not be used as they tend to promote blisters and may cause moisture to be sealed into the roof structure. The added expense is also an objection. With respect to the types of roof decks now being constructed, metal and concrete are equally popular, with a general decline in the use of the wood deck. Approximately 82 per cent of all roof decks are insulated.

Contractors agree unanimously that blistering occurs on only a small percentage of the total number of roofs constructed. When questioned as to whether these failures could be associated with any particular structural component of the roof, that is, type of roof deck and presence or absence of insulation, the majority feel that there is no relation.

Of the remainder, the largest number stated that roof blisters most commonly occur on concrete decks, and this opinion is substantiated by the fact that concrete decks are frequently roofed while still containing a large quantity of moisture. Also, uninsulated concrete decks often present an irregular surface for the roof application which is conducive to the formation of air pockets due to the difficulty of brooming the felts over a rough surface. There is general agreement that roof blisters contained air or water, and that the majority of the blisters occurred between the roofing felts.

Roof Decks

The general practice in treating the various roof decks prior to the application of the insulation and the felts is as follows:

1. **Wood Decks:** The application of red rosin paper followed by two plies of felt nailed to the deck. This is followed by a solid coating of bitumen mopped to the surface. This preliminary treatment has been found necessary to seal up the cracks to prevent dripping through the roof when applying the built-up roof.
2. **Metal Decks:** A solid coating of asphalt felt is mopped directly to the steel deck where the joints are of such construction that the asphalt will not flow through. Wherever joints are large, and to avoid dripping, two plies of asphalt felt are applied to the steel deck followed by a solid mopping of asphalt.
3. **Poured Concrete Decks:** The contractors emphasize the fact that, in general, concrete decks are giving them the most trouble in so far as blistering is concerned. The reason is, of

course, that there is an excessive quantity of moisture remaining within the concrete at the time of roof application. Concrete decks are difficult to dry because of the initial moisture content and also because of possibility of exposure in inclement weather. Because of this fact, the general practice is to apply a seal coat directly to the deck prior to laying of the roof in order to avoid moisture migration into the materials above. However, this does not conform to a vapor seal course and should not be construed to be an effective vapor seal. An added factor in this problem is that all roofs are applied upon the request of the general contractor who exerts considerable influence to have the roof applied as quickly as possible. A concrete deck is usually considered sufficiently dry for application when pitch or asphalt will adhere to the surface. In some cases where the concrete is excessively damp due to an inadequate drying period, a floating vapor barrier is applied directly to the deck. This consists of two layers of asphalt felt laid directly over the concrete, followed by a solid mopping of asphalt.

Vapor Seal Courses

The survey reveals that some form of a vapor seal is generally used in roof construction, although not always called by that name. Thus the matter is largely one of defining what does or does not constitute a vapor seal course. As was mentioned previously, roofing contractors usually apply some type of a sealer prior to the application of the insulation or the roofing felts. This sealer is applied to metal decks and to uncured concrete decks. The latter especially has been forced upon the contractor because of his past experience. Thus, it is apparent that a *vapor seal course in some form is being used in most cases* in insulated built-up roofs regardless of the type of deck involved. Although a seal coat is not as effective as a vapor seal course applied according to specifications, this practice does provide a partial barrier which reduces the moisture migration into the roof structure. The degree of its effectiveness is largely dependent upon the quality of workmanship and control practiced by the roofing contractor. In general, when discussing vapor seal courses, the roofing contractor immediately connected this with the special application of a vapor seal course consisting of solidly mopping two layers of 15-pound felts to the deck. A vapor seal course in most cases was applied only upon the specific request of the architect or customer. On the other hand, most contractors have been installing some sort of vapor barrier to the deck, regardless of whether or not it has been specified. Since the roofing contractor considers

it good practice to apply a seal coat to the different types of decks prior to the application of the insulation and built-up roofing, special precautions exercised during this operation to obtain a uniform seal against vapor entrance would result in a satisfactory partial vapor barrier with only a slight increase in the cost of application.

Many contractors feel that the use of vapor barriers is advisable where high humidity conditions exist. Due to the practice of sealing the deck, it is evident that the possibilities of moisture migrating from the structure into the roof deck have been greatly reduced. On the other hand, if this practice had not been in existence, there might have been a greater percentage of roof failures due to blistering. The general practice of sealing the roof deck is a contributing factor in reducing the blistering of roofs, and as indicated by the survey, such failures are less than 5 per cent.

Roof Insulation

In general, the majority of the roofing contractors favor the use of some type of insulation board, not only from an economic heat saving or heat resisting standpoint, but from the standpoint of roof application. They feel that better quality roofs can be obtained by the application of the felts to an insulation board surface. Due to the smoothness of surface, the plies of roofing felts can be more easily broomed down with better adhesion between the various layers of felt. This reduces the possibility of air or moisture being trapped between the plies. As shown in Table II, the majority of contractors prefer the butt type of insulation board joint, as it simplifies the method of cutting the board and thereby reduces the cost of installation. The physical properties which they prefer, and would like to find in insulation board to be used in roof construction, are as follows: rigidity, resistance to normal loading and traffic during construction, ease of handling, ease of fabrication, and high resistance to moisture.

In so far as insulating concrete is concerned, the main objection to this type of deck is that it is difficult to dry the concrete within a reasonable length of time, which necessitates the application of the built-up roof before the deck is completely dry. In such cases the moisture is sealed into the concrete and will eventually find its way into the plies of the felt and cause blistering. Again, some of this objection has been overcome by applying a floating vapor barrier course consisting of asphalt felts laid directly upon the concrete followed by the mopping of a solid coating of asphalt. In some cases this has caused heaving of the roofs due to the excessive amount of moisture within the concrete, particularly if the concrete has no means of venting on the underside. The summary shows that most roof decks are insulated.

TABLE II
Summary of Results of Roofing Contractor Survey for Upper Midwest,
Midwestern, and Eastern Areas

	Upper Midwest Area	Midwestern Area	Eastern Area
CONTRACTORS SURVEYED	6	12	14
ROOF APPLICATION DATA			
Type of Deck:			
a. Concrete, per cent	30	32	44
b. Wood, per cent	25	21	16
c. Metal, per cent	45	57	40
Insulation:			
a. Roofs, insulated, per cent	80	78	87
b. Joint preferred	butt	butt	butt
Vapor Barrier:			
a. Favor general use, per cent	83	42	44
b. Favor use in special cases only, per cent.....		24	6
c. Opposed to use in any case, per cent	17	34	50
d. Per cent of (a) and (b) recommending use of 2 plies 15-pound felt, solidly mopped.....	100	100	100
General:			
a. Solid mop vapor barrier, per cent	100	83	93
b. Solid mop insulation, per cent	100	100	100
c. Solid mop roof felts, per cent	100	83	100
d. Oppose use of temporary roof, per cent	100	100	100
ROOF FAILURE DATA			
Per cent Due to Blistering Failures (less than):.....	5	5	5
Blistering Failures Commonly Associated with:			
a. Concrete roof decks, per cent	0	17	57
b. Wood roof decks, per cent	0	0	0
c. Metal roof decks, per cent	0	0	0
d. Use or absence of insulation, per cent	0	0	0
e. Use or absence of vapor barrier, per cent	0	0	0
f. None of the above, per cent	100	83	13
Blisters Usually Contain:			
a. Air only, per cent	50	8	50
b. Air and water, per cent	50	75	36
Blisters Are Usually Located:			
a. Between felts	65	100	53
b. Between felt and insulation	35	0	47

Application of Roofing Felt

The general consensus of opinion regarding the use of different types of materials is that pitch and gravel roofs should be used on roofs where the slope is $\frac{1}{2}$ inch or less per foot. In some cases this may be increased to 1 inch per foot but never should exceed 2 inches per foot. On any steeper slope, asphalt should be used.

Under no circumstances are asphalt products to be mixed with pitch or tar products, that is, asphalt and asphalt felts should be used exclusively and pitch and tar felts exclusively, unless each is separated by the insulation similar to that which occurs over metal decks.

The majority favor the use of perforated felts in construction of asphalt roofs as they believe that perforated felts increased the bond between the successive layers of felt by allowing the

asphalt to penetrate through the perforations. The use of perforated felts has been found helpful in the prevention of blistering because it creates a more positive bond and thus eliminates air pockets. The majority of contractors interviewed are agreed that vapor barriers, insulation and roofing felts are to be solidly mopped to the roof deck to obtain the optimum results. Spot or strip mopping of the roofing did not meet with their general approval as it is felt that this would cause air to be trapped between the plies and result in blistering.

An interesting opinion noted during the survey was that blisters are less common in a pitch and gravel roof. The reason given was that the weight of the gravel imposes a uniform weight over the felts and induces a seal between the felts due to the softening of the pitch when exposed to high temperatures. A reason of equal or perhaps greater importance is that the lighter color presented by the graveled surface reduces the heat gain from solar radiation. If a positive seal is not obtained at the time of application, the effect of the heat of the sun combined with the weight of the gravel causes a softening of the pitch and subsequent sealing of the plies. This confirms the necessity of solid mopping and positive adhesion between roofing plies.

No one advocates the use of temporary roofs as this practice increases the cost and also creates a considerable amount of difficulty in servicing the permanent roof applied later.

Blistering of Roofs

The majority of contractors agree that uncured concrete decks and wood decks applied with green lumber are contributory causes of blistering. If such decks are covered with felt and followed with a solid mopping of asphalt prior to the installation of the insulation and the built-up roofing, the blistering problem will be reduced to a minimum. It is also the consensus of opinion that blisters contain water, water vapor or air. The repairing of these blisters is usually accomplished by opening up the blister and thoroughly cleaning out the damaged section and then resealing with additional felt and pitch or asphalt. The survey revealed that individual opinions expressed by roofing contractors as to the causes of roof blisters and failures were nearly all contributory causes as deduced by laboratory investigation. These were:

1. Layers of felt not solidly mopped, thereby causing air to be trapped between the layers of felt
2. Not thoroughly brooming down the roofing felts
3. Improper heating of the pitch or asphalt
4. Intermixing of asphalt and pitch products whereby poor adhesion is obtained

5. Workmanship
6. Not following accepted approved specifications
7. The application of roofing felt having too high a moisture content
8. The application of a roof during inclement weather or upon a deck which is not thoroughly dry
9. Improper protection and storage of materials on the site during construction.

VIII. CAUSES AND PREVENTION OF ROOF FAILURES

Thus far, the emphasis has been placed on analysis and investigation of the problems inherent in built-up roof construction, and the extent to which these factors influence the performance of built-up roofs. To substantiate the analysis, and to assist in solving the problems, both laboratory and field studies have been included. The following summary is mainly concerned with the prevention of roof failures and the ways in which certain factors are detrimental to the life of a built-up roof.



Solid Mopping of Roofing Felts

Considerable emphasis has been placed upon solid mopping of the roofing plies to obtain a positive adhesion between the plies. Poor or incomplete adhesion may also result from lack of brooming down of the felts, creasing of the felts during application, the practice of strip or spot mopping, the use of materials having high moisture content, delay in application and brooming down of felts following the application of the hot bitumen, or application of bitumen at improper temperatures.

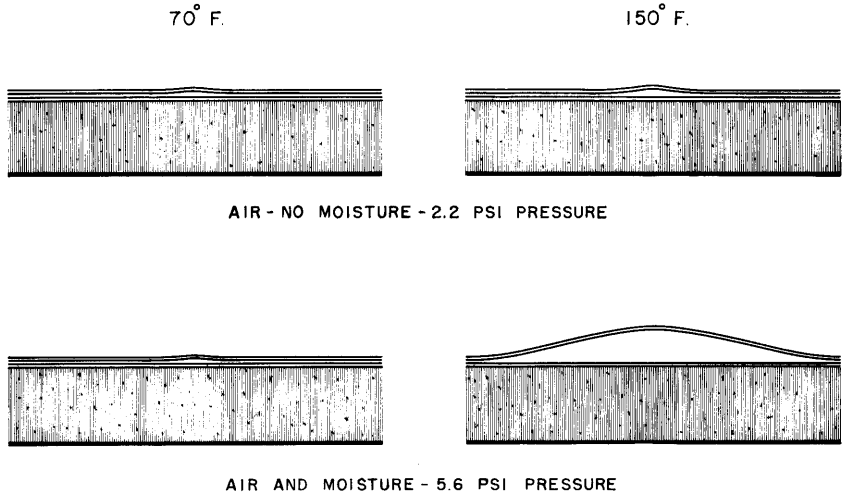

Pressures Developed Within Roofing Plies as Affected by Heat, Air and Moisture

Where good adhesion between plies is not attained, a certain quantity of air and vapor will be confined between the plies. Upon a rise in air temperature and exposure to solar heat, the temperature of the roof may be increased by 80°. This rise in air temperature produces a corresponding increase in pressure where the air and moisture are "trapped." Considering air alone, the pressure increase is 2.2 pounds per square inch, or 317 pounds per square foot for an air temperature rise from 70° F to 150° F, providing no expansion takes place. If expansion takes place at constant pressure, the volume increase will be 15 per cent. Of greater significance are the conditions created where small quantities of free moisture or water are concerned. If a small quantity of moisture were trapped within the roof plies and exposed to the same temperature increase of 80° F, the vapor pressure rise is approximately 3.4 pounds per square inch, or 490 pounds per square foot, due to the vaporized water alone. If the pressure remains constant due to the expansion of the roofing plies, this vapor will also add to the volumetric expansion. It is apparent

that the effect of the water vapor is of considerable importance in addition to the effect of dry air.

How are blisters created by the sealing of air and free moisture between roofing plies? The weight of a 4-ply pitch and gravel roof is approximately 620 pounds per square (100 sq ft), or 6.2 pounds per square foot, or 0.04 pound per square inch. Tests have shown that the tensile strength of the bond between solidly mopped plies of felt is over 14 pounds per square inch. The strength of the bond between roofing plies and insulation is approximately 10 pounds per square inch. Thus, the pressures developed by air pockets alone are sufficient to raise the weight of a 4-ply roof, but not sufficient to cause separation of the roofing plies in direct tension. However, at this point, the bond between the roofing and the insulation must be given special consideration. Where moisture has been present within insulated roofs, the redistribution of this moisture results in an accumulation of frost—depending upon the temperature—at the juncture of the roofing and the insulation. Upon a rise in temperature, the frost melts and the insulation becomes wet, with a resultant reduction in the bond strength between the insulation and the roofing felts. The existing pressure can then easily raise the roofing in blisters which are usually large in area and low in elevation. This type of blister is not readily seen, and is usually detected because of the characteristic “spongy feeling” which it gives to the roof surface.

Regarding the separation of the roofing plies or the separation of the roofing from insulation of a normal moisture content, another factor must be considered, that is, the shearing force developed in separating the materials. It has been previously shown that the tensile strength between the plies themselves and between the insulation and roofing (where solid mopping is practiced) is considerably greater than the pressures which may be developed. However, where there is incomplete adhesion, the trapped air or moisture tends to separate the plies along the line of adhesion by a shearing action as well as by direct pressure.

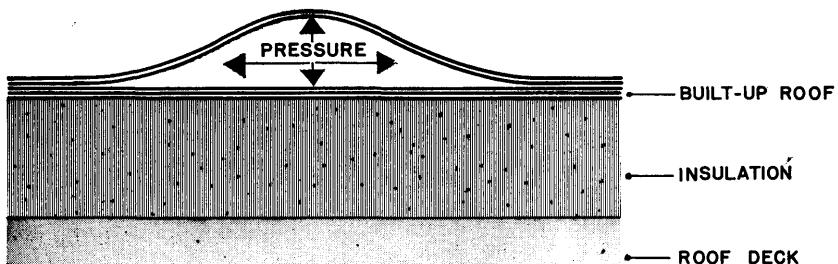

Shearing Action Developed Due to Pressures Between Roofing Plies

The shearing action is exerted in a bellows effect, and causes a gradual reduction of strength of the bond surrounding the pocket. Thus, blistering may result from pressures much lower than 14 pounds per square inch, and may not become apparent for months after the application of the roof. Once a separation of the plies has started, a progressive action takes place which causes elongation or stretching of the felt in order to equalize the pressure. This elongation or stretching may eventually produce alligator ridges sufficiently sharp to cause erosion of the top surface mopping, or may exceed the elastic limit of the felts and cause ruptures. Under these conditions it is apparent that leaks will appear which will increase the difficulties mentioned. Leaks which do occur frequently do not appear directly above the point where the pressures were originally developed. Job inspections have shown that pressures may be channeled from 8 to 10 feet from the trouble source to the point of rupture. Also, condensed moisture has frequently been found within unbroken blisters.

The use of an approved type of vapor seal course is of utmost importance in built-up roofs. There are several types which may be used, and laboratory tests have shown that a two-ply, solidly mopped, 15-pound felt will prevent vapor from entering the roof structure from the warm side. Similar vapor seal courses are also efficient. Concrete decks, regardless of the location or use of the building, require a vapor seal to prevent the moisture which results from the drying of the concrete from seeking an escape into the insulation or the roofing plies. Where abnormally high humidities are anticipated within a building, it is imperative that a vapor seal be used, regardless of prevailing outside temperatures. In areas of low outside temperatures, a vapor seal is necessary even if inside temperature and humidity conditions are favorable.

In some cases, vapor seal courses have been omitted in the construction of insulated roofs, with the omission causing no apparent difficulty. This has been possible because of existing practices which unintentionally provide a partial vapor protection for the insulation. Insulation applied directly to a concrete deck is usually mopped solidly to the concrete surface. This mopping provides a resistance to the passage of moisture from the concrete to the insulation, but does not provide a complete vapor seal. A similar procedure is used in the application of roof insulation to wood or metal decks, with some modification to prevent the bitumen from dripping through cracks into the space below.

For all three types of decks (concrete, wood, or metal) the deck material itself constitutes a reasonably good vapor barrier; in the case of metal, a perfect vapor barrier. For these decks,

the primary passage for water vapor is through cracks. Since this passage is partially blocked by a layer of felt and bitumen mopping, large amounts of moisture are prevented from entering the insulation. Although apparent difficulties may not be encountered through use of the construction methods described above, even where conditions of low outside temperatures and high inside humidities exist, such practices are not recommended as a substitute for an approved vapor seal course. The expansion and contraction of the roof deck will deteriorate the surface mopping with a subsequent increase in the transmission of water vapor.

Before condensation problems and the need for vapor seal courses were fully understood, many cases of leakage were attributed to failure of the roofing. These "leakages" were due to the omission of the vapor seal in structures having unusually high inside humidities or which were exposed to frigid outdoor temperatures. Under these conditions, water vapor will be transmitted from inside the building, through the ceiling and into the insulation, with condensation taking place below the roofing plies adjacent to the insulation or within the roofing plies where there is poor adhesion. After long periods of exposure to these conditions, a large quantity of frost may accumulate. Upon a rise in outdoor air temperature, or exposure to solar radiation even where air temperatures are below freezing, this frost will melt and the moisture will drip back into the building.

The importance of insulation in roof decks in reducing heat flow and interior surface condensation is an accepted fact. It is also acknowledged that moisture content in amounts greater than normal of 5 to 10 per cent will reduce the efficiency of the insulation. However, there have been disputes as to the advantages of one type of insulation over another, especially in regard to the fiber structure. Regardless of the type of fibers, the air cells which are formed between the fibers of any insulation are the primary factors which affect its insulating qualities. These air spaces may become fully saturated with moisture just as air that is not confined may become saturated. This condition may result in the accumulation of free moisture within the air cells and have the same effect as moisture absorbed by the fibers in the insulation. In vegetable fiber insulating board, the fibers will absorb moisture as well as the air cells, and under normal conditions this will vary between 5 and 10 per cent. Mineral fibers do not absorb moisture in amounts of any significance, but the air cells within this type of insulation may become fully saturated or contain free moisture. It is the "free moisture" with which we are primarily concerned. Thus the term "insulation" is used without discrimination in consideration of the moisture problem.

Where pressures are developed due to heating of the roof covering, greater pressures are created within sealed pockets of the roofing plies than within the insulation. This is due to the existence of higher temperatures in the roofing than in the insulation because of the temperature drop from the outside to the

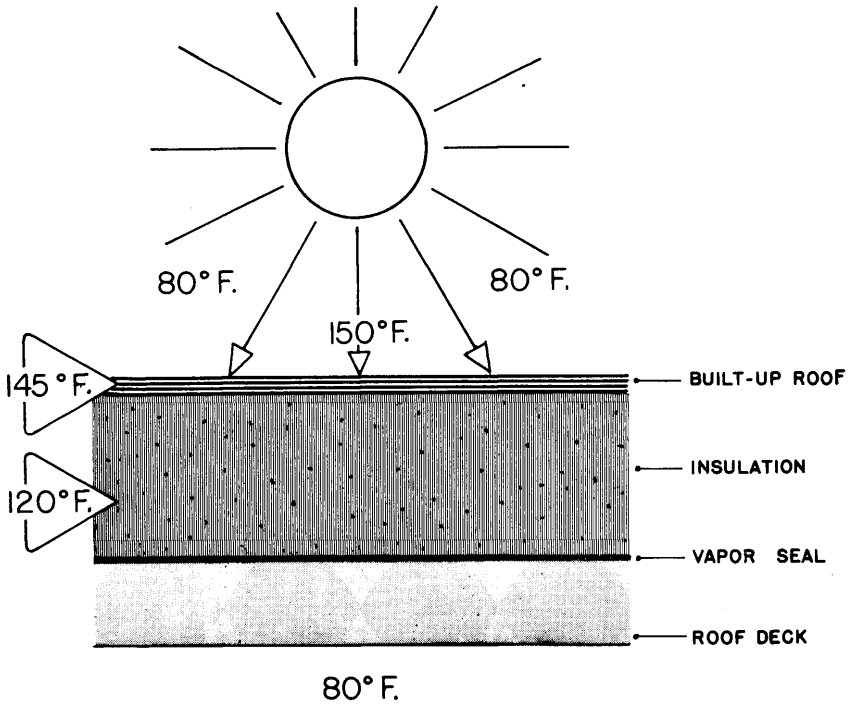

Temperatures Within a Roof Deck Exposed to Solar Radiation

inside of a deck. Moreover, the pressures will tend to equalize throughout the porous insulation within the areas of the headers or cut-offs when such are used. Thus, high localized concentrations of moisture within the insulation may not create as serious a pressure as those which occur within the plies of the roofing.

IX. CONCLUSIONS

In reviewing the many factors which contribute to the satisfactory performance of a built-up roof, one point stands out above all others; namely, construction of a satisfactory roof is possible only when high standards are maintained in *all* phases of its construction. Failure in one respect will negate perfection in other respects. A built-up roof will fulfill its functions only so long as each of its component parts contributes adequately to the performance of the entire unit.

These conditions can be attained and most roof failures avoided if the recommendations listed below are followed:

1. Solidly mop all plies of roofing felts.
2. Avoid the use of roofing materials having a high moisture content.
3. Do not apply a roof during inclement weather or upon a deck which is not thoroughly dry.
4. Exercise rigid control over the temperature of the bitumen.
5. Thoroughly broom down all felt as quickly as possible following the application of the bitumen.
6. Construct roofs according to proved and accepted specifications.
7. Use special precautions when applying roofs to concrete decks in order to prevent the residual moisture of the concrete from entering into the roof structure. This may be accomplished by using a vapor seal course or by positive sealing of the surface.
8. A vapor seal course must be used over all roof decks in cold climates and in temperate climates wherever conditions of high inside humidity exist. A vapor seal course must also be used where the roof deck itself contains an appreciable amount of moisture. To be effective, this vapor seal must be applied according to accepted specifications.
9. Emphasis on good workmanship and field control governing specifications and material is imperative.

The results of the survey of roofing contractors in the three sections of the country not only confirmed the above recommendations, but showed a marked correlation between their opinions derived from experiences in the field, and the results obtained from laboratory investigations.





APPENDIX A

DESCRIPTION OF TEST APPARATUS

Three major types of apparatus were used in investigating the factors affecting built-up roof structures. They consisted of (1) vapor permeability test equipment for determining the vapor transmission rates through built-up roofing and vapor seal courses, (2) vapor transmission apparatus in which complete insulated built-up roofing specimens were subjected to simulated winter field conditions, and (3) summer weathering apparatus which permitted study of complete insulated built-up roof specimens under simulated summer field conditions. A detailed description of each type of apparatus is presented under the appropriate heading below.

A-1. VAPOR PERMEABILITY TEST APPARATUS

The vapor transmission test apparatus used to determine the vapor permeability of built-up roofing and vapor seal courses consists essentially of a refrigerated room surrounded by five vapor sealed warm test cells as shown in the plan drawing of Figure A-1. Figure A-2 shows a

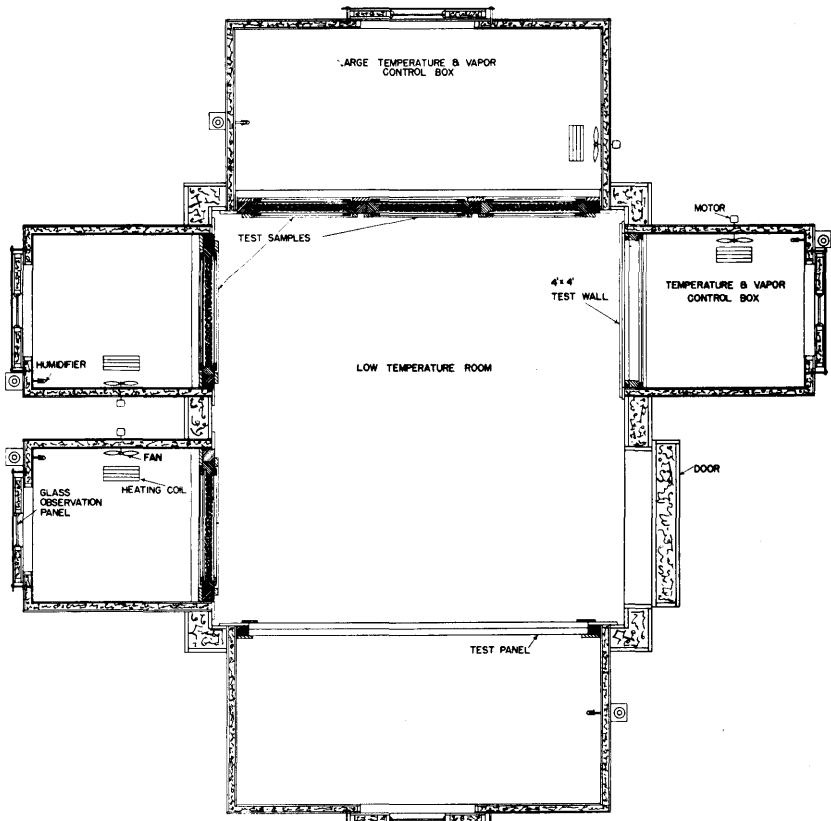

Figure A-1. Plan View of Vapor Permeability Test Apparatus

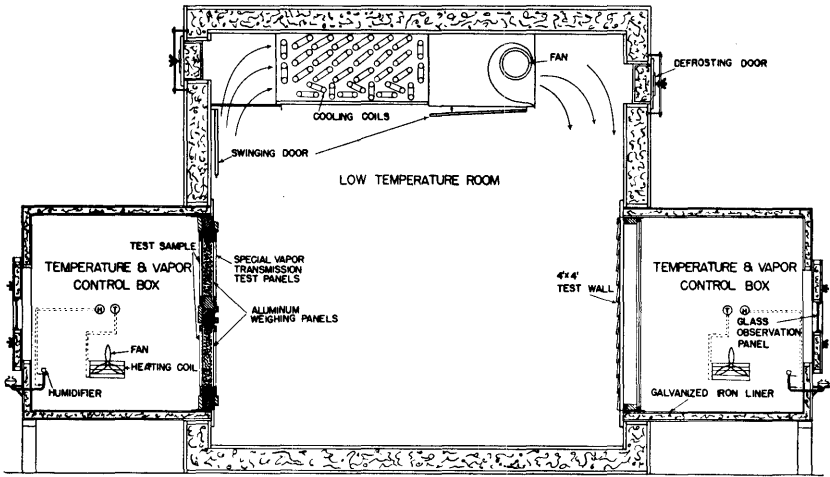

Figure A-2. Sectional View of Vapor Permeability Test Apparatus

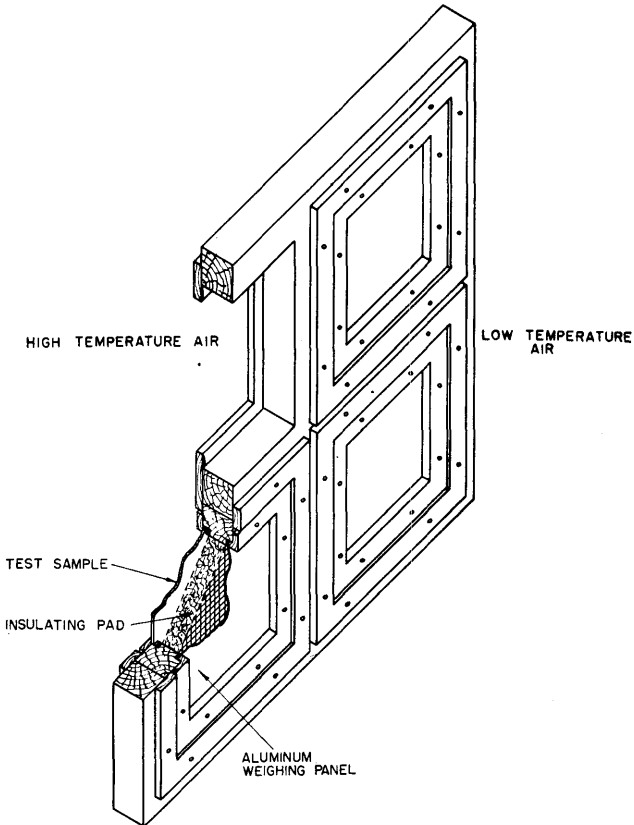

Figure A-3. Vapor Permeability Test Assemblies for Individual Specimens

sectional elevation through two of the three small warm test cells. When the specimens are installed for testing, they form a common wall between the refrigerated room and the warm test cell so that one surface of the specimen assembly is exposed to warm inside air conditions and the other surface is exposed to the cold outside air. The temperature in the cold room is automatically controlled at -10° F, and the air conditions within the warm cell are maintained at 70° F and 40 per cent relative humidity. Higher or lower relative humidities may be attained when necessary. The difference in water vapor pressure of the air between the warm cell and the cold room (approximately 0.28 inch of mercury) causes the water vapor to flow through the specimen from the warm side. The rate of water vapor transmission, which depends on the materials composing the test specimen, is expressed in grains per square foot per hour per inch of mercury vapor pressure difference and is designated as the vapor permeability of the materials.

All tests for this phase of the investigation were conducted using $14\frac{3}{4}$ - by $15\frac{3}{4}$ -inch specimens mounted in special small panel test frames. Secondary frames were inserted in the wall openings between the cold room and the warm test cells to accommodate the small panel test assemblies.

The small panel specimen holding frames, which are shown mounted in the secondary frame in Figure A-3, consist of 17- by 18-inch wood frames treated to make them impermeable to water vapor. Two-inch

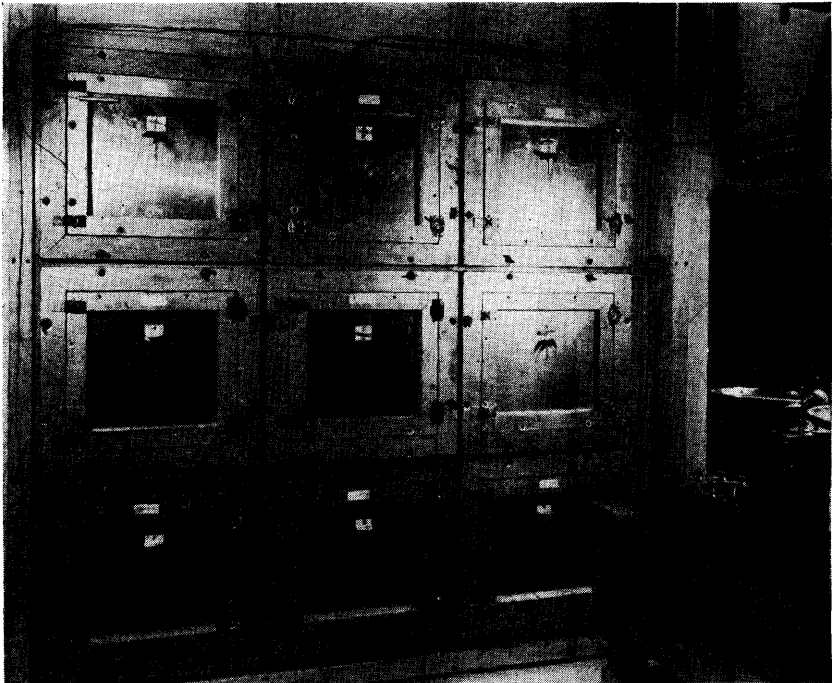

Figure A-4. Vapor Permeability Test Assemblies as Viewed from the Cold Side

thick insulating pads of known resistance to water vapor flow are inserted in the 13 $\frac{3}{4}$ - by 14 $\frac{3}{4}$ -inch test opening. The built-up roofing or vapor seal course specimens are sealed with paraffin in a recess on the warm side of the specimen holding frames. Aluminum collecting plates are sealed against gaskets on the cold side of the specimen holding frames by means of hinged frames which are equipped with sash locks. A $\frac{1}{8}$ -inch air space separates both the specimen and the condensing plate from the insulating pad. A thermocouple is mounted on each condensing plate to measure the temperature of the plate, which varies for the different specimens. The complete test panel assemblies are then installed in the secondary frame, which has previously been sealed into the test opening between the warm cells and the cold room. A photograph taken from the cold room showing nine individual test panel assemblies, installed in the secondary frame, is shown in Figure A-4.

During the progress of the test, water vapor which passes through the specimen is condensed in the form of frost on the aluminum condensing plate. The aluminum plate is weighed to the nearest 0.1 gram at 48-hour intervals and the test continued until several successive weighings are obtained, indicating that equilibrium conditions have been established to obtain a constant rate. Temperature, humidity, and condensing plate temperatures are measured three times daily. At the end of the test, temperature readings, taken during the period of uniform frost accumulation, are averaged to provide data for computing the vapor permeability on the basis of unit vapor pressure difference across the specimen.

A-2. VAPOR TRANSMISSION AND WINTER WEATHERING APPARATUS FOR TESTING BUILT-UP ROOF SPECIMENS

The apparatus for testing the vapor permeability of built-up roof specimens in a horizontal position is shown in Figures A-5 and A-6. It consists basically of an insulated room approximately 8 feet cubed with one end open to the refrigerated room described for the vapor permeability apparatus. This room is partitioned to provide cold air above the horizontal test specimens and a warm air conditioned space below. Six horizontal openings, three on each side of a central service aisle, are provided to accommodate the 22- by 22-inch test specimens. Air, at controlled temperature and humidity conditions, is circulated on the warm side through a system of ducts in which are located electric heaters, humidifying apparatus and control equipment. The temperature of the cold space is controlled from the refrigerated room through the use of an auxiliary fan located in the opening between the two refrigerated rooms. Infra-red lamps are mounted above the test specimens, as shown in the photograph, Figure A-6, to provide a simulated solar radiation cycle during the winter weathering tests. Thermocouple stations are arranged to permit temperature measurements at any point in the built-up roof specimens as well as in the adjacent air on the warm or cold side of the specimen.

A holding frame for the built-up roof specimens is shown in Figure A-7. It is constructed so that any variation in the thickness of the built-up roof may be compensated for and insures that the roofing felt or the

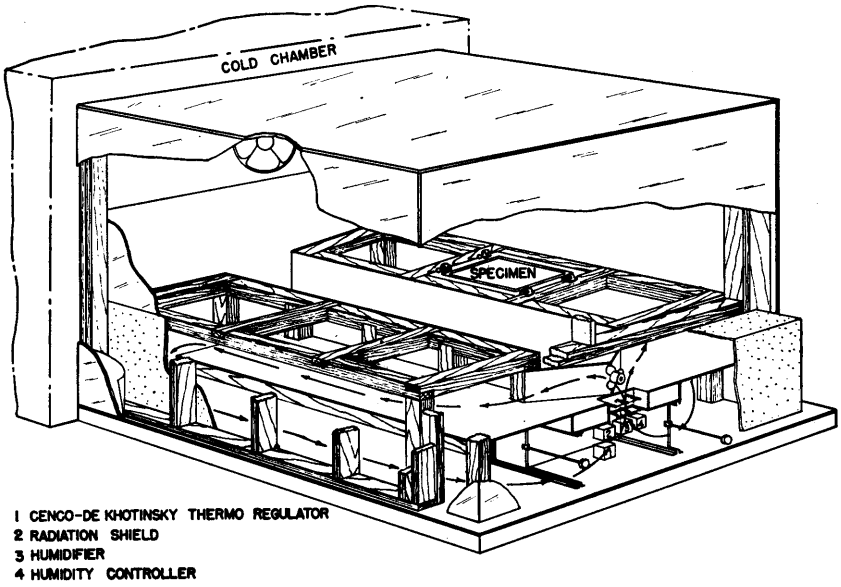

Figure A-5. Vapor Transmission Apparatus for Testing Built-up Roof Sections

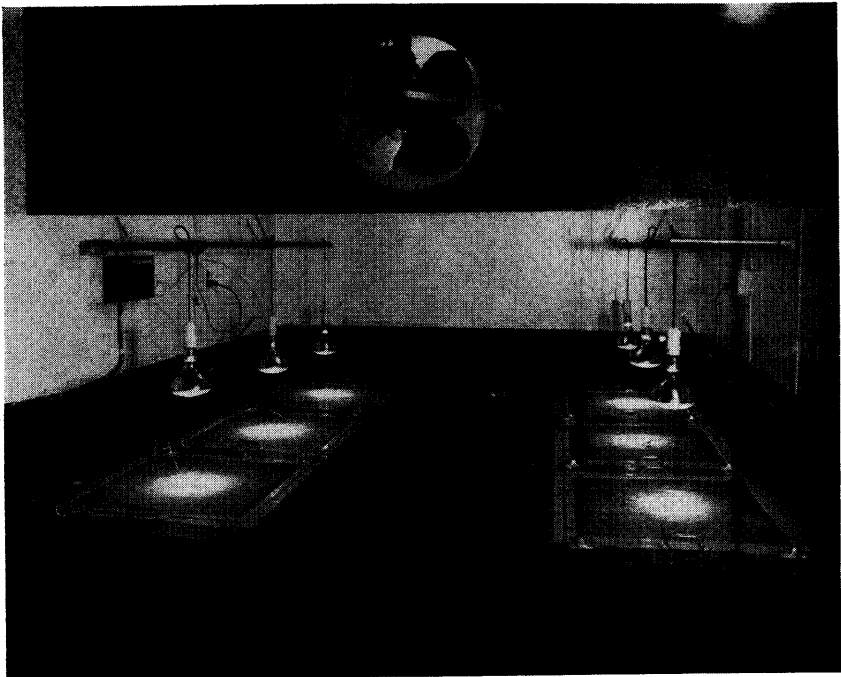

Figure A-6. Winter Weathering Specimens Subjected to Infra-Red Radiation

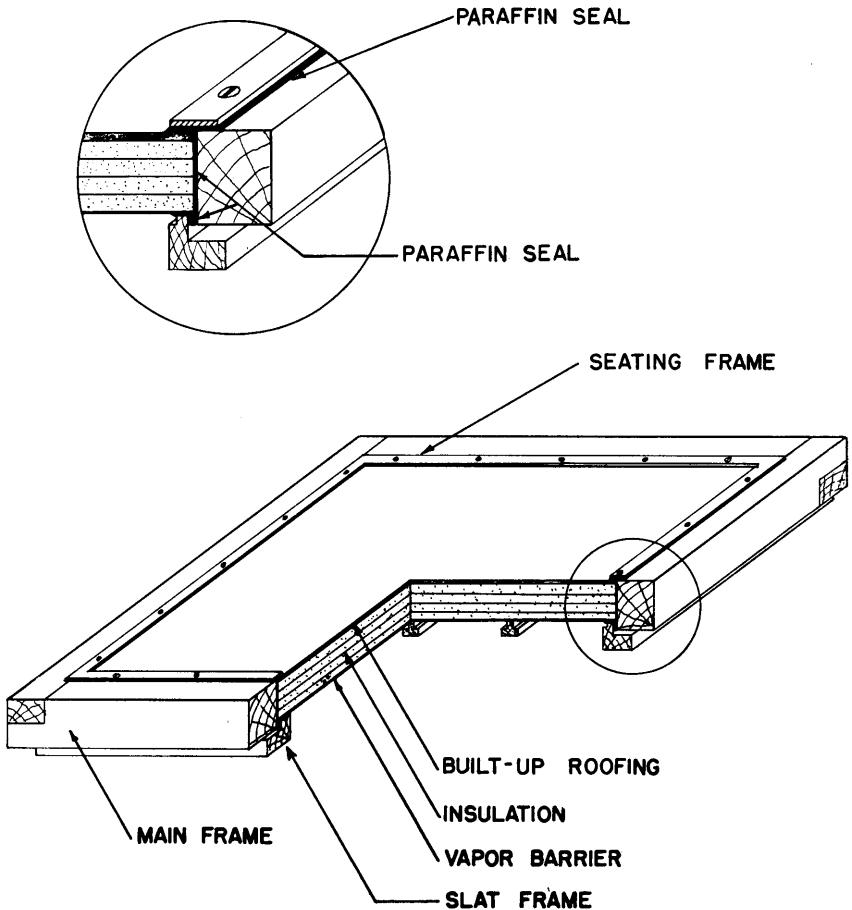

Figure A-7. Construction of Roof Test Sections

top exposed part of the test specimen is flush with the top of the test frame. One component of the holding frame is a slat frame attached to the warm side for supporting the vapor seal course. These slats are ribbed to provide a minimum contact area with the vapor barrier and are located so that they are parallel to the direction of air flow on the warm side. This method of construction of the holding frame provides the following flexibility:

1. Permits mounting of a specimen which may vary between 2 and 2½ inches in thickness
 2. Provides for complete vapor sealing of the specimens in the frame
 3. Allows for inspection of the underside of the built-up roofing during the progress of the test without damage to the specimens.
- Before installing a completed section of built-up roofing in the test frame, all edges are sealed with adhesive tape followed by a continuous

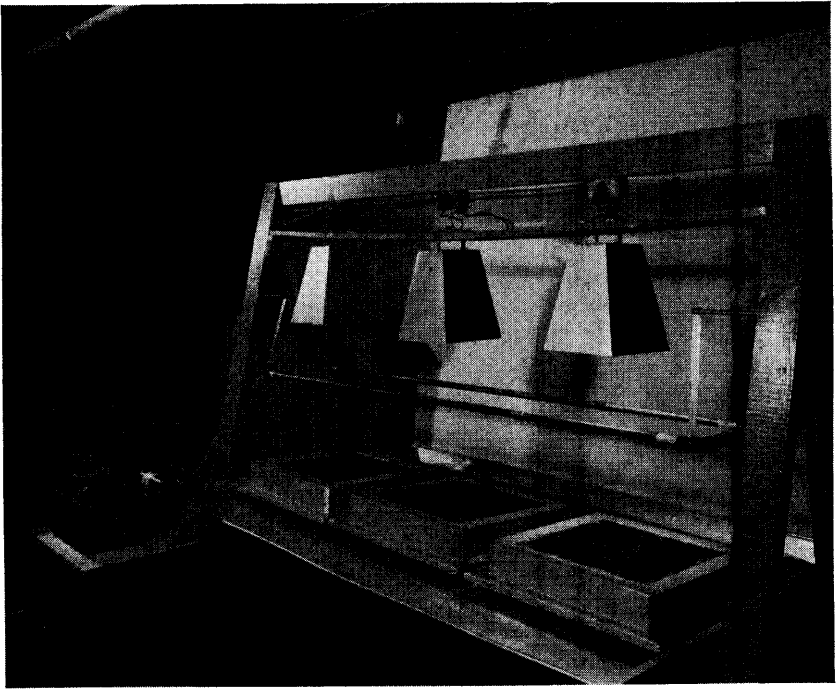

Figure A-8. Roof Specimens Exposed to Summer Weathering

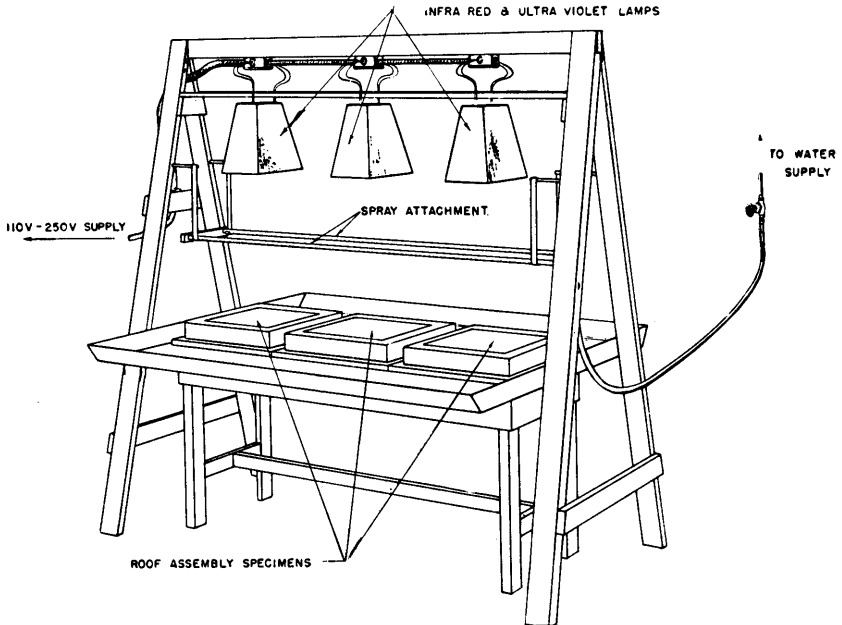

Figure A-9. Summer Weathering Test Apparatus

coating of paraffin. The entire unit is then clamped in the frame, after which it is sealed with paraffin in order to eliminate any leaks between the frame and the test specimen on either the warm or the cold side.

A-3. SIMULATED SUMMER WEATHERING APPARATUS

The apparatus constructed to provide simulated summer weathering conditions for the specimens is shown in Figures A-8 and A-9. The apparatus consists essentially of a support for ultra-violet and infra-red lamps and a section of perforated pipe through which water is sprayed on the specimens contained in the large tray below. The lamps are supported above the specimens by a method which permits adjustment of height and thus allows control of the specimen surface temperature. Rate of water flow through the perforated section of pipe is regulated by a gate valve in the line connecting to the water supply. The tray in which the specimens are supported is inclined at an angle of approximately $\frac{3}{4}$ inch per foot to permit draining of both the specimen surface and the tray itself. A drain line at the low edge of the tray disposes of water collecting in the tray. Thermocouples imbedded in the roofing surface of the specimens and connected to a portable potentiometer provide the means for determining the surface temperature of specimens in test.

The special small panel specimen holding frames which were described for the vapor permeability apparatus were adapted to hold complete $14\frac{3}{4}$ - by $15\frac{3}{4}$ -inch built-up roof specimens for these tests.

APPENDIX B

RESEARCH STUDIES OF BUILT-UP ROOF STRUCTURES

B-1. CONSTRUCTION OF BUILT-UP ROOF SPECIMENS

Since the investigation involves a study of typical built-up roof structures, it was necessary to select types of specimens which would be representative of the different types of built-up roofs which are applied in the roofing industry. The original program provided for investigating typical 10-, 15-, and 20-year guarantee types of roofing with the preliminary tests being confined to the 10-year type of roofing only.

All test panels were constructed by a local roofing contractor according to different commercial specifications which are described later. The Engineering Experiment Station supervised the construction and recorded the data pertaining to types and weights of materials used. The panels were constructed on a deck of 2-inch thick insulation board so that the roofing materials could be nailed according to specifications and removed from the deck without difficulty. The protruding nails were clipped off flush with the under surface of the roofing before the specimens were placed in test. The panels were constructed in 8-foot square sections after which a strip, one foot wide, was trimmed from the four edges to eliminate edge irregularities. The remaining 6-foot square panels were then cut into nine 2-foot square specimens which were stored until required for test. When nails were used for the first course of felt, as would be the case for a wood deck, they were driven directly into the insulation board construction deck. However, where the first course would normally be mopped to the deck (as in the case of concrete decks), the first course was laid without mopping and the mopping coat was applied to the under surface after the panel was removed from the insulation board deck. Construction details for the roofing are shown in Figures B-1 through B-4 inclusive. Panels 1 and 1-A are identical except that the regular felt used in Panel 1 was replaced by perforated felt in Panel 1-A. Asphalt coatings were used throughout except for Panel 3 which was mopped with coal tar pitch. Solid mopping of the roofing felts was specified in every case.

The following specifications, selected for the initial investigation, are all based upon the 10-year type of construction.

Panel 1 (Figure B-1)

- (a) A single layer of 30-pound felt was lapped 2 inches and laid dry; all sheets were 36 inches wide with side laps nailed 6 inches on center. The felt was also nailed 18 inches on center at 12 inches and 23 inches from the upper edge. Two end laps were provided in each panel, consisting of a 6-inch lap located 2 feet from the right-hand edge near the bottom of the panel and 30 inches from the left-hand side near the top.

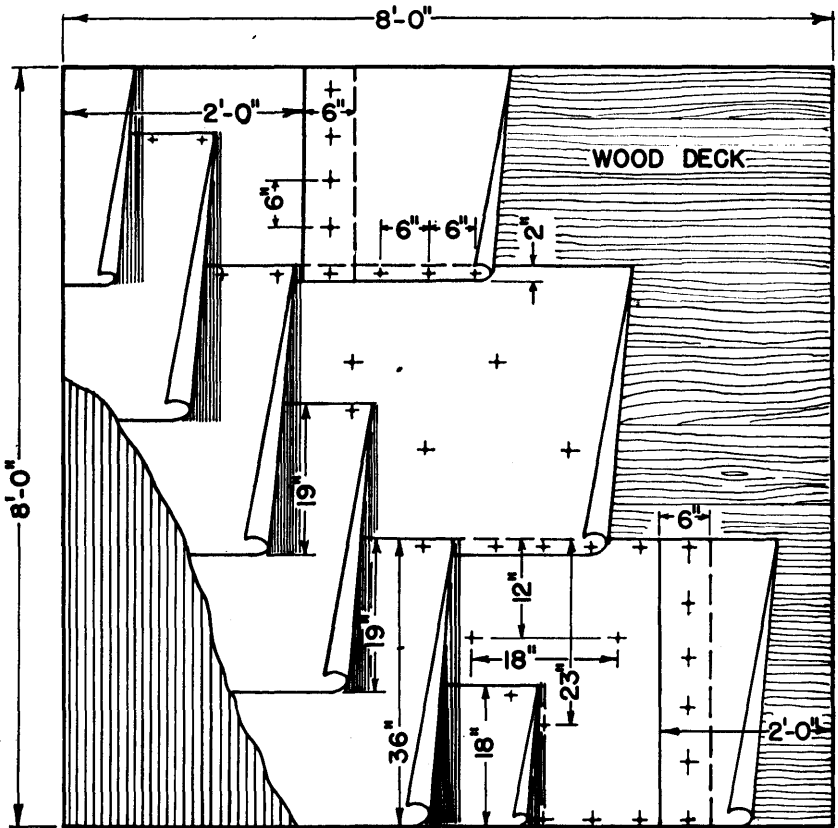

Figure B-1. Roofing Panels 1 and 1-A

- (b) Two layers of 15-pound asphalt felt were lapped 19 inches and solidly mopped with 30 pounds of asphalt per square. Each layer of felt was nailed 1 inch from the upper edge and approximately 36 inches on center for tacking purposes only prior to mopping.
- (c) The final surface was then solidly mopped with 30 pounds of asphalt per square.

Panel 1-A

Same as Panel 1, except that the 15-pound regular asphalt felt was replaced by 15-pound perforated felt.

Panel 2 (Figure B-2)

- (a) Three layers of 15-pound asphalt felt, lapped 25 inches, were mopped solidly to the deck with 30 pounds of asphalt per square. All felt was 36 inches wide and applied in this width, except as noted when applying the first two courses near the bottom of the panel.

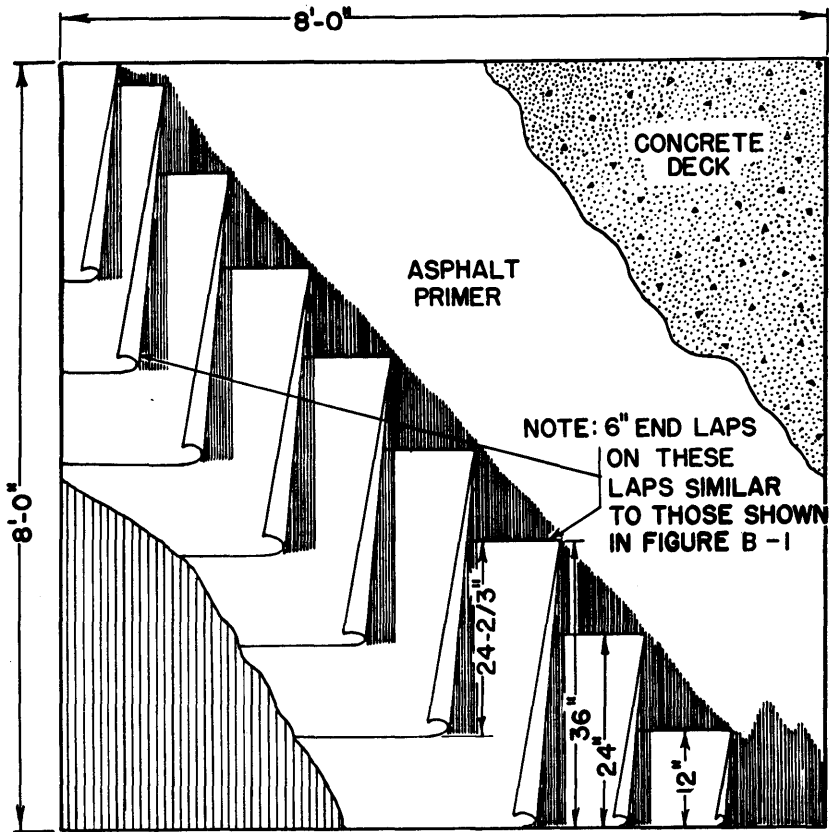

Figure B-2. Roofing Panel No. 2

- (b) The final coating consisted of 30 pounds of asphalt per square solidly mopped over the entire surface.

Panel 3 (Figure B-3)

- (a) Thirty-six inch sheets of unsaturated tarred felt weighing not less than 5 pounds per square were laid directly on the deck and lapped 1 inch.
- (b) Thirty-pound tarred felt, in sheets 36 inches wide, was applied and lapped 4 inches with the laps nailed in place. End laps were provided near the lower right-hand corner of the panel approximately 2 feet from the right-hand edge, and in the upper corner approximately 30 inches from the left-hand edge. The 6-inch end laps were nailed 6 inches on center. Side laps were also nailed 6 inches on center. The entire surface was then solidly mopped with 25 pounds of pitch per square.

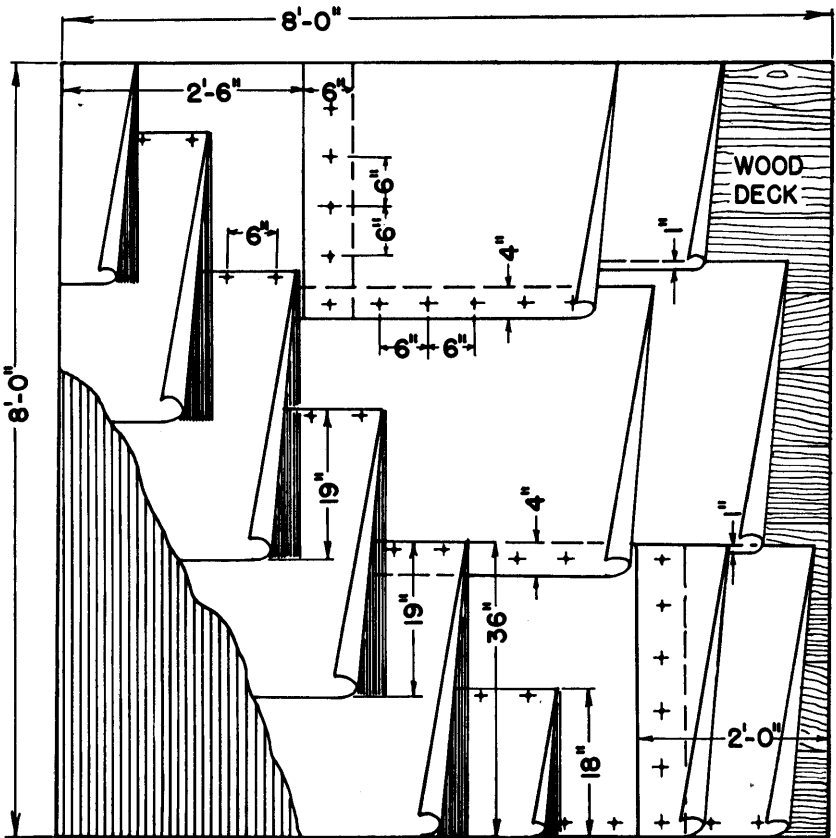

Figure B-3. Roofing Panel No. 3

- (c) Two layers of 15-pound tarred felt were then applied and lapped 19 inches and nailed 1 inch from the upper edge 6 inches on center. Each lap was solidly mopped with pitch at the rate of 25 pounds per square. All nailed edges were covered with two plies of felt.
- (d) The top surface was solidly mopped with 25 pounds of pitch per square.

Panel 4 (Figure B-4)

- (a) Thirty-pound asphalt saturated felt was laid dry and lapped 2 inches. The felt was nailed 6 inches on center at the side laps and 18 inches on center through the center of each sheet on two lines spaced 11 inches apart with the nails staggered. End laps were provided in both the lower right-hand and upper left-hand corners of each panel, as shown in Figure B-4.

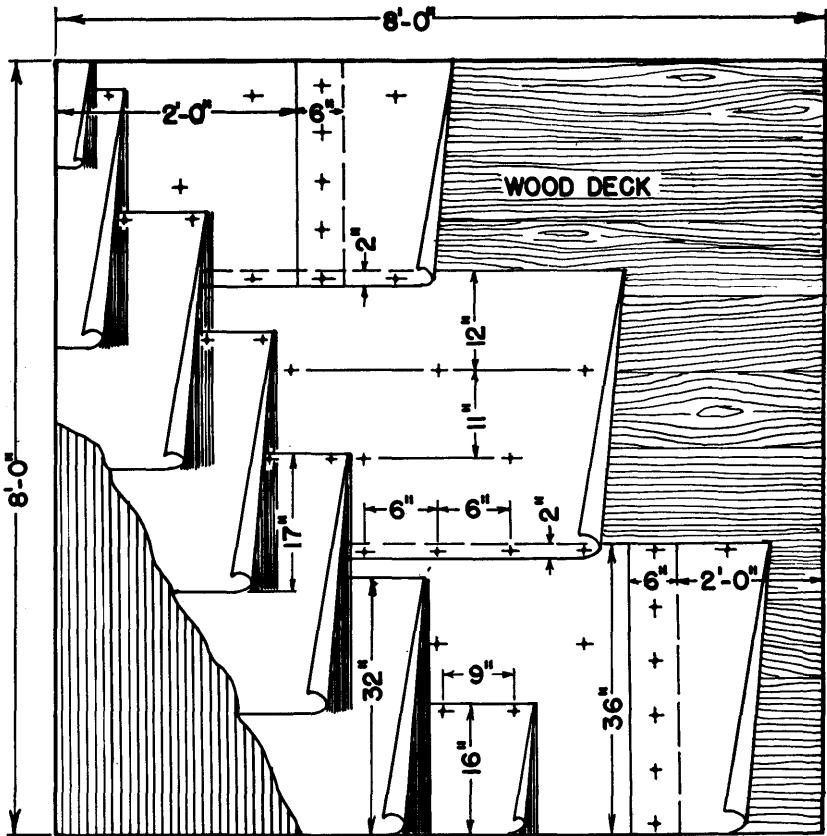

Figure B-4. Roofing Panel No. 4

- (b) Two layers of 15-pound asphalt saturated asbestos felt in sheets 36 inches wide were applied and lapped 17 inches. Each lap was mopped full width with 30 pounds of asphalt per square. The back edge of each sheet was nailed 9 inches on center at the side laps.
- (c) The top surface was solidly mopped with 1 gallon of asphalt per square.

The actual quantities of various coatings used in construction of the different panels are shown in Table B-I with the approximate weights designated in the preceding description of the panels. All weights are given in pounds per square and were determined during the time of construction by weighing the vessel containing the asphalt or pitch before and after each particular application. In Table B-I, columns 3 and 4 pertain to the mopping of the first course of felt to the deck. Columns 5, 6 and 7 refer to the solid mopping of each layer of felt, with the number of mopped layers shown in column 5, and the approximate specified

weight and actual weight used for each mopped layer shown in columns 6 and 7, respectively. The weight of the top surface coating, as specified and as actually applied, is shown in the next two columns, respectively. In order to obtain a relative comparison between the total amount of bitumen actually applied and that specified, the two total weights for each panel have been tabulated in columns 10 and 11, and the ratio in per cent of the total weight applied to the total weight specified is shown in column 12.

B-2. CONSTRUCTION OF VAPOR SEAL COURSE SPECIMENS

Four types of vapor seal courses which are representative of the types being applied in the field were selected for test and constructed according to commercial specifications. The vapor seal course panels were constructed on a 2-inch thick insulation board deck in the same manner as were the roofing samples. Wherever an initial undercoat of bitumen was specified, it was mopped on the under surface of the course after the

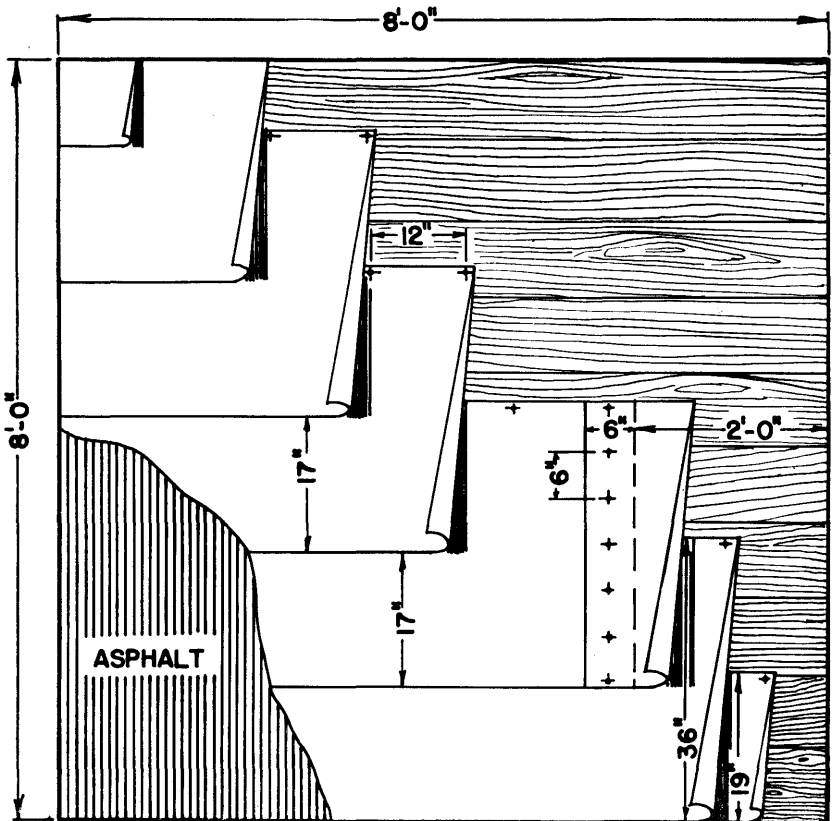

Figure B-5. Vapor Seal Course Panel 1-V

panel was removed from the deck. Asphalt coatings were used for all panels except one which was mopped with coal tar pitch. As was the case for the roofing panels, a 1-foot wide strip was trimmed from the four edges of the panel and the remaining 6-foot square panel was cut into nine 2-foot square specimens which were stored until required for test. The panels were constructed, as shown in the detailed drawings of Figures B-5 through B-8 inclusive, according to the following specifications:

Panel 1-V (Figure B-5)

- (a) Two layers of 15-pound felt were laid and lapped half width, or 18 inches, with each sheet nailed on the back edge 12 inches on center. All laps were solidly mopped back 17 inches with 30 pounds of asphalt per square.
- (b) The top surface was solidly mopped with 30 pounds of asphalt per square.

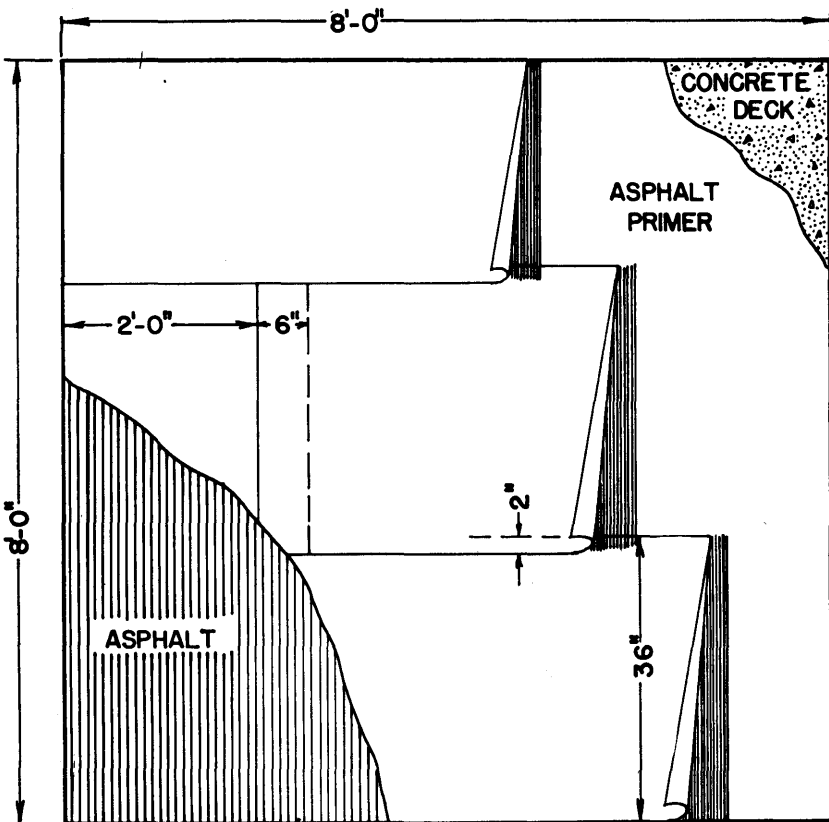

Figure B-6. Vapor Seal Course Panel 2-V

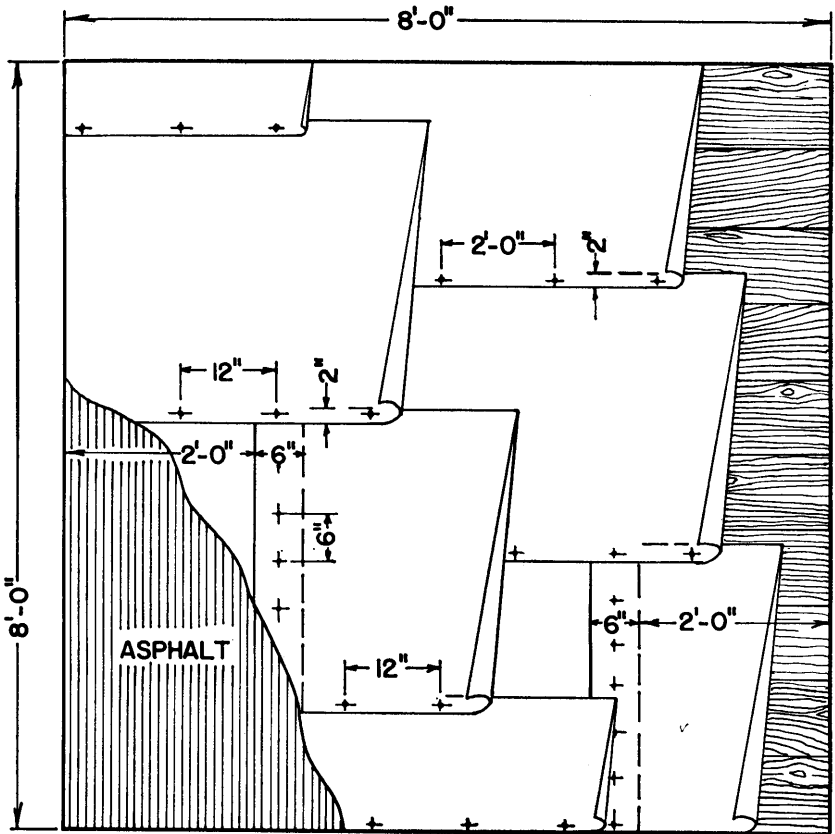

Figure B-7. Vapor Seal Course Panel 3-V

Panel 2-V (Figure B-6)

- (a) One layer of 15-pound felt was laid in 30 pounds of asphalt per square.
- (b) The top surface was solidly mopped with 30 pounds of asphalt per square.

Panel 3-V (Figure B-7)

- (a) One layer of rosin sheathing paper was lapped 2 inches and nailed in place.
- (b) One layer of 15-pound felt was nailed 12 inches on center at the side laps.
- (c) The felt was solidly mopped with 25 pounds of coal tar pitch per square.

TABLE B-I

Weights of Asphalt and Tar Coatings Used in Construction of Built-Up Roofing and Vapor Seal Courses

Panel No.	Description	Weight of Coatings (Pounds per square)									
		Deck		Coatings between each ply			Top Coating		Total Weights of Coatings		
		Spec.*	Applied†	No.	Spec.	Applied	Spec.	Applied	Spec.	Actual	Ratio, per cent
(1)	(2)	(3)	(4)	(5)	(6)	(7)	(8)	(9)	(10)	(11)	(12)
Built-up Roofing											
1	3-ply asphalt	2	30	21.1	30	26.6	90	68.8	76.6
1A	3-ply asphalt	2	30	16.8	30	21.1	90	66.5	74.0
2	3-ply asphalt	30.0	12.5	2	30	19.1	30	25.8	120	76.6	64.0
3	4-ply pitch	2	25	18.7	50	53.1	100	90.5	90.0
4	3-ply asphalt	2	30	18.4	8	6.9	68	43.7	64.5
Vapor Seal Courses											
1-V	Asphalt saturated rag felt over wood deck	1	30	21.9	30	25.8	60	47.7	79.5
2-V	Asphalt saturated rag felt over concrete deck	1	30	21.4	30	27.4	60	53.8	89.6
3-V	Tar saturated rag felt over wood deck	25	27.3	25	27.3	109.2
4-V	Saturated and coated felt over wood deck	30	26.8	30	36.8	122.7

* Specified application.

† Actually applied.

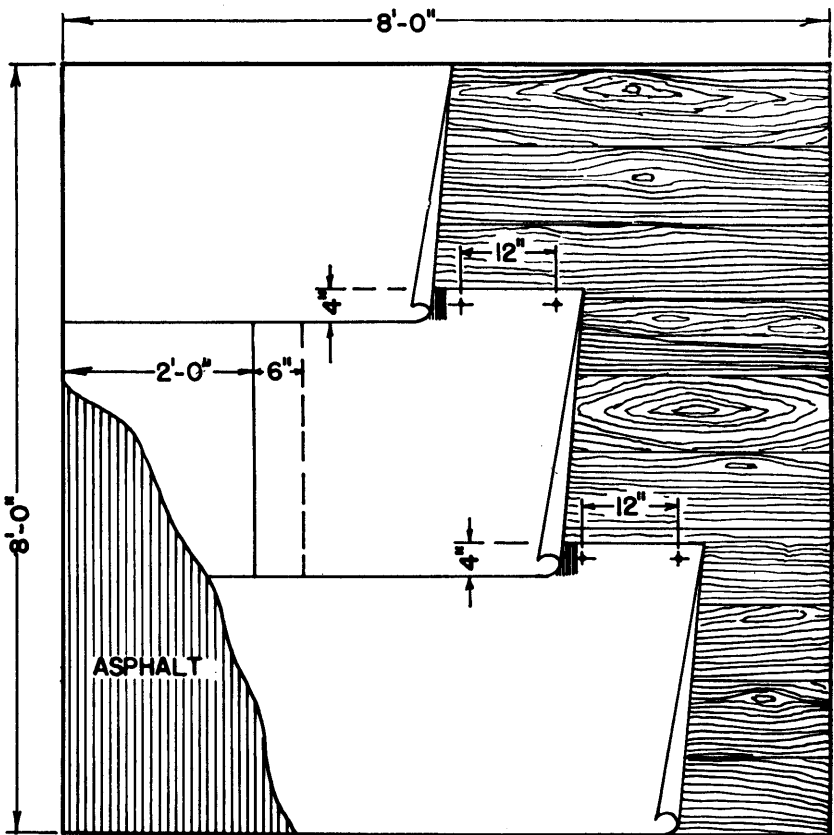

Figure B-8. Vapor Seal Course Panel 4-V

Panel 4-V (Figure B-8)

- (a) One layer of 45-pound base felt was laid with coated side down and lapped 4 inches. The back edge of each sheet was solidly mopped and nailed 12 inches on center.
- (b) The top surface was solidly mopped with 30 pounds of asphalt per square.

The actual weight of bitumen applied for the various coatings of the different vapor seal specimens is shown and compared with the specified weights in Table B-I.

B-3. VAPOR PERMEABILITY OF ROOFING AND VAPOR SEAL COURSE

Vapor permeability tests were conducted on the five 10-year types of built-up roofing described in the specifications of Appendix B-1. One specimen, which contained no lapped joints, was selected from those cut

from each panel and trimmed to $14\frac{3}{4}$ by $15\frac{3}{4}$ inches for installation in the special small panel specimen holding frames described in Appendix A-1.

To determine the effect of lapped joints on the vapor permeability of roofing, specimens having lapped joints in the test section were selected from each of the five 10-year type built-up roofing panels and tested for vapor permeability.

Similarly duplicate specimens with and without lapped joints of the four different types of vapor seal courses, which are described in the specifications of Appendix B-2, were also subjected to vapor permeability tests.

All tests were conducted in the vapor permeability test apparatus (Appendix A) under identical conditions. The air on the warm side was stabilized at 70° F and 40 per cent relative humidity and the air on the cold side was controlled at -10° F. The tests were continued for a period of 45 days for the roofing samples and 28 to 60 days for the different vapor seal courses.

TABLE B-II
Vapor Permeability of 10-Year Built-Up Roofing

Panel No.	Type of Roofing	Test Duration in Days	Permeability Gr/sq ft/hr/in.Hg	Remarks
1-a	3 ply asphalt	45	0.0	Lap in panel
1-b	3 ply asphalt	45	0.0	No lap in panel
1A-a	3 ply asphalt	45	0.0	Lap in panel
1A-b	3 ply asphalt	45	0.0	No lap in panel
2-a	3 ply asphalt	45	0.0	Lap in panel
2-b	3 ply asphalt	45	0.0	No lap in panel
3-a	4 ply pitch	45	0.0	Lap in panel
3-b	4 ply pitch	45	0.0	No lap in panel
4-a	3 ply pitch	45	0.0	Lap in panel
4-b	3 ply pitch	45	0.0	No lap in panel

TABLE B-III
Vapor Permeability of Vapor Seal Courses

Panel No.	Description	Test Duration in Days	Permeability Grs/sq ft/hr/in. Hg
1-V-a	Asphalt saturated rag felt over wood deck	31	0.0
1-V-b	Asphalt saturated rag felt over wood deck	31	0.0
2-V-a	Asphalt saturated rag felt over concrete deck	28	0.0
2-V-b	Asphalt saturated rag felt over concrete deck	28	0.0
3-V-a	Tar saturated rag felt over wood deck	28	0.0
3-V-b	Tar saturated rag felt over wood deck	28	0.0
4-V-a	Saturated and coated felt over wood deck	60	0.0
4-V-b	Saturated and coated felt over wood deck	60	0.0

Test Results

The results of the tests on built-up roofing (with and without lapped joints) and on vapor seal courses are presented in Tables B-II and B-III, respectively, and indicate that all specimens have a zero permeability rate.

Conclusions

The test results show that the specimens, which were selected as being representative of most 10-year types of built-up roofing and vapor seal courses, are, when properly constructed according to accepted specifications, impermeable to vapor transmission. The results also show that properly constructed lapped joints are equally impermeable. It should be noted, however, that these results were obtained for specimens prepared under ideal conditions of construction and do not indicate the effect of such variables as workmanship, weather, materials and method of application.

The vapor permeability of 15- and 20-year types of built-up roofing was not investigated. Since the 10-year type roofing specimens proved impermeable to vapor, it was assumed that the 15- and 20-year types would be equally impermeable to water vapor.

B-4. EFFECT OF SIMULATED WINTER WEATHERING ON THE VAPOR PERMEABILITY OF ROOFING

For this investigation, tests were planned which would simulate the winter weathering conditions in the field for the purpose of investigating conditions existing within typical roof structures during winter months and the effect of those conditions on the performance of built-up roofing. Although there is no positive correlation between the laboratory tests and actual field conditions, it was felt that the test conditions imposed were severe enough to provide an index to what may be expected.

Test Specimens

The test specimens, which were 22 inches square, were constructed with 10-year type built-up roofing on the cold side and 2 inches of fiber-board insulation consisting of four layers of ½-inch thick boards stapled together. The roofing was solidly mopped to the insulation with asphalt applied at the rate of 30 pounds per square. Method of installing the specimen in the holding frame is shown in Figure A-7, with the exception that asphalt was substituted for paraffin as a sealing agent to prevent possible melting during periods of heat application.

In order to determine the effect of installing insulation of high moisture content, the insulation board included in three of the six specimens was submerged in distilled water until it attained a moisture content in excess of 15 per cent. The insulation board in the remaining three specimens was installed at normal moisture content for the room air conditions at the time of test, or approximately 5 per cent by weight. Two specimens, one having the artificially induced high moisture content and the other having the low moisture content, were covered on the warm

side by the same type of vapor barrier in order that the effect of initial moisture content acting in conjunction with barriers of various permeabilities could be observed in test. The vapor barriers used on each of the six specimens, the permeability of the barrier and the actual moisture content of the insulation board contained in the specimen are shown in Table B-IV.

TABLE B-IV
Construction Details for Winter Weathering Test Specimens

Specimen No.	Vapor Barrier	Vapor Barrier Permeability Gr/sq ft/hr/in. Hg	Moisture Content of Insulation Board Per cent by Weight
A	None	21.1
B	50 lb surface-treated kraft paper	3.93	17.8
C	Vapor seal course	0.00	17.3
D	None	4.7
E	50 lb surface-treated kraft paper	3.93	4.7
F	Vapor seal course	0.00	4.7

Test Conditions and Results

The accelerated winter weathering tests were conducted in the roof structure vapor transmission apparatus described in Appendix A. Air conditions on the warm side of the specimens were maintained constant at 70° F and 60 per cent relative humidity during the 62-day test period. Heat was applied to the roofing surface of the specimens for 7 hours daily through infra-red radiation. Height of the lamps above the specimens was adjusted to produce a roof surface temperature of 80° F. Air temperature at the control point in the cold room was regulated at -10° F. During periods of heating, the air temperatures (measured 12 inches above the specimens) rose to approximately 0° F. The air temperature within the room during the remainder of each 24-hour period was -10° F. A photograph of the interior of the roofing vapor transmission room showing the special apparatus installed for this test is shown in Figure A-6.

The time required for stabilization of conditions within the roof assembly specimens under similar conditions of exposure was previously determined by preliminary tests as being approximately 50 days. Since the specimens in these tests were exposed for a period of 62 days, there is positive assurance that conditions within the roof specimens were completely stabilized. At the end of the test, the specimens were removed from the cold room and visually inspected. The results of the test showed that the 10-year type built-up roofing on all specimens appeared to be in good condition, with no evidence of blistering or warping on the surface.

Following this test, the roofing was removed from the insulation and tested for vapor permeability in the vapor permeability test apparatus. The vapor permeability rates shown in Table B-V, were found to vary from 0.07 grain to 0.17 grain, with an average of 0.10 grain per square foot per hour per inch of mercury for the six samples. Except as

an indication of a trend in increasing permeability the increase in permeability rates are so insignificant that for all practical purposes the roofing may be regarded as being impermeable. Thus, the effects of simulated weathering exposure upon the roofing appeared to be negligible and it is improbable that any noticeable effect on the roof structure would occur during the normal life of the roof.

B-5. EFFECT OF SIMULATED SUMMER WEATHERING ON THE VAPOR PERMEABILITY OF BUILT-UP ROOFING

Due to the apparent occurrence of a majority of roof failures during the spring and summer months, it was believed that heat induced by solar radiation was a major factor contributing to these premature failures. Consequently, a test was planned which would permit observation of the effect of simulated summer weathering conditions on three different roof specimens. The specimens were 14¾ inches by 15¾ inches and were constructed with 10-year type built-up roofing as a weatherside covering. Each contained 2 inches of fiberboard insulation consisting of four ½-inch boards stapled together. A standard type of vapor seal course covered the underside of two specimens and no vapor barrier was used on the third specimen. The insulation contained in one of the two specimens having a vapor seal course was immersed in distilled water until its moisture content exceeded 18 per cent. The insulation in the two remaining specimens contained approximately 5 per cent moisture which was normal equilibrium moisture content for the room air conditions at the time of test.

The specimens were mounted in the special test frames and the roofing and vapor seal courses were sealed at the junction between the specimen and the frame with a fillet of asphalt. To facilitate removal, neither the roofing nor the vapor seal course was mopped to the insulation board. The specimens were placed in the summer weathering apparatus, described in Appendix A-3, and subjected to the following continuous 24-hour cycle of exposure under room air conditions:

1. Fifteen hours of ultra-violet and infra-red radiation to attain a roof surface temperature of 160° F
2. Seven hours low velocity water spray
3. Two hours at room temperature of approximately 75° F.

During the progress of the tests, visual inspections showed that small bubbles in the asphalt coating on the built-up roofing appeared during the third day. As the test progressed, these bubbles became larger and covered a greater area. The blisters appearing on the specimen having a vapor seal course and insulation of 18 per cent moisture were larger and in greater numbers than those occurring on the other two samples. After 25 days of the test, there was a noticeable pressure formation within this same specimen as was evidenced by bulging of the roofing surface.

The vapor permeability rates of the three roof coverings were determined at the end of the test, after 31 days, and were found to vary

from 0.07 to 0.18, or an average of 0.12 grain per square foot per hour per inch mercury. The test results for the individual specimens are shown in Table B-V.

TABLE B-V

Vapor Permeability of Specimens of Roofing Subjected to Summer Weathering

Spec. No.	Specification	Vapor Seal and Moisture Content of Insulation	Vapor Permeability Gr/sq ft/hr/in. Hg
1	3-ply asphalt	Insulation 5.0 per cent M. C. vapor seal course	0.11
2	3-ply asphalt	Insulation 18.0 per cent M. C. vapor seal course	0.18
3	3-ply asphalt	Insulation 5.0 per cent M. C. no vapor seal course	0.07

Although there was visual evidence of deterioration of the roofing, the vapor transmission tests show the permeability of this roofing to be only slightly higher than those in the winter weathering tests. Since the permeability rates for these tests are extremely low, they do not indicate a serious change in the roofing, except that summer weathering apparently has some effect on increasing, in a small measure, the vapor permeability rate.

B-6. EFFECT OF COMBINED SUMMER AND WINTER WEATHERING ON THE VAPOR PERMEABILITY OF ROOFING

The purpose of this test was to determine the combined effect of the two types of weathering in producing deterioration of insulated roof structures. In order to accelerate the effect of this weathering, the insulation was conditioned to a moisture content of 14 per cent to provide additional moisture within the roof assembly. Two identical 22-inch square test specimens were constructed by the same method used for the winter weathering tests. Each specimen contained the 10-year type built-up roofing, 2 inches of wood fiberboard insulation consisting of four layers of ½-inch board stapled together, and a vapor seal course. Asphalt was used as a sealing agent in assembling the specimen into the test frames, but the roofing was not mopped to the insulation board.

Both specimens were exposed to consecutive 30-day periods of summer and winter weathering. The cycle for each was identical to those described under the summer and winter weathering, with Specimen "A" initially exposed to winter weathering and Specimen "B" exposed to summer weathering. The specimens were then interchanged so as to be exposed to summer and winter weathering of 30 days each, respectively. The air on the warm side of the specimen in the winter weathering test was conditioned to 70° F and 60 per cent relative humidity, and to -10° F on the cold side. The summer weathering test specimen was exposed to prevailing room air conditions with only the roofing exposed to solar radiation.

During the initial 30-day period of winter weathering for Specimen A, no visible evidence of deterioration occurred. The initial 30-day period of summer weathering for Specimen B produced slight deterioration and pressure rise similar to that which occurred for one of the specimens previously subjected to summer weathering. On the first day following interchange of the specimens, whereby Specimen A was exposed to summer weathering and Specimen B to winter weathering cycles, small blisters similar in appearance to those previously observed appeared on the surface of Specimen A and bulging of the roofing occurred during a period of heat application. No change occurred in Specimen B. The height of the bulges above the surface of the roof during this period reached approximately $\frac{1}{2}$ inch. The bulges were of an elongated shape approximately 2 inches wide by 12 inches long, and resembled on a small scale structural blisters found in actual roof failures. During the following cycles of heating and cooling, the blisters gradually receded. At the end of the 30-day summer weathering period the blisters were barely noticeable.

Upon completion of the 60-day test, the roof specimens were disassembled and visually examined with the following results:

Specimen A: (Specimen exposed to a final cycle of summer weathering.) Gas pockets beneath the raised roofing surface occurred between the under surface of the roofing and the top surface of the insulation board. The bottom layer of insulation was noticeably damp. There was no visual evidence of deterioration of either the roofing or the vapor seal course.

Specimen B: (Specimen exposed to a final cycle of winter weathering.) As the specimen had been permitted to remain in warm room air prior to inspection, water instead of ice was found condensed on the under surface of the roofing. The top layer of the insulating board was noticeably damp on the surface adjacent to the roof, and the remaining layers of insulation appeared to be dry.

There was no visual evidence of deterioration of the vapor seal course. The roofing from both specimens was subjected to vapor permeability tests and the results, presented in Table B-VI, show an extremely low permeability in each case. Thus it is apparent that exposure of roofing to accelerated summer weathering conditions has a negligible effect upon its sealing qualities.

TABLE B-VI
Vapor Permeability of Roofing Specimens Subjected to
Combined Winter and Summer Weathering

Spec. No.	Specification	Vapor Barrier and Moisture Content of Insulation	Vapor Permeability Gr/sq ft/hr/in. Hg
A	3 ply asphalt	Insulation 14.0 per cent M. C. vapor seal course	0.14
B	3 ply asphalt	Insulation 14.0 per cent M. C. vapor seal course	0.12

B-7. EFFECT OF AGING ON THE VAPOR PERMEABILITY OF VAPOR SEAL COURSES

The vapor seal courses used in the weathering tests were subjected to vapor permeability tests to determine whether or not any evidence of deterioration had taken place. The results of these tests are presented in Table B-VII and show that the vapor permeability rates varied from .18 to .35, an indication that no definite increase of any magnitude had occurred for any of the specimens. The vapor permeability rates for the vapor seal courses used on the combined summer and winter weathering tests indicated a slightly greater permeability than did vapor seal courses subjected to the other two test conditions. It is problematical as to whether this is significant as an indication of the possible breakdown of a vapor seal course because of aging, as only a limited number of tests were conducted. In any event, however, the increase in rate due to weathering imposed in these tests is insignificant.

TABLE B-VII

Vapor Permeability of Vapor Seal Course Specimens Contained in the Different Roof Structures Subjected to Various Weathering Conditions

Specimen No.	Specifications	Moisture Content of Insulation, per cent	Vapor Permeability Gr/sq ft/hr/in. Hg
		Winter Weathering	
C	Panel 4-V	17.3	0.24
F	Panel 4-V	4.7	0.20
		Summer Weathering	
1	Panel 1-V	5	0.18
2	Panel 1-V	18	0.22
		Combined Winter and Summer Weathering	
A	Panel 1-V	14	0.35
B	Panel 1-V	14	0.30

B-8. EFFECT OF CONCRETE DECKS ON THE PERMEABILITY OF VAPOR SEAL COURSES

In the construction of the roofing vapor seal courses used in previous tests, the undercoat was applied after the membrane had been removed from the roof deck and reversed to expose the underside. This procedure was followed to allow easy removal of the specimen from the deck on which it was constructed. However, it was suspected that in actual construction partial absorption of the undercoat by the concrete, together with partial absorption by the roof insulation, might result in a decrease in efficiency of the vapor seal. In order to determine this effect, three specimens, consisting of a standard type of vapor seal course mopped to a 1-inch thick concrete slab and covered with ½-inch insulating board, were constructed in the laboratory. A permeable 1:2:4 concrete mix was used to minimize the resistance to vapor transmission of this specimen component. The concrete slabs were cured for a period of 30 days prior to application of the vapor seal course. The vapor seal course was constructed according to the specification for Panel 2-V, described pre-

viously in Appendix B-2. Laboratory control of conditions permitted rigid adherence to this specification. A ½-inch layer of insulating board imbedded in the hot surface mopping of the vapor seal course completed the specimen construction.

The three specimens were mounted in the special frames with the insulation board exposed on the warm side and subjected to test in the vapor permeability test apparatus. The specimens remained in test for an 85-day period, of which 70 days were required for the concrete slab to reach an equilibrium moisture content. The results of the tests showed vapor permeability of the three specimens to be 0.36, 0.26 and 0.37, or an average of 0.33 grain per square foot per hour per inch mercury. These low permeability rates indicate that proper mopping of accepted vapor seal courses has little effect on their resistance to vapor transmission.

B-9. MOISTURE MIGRATION WITHIN INSULATED ROOFS

A study was made of the behavior of moisture, both deposited and transmitted, within insulated roof specimens under the following conditions:

1. Specimens subjected to vapor transmission tests with the warm side air conditions stabilized at 70° F and 60 per cent relative humidity and the cold side air temperature controlled at -10° F
2. Specimens subjected to winter weathering tests with the warm side air conditions stabilized at 70° F and 60 per cent relative humidity and the weatherside subjected to a winter weathering cycle
3. Specimens subjected to combined winter and summer weathering conditions.

Vapor Transmission Specimens

Vapor transmission tests were conducted in the roof test apparatus, described in Appendix A-2, and on roof assemblies having different warm side permeabilities, to study the effect of various rates of moisture accumulation in roof specimens. Since it was necessary to install barriers of different known permeabilities on the warm side of the various roof specimens, preliminary vapor permeability tests were conducted on a variety of vapor barriers in the special small panel test apparatus. The vapor resistances of both the membranes and the membranes plus 2 inches of fiberboard insulation were obtained. The barriers selected, together with transmission rates indicating their individual resistance to vapor passage, are listed as follows:

Red rosin paper	14.35 gr/sq ft/hr/in. Hg
50-pound surface-treated kraft paper.....	3.93 gr/sq ft/hr/in. Hg
70-pound surface-treated kraft paper.....	3.22 gr/sq ft/hr/in. Hg
Saturated rag felt	2.60 gr/sq ft/hr/in. Hg
Vapor seal course	0.00 gr/sq ft/hr/in. Hg

The permeability of the combined vapor membrane and insulation board is shown in Table B-VIII.

Five roof specimens containing the different barriers listed above and one specimen having no barrier were subjected to test for a period of 49 days. At the conclusion of the test the specimens were disassembled and visually inspected. The results of this inspection are shown in Table B-VIII. It should be noted that the lower vapor permeability rates for

TABLE B-VIII
Vapor Permeability Rates and Frost Accumulation in Roof Assembly Specimens

Spec. No.	Type of Barrier	Vapor Permeability Gr/sq ft/hr/in. Hg		Visual Inspection
		Membrane only	Membrane and insulation	
F	Roofing vapor seal course	0.0	0.0	No frost on roofing or in insulation
D	15-pound asphalt-saturated felt	2.60	0.25	Trace of frost on under surface of roofing, none in insulation
B	70-pound surface-treated kraft paper	3.22	1.03	Thin film of frost on under surface of roofing felt, none in insulation
C	50-pound surface-treated kraft paper	3.93	1.18	Layer of frost approximately 1/32-inch thick on the under surface of roofing felt, none in insulation
E	Red rosin paper	14.35	3.30	Layer of frost 1/16 to 3/32-inch thick on the under surface of roofing felt; frost between insulating board laminations on cold side
A	No vapor barrier	3.50	Layer of frost approximately 3/32-inch thick on the under surface of roofing felt; frost between insulating board laminations on cold side

the combined vapor membrane and the 2-inch insulation board are due to the added resistance of the insulation. For poor vapor membranes having a high rate of vapor permeability, the added resistance of the insulation is more effective in reducing the over-all permeability rate than for vapor membranes having low vapor permeability rates. The inspection showed that no frost or moisture was visible within roof Specimen F, which contained a vapor seal course on the warm side. For specimens B, C, and D, which contained barriers having progressively higher transmission rates, frost was found in varying degrees underneath the roof-

ing, but none was found in the insulation. For Specimen E, containing a barrier having low resistance to vapor transmission, and Specimen A, having no vapor barrier, frost was found in both the insulation and underneath the roofing. The results of this inspection indicate that there is a direct relationship between the vapor permeability of the barrier used and the amount of moisture or frost which accumulates within the roof structure.

After the visual examination was completed, samples were cut from each of the ½-inch layers of fiberboard contained in the different specimens, and the moisture content of each layer was determined. The moisture contained in each layer of the six specimens at the end of the test is shown in Table B-IX. The original moisture content of all insulation board was 1.9 per cent.

TABLE B-IX
The Effect of Vapor Transmission on Moisture Distribution
Within Insulated* Roof Decks

Spec. No.	Vapor Barrier	Insulation Position†	Moisture Content of Insulation (per cent by weight)
A	None	1	62.06
A	None	2	51.91
A	None	3	47.80
A	None	4	10.40
			Average 41.
E	Red rosin paper (14.35 grs)§	1	61.40
E	"	2	49.80
E	"	3	31.53
E	"	4	12.67
			Average 39.
B	70-pound surface-treated kraft paper (3.22 grs)	1	12.93
B	"	2	8.40
B	"	3	5.74
B	"	4	4.22
			Average 7.8
C	50-pound surface-treated kraft paper (3.93 grs)	1	11.96
C	"	2	6.63
C	"	3	4.65
C	"	4	3.27
			Average 6.6
D	Asphalt-saturated rag felt (2.60 grs)	1	7.23
D	"	2	4.50
D	"	3	2.70
D	"	4	2.03
			Average 4.1
F	Roofing vapor seal course (0.0 grs)	1	3.30
F	"	2	1.94
F	"	3	1.51
F	"	4	0.87
			Average 1.92

* Moisture content of insulation before test was 1.9 per cent.

† Four ½-inch insulation boards positioned from cold to warm side of specimen to provide 2-inch thickness.

§ Values in parentheses are permeability rates of vapor barriers in grains per square foot per hour per inch mercury.

The tabulated results show that a definite moisture gradient exists in the insulation board and that the relative distribution of moisture is similar in all specimens. Regardless of the amount of moisture which accumulates in each specimen, the insulation board adjacent to the cold side contained the most moisture, and the moisture content of the insulation decreased toward the warm side. Increase in average moisture content from 1.9 per cent to the values shown for each roof specimen in Table B-IX indicates, as did the visual examination, that there is a direct relationship between the moisture accumulation within the roof assemblies and the permeability of the vapor seal.

Winter Weathering Specimens

The effect of winter weathering conditions on the migration and redistribution of moisture was studied during the simulated winter weathering tests of roofing described in Appendix B-4. Three roof specimens containing insulation board at 4.7 per cent moisture content were constructed with different warm side vapor permeabilities through the use of the vapor seals listed below:

Vapor seal course	0.00 gr/sq ft/hr/in. Hg
70-pound surface-treated kraft paper.....	3.93 gr/sq ft/hr/in. Hg
None

Three additional specimens were prepared which were identical to those above, except that they contained insulation having a moisture content in excess of 17 per cent. These specimens permitted the independent study of the migration and redistribution of moisture which is present in the insulation and which is transmitted into roof specimens when subjected to winter weathering.

After the tests were completed, the specimens were disassembled and the final moisture content was determined for each ½-inch layer of insulation board in the six specimens. These moisture contents, as well as the average original and average final moisture contents of the insulation, are shown in Table B-X. The results show that a definite moisture gradient existed in the insulation of each specimen with the high moisture area adjacent to the cold side of the specimen. This gradient indicates that a redistribution of moisture occurs from the warm side regardless of whether the moisture is transmitted or trapped, in large or small quantities, in the roof assemblies subjected to winter weathering conditions. The tabulated average original and average final moisture contents for the different specimens indicate, as did the previous vapor transmission tests, that a direct relationship exists between the permeability of the vapor barrier and the total amount of moisture accumulated. The table shows that the specimens containing insulation at a high moisture content gained less moisture than the corresponding specimens constructed with insulation having low moisture content. These data appear reasonable since the wet insulation would exert an independent vapor pressure which would oppose the vapor pressure differential existing across the specimen.

TABLE B-X
Moisture Distribution Within Insulated Roofs Subjected to Winter Weathering Conditions

Spec. No.	Type of Barrier	Insulation Position ^a	Moisture Content of Insulation, per cent	
			Before test	After test
A	None	1		101.9
A	None	2		71.8
A	None	3		88.9
A	None	4		41.7
			Average	21.1
B	50-pound kraft paper specially surface treated (3.93 grs) [†]	1		62.5
B	"	2		17.5
B	"	3		11.4
B	"	4		7.7
			Average	17.8
C	Vapor seal course (0.0 grs)	1		46.1
C	"	2		13.8
C	"	3		6.7
C	"	4		6.3
			Average	17.3
D	None	1		85.8
D	None	2		66.6
D	None	3		80.5
D	None	4		27.4
			Average	4.7
E	50-pound kraft paper specially surface treated (3.93 grs)	1		35.3
E	"	2		11.6
E	"	3		8.2
E	"	4		7.4
			Average	4.7
F	Vapor seal course (0.0 grs)	1		10.0
F	"	2		5.9
F	"	3		4.4
F	"	4		3.9
			Average	4.7
				6.0

^a Four ½-inch insulation boards positioned from cold to warm side of specimen to provide 2-inch thickness.

[†] Values in parentheses are permeability rates of vapor barriers in grains/sq ft/hr/in. Hg.

Combined Summer and Winter Weathering Specimens

A study was made of the moisture migration and redistribution which occurred during the combined winter and summer weathering tests described in Appendix B-6. In review, two identical roof specimens, each containing 10-year type built-up roofing, two inches of fiberboard insulation having a moisture content of 14 per cent and a vapor seal course, were tested. One was subjected to winter weathering and the other to summer weathering. At the end of a 30-day period, the specimens were interchanged, each being subjected to the opposite weathering cycle for another 30-day period.

Moisture contents determined for the individual layers in each specimen are shown in Table B-XI. A graphical presentation of this data is shown in Figure B-9. The moisture gradient through Specimen A is approximately reversed from that of Specimen B as would be expected from the comparative temperature gradients. The average initial and final moisture contents indicate a loss of moisture in the insulation in Specimen A. This loss probably occurred during the final 30-day period of summer weathering and it is possible that the slight increase in permeability of the vapor seal course in this specimen, due to aging, permitted this loss of moisture.

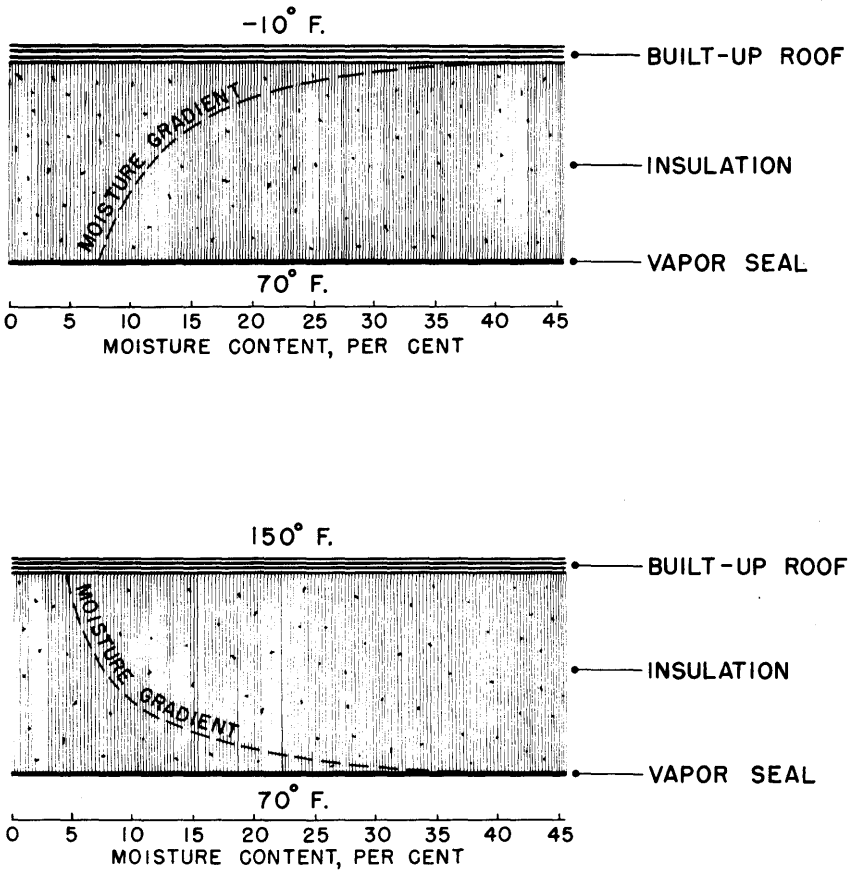

Figure B-9. Effect of Roof Surface Temperature on the Moisture Gradient Within Insulated Roof Decks

TABLE B-XI
**Moisture Content of Insulation in Specimens Subjected to Winter-Summer
 Weather Test**

Spec. No.	Insulation Board Layer ^a	Moisture Content, Per Cent by Weight	
		Original	Final
A	1		5.0
	2		6.5
	3		9.1
	4		20.5
	Average	14.0	10.3
B	1		23.9
	2		13.6
	3		10.4
	4		8.1
	Average	14.0	14.0

^a Layer 1 is adjacent to roofing.

APPENDIX C

SPECIFICATIONS FOR APPLYING STRUCTURAL¹ INSULATING BOARD OVER FLAT ROOF DECKS UNDER BUILT-UP ROOFING

Structural insulating board used as roof insulation shall be a rigid, fiberboard conforming to Federal Specification LLL-F-321b, Class C and Commercial Standard CS42-49. It shall be of such rigidity that composition roofing can be safely applied to its top surface and shall be approved by the roofing manufacturer and the roofing contractor as satisfactory for this purpose.

Insulating board roof insulation can be obtained in 23 inch by 47 inch and 24 inch by 48 inch sizes, and in thicknesses of $\frac{1}{2}$ inch, 1 inch, $1\frac{1}{2}$ inches, and 2 inches. The edges are square except on thicknesses greater than $\frac{1}{2}$ inch, in which case the edges may be either square or offset (shiplap).

This specification covers the application of structural insulating board over the following types of roof decks: wood, concrete, gypsum, unit tile and steel.

1. STORAGE OF MATERIALS—PROTECTION AGAINST MOISTURE

- 1a. **Insulation.** The roof insulation shall be kept dry before, during, and following application and shall be protected at all times against inclement weather.
- 1b. **Roofing Felts.** All felts shall be kept dry and shall be protected at all times against inclement weather.
- 1c. **Roof Deck.** Previous to starting work, the general contractor and/or owner shall meet on the roof with all interested parties having to do with the work, to jointly accept the construction of the roof and the condition of the roof deck before any insulation or roofing is applied.

2. GENERAL INSTRUCTIONS

- 2a. **Insulation.** Only as much insulating board shall be laid over the roof area as can be covered by the finished roofing in one day. At the end of each day's work, or at the time of any work stoppage, water cut-offs (see 2d) shall be applied and mopped solidly over the exposed edge of the insulation.
- 2b. **Staggered Joints and Adjoining Boards.** Boards shall be laid in parallel courses with end joints of each course breaking with those of adjoining courses. Adjoining edges of the boards shall be brought to a moderate contact, but shall not be forced into place.
- 2c. **Two-Layer Construction.** Where insulation is laid in two layers, the boards of the second layer shall be laid parallel with those of the first layer, and the joints of the second layer shall break joints with those of the first layer.

¹ As recommended by the Insulation Board Institute, April, 1952.

- 2d. **Water Cut-Offs (Path Strips).** At first full insulating board joint back from skylight or monitor sash, parapet walls, penthouses and at borders, etc., provide a cut-off strip of roofing felt. This cut-off shall consist of strips of saturated roofing felt approximately 12 inches wide laid by *solidly mopping* one-half of the strip to the roof in hot bitumen and then folding the remainder of the strip over the insulation and mopping to the top surface of the insulation. When shiplapped roof insulation is used, the shiplap shall be removed at the cut-off. Beyond the first cut-off on inclines of less than 3 inches to the foot, the roof insulation may be further subdivided by means of cut-offs every 30 feet in one or both directions.
- 2e. **Vertical Surfaces.** Where the roof meets vertical surfaces, such as parapets, penthouses, etc., the boards shall be cut in a neat, workmanlike manner to allow a clearance of not over $\frac{1}{2}$ inch. All edges of insulation at vertical surfaces and roof edges shall be sealed by means of cut-offs or by solidly mopping at least 6 inches of the underlying vapor barrier course over the insulation. Cant strips shall be provided at all intersections of roof surfaces and vertical walls, parapets and curbs, and shall be set on top of roof insulation and securely fastened in place by nailing or hot mopping. Cant strips shall not be nailed to a deck where a vapor proofing course is used.
- A four-inch wide wood nailing strip equal in thickness to the insulation shall be provided when insulation does not end against a vertical stop.
- 2f. **Vapor Barriers.** Vapor barriers shall be used on decks of heated buildings wherever the average January temperature is below 45° F. Vapor barriers shall be used on all buildings in which excessive moisture conditions prevail, such as textile mills, laundries, canning factories, creameries, breweries, and many other such processing plants.
- The vapor barrier shall consist of two plies of No. 15 felt or on wood decks a vapor barrier may consist of a base sheet of 45-pound per square prepared asphalt roofing having one side coated. Wrap vapor barrier around edge of insulation and mop back 6 inches at walls and other vertical projections.
- Care shall be taken to prevent tears, breaks or ruptures of any kind which might interfere with the effectiveness of the vapor barrier.
- 2g. **Bitumen and Felts.** Coal tar pitch (meeting Federal Specification R-P-381-Type 1) or asphalt (meeting Federal Specification SS-A-666) products may be used. In order to secure a strong bond and proper thickness of mopping, the temperature of asphalt shall be 375°-400° F, that of pitch 350°-375° F. Asphalt impregnated felts shall be used with asphalt mopping, tarred felts with coal tar pitch mopping.
- All roofing felts shall be solidly mopped in place and laid without wrinkles or buckles. They shall be thoroughly broomed down so as to obtain positive adhesion and elimination of air bubbles between each of the surfaces or plies and at edges.

3. APPLICATION OVER WOOD ROOF DECKS

- 3a. **Roof Deck.** The surface of the roof deck shall be free from dirt and loose material and shall be thoroughly dry. All loose or springy boards shall be properly nailed before insulation is laid.
- 3b. **Nails.** Use large-headed galvanized nails (not less than 7/16-inch head) of sufficient length to pass through the insulation and penetrate into the roof boards at least $\frac{3}{4}$ inch. Nails should not pass through roof deck.
- 3c. **Coal Tar Pitch Application.** Where coal tar pitch is used, the wood deck shall be covered with red rosin sheathing paper to prevent bitumen from dripping through. The sheathing paper need be nailed only as often as necessary to hold it in place and be kept free from wrinkles or buckles until covered by the insulation or vapor barrier.
- 3d. **Vapor Barrier.** Vapor barrier shall be used in all cases under conditions specified in Paragraph 2f.
- (a) Mop the roof deck with a coat of hot asphalt. Over the mopping, while hot, lay two plies, lapped half of No. 15 felt with solid mopping between each ply. Wrap vapor barrier around edges of insulation and mop back 6 inches at walls and other vertical projections. Turn back top ply, solidly mop bottom and top laps with hot bitumen for solid cementing. Nail the back edge of each sheet with tin-capped galvanized barbed roofing nails spaced 12 inches on center or
- (b) Lay a base sheet of 45-pound prepared asphalt roofing, laying coated side down, lapped up to 4 inches with laps nailed with galvanized barbed roofing nails spaced 2 inches on center with all laps solidly cemented.
- 3e. **Application of Insulation.** The roof insulation shall be laid at right angles to the roof boarding. The insulation may be applied to the wood roof deck either by nailing as in the Paragraph 3e (1), or where a vapor barrier is required, by mopping as in Paragraph 3e (2). Edges of insulation shall be in moderate contact and shall not be forced in place. Where insulation meets vertical surfaces, cut to allow not over $\frac{1}{2}$ inch clearance.
- (1). **Application by Nailing Insulation.** Space nails 12 inches apart. Each board shall be secured in place by nailing each edge and staggered along the longitudinal center line. Drive nails slightly below surface of insulating board.
- If two layers of insulation are used, nailing shall also be through the second or top layer, using nails of sufficient length to penetrate into the wood deck at least $\frac{3}{4}$ inch, or the second layer may be solidly mopped to the first layer.
- (2). **Application by Mopping Insulation.** *Solidly mop* the exposed vapor barrier felt liberally with hot bitumen. Only sufficient area to provide complete embedment of each insulating board shall be mopped at a time. Embed each board firmly in the *solid mopping* of bitumen. Where two layers of insulating board are to be applied, *solidly mop* the exposed surface of the first layer liberally with hot bitumen. Only

sufficient area to provide complete embedment of each board shall be mopped at a time. Embed each board of the second layer firmly in the *solid mopping* of bitumen.

4. APPLICATION OVER CONCRETE, GYPSUM AND UNIT TILE

- 4a. **Roof Deck.** The surface of the roof deck shall be reasonably smooth without depressions, free from dirt and loose materials, thoroughly dry and pitched to drain. Where deck is of precast cement slabs, gypsum plank, book tile or similar units, the joints shall be properly grouted or pointed up.
- 4b. **Priming the Deck.** If coal tar pitch is used, no primer is necessary. If asphalt is used, prime the deck with asphalt primer. Use a liberal coating of primer over gypsum decks.
- 4c. **Vapor Barrier.** A vapor barrier shall be used in all cases on concrete and poured gypsum decks.

(1). **Over Poured Concrete.** Where the deck is of poured concrete construction the mopping shall be continuous. Over the hot mopping lay two plies of No. 15 felt lapped half. Each ply shall be solidly mopped to the deck and also between plies, followed by thorough brooming down of felts to eliminate air pockets and to obtain positive adhesion between each of the surfaces or plies of felts.

Apply insulation as specified in Paragraph 4d.

(2). **Over Poured Gypsum.** Where the deck is of poured gypsum construction, channel mop with continuous moppings of hot bitumen approximately 2 feet wide with channel spacings approximately 6 inches wide between moppings. Over the hot mopping lay two plies of No. 15 felt lapped half and solidly mopped between plies, followed by a thorough brooming down of felts to eliminate air pockets and to obtain positive adhesion between each of the surfaces or plies of felts.

Apply insulation as specified in Paragraph 4d.

(3). Over precast cement slabs, gypsum plank, book or similar units, apply insulation board vapor barrier directly to deck by spot or strip or channel mopping, keeping the mopping back approximately 4 inches from joints when using pitch. If steep asphalt is used it may be solidly mopped.

Where a vapor barrier is used, apply the insulation in accordance with Paragraph 4d.

- 4d. **Application of Insulation.** Over the vapor barrier embed each board firmly in a solid mopping of bitumen. Only sufficient area to provide complete embedment of each board shall be mopped at a time. Where two layers of insulating board are to be used, *solidly mop* the exposed surface of the first layer liberally with hot bitumen and embed each board in a *solid mopping* of bitumen.
- 4e. **Steep Roof Decks.** On steep roof decks having a slope of 3 inches or more per foot, provision shall be made for additionally securing the roof insulation by nailing or other mechanical fastening. Where the roof deck cannot be used as a nailing base, embed

nailing strips on not more than 3-foot centers in the surface of the deck parallel to the incline of the roof. Also, use steep roofing pitch or steep roofing asphalt.

5. APPLICATION OVER STEEL ROOF DECKS

5a. **Roof Deck.** The roof deck shall be smooth, clean and free from rust and grease (and primed if not shop coated) and shall be made rigid.

Note 1: On fluted decks a minimum of 1-inch insulation shall be used. On extremely wide gaps consult manufacturers.

Note 2: Pitch shall not be used for bonding felt or insulation to steel decks.

5b. **Vapor Barrier.** Vapor barrier shall be used in all cases under the conditions specified in Paragraph 2f. Mop the roof deck with a coat of hot asphalt. Over the mopping, while hot, lay two plies, lapped half of No. 15 felt with solid mopping between each ply. Wrap vapor barrier around edges of insulation and mop back 6 inches at walls and other vertical projections.

5c. **Application of Insulation.** *Solidly mop* the insulation to the deck or vapor barrier with a liberal coat of hot asphalt. Only sufficient area to provide complete embedment of each board shall be mopped at a time. Embed each board firmly in the hot asphalt. Where two layers of insulating board are to be used, *solidly mop* the exposed surface of the first layer liberally with hot asphalt. Embed each board of the second layer firmly in the mopping.

5d. **Steep Roof Decks.** Where insulating board is applied over roof decks having a slope of 1 inch or more per foot, each board along the top shall be secured to the steel deck with mechanical fasteners or other devices supplied by the deck manufacturer and which do not penetrate the deck.

The Engineering Experiment Station of the University of Minnesota was established by an act of the Board of Regents on December 13, 1921.

The purpose of the Station is to advance research and graduate study in the Institute of Technology, to conduct scientific and industrial investigations, and to cooperate with governmental bodies, technical societies, associations, industries, or public utilities in the solution of technical problems. The results of scientific investigations will be published in the form of bulletins and technical papers. Information which is of general interest and yet not the result of original research may be distributed in the form of circulars.

For a complete list of publications or other information concerning the work of the Station, address the Director of the Engineering Experiment Station.

Bulletins Available

12. Thermal Conductivity of Building Materials, by F. B. Rowley and A. B. Algren. x + 134 pages, 109 illustrations. 1937. \$1.50. (Purchased through University Press.)
14. Square Sections of Reinforced Concrete under Thrust and Nonsymmetrical Bending, by Paul Andersen. vi + 42 pages, 8 figures, 23 diagrams. 1939.
15. Laboratory Studies of Asphalt Cements, by F. C. Lang and T. W. Thomas. x + 96 pages, 43 illustrations. 1939.
16. Factors Affecting the Performance and Rating of Air Filters, by F. B. Rowley and R. C. Jordan. viii + 54 pages, 21 illustrations. 1939.
18. Condensation of Moisture and Its Relation to Building Construction and Operation, by F. B. Rowley, A. B. Algren, and C. E. Lund. vi + 69 pages, 28 illustrations. 1941.
19. Pulp, Paper, and Insulation Mill Waste Analysis, by F. B. Rowley, R. C. Jordan, R. M. Olson, and R. F. Huettl, vi + 55 pages, 34 illustrations. 1942.
20. Conservation of Fuel, by F. B. Rowley, R. C. Jordan, and C. E. Lund. vi + 61 pages, 22 illustrations, 17 tables. 1943.
21. Aids to Technical Writing, by R. C. Jordan and M. J. Edwards. viii + 112 pages, 60 illustrations, 13 tables. May, 1944.
22. Vapor Transmission Analysis of Structural Insulating Board, by F. B. Rowley and C. E. Lund. vi + 71 pages, 24 illustrations. 16 tables. October, 1944.
24. Factors Affecting Heat Transmission through Insulated Walls, by F. B. Rowley and C. E. Lund. iv + 25 pages, 8 illustrations, 8 tables. April, 1946.
25. Vapor Resistant Coatings for Structural Insulating Board, by F. B. Rowley, M. H. LaJoy, and E. T. Erickson. vi + 31 pages, 9 illustrations, 10 tables. September, 1946.
26. Moisture and Temperature Control in Buildings Utilizing Structural Insulating Board, by F. B. Rowley, M. H. LaJoy, and E. T. Erickson. vi + 38 pages, 16 illustrations, 8 tables. July, 1947.
27. Water Permeability of Structural Clay Tile Facing Walls, by J. A. Wise. iv + 32 pages, 26 illustrations, 4 tables. August, 1948.
28. Thermal Properties of Soil, by M. S. Kersten. xiv + 227 pages, 138 illustrations, 15 tables, 5 plates. June, 1949.
29. Proceedings of the Symposium on Engineering Research, edited by C. E. Lund. x + 110 pages. August, 1949.
30. Some Causes of Paint Peeling, by F. B. Rowley and M. H. LaJoy. vi + 34 pages, 23 illustrations, 11 tables. September, 1949.
31. Determination of Load Distribution on a Beam from Measurements on Its Deflected Form, by P. Andersen and S. Mukhopadhyay. x + 56 pages, 16 illustrations, 13 tables. January, 1950.
32. Determination of Particle Size Distribution—Apparatus and Technique for Flour Mill Dust, by K. T. Whitby. viii + 39 pages, 27 illustrations, 1 table. January, 1950.
33. A Modified Plastic Theory of Reinforced Concrete, by Paul Andersen and Hsa-Ni Lee. vi + 40 pages, 15 illustrations, 1 table. April 16, 1951.

Technical Papers Available

1. Condensation within Walls, by F. B. Rowley, A. B. Algren, and C. E. Lund. 12 pages. January, 1938.
32. Construction and Operation of a 15-Inch Cupola, by F. Holtby. 4 pages. August, 1941.
42. Abnormal Currents in Distribution Transformers Due to Lightning, by J. M. Bryant and M. Newman. 5 pages. September, 1942.
46. Discoloration Method of Rating Air Filter, by F. B. Rowley and R. C. Jordan. 10 pages. September, 1943.
48. Valve Guide Leakage in an Automotive Engine, by M. A. Lindeman and B. J. Robertson. 22 pages. May, 1944.
52. Carbon Dioxide Variation in a Vented Stack, by M. H. LaJoy. 27 pages. May, 1945.
53. Thermal Conductivity of Insulating Material at Low Mean Temperatures, by F. B. Rowley, R. C. Jordan, and R. M. Lander. 6 pages. December, 1945.

56. Calculation of Bearing Capacities of Footings by Circular Arcs, by Paul Andersen. 3 pages. June, 1946.
60. Comfort Reactions of 275 Workmen during Occupancy of Air-Conditioned Offices, by F. B. Rowley, R. C. Jordan, and W. E. Snyder. 4 pages. June, 1947.
62. A Statistical Analysis of Water Works Data for 1945, by G. J. Schroepfer, A. S. Johnson, H. F. Seidel, and M. B. Al-Hakim. 32 pages. October, 1948.
63. Theory and Use of Capillary Tube Expansion Device, by M. M. Bolstad and R. C. Jordan. 6 pages. December, 1948.
65. Impact Strength Testing Machine, by F. B. Rowley and M. H. LaJoy. 16 pages. June, 1949.
66. Ground Temperatures as Affected by Weather Conditions, by A. B. Algren. 6 pages. June, 1949.
67. Theory and Use of Capillary Tube Expansion Device, Part II, Nonadiabatic Flow, by M. M. Bolstad and R. C. Jordan. 7 pages. June, 1949.
68. Thermal Conductivity of Soils, by M. S. Kersten. 19 pages. July, 1949.
69. Specific Heat Tests on Soils, by M. S. Kersten. 5 pages. May, 1949.
71. Continuous Flow Stirred-Tank Reactor Systems. I. Design Equations for Homogeneous Liquid Phase Reactions, by J. W. Eldridge and E. L. Piret. 10 pages. June, 1950.
72. Resistance Gradients through Viscous Coated Air Filters, by F. B. Rowley and R. C. Jordan. 8 pages. December, 1949.
73. Crushing of Single Particles of Crystalline Quartz, by J. W. Axelson and E. L. Piret. 6 pages. April, 1950.
74. Continuous Flow Stirred Tank Reactor Systems. Development of Transient Equations, by D. R. Mason and E. L. Piret. 9 pages. May, 1950.
75. Hot Wire Anemometry, by G. B. Middlebrook and E. L. Piret. 3 pages. August, 1950.
76. Snow, Ice, and Permafrost, by R. C. Jordan and H. T. Mantis. 5 pages. October, 1950.
77. Bathymetric Chart of Lake Michigan, by K. O. Emery. 16 pages. April, 1951.
78. Effect of Continuously Controlled pH on Lactic Acid Fermentation, by L. L. Kempe, H. O. Halvorson, and E. L. Piret. 6 pages. September, 1950.
79. Lactic Acid Fermentation Rate, by R. K. Finn, H. O. Halvorson, and E. L. Piret. 5 pages. September, 1950.
80. Continuous Stirred Tank Reactor Systems, by D. R. Mason and E. L. Piret. 10 pages. May, 1951.
81. Factors Affecting Built-up Roofs, by C. E. Lund and R. M. Granum. 11 pages. October, 1951.
82. Continuous Flow Stirred Tank Reactor Systems—Agitation Requirements, by R. W. MacDonald and E. L. Piret. 8 pages. July, 1951.
84. The Effect of Temperature on the Bearing Values of Frozen Soils, by A. E. Cox and M. S. Kersten. 8 pages. July, 1951.
85. Thermodynamic Properties of Air, Nitrogen and Oxygen as Imperfect Gases, by N. A. Hall and W. E. Ibele. 157 pages. June, 1952.
86. Configuration and Structure of Cellulose Xanthate, by Chian-Yuang Chen, R. E. Montonna, and C. S. Grove, Jr. 8 pages. September, 1951.
87. Damping, Elasticity, and Fatigue Properties of Temperature-Resistant Materials, by B. J. Lazan and L. J. Demer. 36 pages. October, 1951.
88. Effect of Particle Shape on Porosity and Surface Area of Trickling Filter Media, by G. J. Schroepfer. 11 pages. November, 1951.
89. Diffusion Rates in Extraction of Porous Solids, by E. L. Piret, R. A. Evel, K. T. Kiang, and W. P. Armstrong. 20 pages. December, 1951.
90. Gas Is an Important Factor in the Thermal Conductivity of Most Insulating Materials, by F. B. Rowley, R. C. Jordan, C. E. Lund, and R. M. Lander. 7 pages. December, 1951.
91. Determination of Fair Sewage Service Charges for Industrial Wastes, by G. J. Schroepfer. 22 pages. December, 1951.

Circulars Available

2. Wartime Refrigeration Training at the University of Minnesota, by R. C. Jordan and C. E. Lund. 3 pages. September, 1944.
3. Five-Year Mechanical Engineering Curriculum, by R. C. Jordan. 5 pages. January, 1947.
5. Instrumentation and Automatic Control Course for Mechanical Engineers, by M. H. LaJoy. 2 pages. April, 1951.
6. Research and You, by R. E. Montonna. 3 pages. March, 1951.

