

UNIVERSITY OF MINNESOTA  
ST. ANTHONY FALLS HYDRAULIC LABORATORY

Project Report No. 303

PHYSICAL MODEL STUDY  
OF THE UPPER INTAKE - OUTLET STRUCTURE  
ROCKY MOUNTAIN PROJECT

by

Richard L. Voigt, Jr.

and

Joseph M. Wetzell

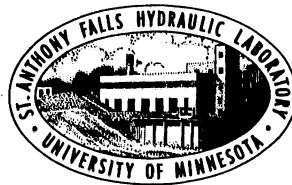

Prepared for

HARZA ENGINEERING COMPANY  
Chicago, Illinois

January 1990

Minneapolis, Minnesota



## TABLE OF CONTENTS

	<u>Page No.</u>
Acknowledgements	ii
List of Figures	iii
List of Photos	v
I. Introduction	1
II. Model Description	2
III. Model Observations	5
IV. Conclusions	13

## ACKNOWLEDGEMENTS

The authors would like to thank the following people for their input during the study: Messrs. Bob Ivarson and Nick Hernandez of Harza and Messrs. Ben Trammell, Jr., Dale Murphy, and Gil Taylor and Gilbert Lindsay of Oglethorpe Power Corporation. Special thanks go to Messrs. Wayne Coleman and Jim Borg of Harza, without whose model observations and general comments, the study would have been much more difficult.

The authors would like to acknowledge Dr. John Killen, Messrs. Jai Jeffrey, Karl Wikstrom, Bashar Sinokrot, Sanjiv Kumar Sinha, and Ms. Petra Vesters, whose assistance with data assimilation and general model operation made completion of the study possible. The authors greatly appreciate the efforts of Mr. Aaron Gimbel and Ms. Lulu Krogh in preparing figures, typing and assembling the report.

## List of Figures

- Figure 1 Overall Upper Reservoir Layout in Model Basin.
- Figure 2 Dam Sidewall Porosity Zones.
- Figure 3 Initial Upper Reservoir Bed Topography.
- Figure 4 Pressure Tap Locations - Elevation.
- Figure 5 Pressure Tap Locations in Roof - Plan.
- Figure 6 Schematic of Model Piping System.
- Figure 7 Suspended Cone Modification to Roof.
- Figure 8 Modification to Upper Reservoir Bed Topography.
- Figure 9 Intake Velocity Measurements Turbine Mode,  
Reservoir Elev. 1392,  $Q = 18,000$  cfs.
- Figure 10 Intake Velocity Measurements Turbine Mode,  
Reservoir Elev. 1392,  $Q = 18,000$  cfs.
- Figure 11 Intake Velocity Measurements Turbine Mode,  
Reservoir Elev. 1366,  $Q = 18,000$  cfs.
- Figure 12 Intake Velocity Measurements Turbine Mode,  
Reservoir Elev. 1366,  $Q = 18,000$  cfs.
- Figure 13 Intake Velocity Measurements Turbine Mode,  
Reservoir Elev. 1341,  $Q = 18,000$  cfs.
- Figure 14 Outlet Velocity Measurements Pump Mode,  
Reservoir Elev. 1392,  $Q = 15,000$  cfs.
- Figure 15 Outlet Velocity Measurements Pump Mode,  
Reservoir Elev. 1392,  $Q = 15,000$  cfs.
- Figure 16 Outlet Velocity Measurements Pump Mode,  
Reservoir Elev. 1366,  $Q = 15,000$  cfs.
- Figure 17 Outlet Velocity Measurements Pump Mode,  
Reservoir Elev. 1366,  $Q = 15,000$  cfs.
- Figure 18 Outlet Velocity Measurements Pump Mode,  
Reservoir Elev. 1341,  $Q = 15,000$  cfs.

List of Figures (Cont'd)

- Figure 19      Velocity Measurements Near Dam-Pump Mode,  
Reservoir Elev. 1392,  $Q = 15,000$  cfs.
- Figure 20      Velocity Measurements Near Dam-Pump Mode,  
Reservoir Elev. 1366,  $Q = 15,000$  cfs.
- Figure 21      Velocity Measurements Near Dam-Pump Mode,  
Reservoir Elev. 1341,  $Q = 15,000$  cfs.

### List of Photos

- Photo 1      Surface Flow Patterns - Exposure Time - 8 secs,  
Turbine Mode, Reservoir Elev. 1366,  $Q = 18,000$  cfs.
- Photo 2      Surface Flow Patterns - Exposure Time - 8 secs,  
Turbine Mode, Reservoir Elev. 1366,  $Q = 18,000$  cfs.
- Photo 3      Surface Flow Patterns - Exposure Time - 8 secs,  
Pump Mode, Reservoir Elev. 1366,  $Q = 15,000$  cfs.
- Photo 4      Surface Flow Patterns - Exposure Time - 8 secs,  
Pump Mode, Reservoir Elev. 1366,  $Q = 15,000$  cfs.





## I. INTRODUCTION

This report describes hydraulic model studies of the upper reservoir and intake-outlet structure of the Rocky Mountain Pumped-Storage Project. The model included the entire upper reservoir, the intake-outlet structure, the vertical shaft, and a portion of the tunnel. The model was to be operated in both pump and turbine operating modes.

Questions have been raised regarding the acceptable performance of the structure over the entire range of reservoir levels and discharges. The primary purpose of the model studies was to verify that the intake-outlet structure was free from undesirable vorticity and flow characteristics. Improvements to the structure were to be made to correct any undesirable flow conditions as they were encountered. No removals of portions of the as-built structure were to be allowed.

Documentation of the final design of the structure consisted of qualitative vorticity evaluations, reservoir circulation patterns, velocity measurements at the intake, pressure measurements at selected locations, and intake headloss measurements. A description of the 1:70 scale undistorted model and the results of the studies are discussed in the following sections.

## II. MODEL DESCRIPTION

The model was constructed to an undistorted geometric scale of 1:70 and was operated using the Froude Law of Similarity. The plan view of the model shown in Figure 1 indicates the overall layout within the Laboratory's test basin. Several items of specific concern were addressed during model design and construction to alleviate possible outside influences on the testing results. The model was designed to facilitate modification to the dam alignment, reservoir topography and intake-outlet structure.

One of the major items considered was the anticipated operation of the model. In the prototype, the water surface elevation in the upper reservoir continually changes during plant operation in both the pump or turbine modes. In order to better observe intake vorticity in the turbine mode the model was operated at a constant surface elevation. In order to achieve a steady-state reservoir level, water was introduced into the reservoir through the dam at the same rate at which it was being withdrawn. The introduction of the water had to be done very carefully, so that extraneous circulation patterns were not induced by the introduction of flow through the dam. A very low velocity was necessary, which in turn required a large flow area for a given flow rate. After consideration of several schemes, it was decided to make the dam porous to permit addition, or withdrawal, of the water.

The model layout was based on the points of curvature and points of tangency coordinates shown on Drawing No. 5054 H-200. The upper reservoir model was constructed using the base elevation of 1312 ft which corresponded to the elevation of the concrete apron surrounding the intake. Model dam construction consisted of timber framed triangles with a 2H:1V slope on the front face. Triangles were positioned perpendicular to the dike centerline and spaced at intervals ranging from less than 1 ft to approximately 3 ft to accurately represent the dam alignment. The sideslope of the dam was formed by stretching wire hardware cloth between the front face of the triangles. The hardware cloth was then covered with a high porosity soilcloth which, in turn, was covered with a 1/2 inch thick layer of pea gravel ranging in size from 1/8 inch to 3/8 inch diameter. After initial testing, the soilcloth developed problems with clogging. This clogging was most probably due to fine debris inherent in the Mississippi River water supply and microbial growth caused by the continual high moisture content. In order to alleviate this problem, the soilcloth was removed from the dam framing at each end of the model and replaced with 8 mesh wire screening. Throughout the study, the dam surface closest to the intake was made impervious to prevent local inflows or outflows from affecting the flow patterns near the intake. Figure 2 shows the model basin and the extent of each of the dam porosity zones.

The reservoir invert topography shown in Figure 3 was formed in the model by adding pea gravel above the laboratory floor. Initial testing indicated that it was not necessary to stabilize the bed. The pea gravel was chosen to appropriately model the anticipated diameter of the material created during construction of the upper reservoir. The use of a loose bed permitted easy modification of the bed topography should it become necessary. A vertical sheet metal barrier was placed along the top of the 20H to 1V slope leading to the structure to prevent seepage through the pea gravel from entering the structure.

The intake-outlet structure was constructed of transparent Lucite in accordance with the dimensions given in Harza Drawing Nos. 5054 H-206 and 5054 H-207. Three features of the structure were considered not to have a significant impact to the structure performance and were therefore omitted from the model. The small filling channel and conduit were not included because they were within the crest of the structure. Although the existing roof of the intake-outlet structure is thicker at the center than at the edges, the model was constructed with the roof of a constant thickness of 2 ft because the varying roof thickness had no bearing on the flow conditions. Finally, the minor slope on the invert apron outside the structure was not modeled.

The structure diffuser was fabricated of fiberglass and was therefore not transparent. A smooth gel coat followed by the fiberglass required for strength purposes was applied over a wooden male mole machined to the proper dimensions.

The vertical shaft was made from transparent plastic tubing of 6-in. ID to the scaled length. The lower elbow of 90 ft. radius was replaced with an elbow of six segments. This elbow was fabricated from 6 in. ID transparent tubing. The elbow was followed with a 28 ft straight length of 6-in. ID PVC pipe installed at about a 0.75 percent slope. Although this is less than the as-built tunnel slope of 1.5 percent, it was decided that the difference should not influence the experimental results. The longitudinal alignment of the lined tunnel has also been changed. To facilitate model construction at the available Laboratory site, it was necessary to rotate the tunnel alignment about 120° clockwise from the prototype position. This was not expected to result in any significant differences in the performance of the intake-outlet structure.

Twenty-five pressure taps were installed on the underside of the intake roof, the crest, the intake diffuser, and the vertical shaft. The location of these taps are shown in Figures 4 and 5. Note that Taps 1 through 10 are in the roof. Taps 11 through 25 are located within the crest, diffuser, and vertical shaft in the same vertical plane as Taps 1 through 6. All pressure taps consisted of 1/16-inch diameter holes which were enlarged at the outside of the wall to accommodate larger diameter tubing. Mean pressures were measured using the reservoir level as a reference. The tubes were connected to a manometer bank and the water levels were measured for Taps No. 1 through 10, with a cathetometer having a resolution of 0.1 mm. The deflections at other taps were generally larger and were read directly off the manometer board scale.

Figure 6 shows a schematic of the piping system used to supply and remove water from the model. To eliminate the possibility of pump vibrations transmitting through the pipe to the intake and vertical column and affecting pressure measurements in those areas, the pump mode of flow was gravity driven. Flow and water level control was accomplished using a combination of 4 and 6 inch gate valves. Flow measurement was provided by calibrated orifices installed in the 6-in. supply and discharge lines connected to Meriam 3 manometers.

### III. MODEL OBSERVATIONS

#### A. PHASE I - TESTING OF INITIAL DESIGN AND MODIFICATIONS

Phase I testing consisted of qualitatively observing the initial design and each proposed modification for indication of any undesirable effects. Of specific concern was vortex formation at the structure and detrimental flow patterns, such as a poor distribution of flow entering the structure, observed using dye injection. Initial testing involved observing pool drawdown for two flows and pool recharge for one flow. The three test conditions are summarized below in Table 1.

Table 1.

Test Condition	Operating Mode	Flow	Water Surface Elevation
1	Turbine	18,000 cfs	1392—>1312
2	Turbine	27,000 cfs	1392—>1312
3	Pump	15,000 cfs	1312—>1392

Flow Conditions 1 and 3 are typical operating conditions, while Condition 2 is a 1.5 times Froude test case often observed in such studies as it accentuates detrimental flow phenomena and makes them easier to observe.

Observation of the as-built structure performance indicated minimal detrimental flow patterns as the general flow patterns toward, and away from the structure, were quite smooth. Figure 3 defines the orientation of the structure for documentation of vortex locations and strengths. Testing of flow Condition 1 indicated infrequent vortex formation was evident between the twelve o'clock and three o'clock positions, and even less frequent formation near ten o'clock. The vortex formation occurred most typically between the reservoir elevations of 1355 and 1370 ft. Testing under Flow Condition 2 increased the vortex strength with some dye core vortices noted between the twelve and three o'clock positions. The frequency of vortex formation increased slightly with the increased flow. However, it remained intermittent and again occurred most frequently between reservoir elevations 1355 and 1370 ft. No movement of the peagravel which forms the reservoir bottom near the intake was observed. Pumping discharge appeared to cause a significant impingement velocity on the near dam sideslope. The strength and location of the impingement will be further discussed in the section describing the Phase II tests.

Several minor modifications, such as splitter vanes installed between the vertical piers, a vertical lip extending upward from the intake roofline, and flow obstruction wedges placed between the intake and the nearby dam face were tried in an attempt to reduce or eliminate the vorticity. Observations of the splitter vanes and vertical piers indicated no noticeable effect upon the vortex formation. By varying placement of the wedges, it was possible to move the location at which the vortices form. However, no change in vortex frequency or strength was noted.

A more significant modification involved installation of a suspended cone beneath the roof of the structure as shown in Figure 7. Testing of this modification indicated that the cone produced no observable improvement on the performance of the structure. In an attempt to document the performance of the structure with the cone, a headloss study was conducted between the upper reservoir water surface elevation and pressure Tap No. 25 shown in Figure 4. Testing was done both with and without the suspended cone for comparison purposes. Test results are summarized in Table 2. Due to the 1:70 model scale, the very small losses occurring in either turbine or pump mode, and the length of tubing required for the testing comparison, the accuracy of each reading may have a significant amount of error.

Partway through the initial testing program, Harza Engineering requested that the topography be modified from that shown in Figure 3 to that shown in Figure 8. The modification involved putting a very slight slope to a previously flat portion of the reservoir bottom. The revised topography did not noticeably affect flow conditions in the proximity of the structure or its performance. As the revised topography is more likely to be constructed, all subsequent testing was done using the revised reservoir bottom.

## B. PHASE II - TESTING OF FINAL DESIGN AND DOCUMENTATION

### 1. Pressure Measurements

The suspended cone modification produced no observable improvements in structure performance over the as-built structure. It was therefore discarded as a viable alternative. Phase II of the test program involved more detailed testing of the as-built structure and the sloping bed of the reservoir as shown in Figure 8. The testing was done to ascertain information regarding the structure's pressure distribution and the reservoir velocity patterns entering and exiting the structure, and to further document the reservoir surface flow patterns.

The pressure measurement system utilized the series of twenty-five 1/16-in. pressure taps shown in Figures 4 and 5 connected to a multiple column manometer board using clear plastic tubing. The measurements were divided into two sets: Set 1 consisting of Tap Nos. 1 through 10 and Set 2 consisting of all remaining taps. Such a division was necessary due to the two-level nature of the models. Tap Nos. 1 through 10 were accessible from third floor of the Laboratory, and Tap Nos. 11 through 25 were accessible from the second floor of the Laboratory. Piezometric pressure

Table 2

Structure Headloss Summary  
Tap No. 25 vs. Reservoir Water Surface

Run No.	Flow Mode	Reservoir Elev. ft	Stilling Well Elev. ft	Delta ft	Q cfs	V <sup>2</sup> /2g ft	Head Loss (Model) ft	Head Loss (Proto) ft	H <sub>L</sub> /V <sup>2</sup> /2g
*1C	Turbine	1.462	1.382	0.080	0.440	0.075	0.005	0.350	0.067
*2C	Turbine	0.912	0.835	0.077	0.440	0.075	0.002	0.140	0.027
*1D	Turbine	1.296	1.126	0.170	0.660	0.168	0.002	0.140	0.012
*2D	Turbine	1.024	0.516	0.175	0.660	0.168	0.007	0.490	0.042
*1F	Pump	1.255	1.232	N/A	0.367	0.052	0.029	2.030	0.558
**1C1	Turbine	1.456	1.381	0.075	0.440	0.075	0.000	0.000	0.000
**2C1	Turbine	0.899	0.809	0.090	0.440	0.075	0.015	1.050	0.200
**1D1	Turbine	1.312	1.112	0.200	0.660	0.168	0.032	2.240	0.190
**2D1	Turbine	1.029	0.811	0.208	0.660	0.168	0.040	2.800	0.238
***1C2	Turbine	1.450	1.371	0.079	0.440	0.075	0.004	0.280	0.053
***2C2	Turbine	0.903	0.817	0.086	0.440	0.075	0.011	0.770	0.146
***1D2	Turbine	1.347	1.135	0.212	0.660	0.168	0.044	3.080	0.261
***2D2	Turbine	1.020	0.844	0.176	0.660	0.168	0.008	0.560	0.048
***1F2	Pump	1.254	1.218	N/A	0.367	0.052	0.016	1.120	0.308

Bed Type/Intake Configurations:

*	Flat	-	No Cone
**	Sloping	-	No Cone
***	Sloping	-	With Cone

Table 3

## SUMMARY OF PIEZOMETRIC PRESSURE HEAD MEASUREMENTS

P-Po (ft of water) Prototype

TAP NO.	TAP ELEV.	RUN 1 Turbine Mode (27,000 cfs)	RUN 2 Pump Mode (13,500 cfs)	RUN 3 Pump Mode (15,000 cfs)	RUN 4 Pump Mode (15,000 cfs)
1	1337	- 0.434	1.638		
2	1337	- 0.364	.022		
3	1337	- 0.252	.399		
4	1337	- 0.140	0		
5	1337	- 0.231	.021		
6	1337	- 0.210	.140		
7	1337	0	-.070		
8	1337	- .091	.161		
9	1337	- 0.210	.142		
10	1337	- 0.210	.147		
11	1312	N/A		N/A	N/A
12	1312	.88		.88	.70
13	1312.76	.88		.88	.88
14	1316.84	.29		.88	.88
15	1317	- 2.92		.88	.88
16	1317	- .58		1.17	1.17
17	1306.1	N/A		N/A	N/A
18	1301.76	- 1.17		1.17	1.17
19	1275.04	- 2.92		.58	1.17
20	1246.12	- 5.54		.58	.70
21	1219.40	-10.50		.58	-.12
22	1215.03	-11.70		-.58	-.12
23	1167.22	10.50		-.29	.29
24	1117.22	-11.08		-.29	.29
25	967.22	-11.70		.58	1.17

NOTE: All piezometric pressure head measurements referenced to Reservoir El. 1366.



measurements are summarized in Table 3 for each of the flow conditions tested and the indicated pressures are with reference to the reservoir water surface. The two test conditions were the turbine mode at a reservoir elevation of 1366 ft with a flow of 18,000 cfs and the pump mode at the same reservoir elevation with a flow of 15,000 cfs. Due to very small deflections noted in Tap Nos. 1 through 10 during testing of the turbine mode, flow was increased to the 1.5 times Froude flow conditions (27,000 cfs) in an attempt to obtain more reliable and accurate data. In addition, all measurements taken for Tap Nos. 1 through 10 were done using a cathetometer with a measurement resolution of 0.1 mm.

The pressure measurements provide the hydraulic gradeline piezometric within the structure. Piezometric pressure observations showed that fluctuations of the pressures were extremely low. Placement of flush mounted transducers was discussed. However, this method was not chosen due to possible effects of curved model surfaces on the data. Tap No. 11 was not installed due to a structural beam underneath the model, and Tap No. 17 was apparently plugged during the data sampling.

Dynamic pressure measurements were taken at six tap locations where flow separation was expected to cause pressure fluctuations. The six taps designated for dynamic pressure tests were Taps 7, 8, 9, 10, 15, and 16. Dynamic pressures were recorded during both pump and turbine operating modes at reservoir El. 1366. A Validyne Model Dp45 pressure transducer having a one inch full scale (0.036 psi) deflection was used to sense the pressure fluctuations.

The pump mode tests were made with a discharge of 15,000 cfs. The pump mode operation produced the highest pressure fluctuations, even though the flow leaving the structure was primarily radial. The resulting fluctuation range recorded at each tap is shown on Table 4. The largest fluctuation recording was 0.14 ft at Tap 7.

The magnitude of pressure fluctuation during the turbine mode operation was very small. The turbine mode tests were run with a

Table 4  
Summary of Dynamic Pressure Head Measurements  
Peak to Peak (ft of water) Prototype)

Tap No.	Turbine Mode (27,000 cfs)	Pump Mode (15,000 cfs)
7	0.05	0.14
8		0.11
9		0.12
10	nil	0.05
15	02	nil
16		0.023

Note: All measurements taken for reservoir surface el. 1366.

discharge of 27,000 cfs, or 1.5 times Froude, to accentuate the fluctuations. Even with this increased flow, the fluctuation magnitude ranged from 0 to 0.05 ft (prototype). The pressure fluctuations for the turbine operation are also shown in Table 4. Since the magnitude of the fluctuations was small for a flow 1.5 times the normal maximum turbine flow of 18,000 cfs, and the approach velocities are less than 2 ft/sec at the pier noses, further fluctuation measurements at the 12:30 location displaying an inflow angle of 30 degrees appeared to be unwarranted and were not taken.

## 2. Surface Flow Patterns

Photographic documentation of the surface flow patterns was taken using both still photography and video tape recording showing the turbine and pump design flows at three different stable water surface elevations. Paper confetti mixed with a small amount of detergent to prevent clumping was sprinkled on the water surface and used to illustrate the flow patterns. Due to the time dependent nature of surface flow phenomena, the videotape supplement to this report provides a better indication of the overall surface flow patterns.

Photos 1 and 2 show the surface flow pattern observed during testing of a turbine mode at reservoir elevation 1366 and a flow of 18,000 cfs. A surface swirl was evident near two o'clock on an otherwise relatively quiet water surface. The crossflow across the intake roof was from twelve o'clock toward five o'clock. The surface swirl may be an indication of a small upwelling near the reservoir dam caused by two subsurface flows which approach the intake along the toe of dam from both directions meeting opposite at the twelve o'clock position. These subsurface flows were indicated using dye injection during Phase I testing. Please note that all confetti shown in Photos 1 through 4 are floating on the surface and, therefore, are indicative of surface flow phenomena only.

Photos 3 and 4 show the surface flow pattern observed during testing of the pump mode at a flow of 15,000 cfs. The rotation indicated near the intake is surface flow turbulence caused by the upwelling evident along the dam. Upwelling along the dam stems from the discharge exiting the intake between approximately ten o'clock and two o'clock. This discharge proceeds to the dam where it is then forced upward. Upon reaching the surface, this flow exits the intake region by proceeding back over the intake, as well as right and left along the dam as can be seen in the photos.

### 3. Velocity Measurements

Velocity measurements were taken at several depths at four locations around the periphery of the intake. Measurements were taken with reservoir El. 1392, 1366, and 1341 for a pump mode flow of 15,000 cfs and a turbine mode flow of 18,000 cfs. A Marsh-McBirney two-component magnetic current meter model 523, with a probe diameter of 0.5 inches, was used to measure the velocities. Measurement stations were established at twelve-thirty, three-thirty, six-thirty, and nine-thirty positions as defined by the intake orientation shown in Figure 3. The velocity was measured just below the water surface, midway between the water surface and the top of the intake roof, just above the top of the intake roof, just below the intake crown, at the center of the clear structure opening, and just above the structure invert. Measurements were taken just outside the perimeter of the roofline (approximately 1/4-inch model). For the pump mode flows, velocities were also obtained at several locations along the near face of the upper dam at the elevation at which the maximum exit velocity was observed. Structure velocity measurements are summarized in Figures 9 through 18, using scaled arrows to indicate the approximate magnitude. The flow angle and magnitude are listed near each measurement location.

In the turbine mode, velocities above the intake roof were generally low with the reservoir at El. 1392 and 1366. Flow approaching the structure for these cases was primarily radial at all measurement locations except one. An inflow angle of approximately 30° was apparent at twelve-thirty at measurement level 1327 MSL and below. This was due to the relatively tight proximity of the structure and the upper dam. Phase I observations indicated that submerged flow approached the structure at lower levels along the dam from the recessed region east-southeast of the structure. Approach velocity magnitudes appear to be higher at twelve-thirty and three-thirty at all elevations below the intake crown. Approach velocity angles indicated for testing at reservoir elevation 1341 are, in part, due to an increased effect of bed topography and, in part, due to possible approach flow effects, however minimal, caused by water entering through the model sidewalls at this test level.

Pump mode velocity measurements exhibited significant turbulence above the structure roof. Measurements between the roof crown and structure invert indicate that separation occurs at the intake crest. These measurements confirm the observations made during the Phase I tests. Radial exit velocities on the order of 5 ft/s were measured just below the crown. Return velocities toward the structure of up to 1 ft/s at elevations below the structure crest elevation of 1317 ft were also recorded.

Figures 19 through 21 show the magnitude of velocity components measured near the dam for each of the pump mode tests. Measurements were taken at elevation 1336 ft MSL for all three tests, which was the elevation of maximum exit velocity observed for each test. Distances are given in feet from the centerline of the intake rounded to the nearest 5 ft. Measurements were taken as close as practical to the dam slope. Measurements are given for both the x and y components of the velocity as this may be more descriptive than just a magnitude and an angle.

However, since the meter is two-dimensional in its current measurement capabilities, a vertical component may also exist. Velocity measurements confirm the surface flow patterns shown in photographs 3 and 4, as well as the observations taken in Phase I testing. Velocity components, both perpendicular and parallel to the embankment, exhibited magnitudes up to approximately 2 ft/s prototype at the elevation sampled.

#### IV. CONCLUSIONS

Qualitative testing of the as-built design was undertaken as part of Phase I. The model was observed in the turbine mode under falling head conditions. Mild vorticity was noted from approximately twelve o'clock to three o'clock and was most evident at midpool level reservoir elevations. Vortex strength was limited to surface rotation with some dye core formations. No air core vortices were noted at anytime during the Phase I tests. Several minor modifications were tried in an effort to improve flow conditions and structure performance without success at reducing vortex formation. Testing of modifications was observed by Harza personnel. A suspended cone was installed on the underside of the structure roof and tested for its effect on reducing headloss with no significant change apparent. After review by Harza personnel, it was decided that the vortex formation did not have a detrimental effect on the intake performance, and that Phase II testing should be initiated on the as-built design with the reservoir invert modification as shown in Figure 8. Based on Phase I observations, three reservoir elevations of 1392, 1366 and 1341 ft MSL were chosen for steady state testing in Phase II.

Phase II testing provided the qualitative results given earlier in the report. Pressure and velocity measurements indicated acceptable intake performance over the full range of reservoir levels. Still photography indicated the surface flow patterns in the vicinity of the intake are acceptable. A videotape to document the surface flow patterns was also made and is included as a supplement to this report. The as-built structure performance was satisfactory and no major problems are expected during the future operation of the project.

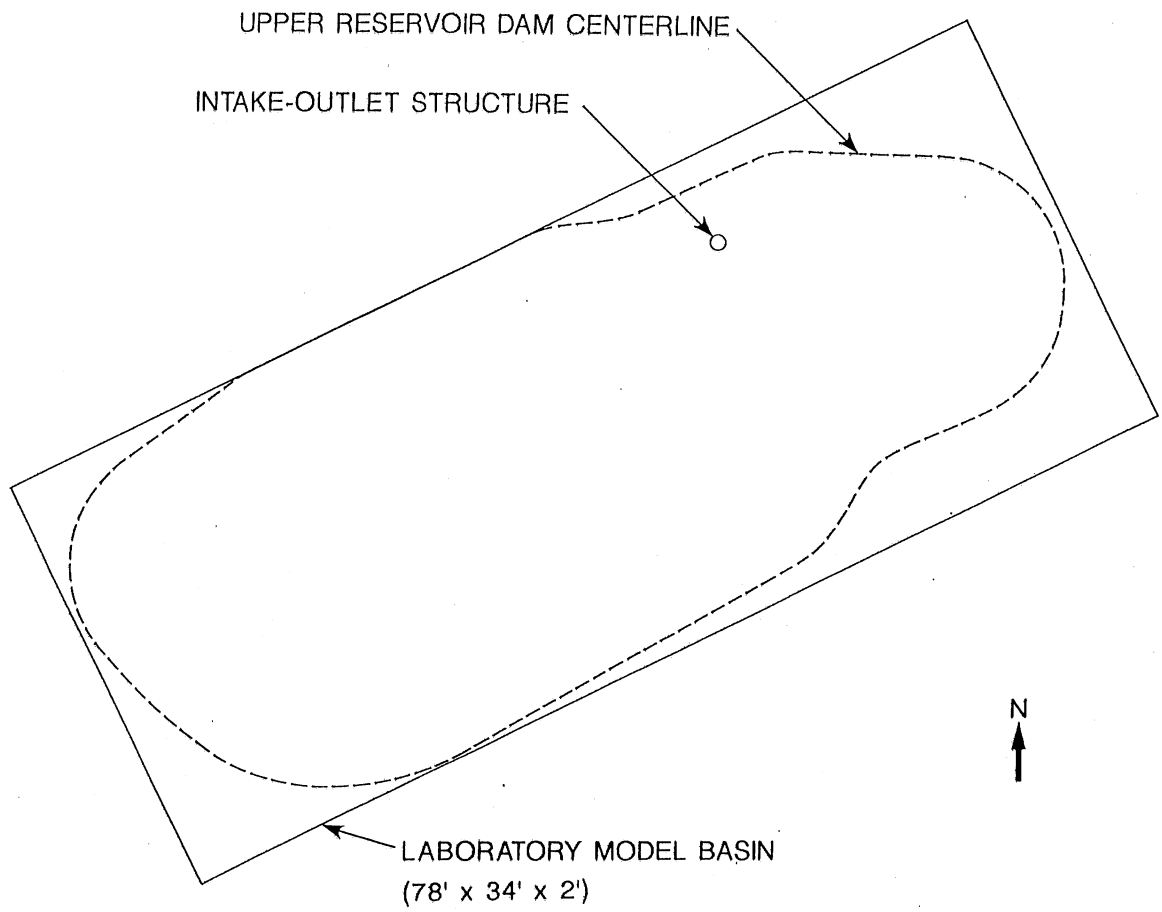

Figure 1. Overall Upper Reservoir Layout in Model Basin.

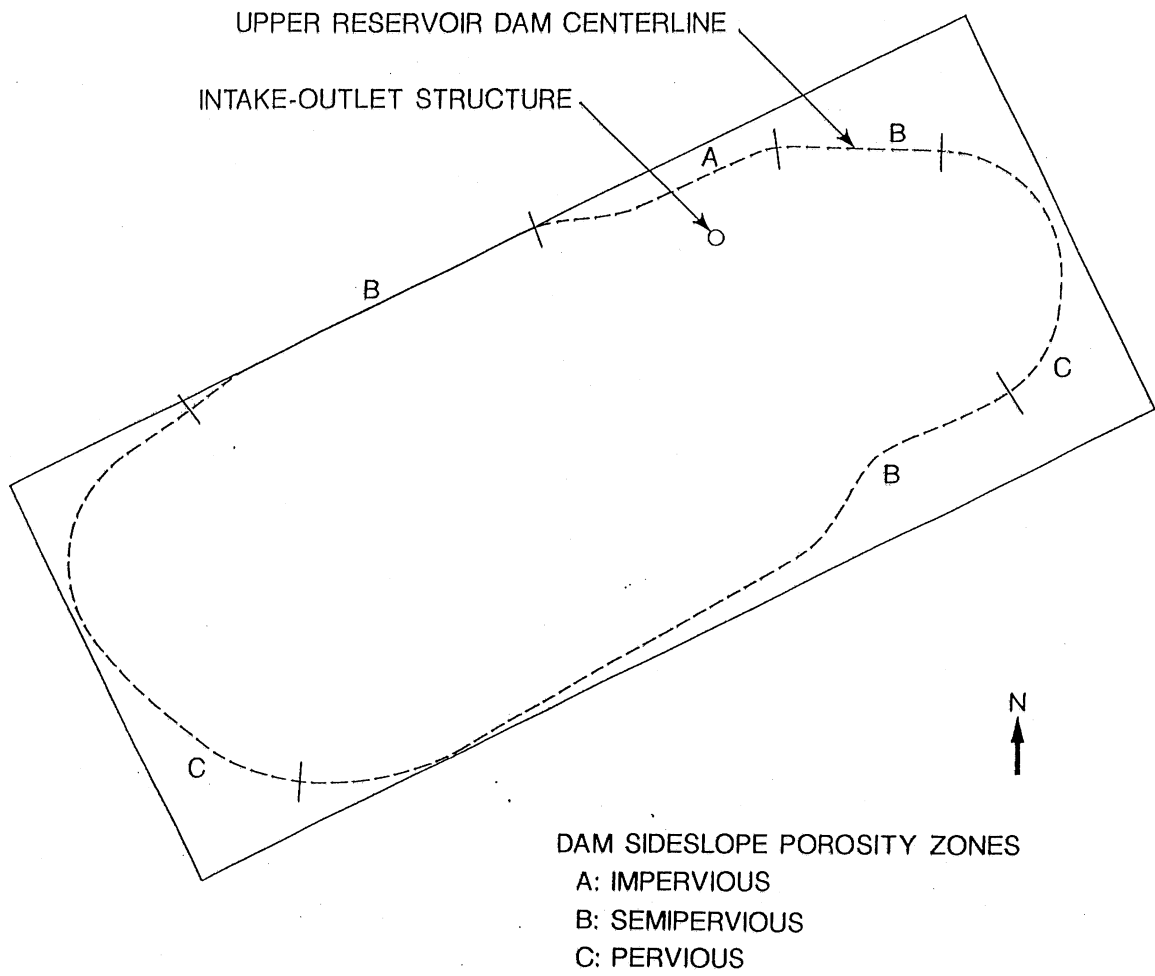

Figure 2. Dam Sidewall Porosity Zones.

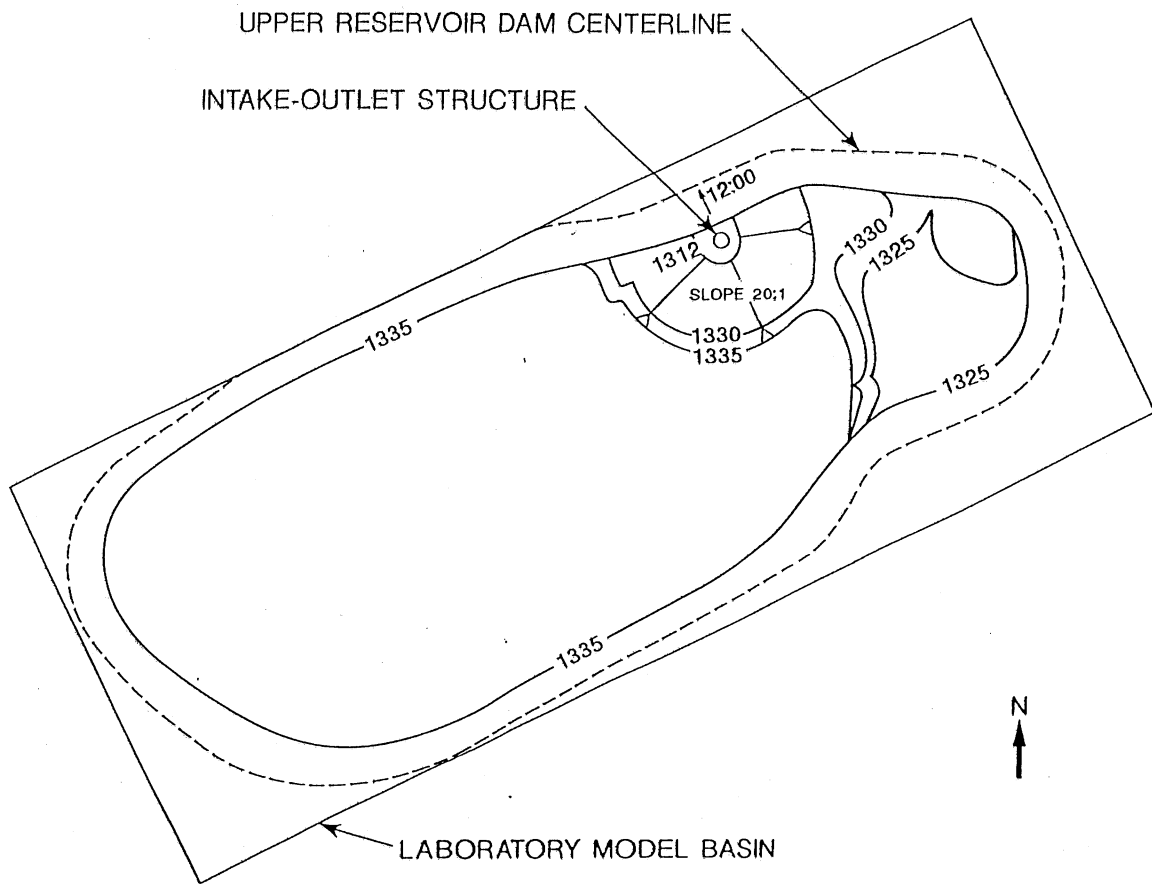

Figure 3. Initial Upper Reservoir Bed Topography.



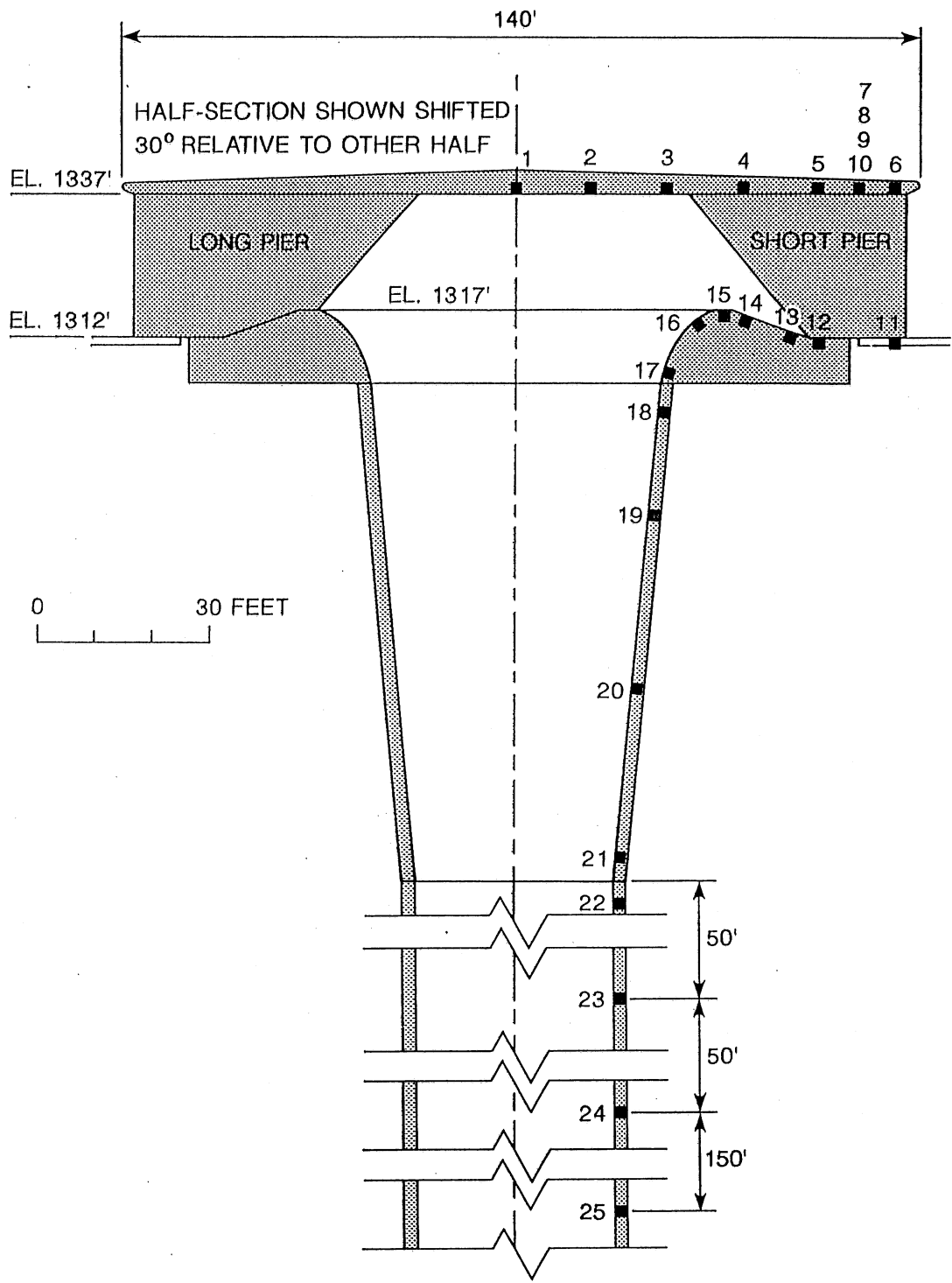

Figure 4. Pressure Tap Locations - Elevation.

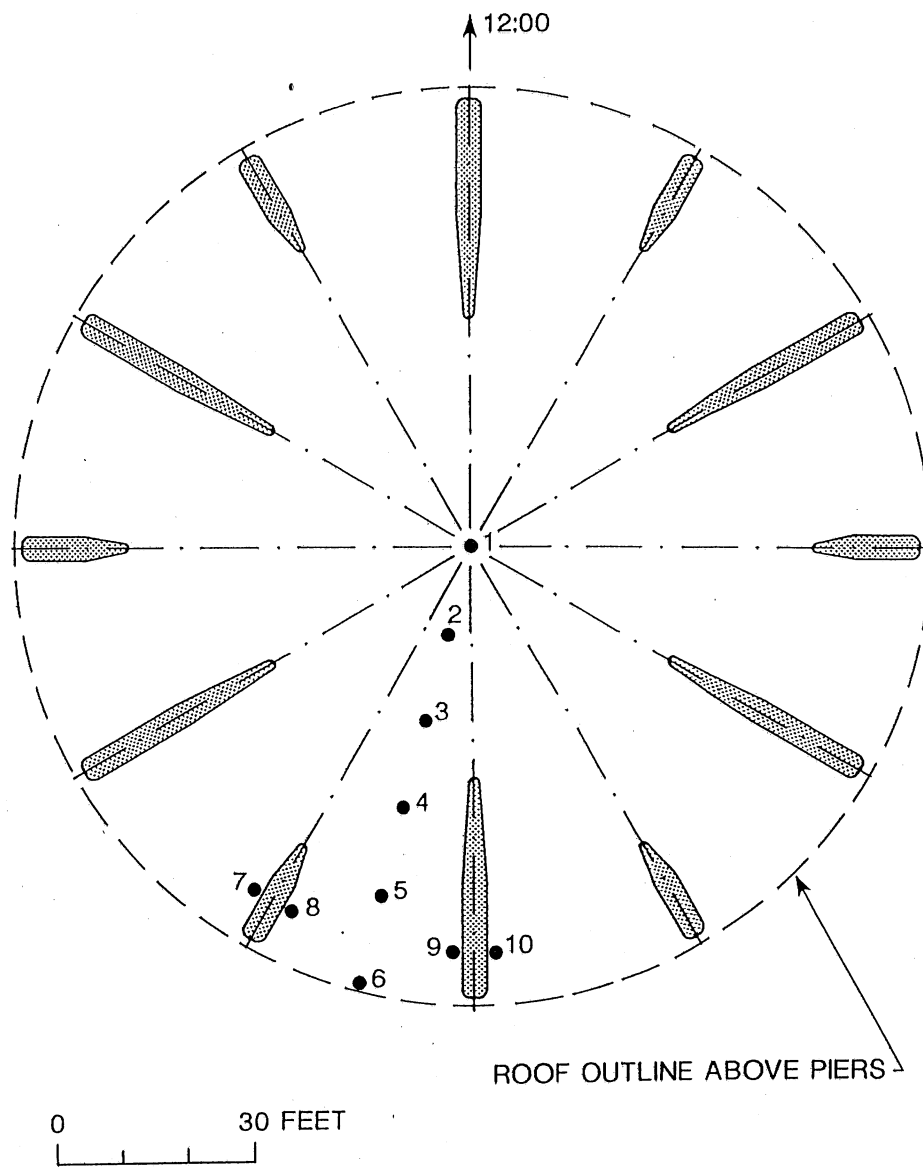

Figure 5. Pressure Tap Locations in Roof - Plan.

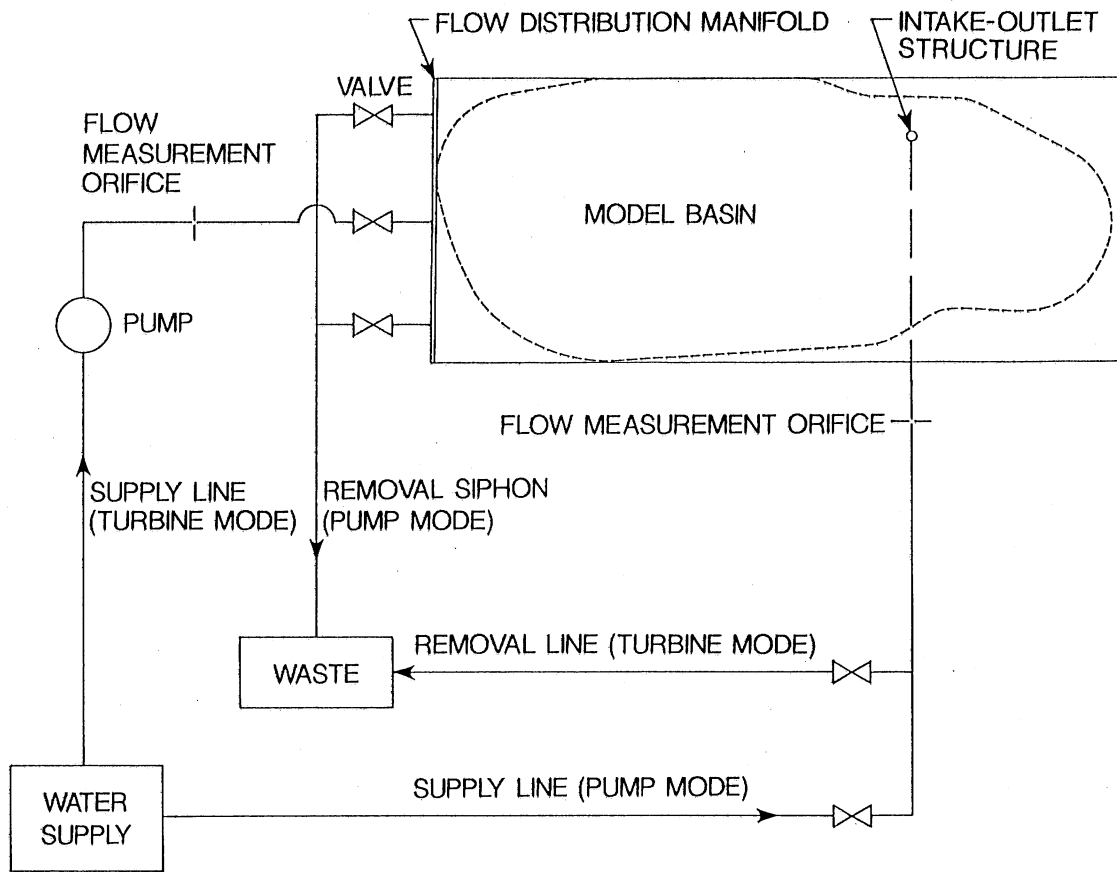

Figure 6. Schematic of Model Piping System.

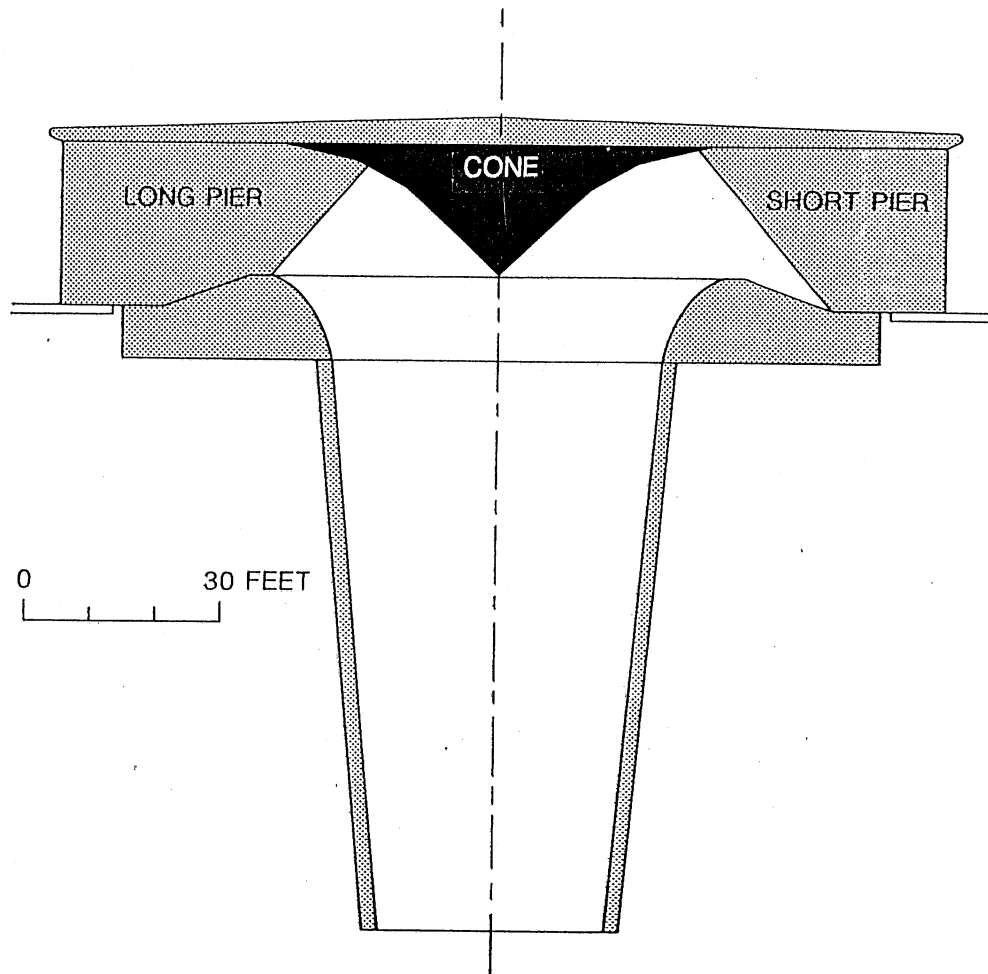

Figure 7. Suspended Cone Modification to Roof.

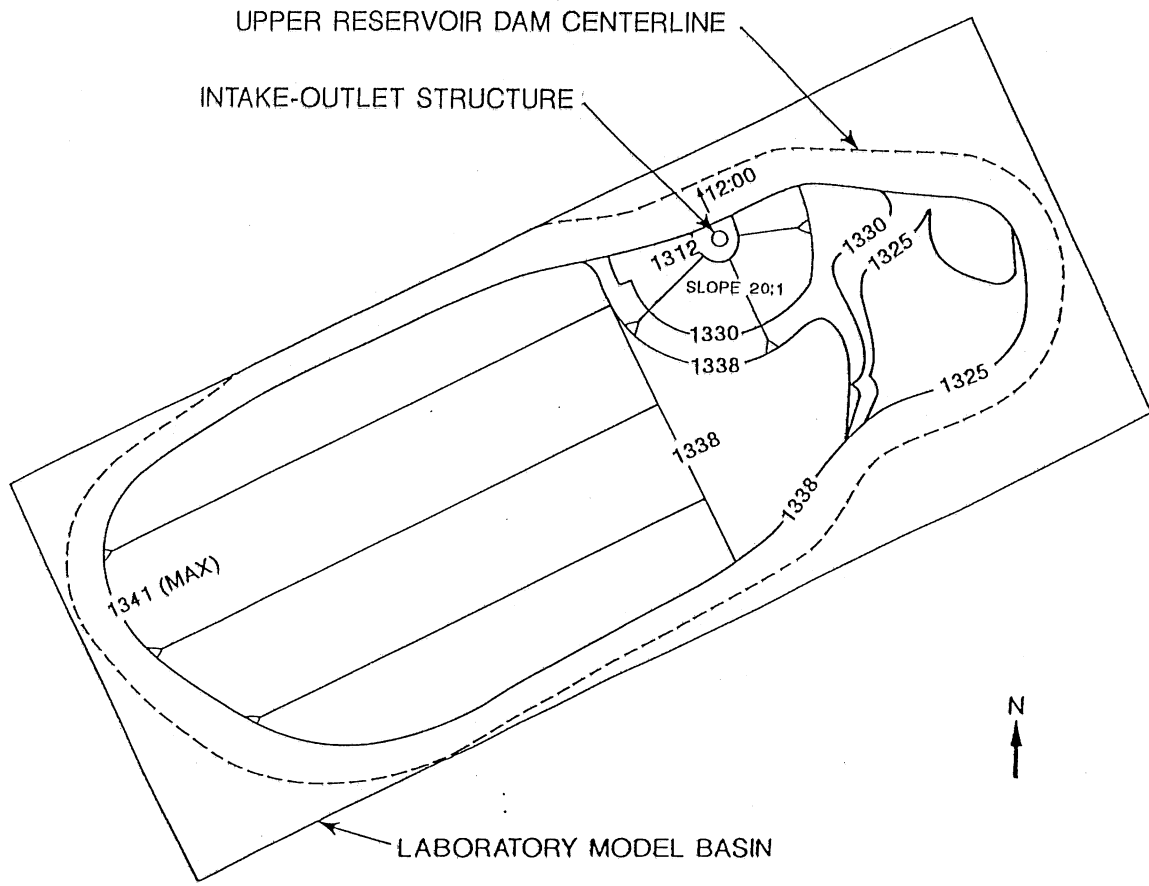

Figure 8. Modification to Upper Reservoir Bed Topography.

# VELOCITY MEASUREMENTS AT STRUCTURE

OPERATING MODE TURBINE  
 WATER SURFACE ELEVATION 1392'  
 FLOW RATE 18,000 CFS

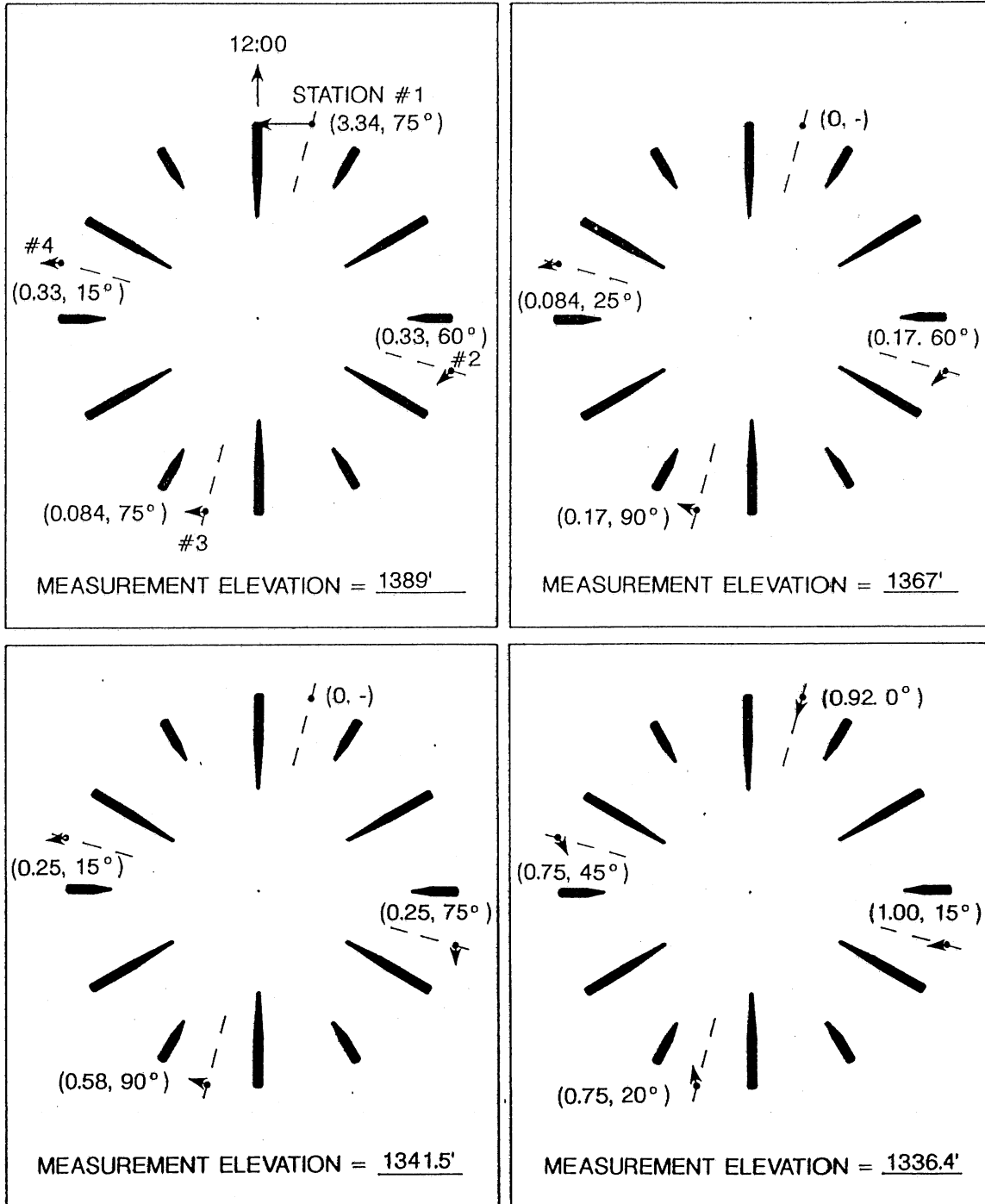

Figure 9. Intake Velocity Measurements Turbine Mode, Reservoir Elev. 1392, Q = 18,000 cfs.

VELOCITY MEASUREMENTS AT STRUCTURE

OPERATING MODE TURBINE

WATER SURFACE ELEVATION 1392'

FLOW RATE 18,000 CFS

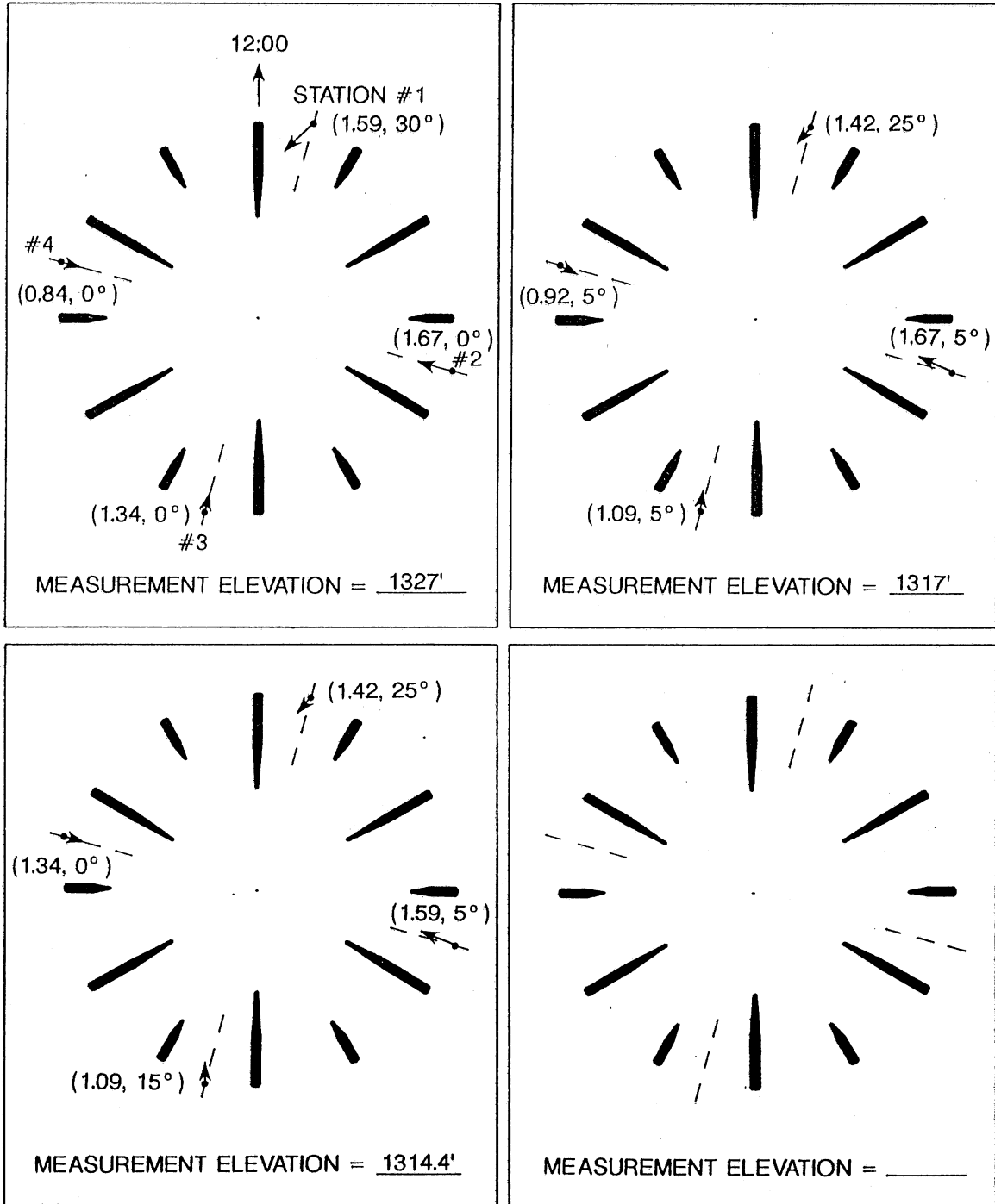

Figure 10. Intake Velocity Measurements Turbine Mode, Reservoir Elev. 1392, Q = 18,000 cfs.

# VELOCITY MEASUREMENTS AT STRUCTURE

OPERATING MODE TURBINE  
WATER SURFACE ELEVATION 1366'  
FLOW RATE 18,000 CFS

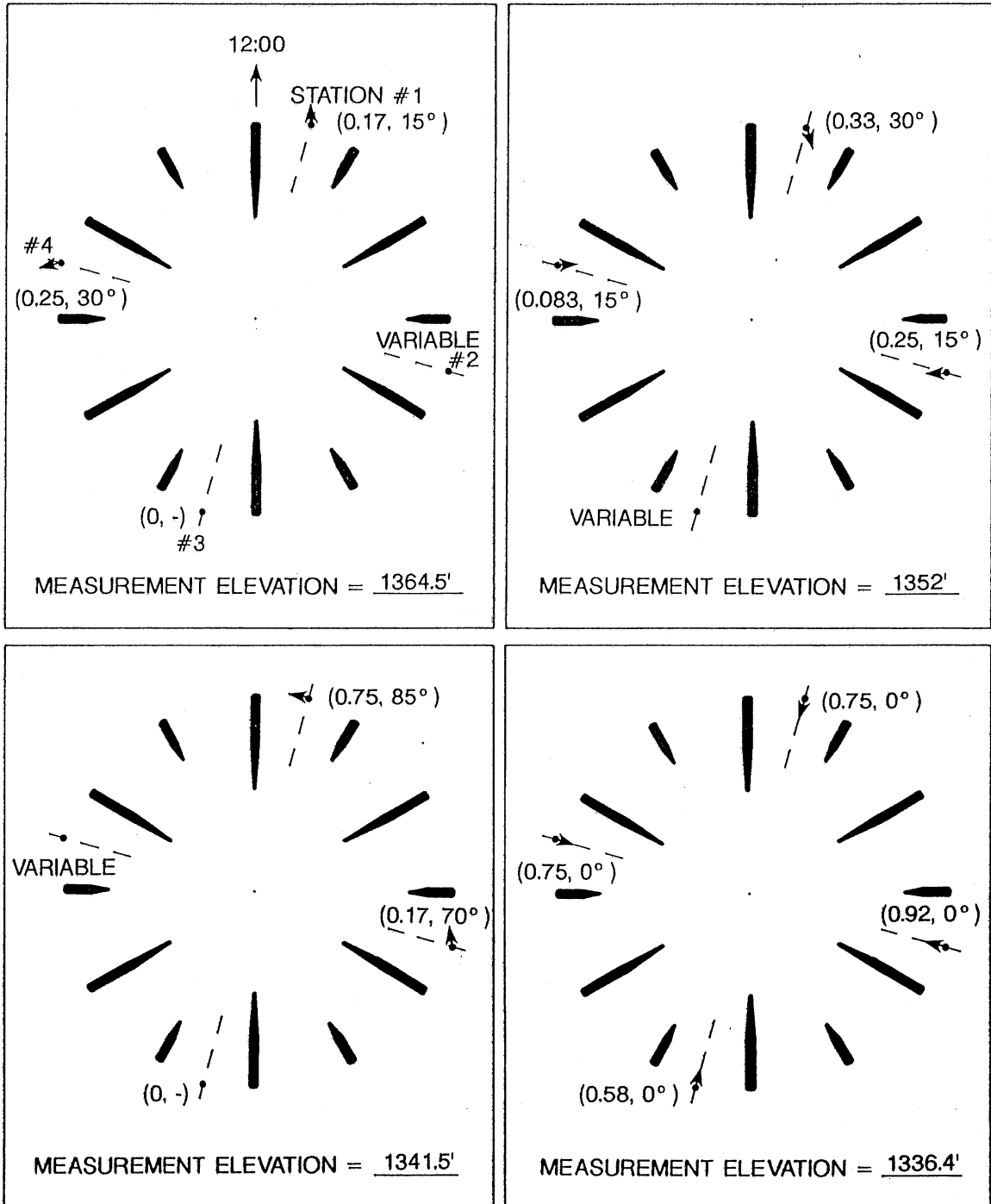

Figure 11. Intake Velocity Measurements Turbine Mode, Reservoir Elev. 1366, Q = 18,000 cfs.



VELOCITY MEASUREMENTS AT STRUCTURE

OPERATING MODE TURBINE

WATER SURFACE ELEVATION 1366'

FLOW RATE 18,000 CFS

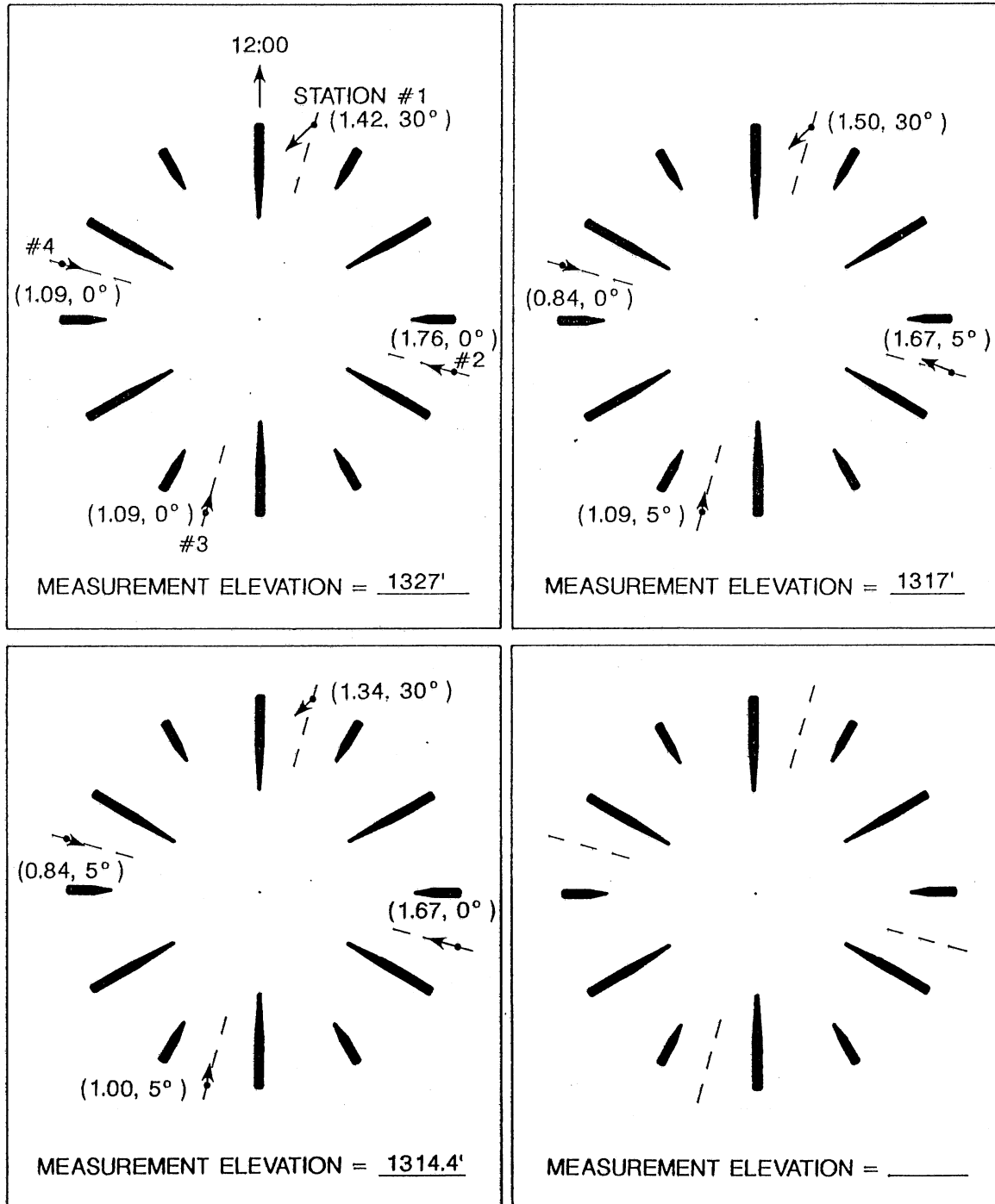

Figure 12. Intake Velocity Measurements Turbine Mode, Reservoir Elev. 1366, Q = 18,000 cfs.

VELOCITY MEASUREMENTS AT STRUCTURE

OPERATING MODE  TURBINE   
 WATER SURFACE ELEVATION  1341'   
 FLOW RATE  18,000 CFS

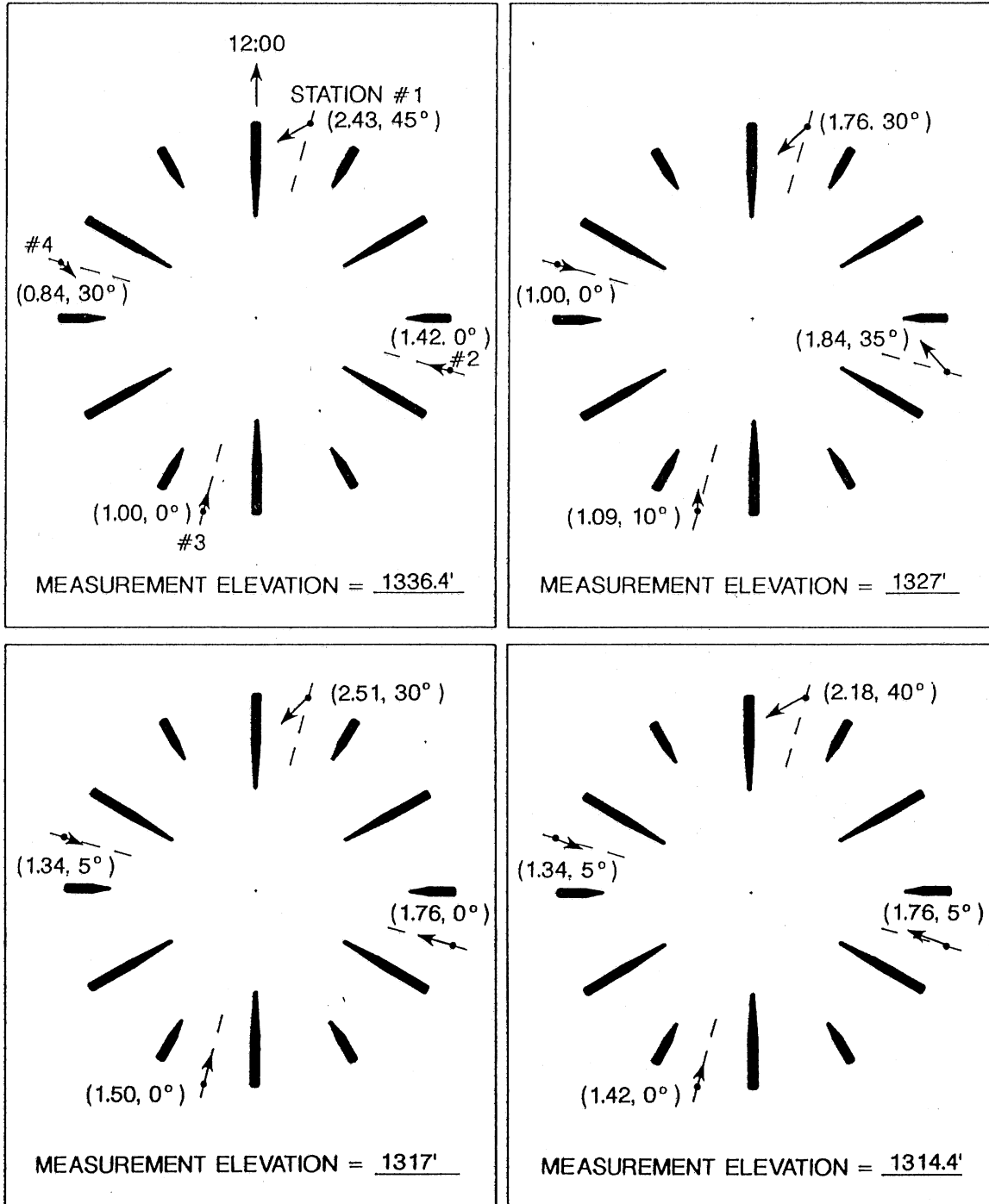

Figure 13. Intake Velocity Measurements Turbine Mode, Reservoir Elev. 1341, Q = 18,000 cfs.

VELOCITY MEASUREMENTS AT STRUCTURE

OPERATING MODE PUMP  
 WATER SURFACE ELEVATION 1392'  
 FLOW RATE 15,000 CFS

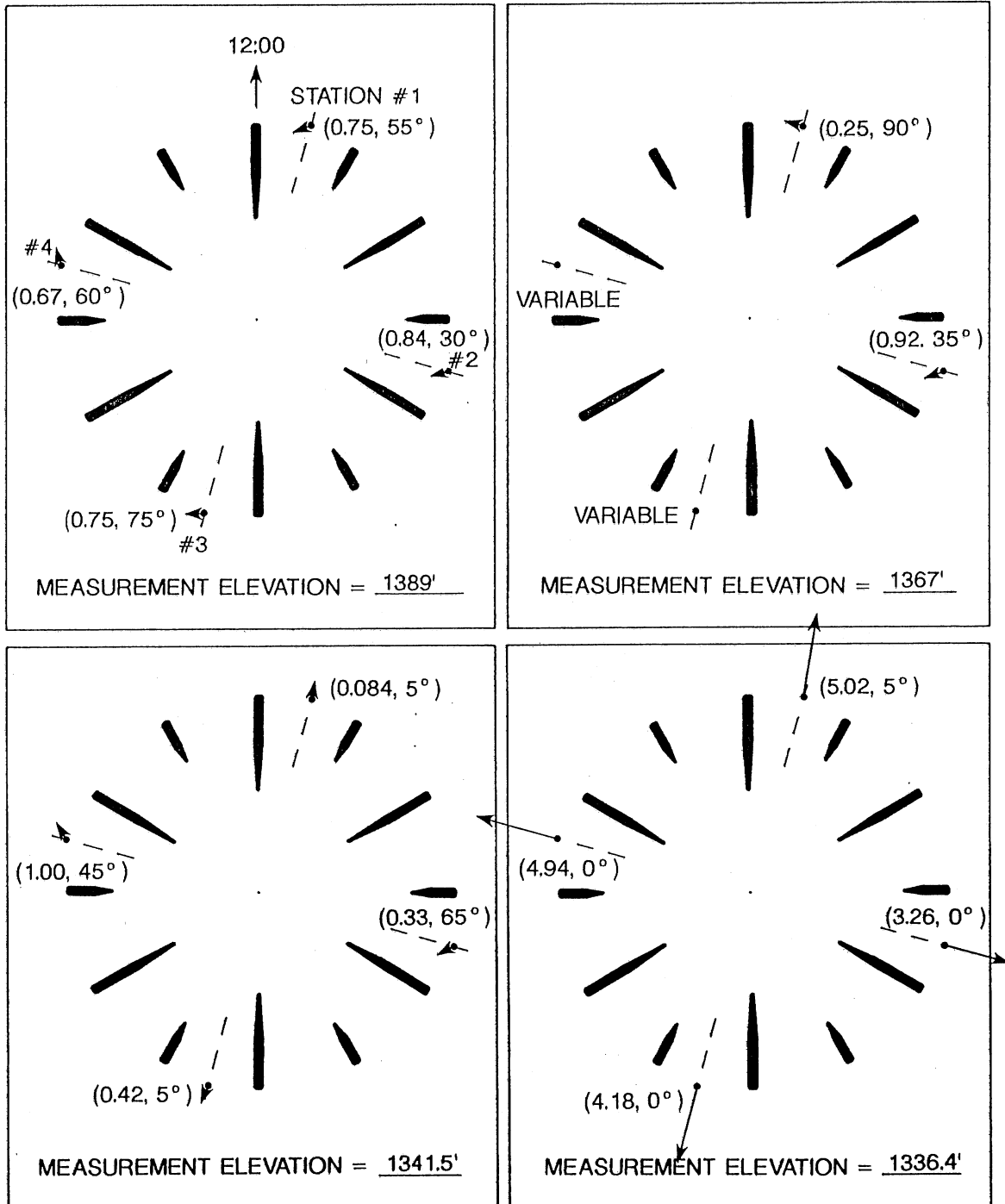

Figure 14. Outlet Velocity Measurements Pump Mode, Reservoir Elev. 1392, Q = 15,000 cfs.

# VELOCITY MEASUREMENTS AT STRUCTURE

OPERATING MODE PUMP

WATER SURFACE ELEVATION 1392'

FLOW RATE 15,000 CFS

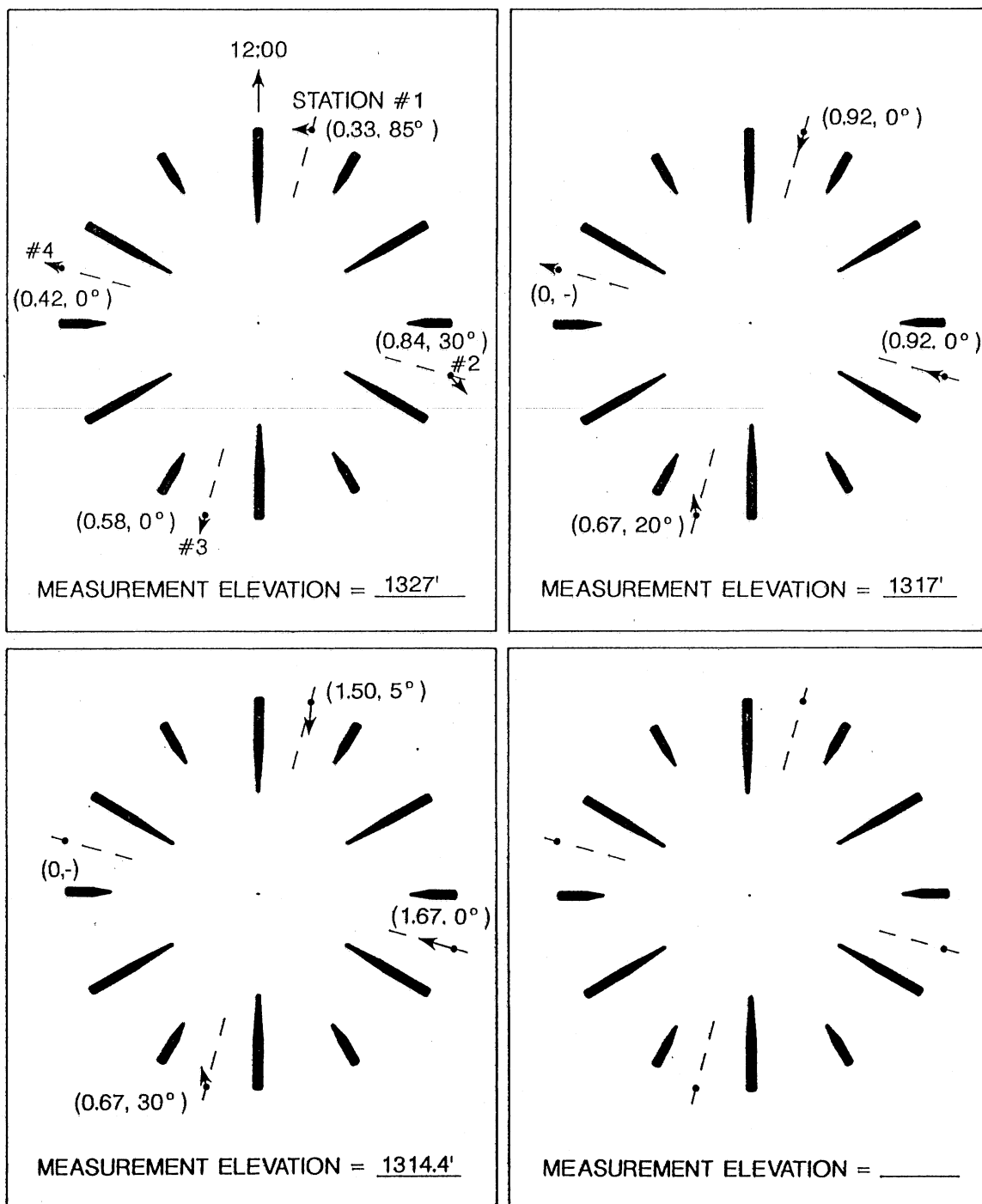

Figure 15. Outlet Velocity Measurements Pump Mode, Reservoir Elev. 1392, Q = 15,000 cfs.

# VELOCITY MEASUREMENTS AT STRUCTURE

OPERATING MODE PUMP  
 WATER SURFACE ELEVATION 1366'  
 FLOW RATE 15,000 CFS

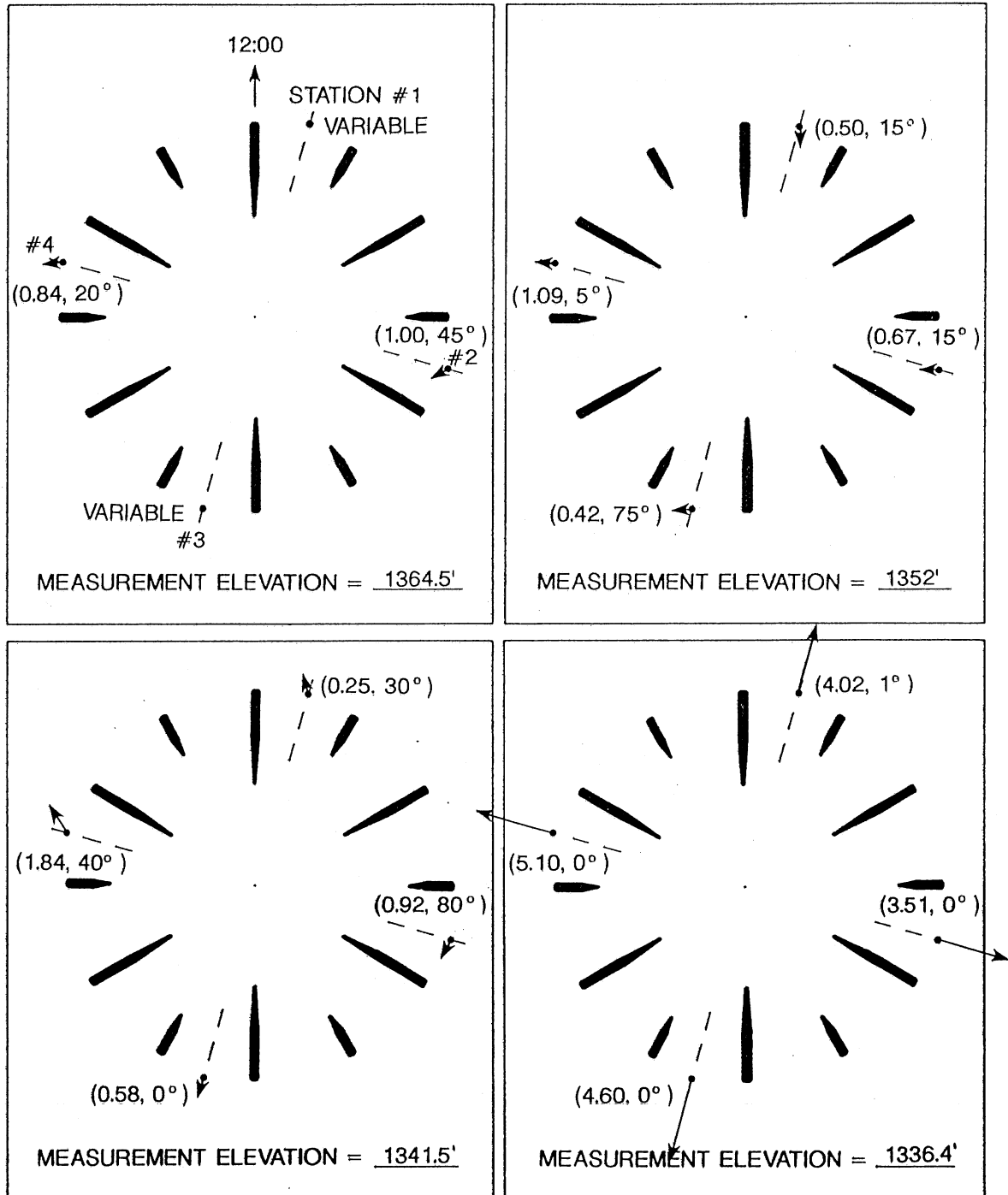

Figure 16. Outlet Velocity Measurements Pump Mode, Reservoir Elev. 1366, Q = 15,000 cfs.

# VELOCITY MEASUREMENTS AT STRUCTURE

OPERATING MODE PUMP

WATER SURFACE ELEVATION 1366'

FLOW RATE 15,000 CFS

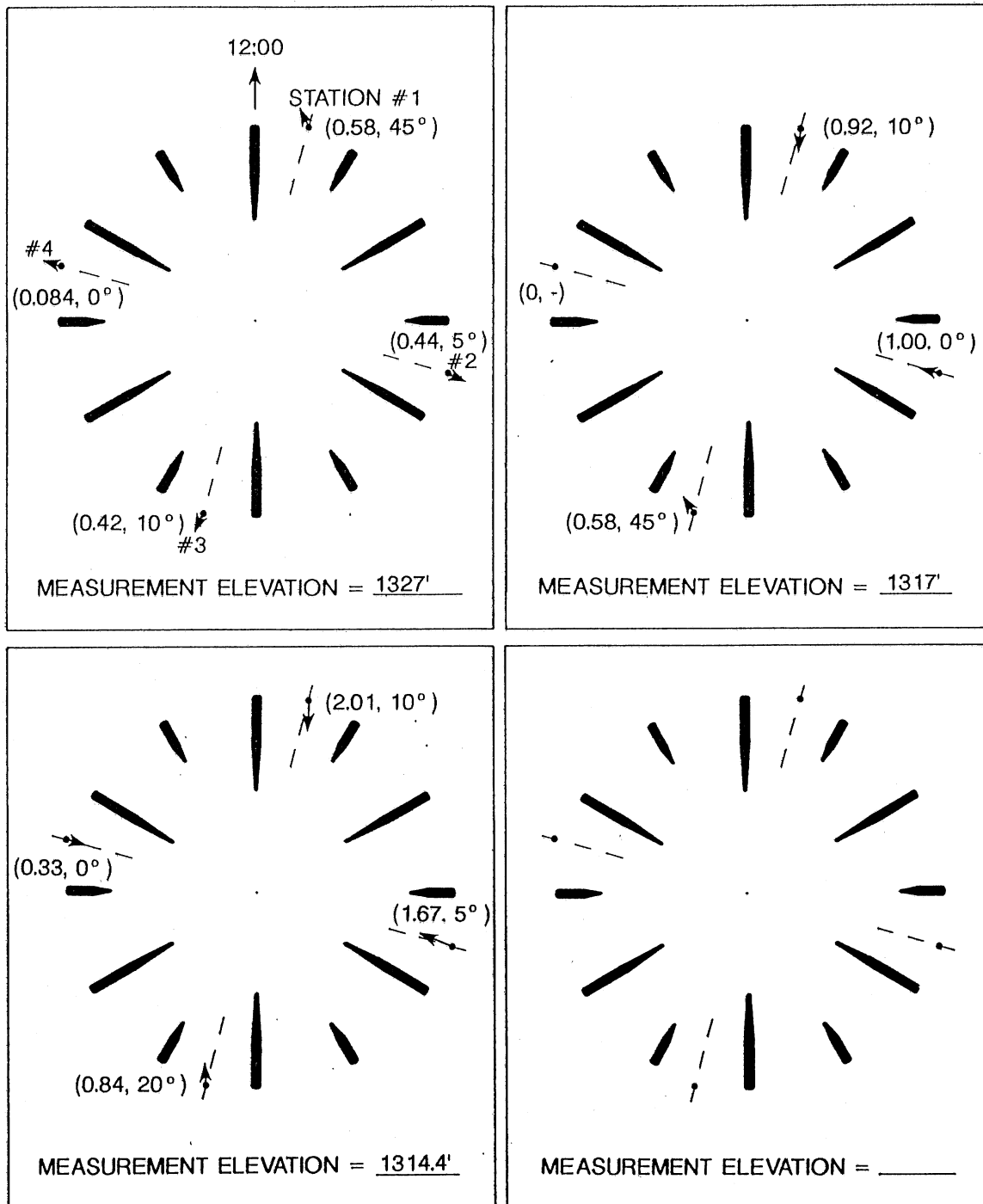

Figure 17. Outlet Velocity Measurements Pump Mode, Reservoir Elev. 1366, Q = 15,000 cfs.

VELOCITY MEASUREMENTS AT STRUCTURE

OPERATING MODE PUMP

WATER SURFACE ELEVATION 1341'

FLOW RATE 15,000 CFS

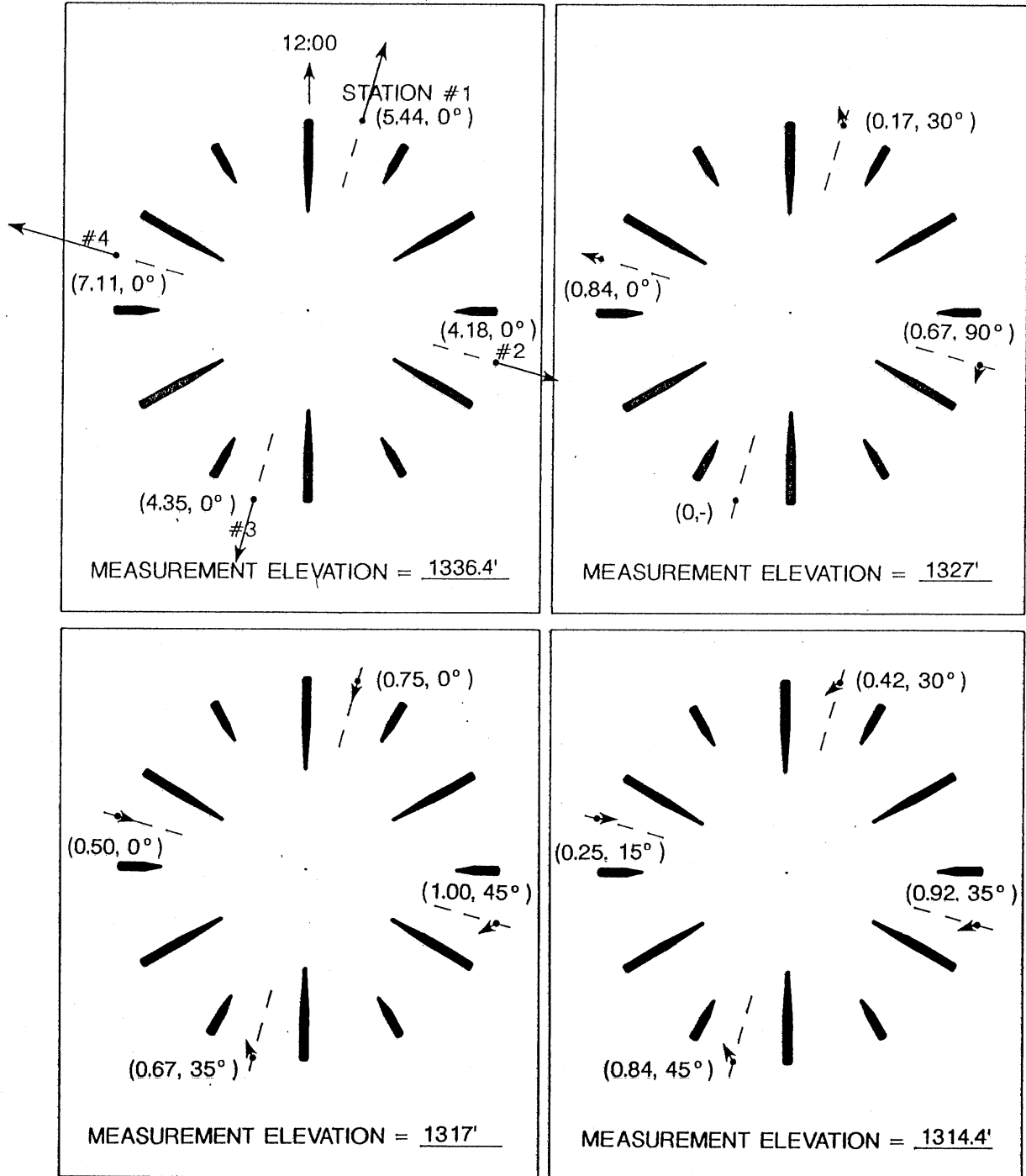

Figure 18. Outlet Velocity Measurements Pump Mode, Reservoir Elev. 1341, Q = 15,000 cfs.

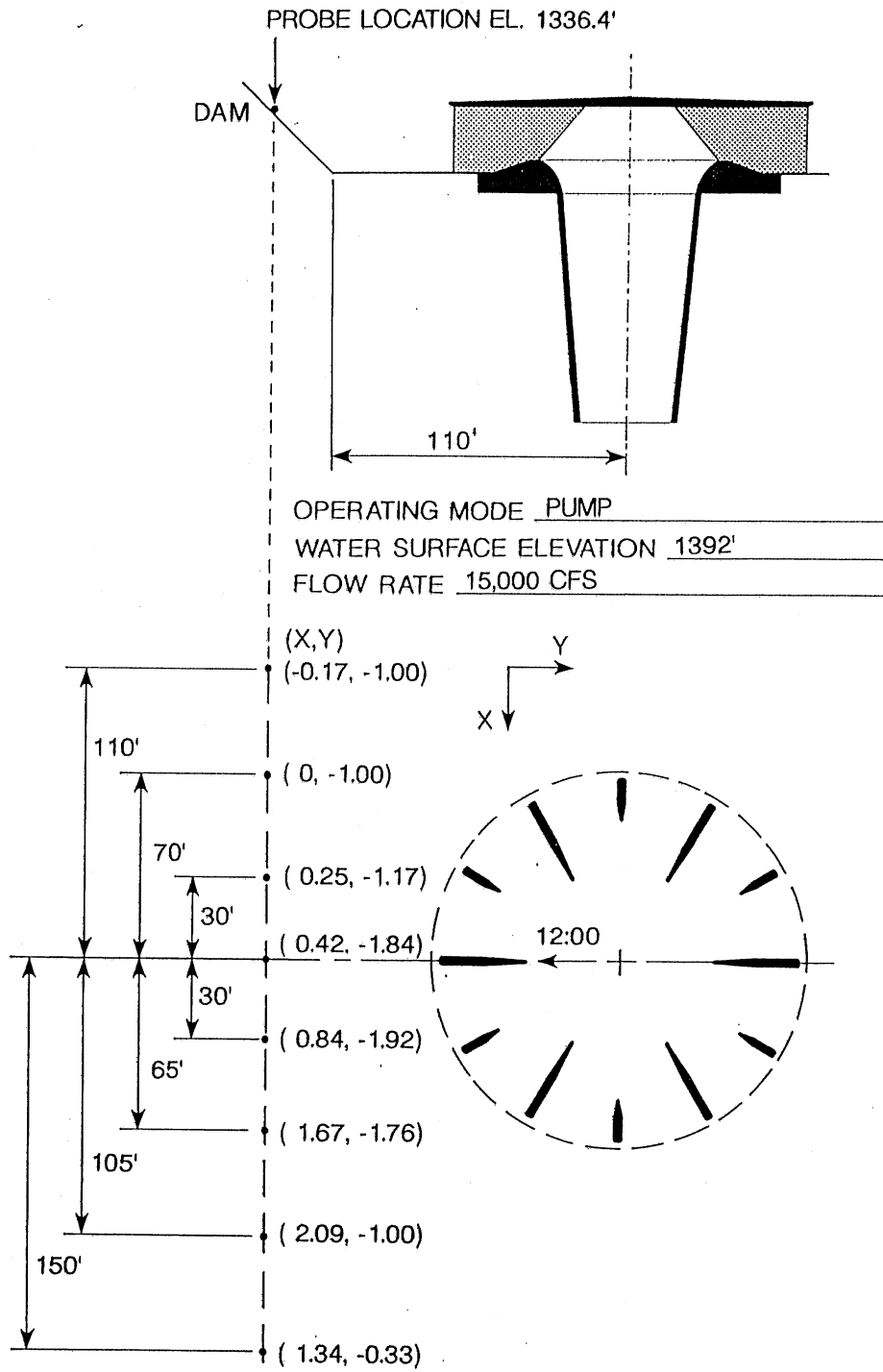

Figure 19. Velocity Measurements Near Dam-Pump Mode, Reservoir Elev. 1392,  $Q = 15,000$  cfs.



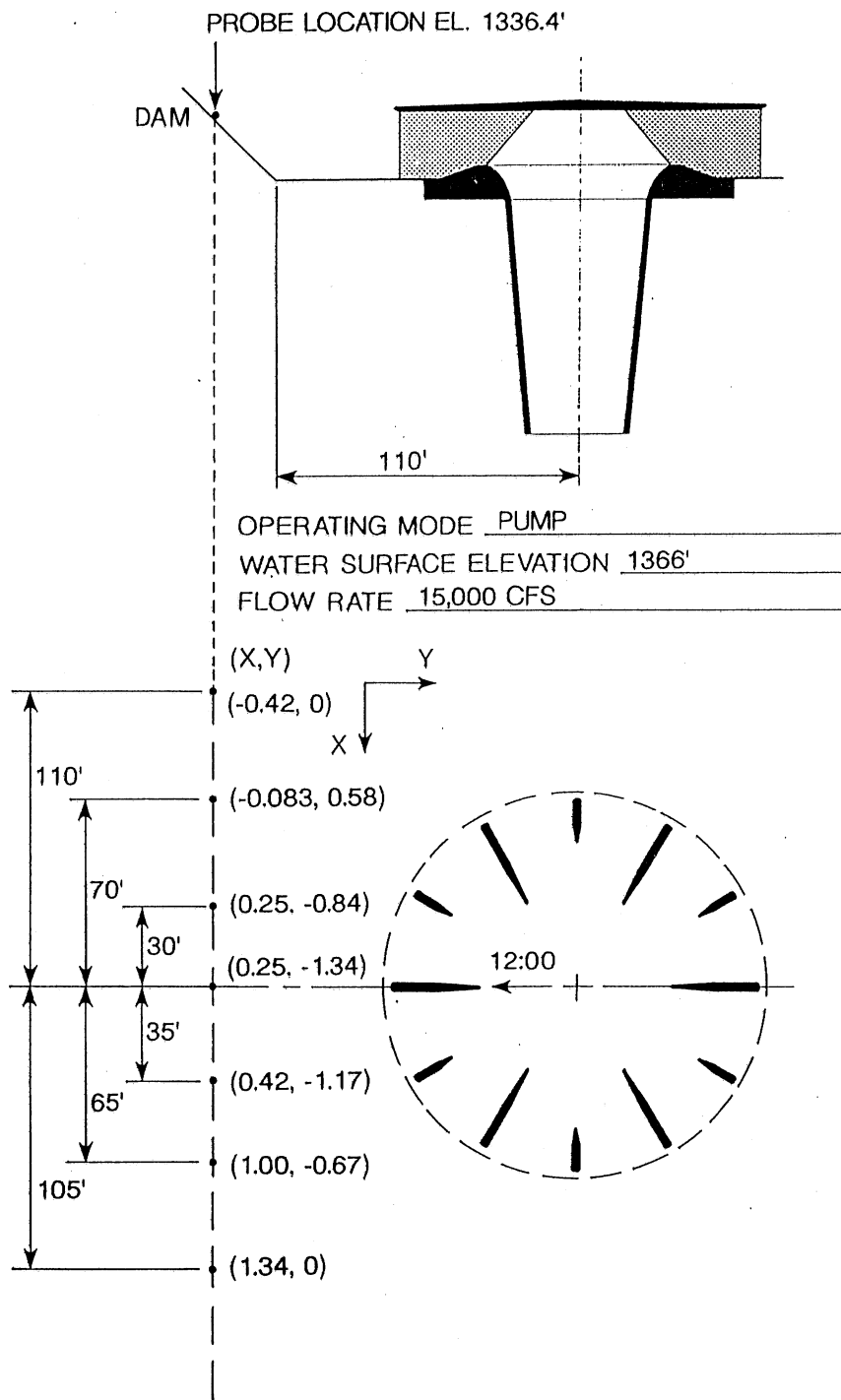

Figure 20. Velocity Measurements Near Dam-Pump Mode, Reservoir Elev. 1366,  $Q = 15,000$  cfs.

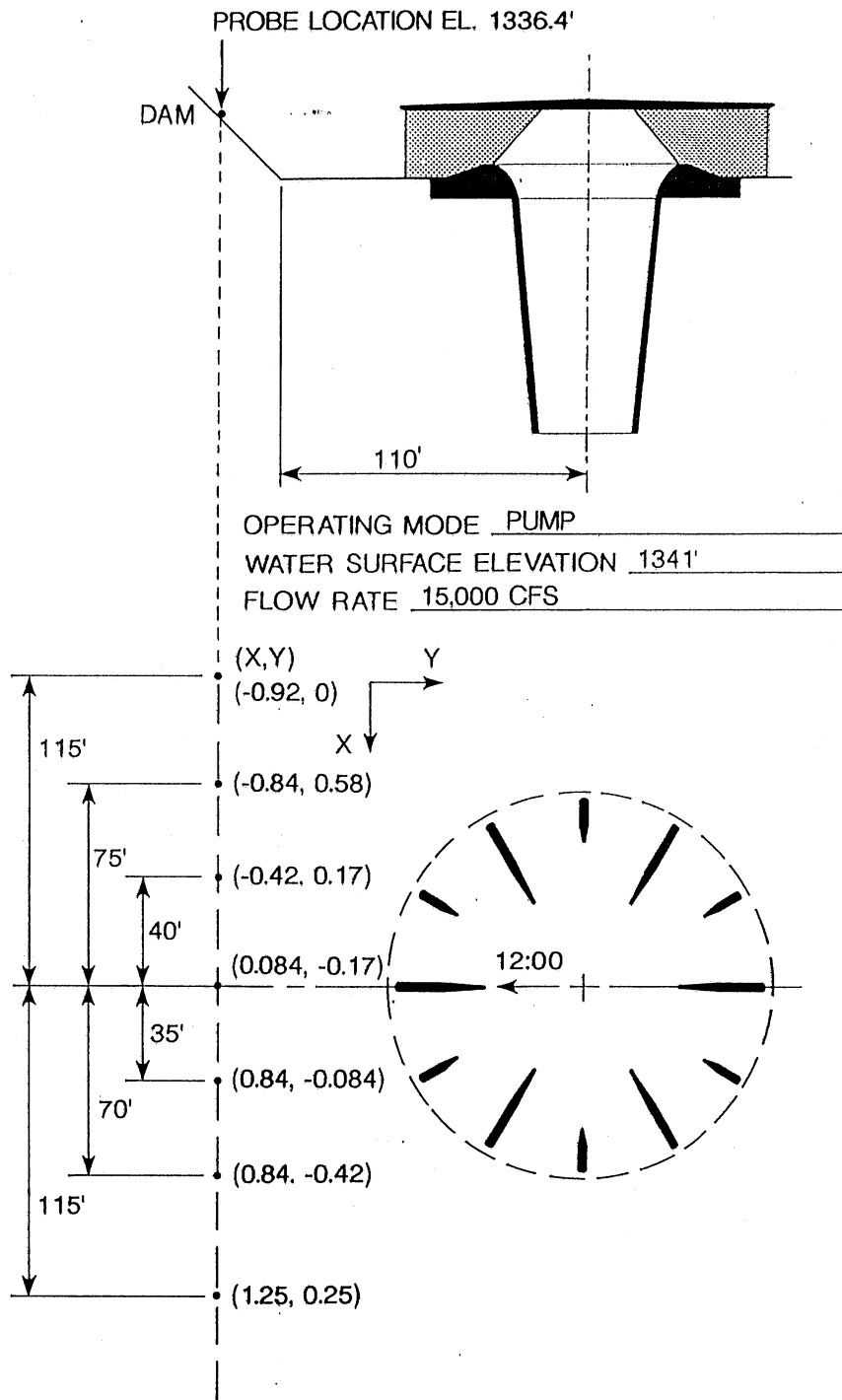
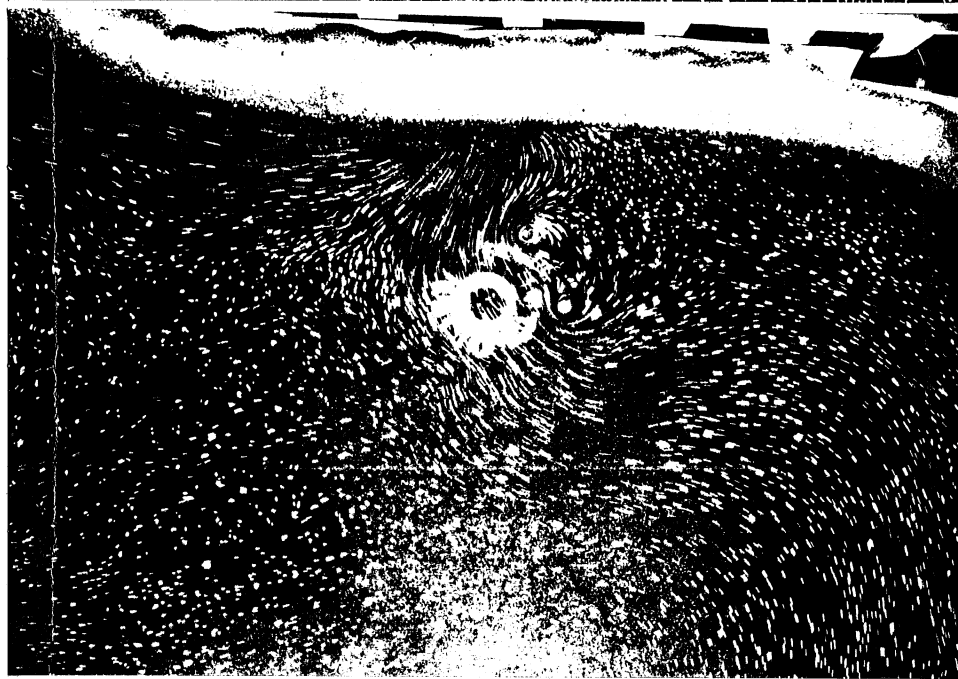
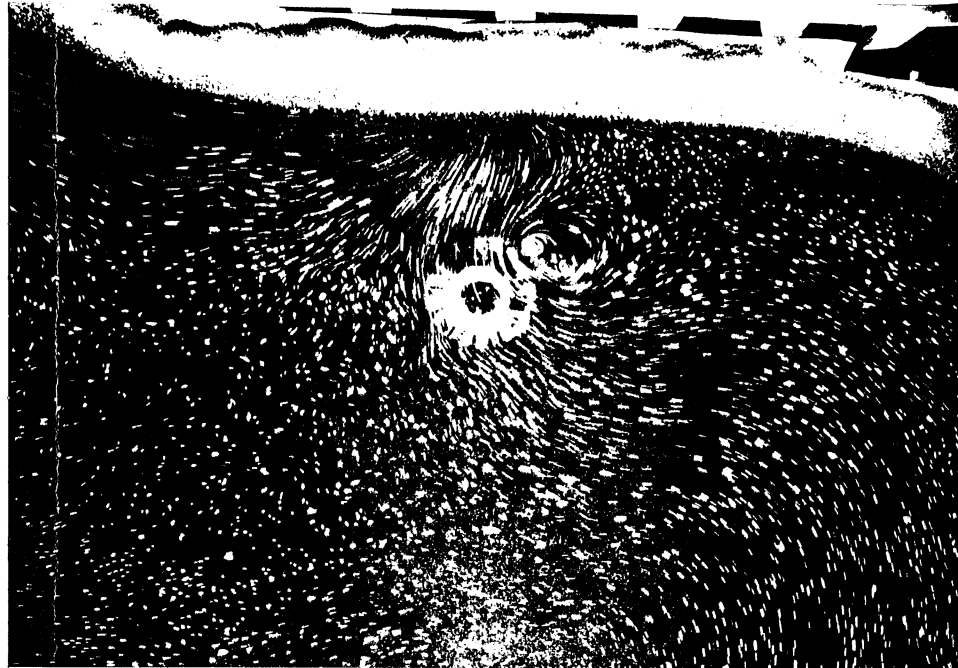
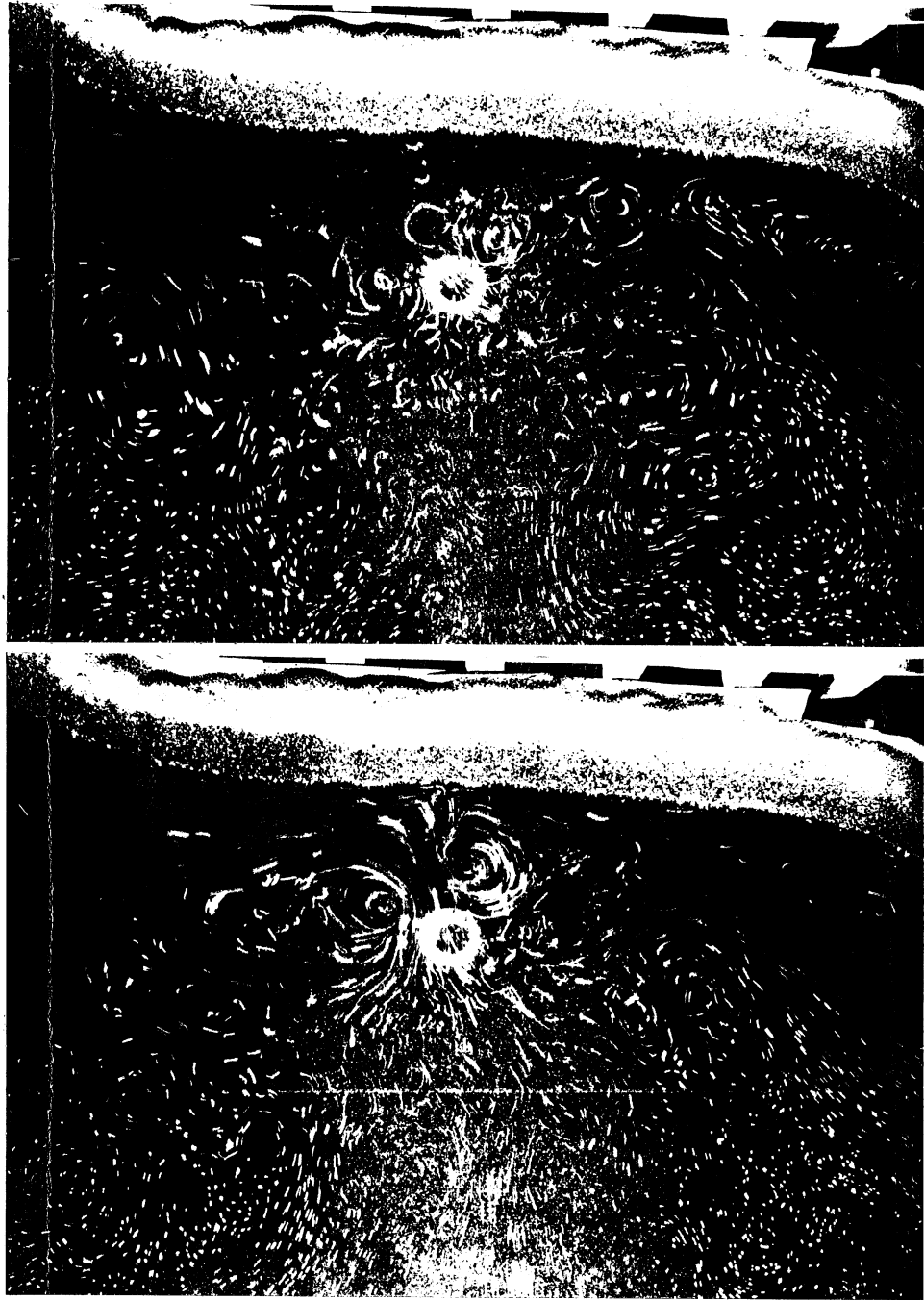

Figure 21. Velocity Measurements Near Dam-Pump Mode, Reservoir Elev. 1341,  $Q = 15,000$  cfs.



Photos 1 & 2 Surface Flow Patterns - Exposure Time - 8 secs,  
Turbine Mode, WS Elev 1366,  $Q = 18,000$  cfs.



Photos 3 & 4 Surface Flow Patterns - Exposure Time - 8 secs,  
Pump Mode, WS Elev 1366,  $Q = 15,000$  cfs.